



US00D405390S

United States Patent [19]
Castiglione et al.

[11] **Patent Number: Des. 405,390**

[45] **Date of Patent: **Feb. 9, 1999**

[54] **AUTOMOBILE BODY**

D. 385,222 10/1997 Hill et al. D12/92

[75] Inventors: **Micheal R. Castiglione; Kevin R. Verduyn**, both of Carlsbad; **Thomas G. Tremont**, San Diego, all of Calif.; **K. Neil Walling**, Leonard, Mich.

OTHER PUBLICATIONS

The Porsche Book, a definitive illustrated history, Luthar Boschen and Jürgen Barth, 1977, pp. 329, 332.

[73] Assignee: **Chrysler Corporation**, Auburn Hills, Mich.

Primary Examiner—Melody N. Brown
Attorney, Agent, or Firm—Mark P. Calcaterra

[**] Term: **14 Years**

[57] **CLAIM**

The ornamental design for an automobile body, as shown and described.

[21] Appl. No.: **78,602**

DESCRIPTION

[22] Filed: **Oct. 29, 1997**

FIG. 1 is a front perspective view illustrating an automobile body constructed in accordance with the teachings of the present invention;

[51] **LOC (6) Cl. 12-08**

[52] **U.S. Cl. D12/92**

[58] **Field of Search D12/90-92; 296/185**

FIG. 2 is a rear perspective view thereof;

FIG. 3 is a left side view, it will be understood that the side opposite to that shown is a substantial mirror image thereof;

FIG. 4 is a front view thereof; and,

FIG. 5 is a rear view thereof.

It will be understood that the broken line showing of the wheels and tires throughout the drawings is for illustrative purposes only and forms no part of the subject invention.

[56] **References Cited**

U.S. PATENT DOCUMENTS

- D. 353,563 12/1994 Ferrerio et al. D12/91
- D. 354,459 1/1995 Honarkhah et al. D12/92
- D. 360,171 7/1995 Hubbach et al. D12/91
- D. 361,046 8/1995 Watkins et al. D12/92
- D. 378,203 2/1997 Huang D12/92

1 Claim, 4 Drawing Sheets

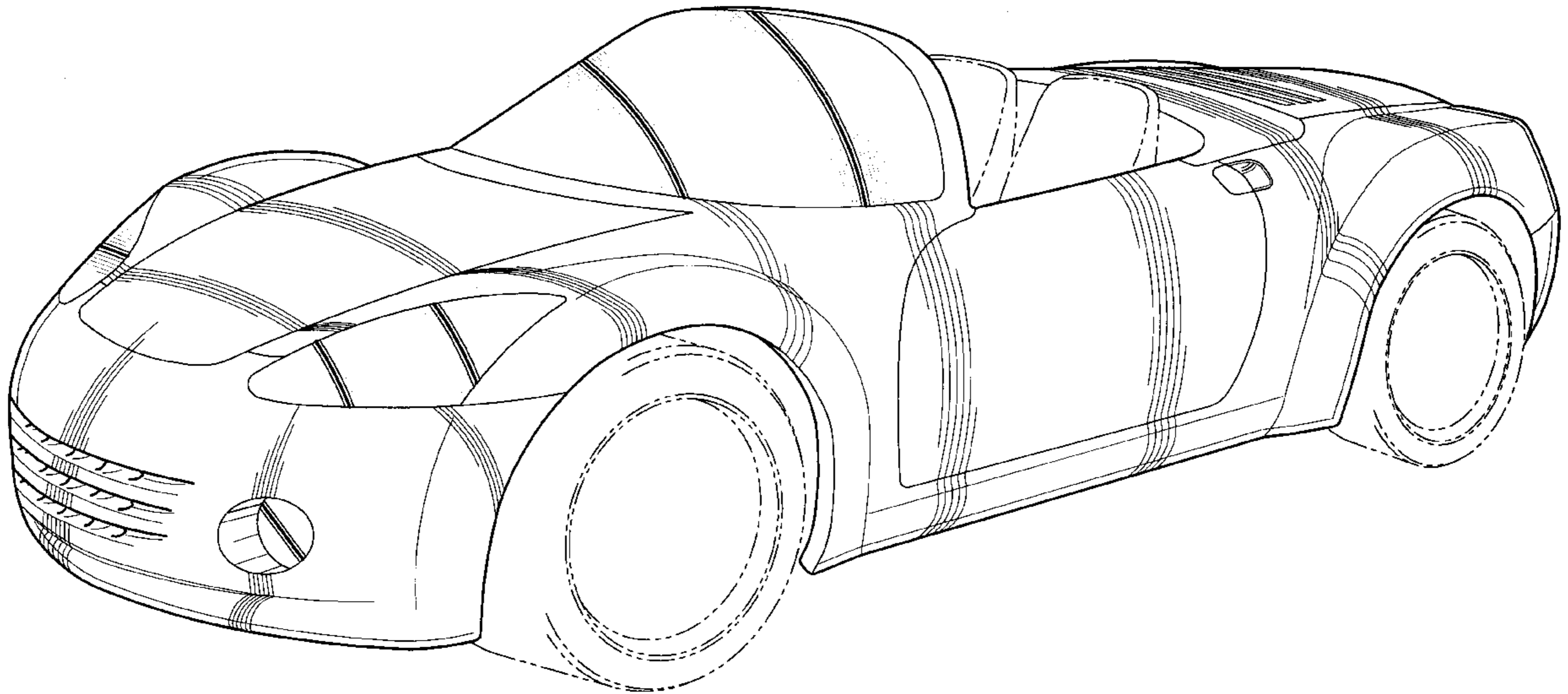

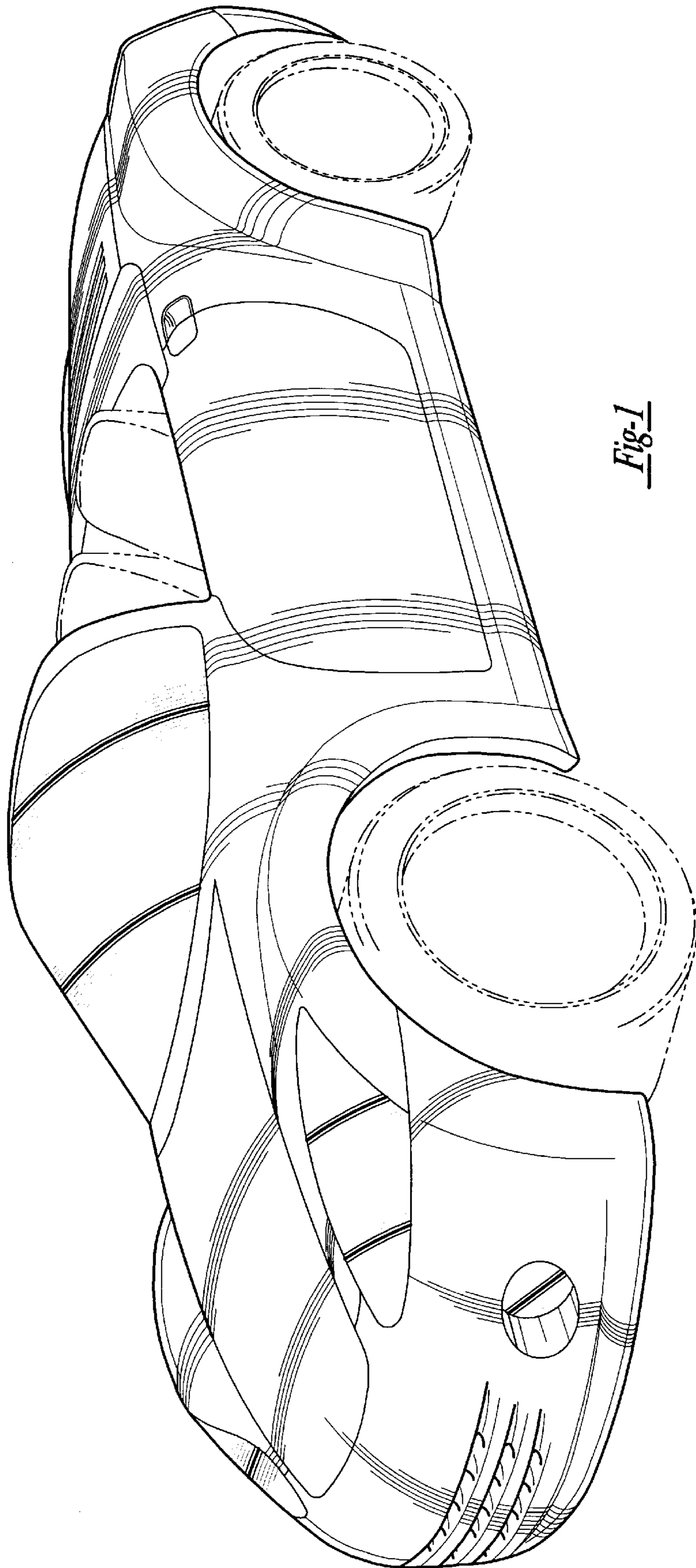

Fig-1

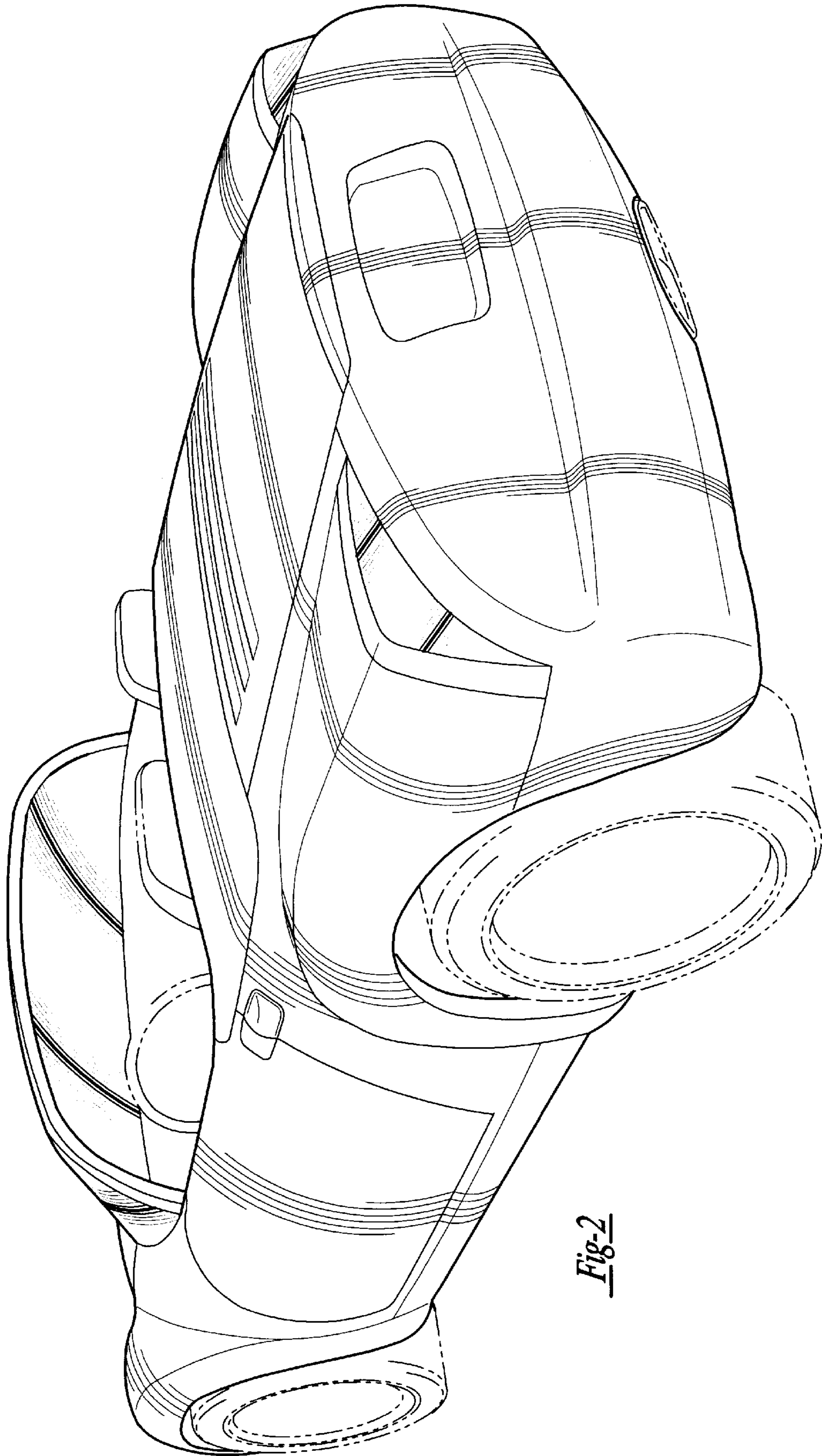

Fig-2

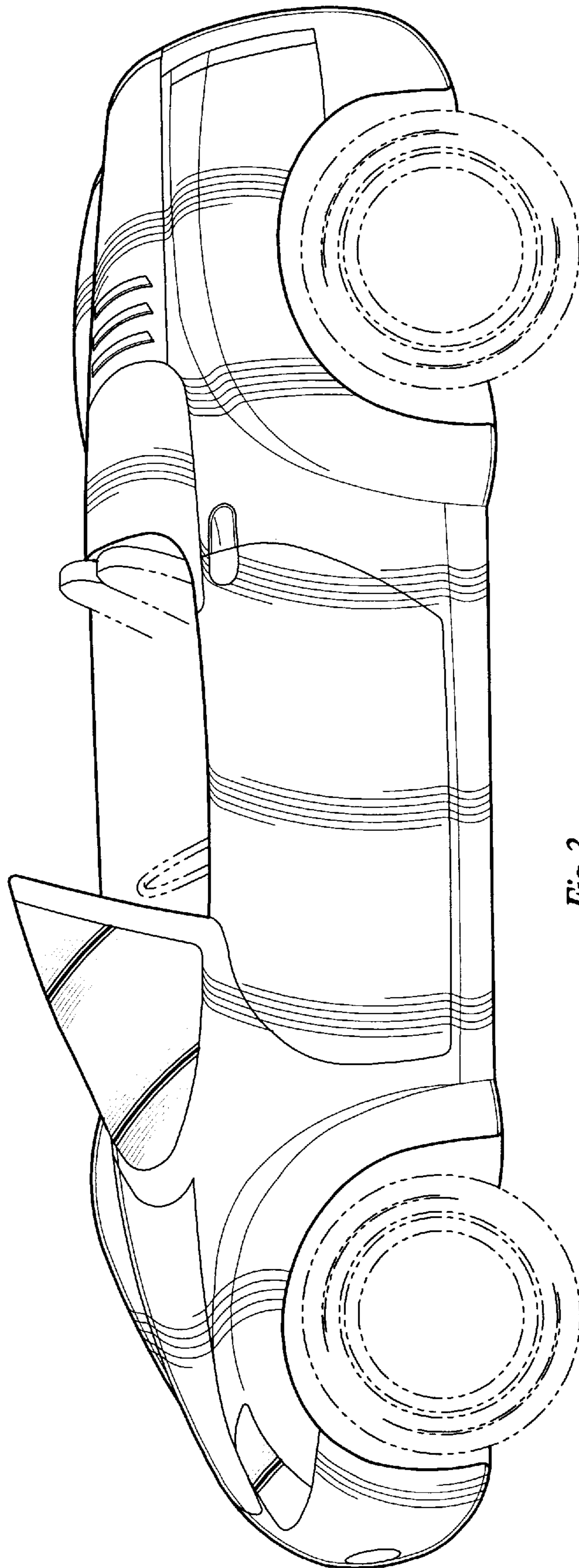

Fig-3

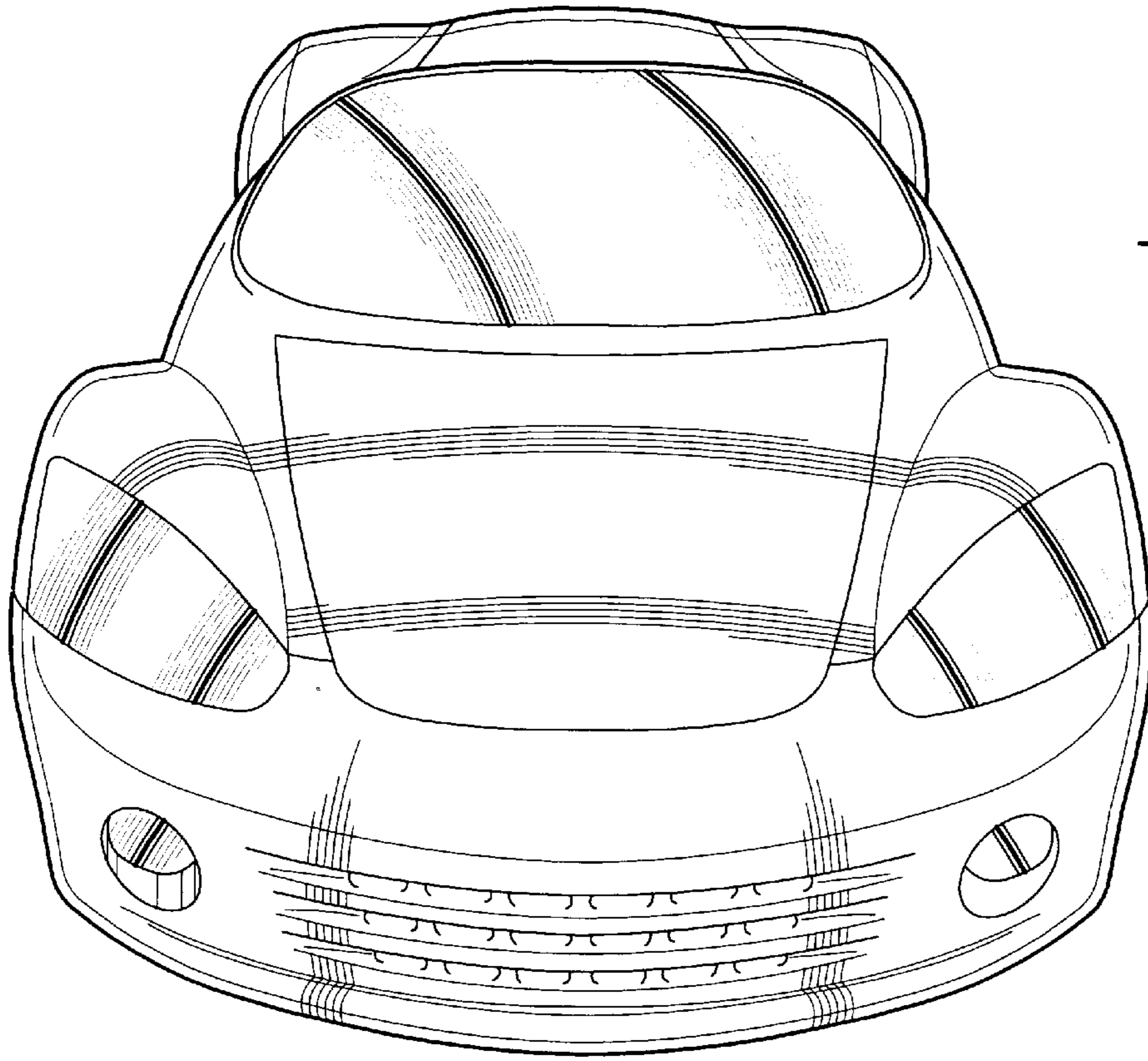

Fig-4

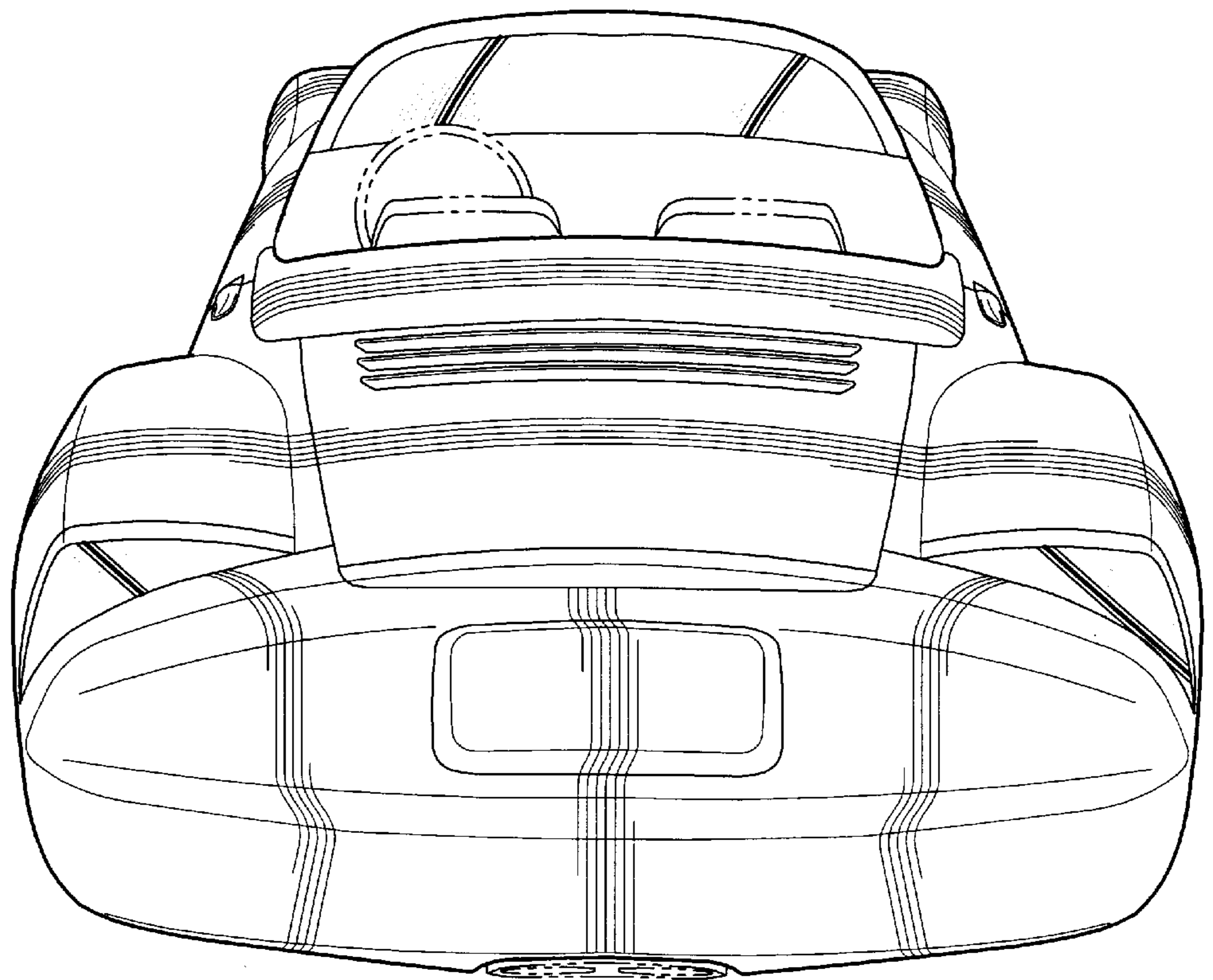

Fig-5