



US00D405095S

United States Patent [19]

Wada

[11] Patent Number: **Des. 405,095**

[45] Date of Patent: ****Feb. 2, 1999**

[54] **AIR INTAKE MANIFOLD FOR INTERNAL COMBUSTION ENGINES**

[75] Inventor: **Tetsu Wada, Wako, Japan**

[73] Assignee: **Honda Giken Kogyo Kabushiki Kaisha, Tokyo, Japan**

[**] Term: **14 Years**

[21] Appl. No.: **73,048**

[22] Filed: **Jun. 18, 1997**

[30] **Foreign Application Priority Data**

Dec. 19, 1996	[JP]	Japan	8-38515
Jan. 31, 1997	[JP]	Japan	9-2706
Jun. 13, 1997	[JP]	Japan	9-57932
Jun. 13, 1997	[JP]	Japan	9-57933

[51] **LOC (6) Cl.** **15-01**

[52] **U.S. Cl.** **D15/5**

[58] **Field of Search** D12/194; D15/1-5; 60/299, 302, 313, 323, 324; 123/184.35, 184.55, 184.61, 572

[56] **References Cited**

U.S. PATENT DOCUMENTS

D. 368,247	3/1996	Jones	D12/194
5,209,191	5/1993	Kopec	123/184.61 X
5,572,868	11/1996	Okamoto et al.	60/323
5,638,785	6/1997	Lee	123/184.35

Primary Examiner—Philip S. Hyder
Assistant Examiner—Nanda Bondade
Attorney, Agent, or Firm—Lyon & Lyon LLP

[57] **CLAIM**

The ornamental design for an air intake manifold for internal combustion engines, as shown.

DESCRIPTION

FIG. 1 is a front elevation view of an air intake manifold for internal combustion engines showing a first embodiment of my new design;

FIG. 2 is a left side elevation view of the first embodiment;

FIG. 3 is a right side elevation view of the first embodiment;

FIG. 4 is a top plan view of the first embodiment;

FIG. 5 is a bottom view of the first embodiment;

FIG. 6 is a rear elevation view of the first embodiment;

FIG. 7 is a front elevation view of an air intake manifold for internal combustion engines showing a second embodiment of my new design;

FIG. 8 is a left side elevation view of the second embodiment;

FIG. 9 is a right side elevation view of the second embodiment;

FIG. 10 is a top plan view of the second embodiment;

FIG. 11 is a bottom view of the second embodiment;

FIG. 12 is a rear elevation view of the second embodiment;

FIG. 13 is a front elevation view of an air intake manifold for internal combustion engines showing a third embodiment of my new design;

FIG. 14 is a left side elevation view of the third embodiment;

FIG. 15 is a right side elevation view of the third embodiment;

FIG. 16 is a top plan view of the third embodiment;

FIG. 17 is a bottom view of the third embodiment;

FIG. 18 is a rear elevation view of the third embodiment;

FIG. 19 is a front elevation view of an air intake manifold for internal combustion engines showing a fourth embodiment of my new design;

FIG. 20 is a left side elevation view of the fourth embodiment;

FIG. 21 is a right side elevation view of the fourth embodiment;

FIG. 22 is a top plan view of the fourth embodiment;

FIG. 23 is a bottom view of the fourth embodiment; and,

FIG. 24 is a rear elevation view of the fourth embodiment.

1 Claim, 12 Drawing Sheets

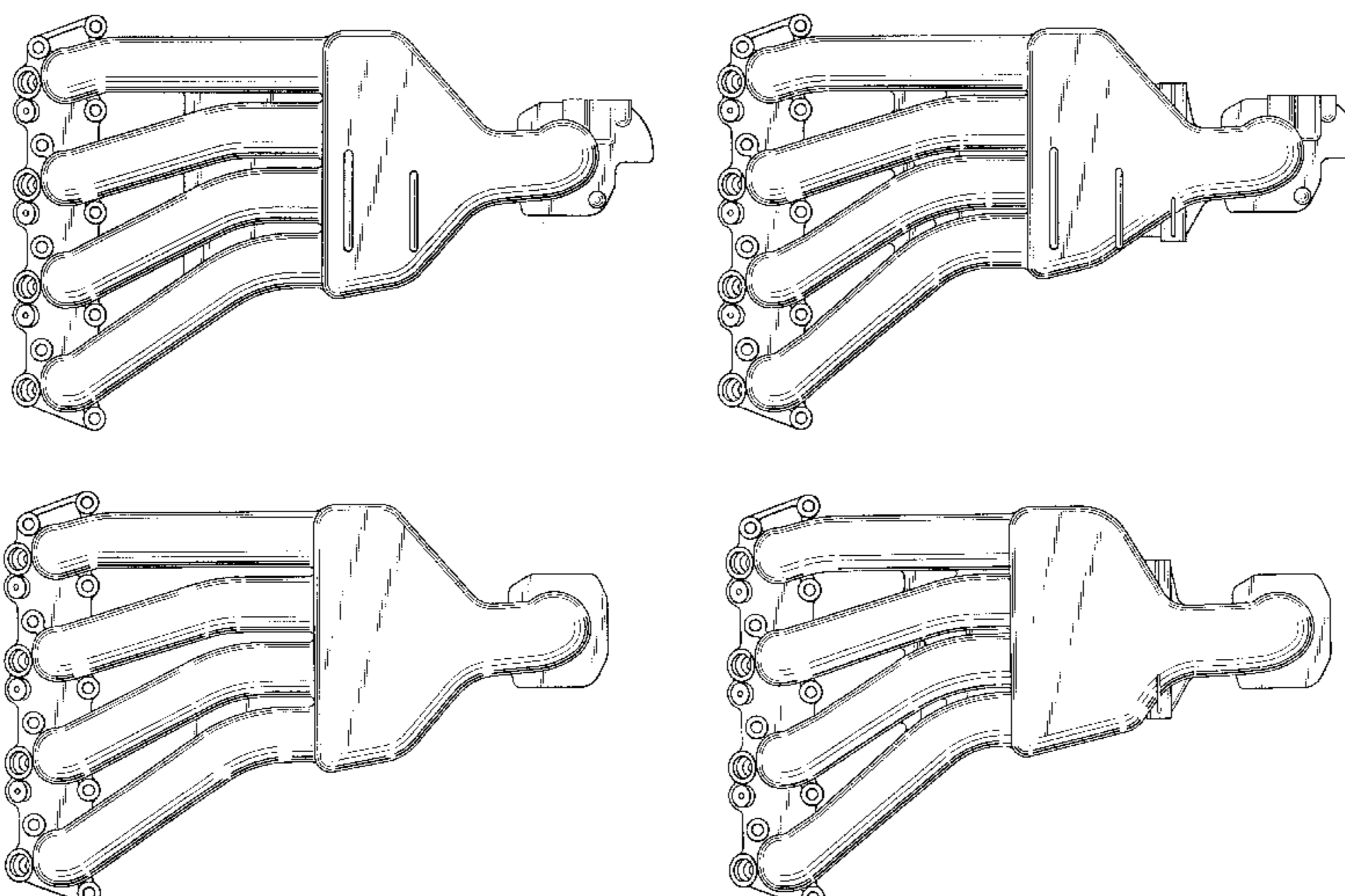

FIG. 3

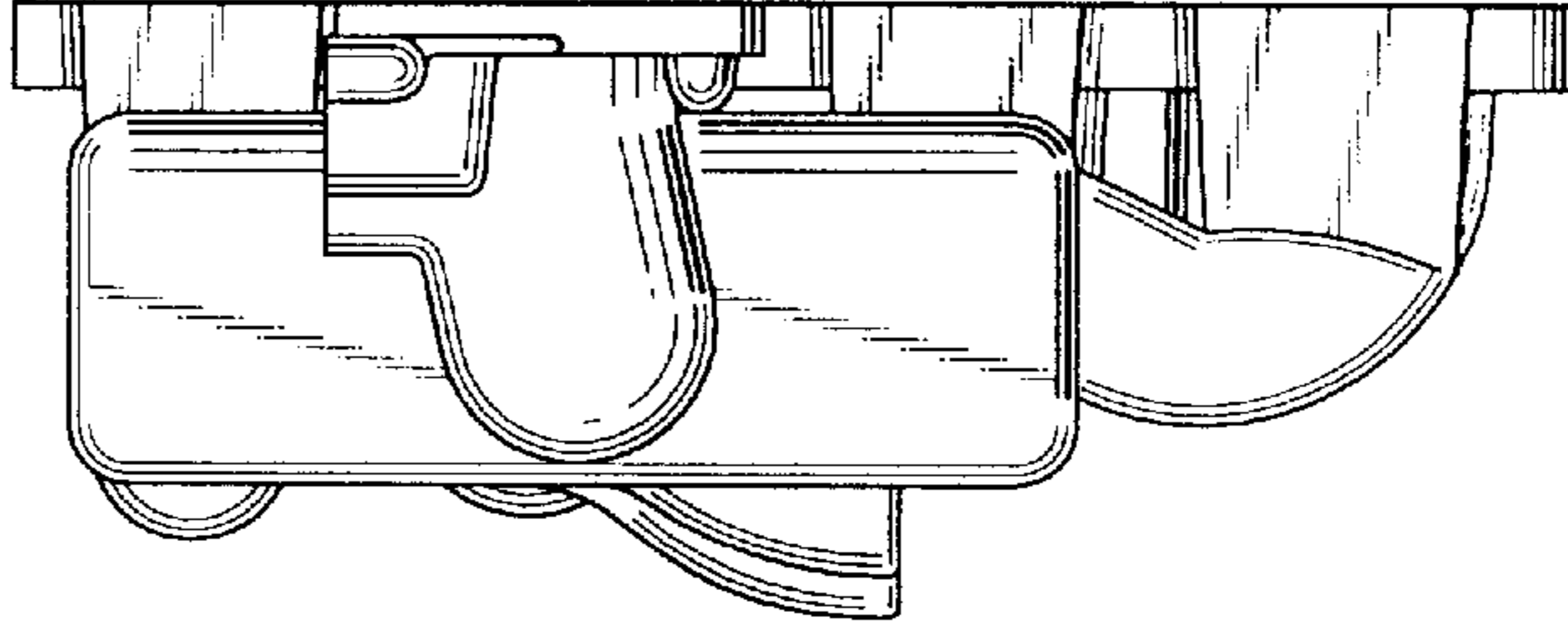

FIG. 1

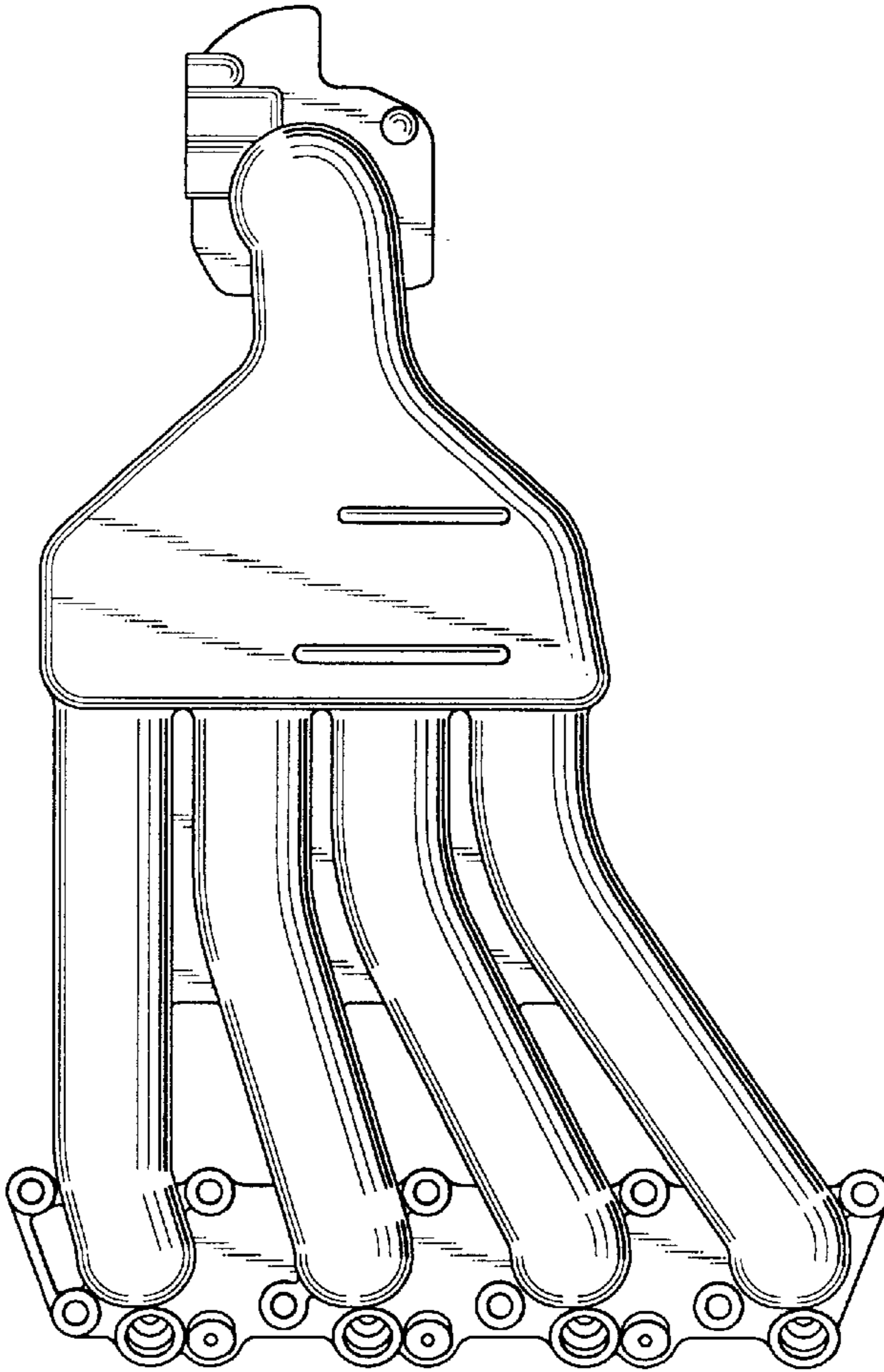

FIG. 2

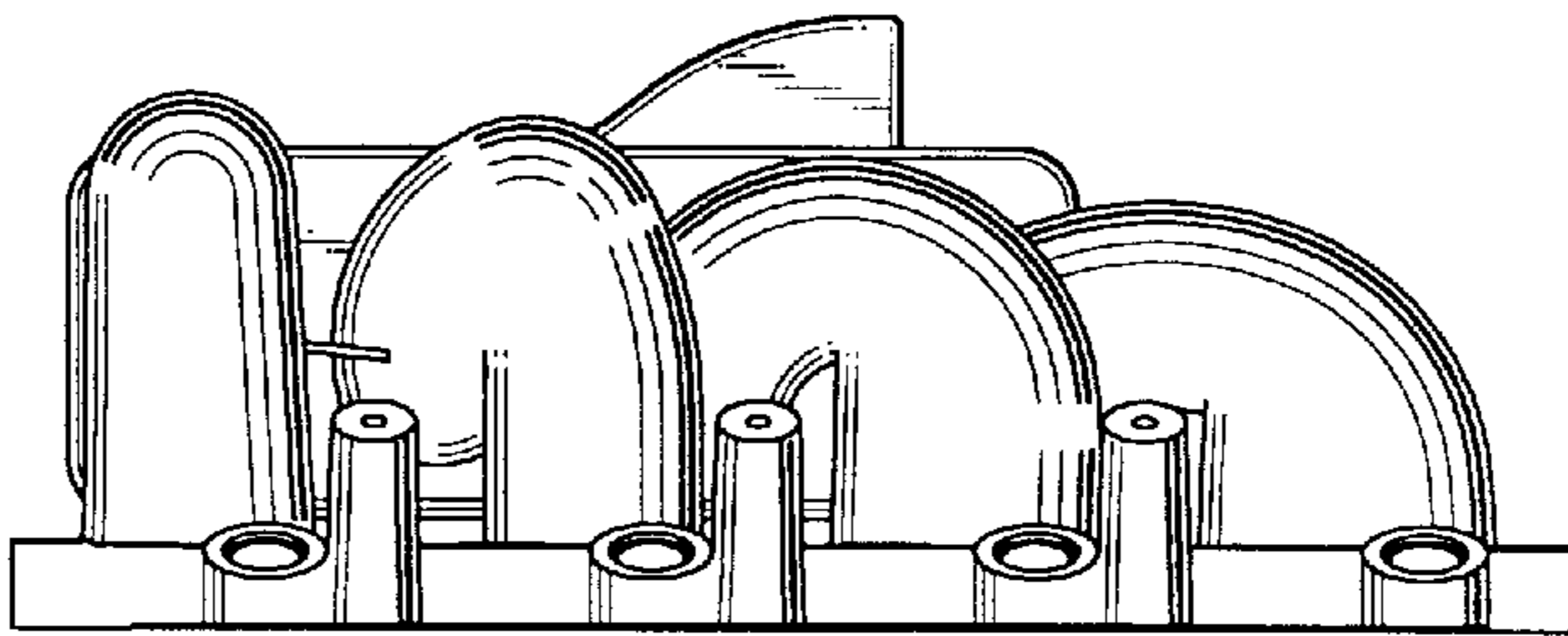

FIG. 4

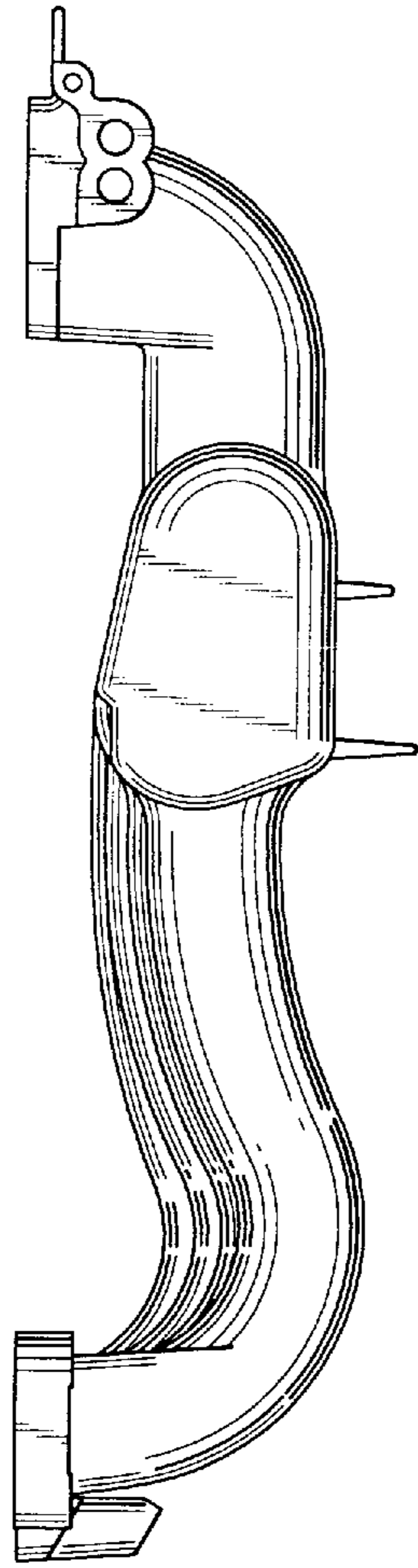

FIG. 5

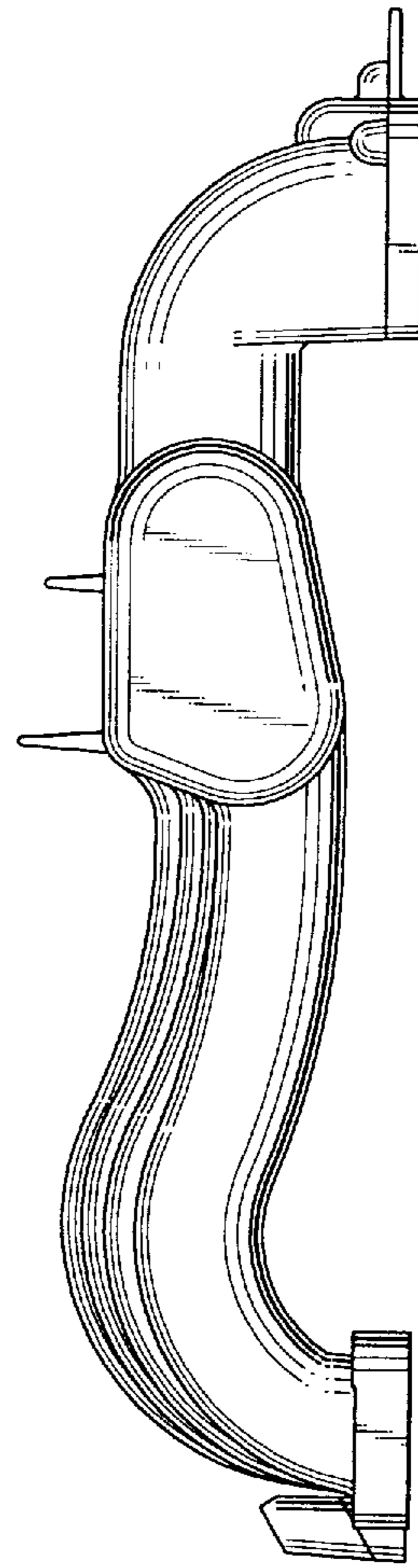

FIG. 6

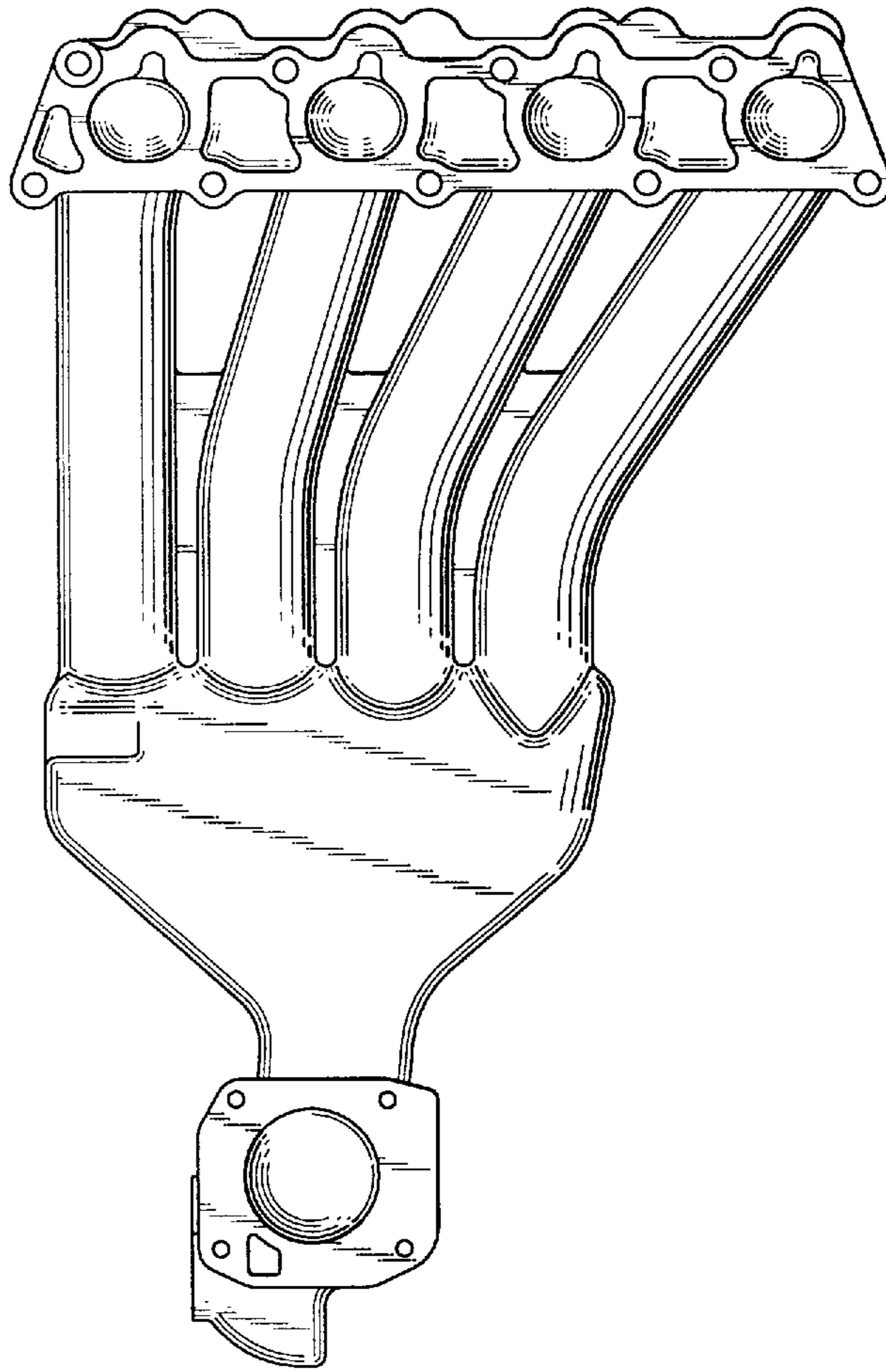

FIG. 9

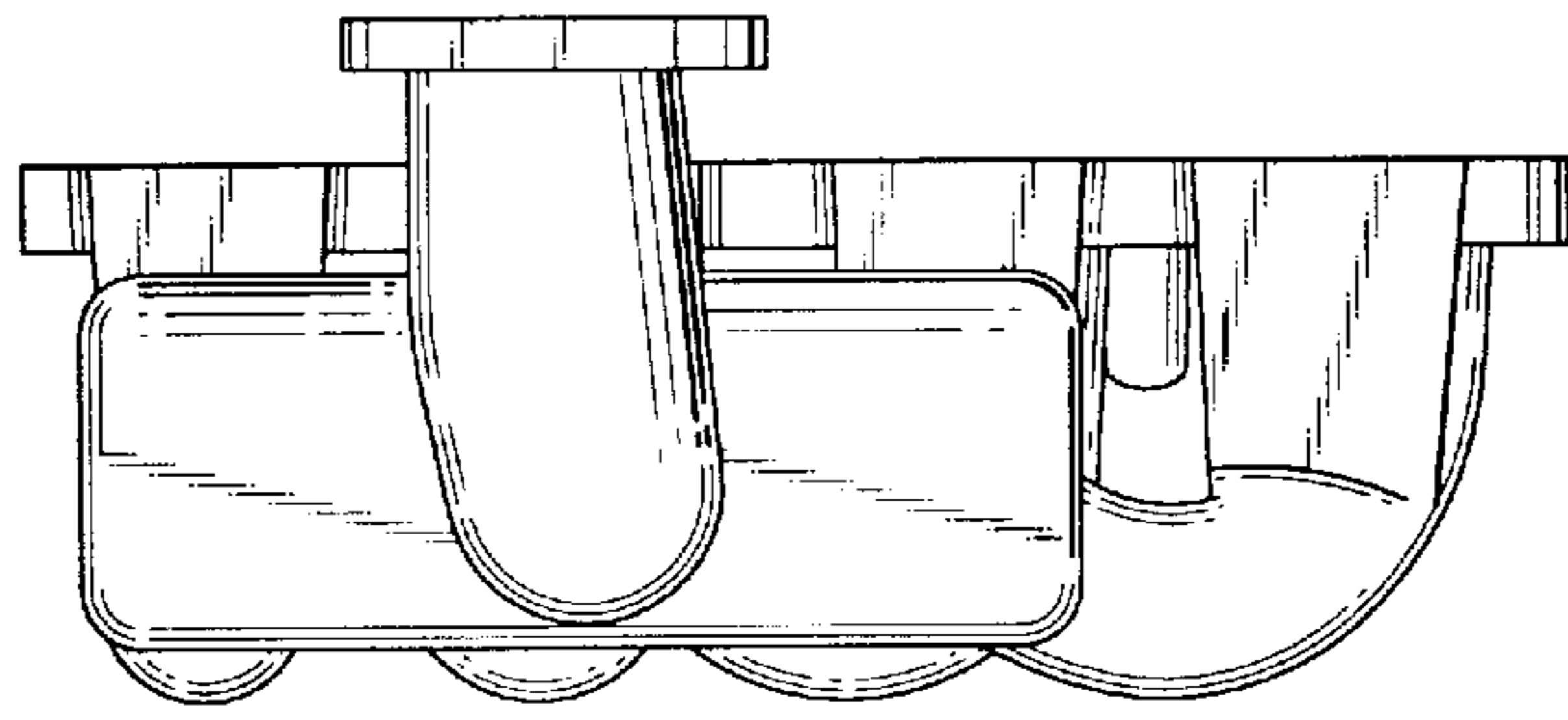

FIG. 7

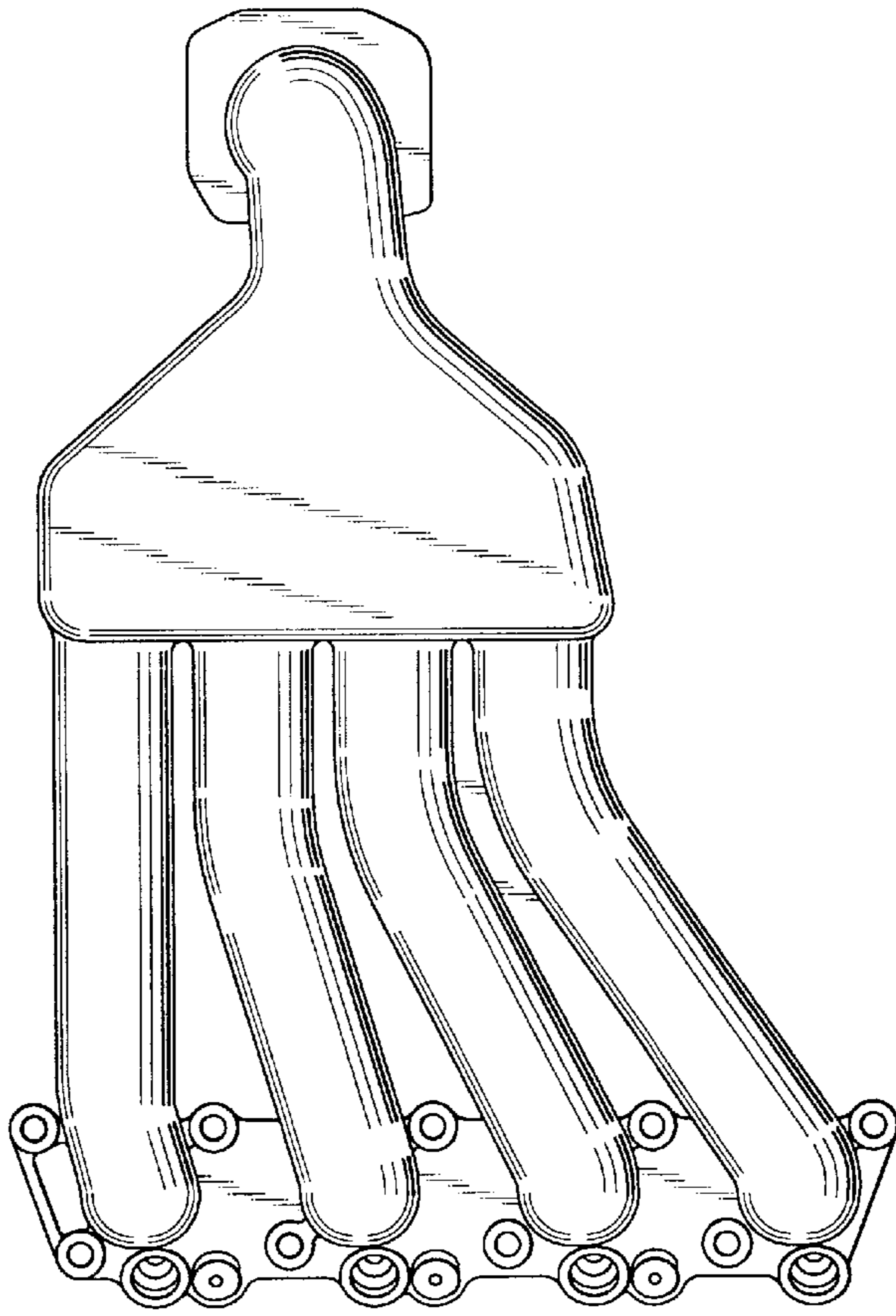

FIG. 8

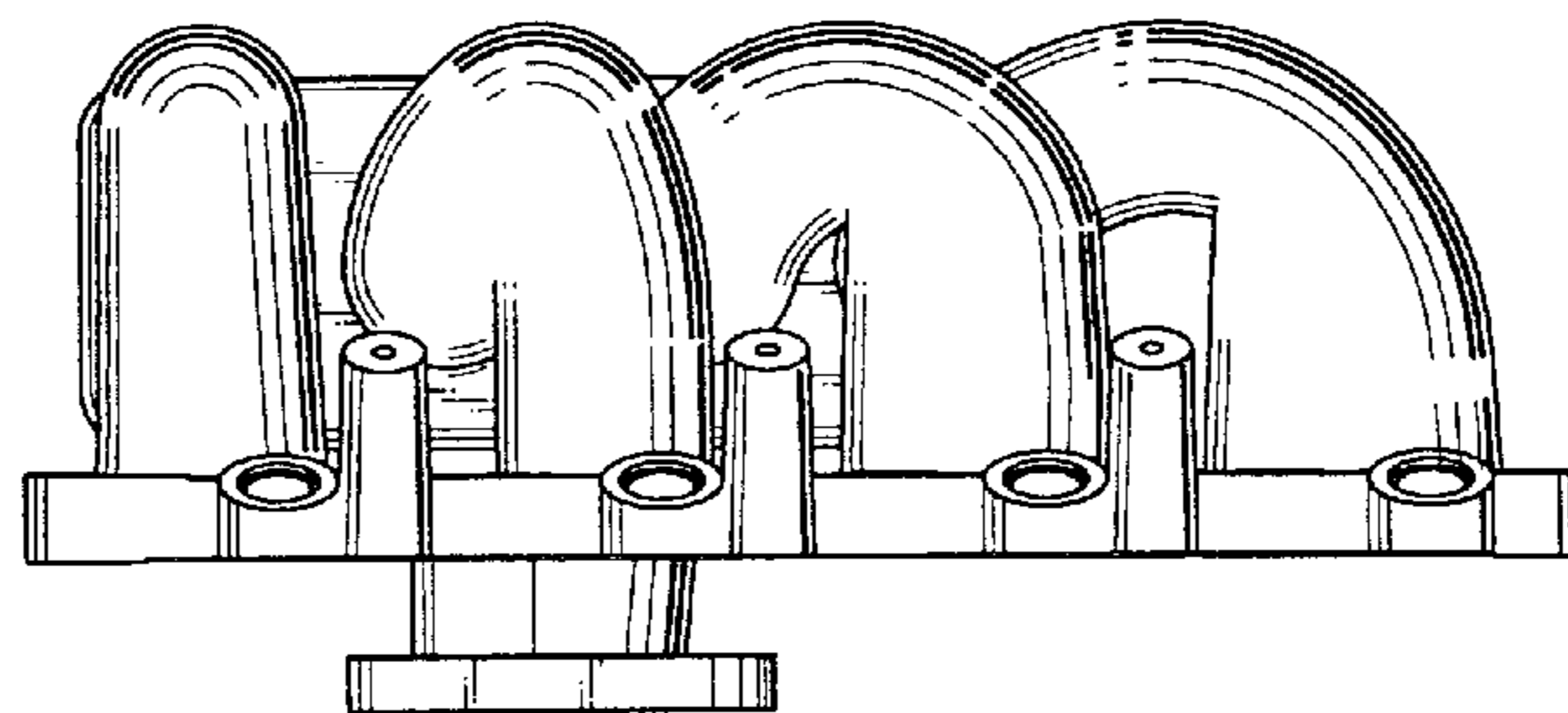

FIG. 10

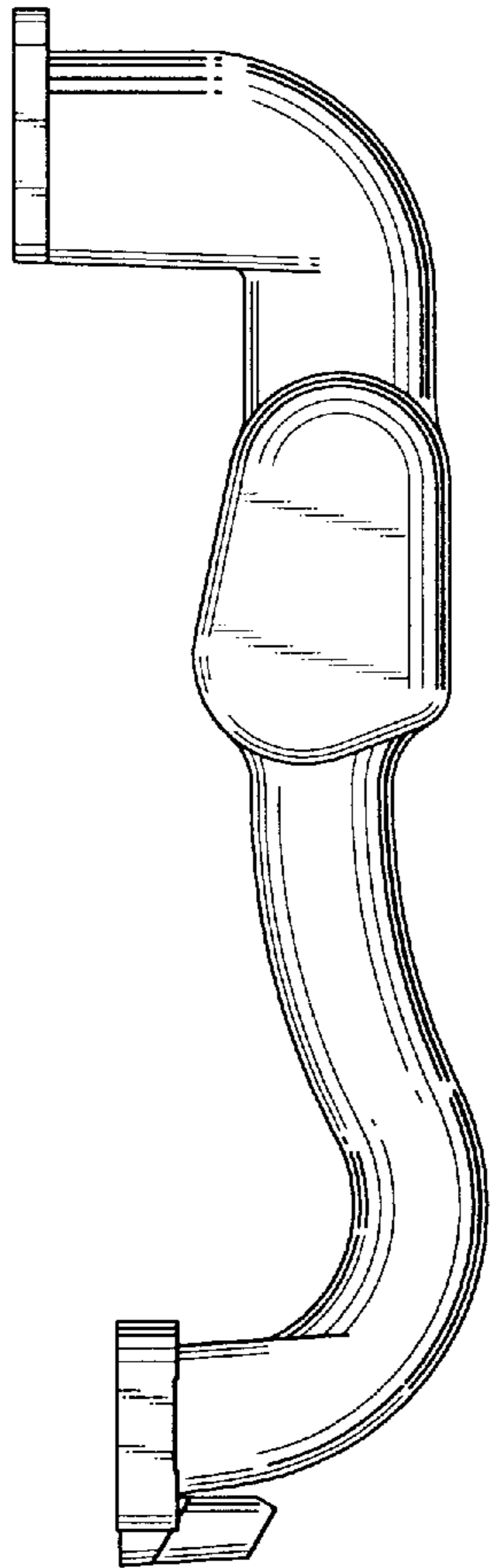

FIG. 11

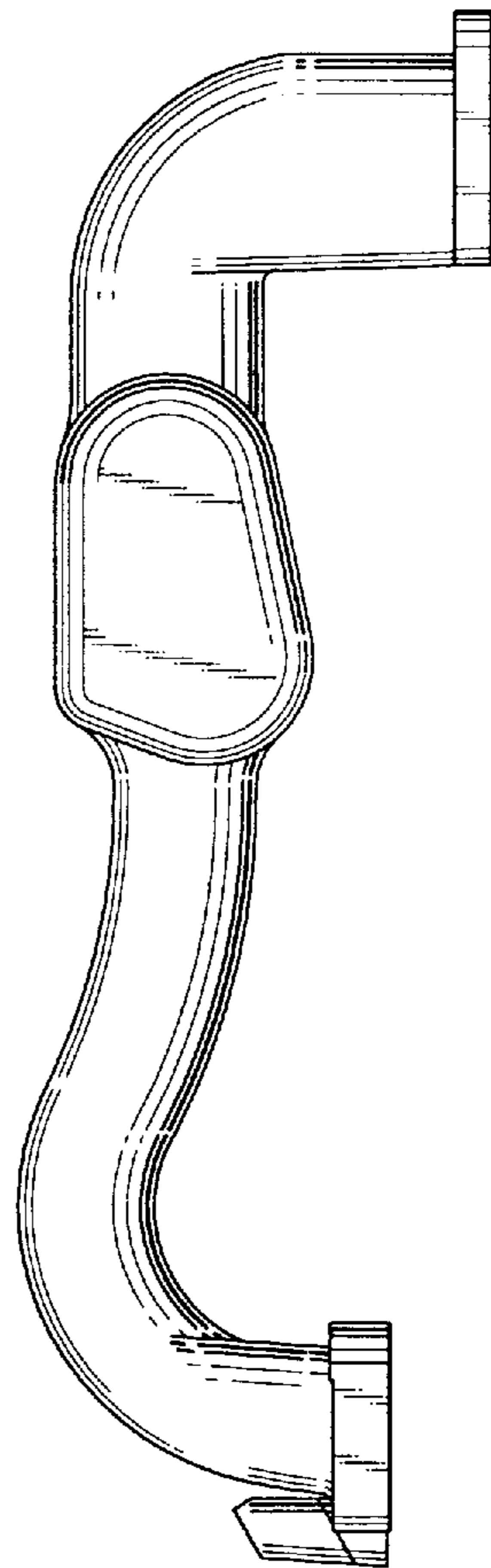

FIG. 12

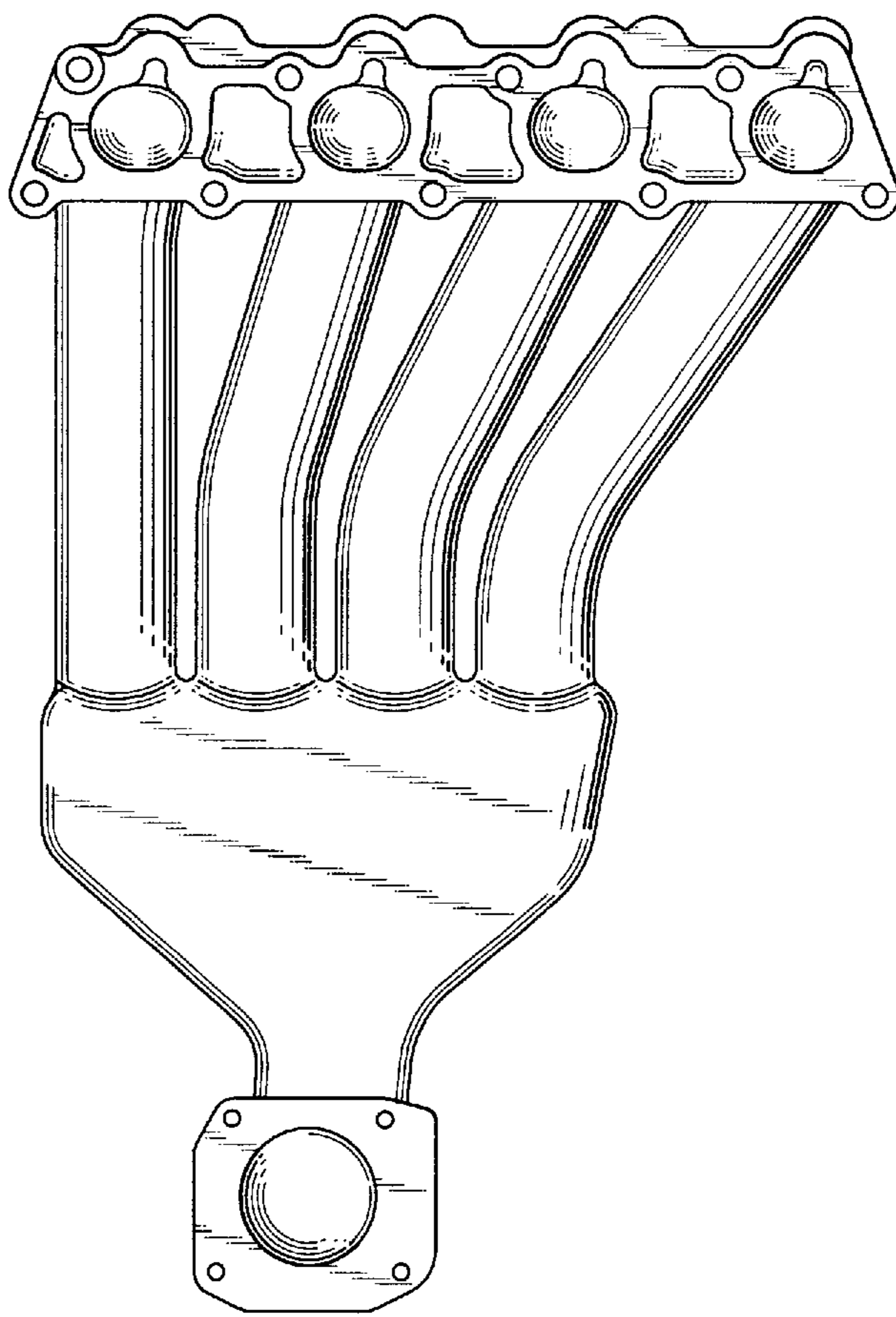

FIG. 15

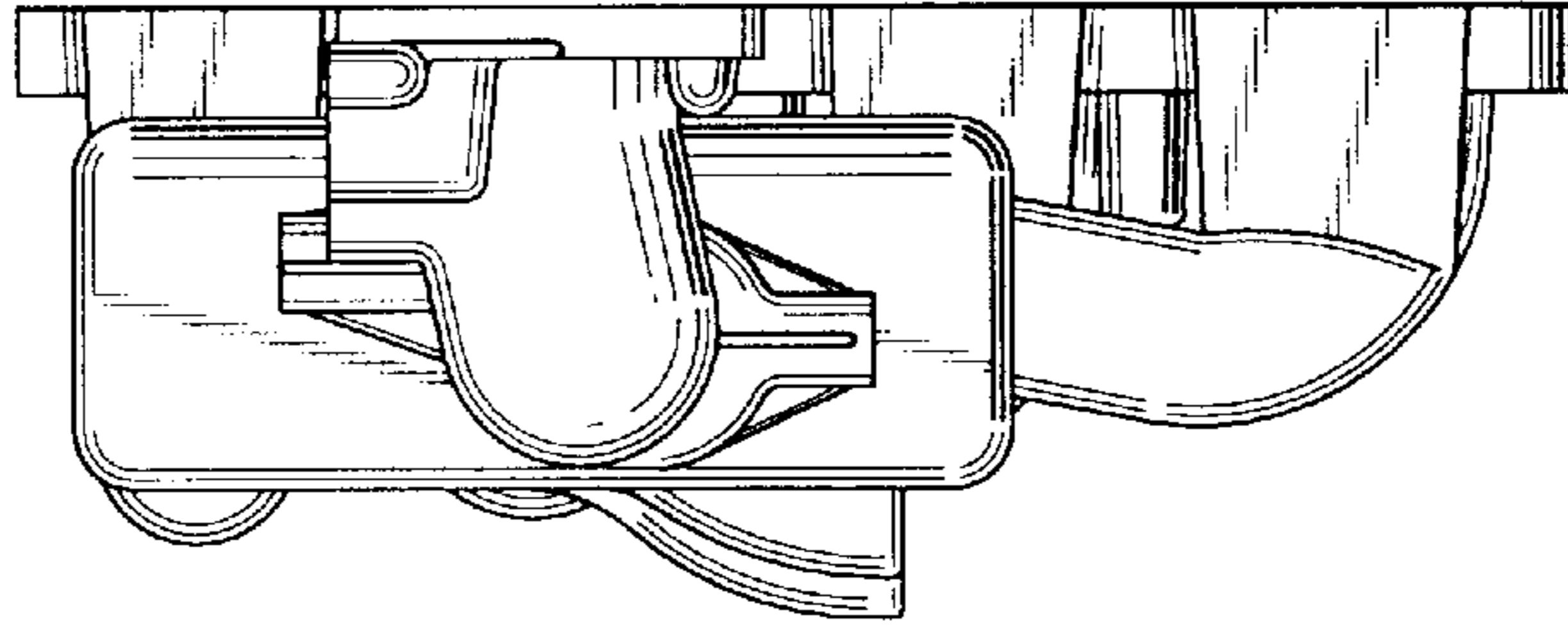

FIG. 13

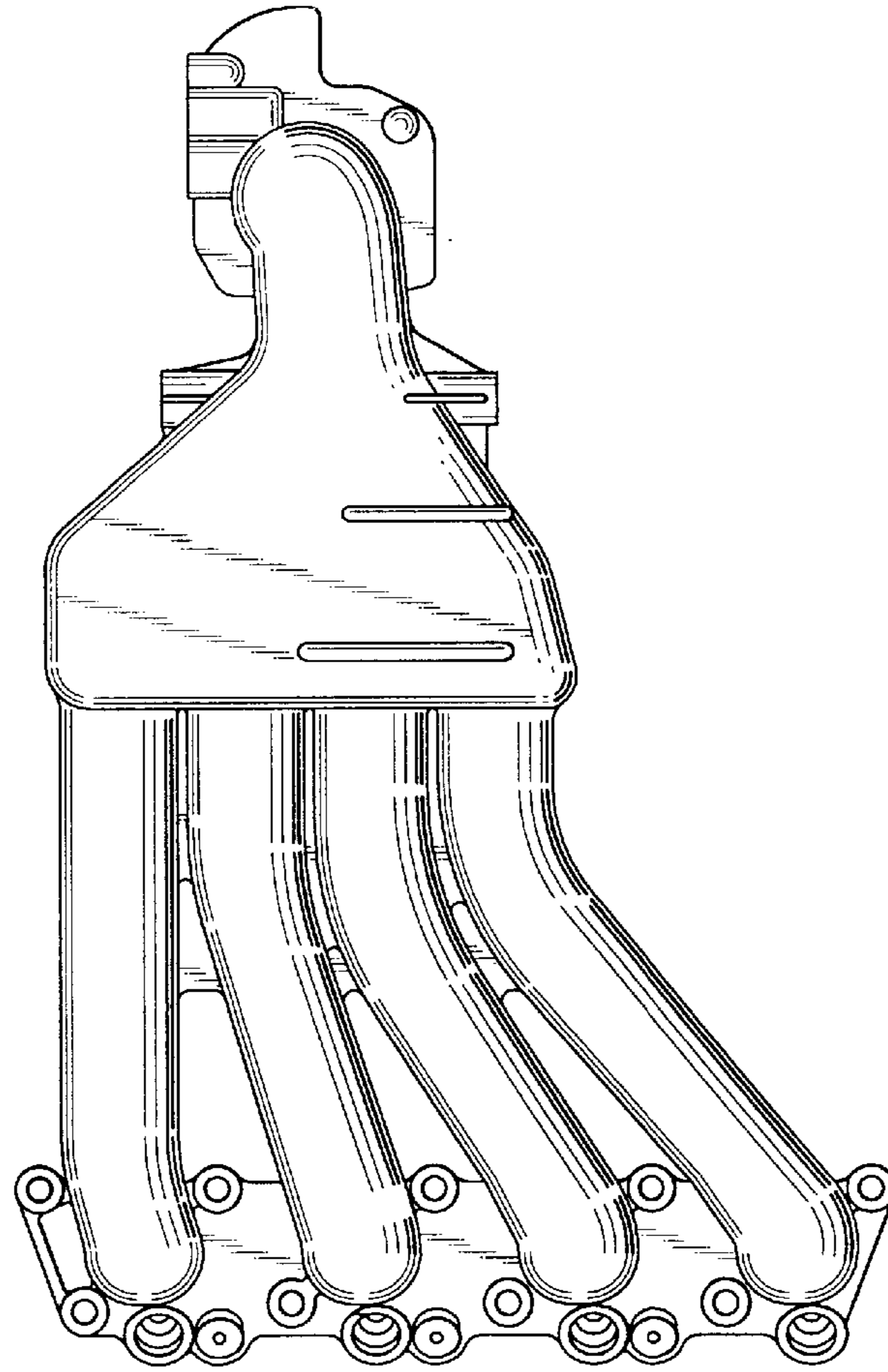

FIG. 14

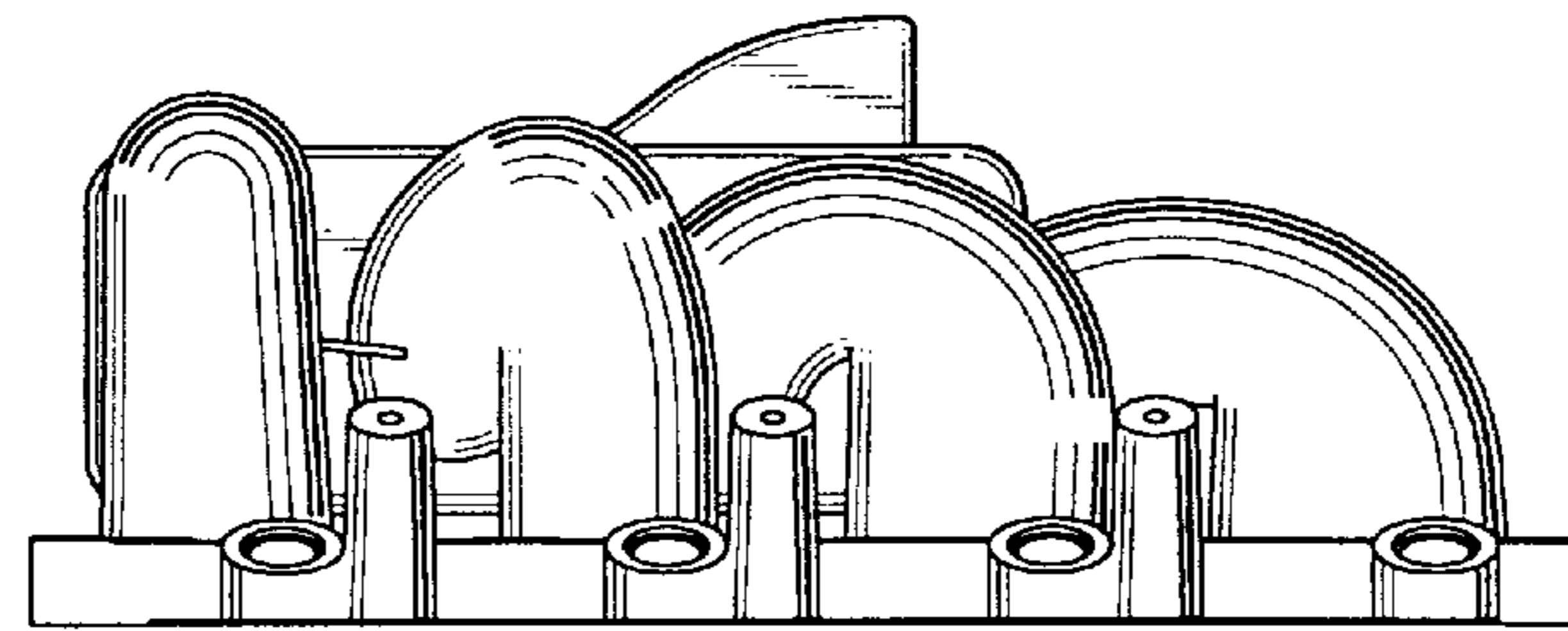

FIG. 16

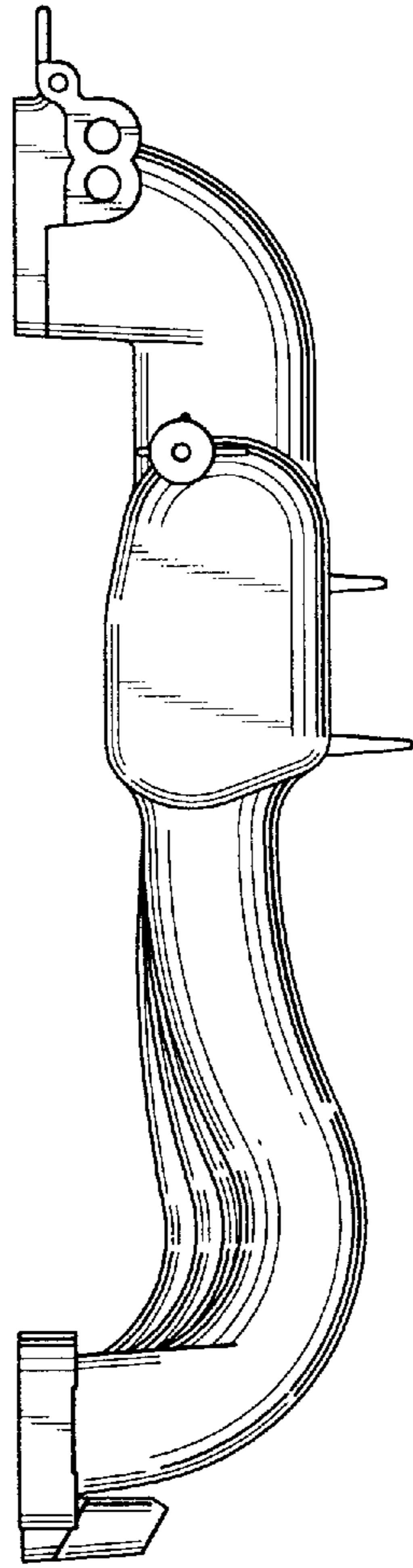

FIG. 17

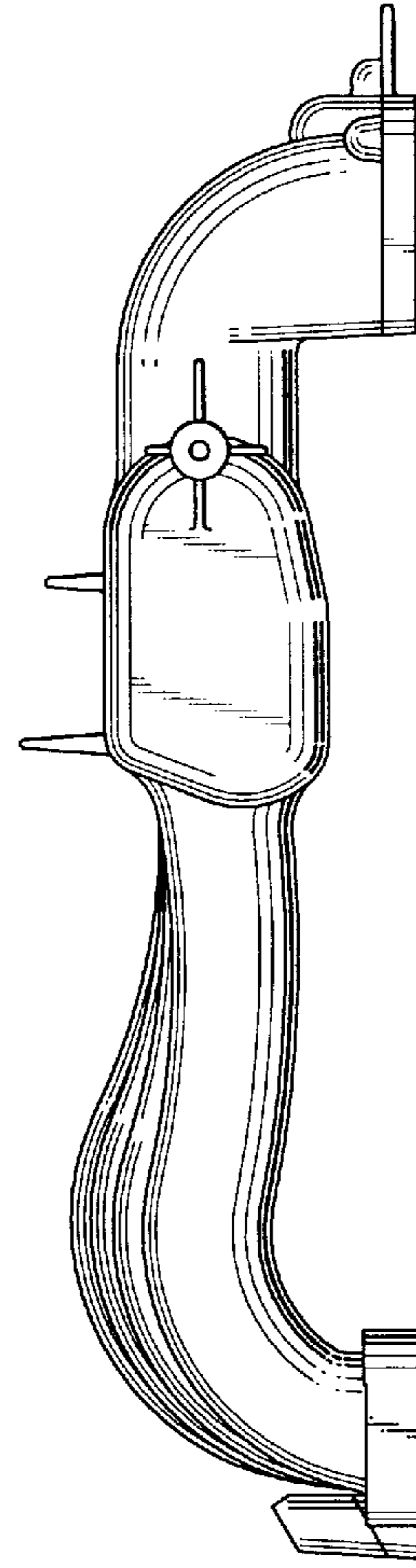

FIG. 18

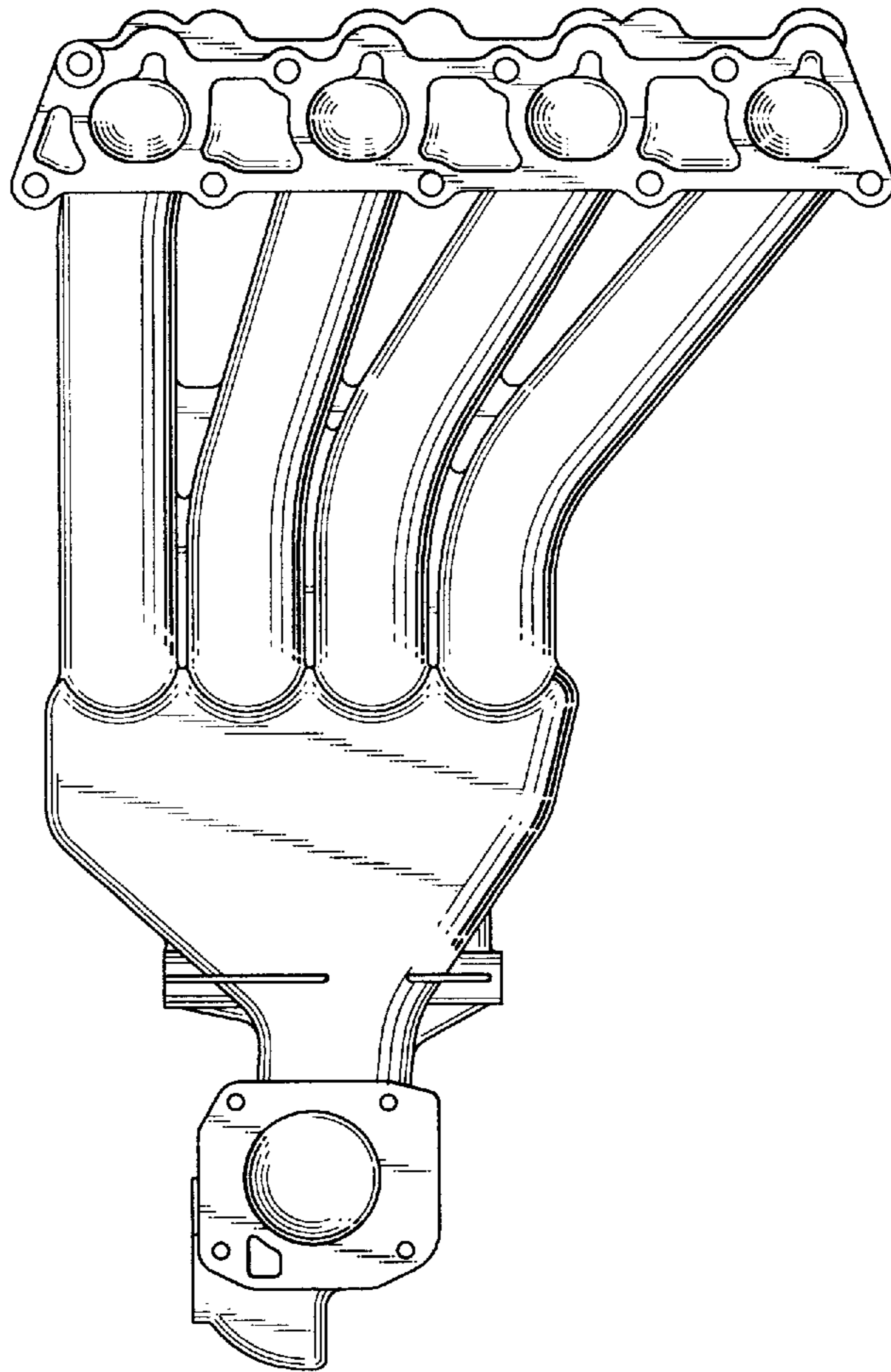

FIG. 21

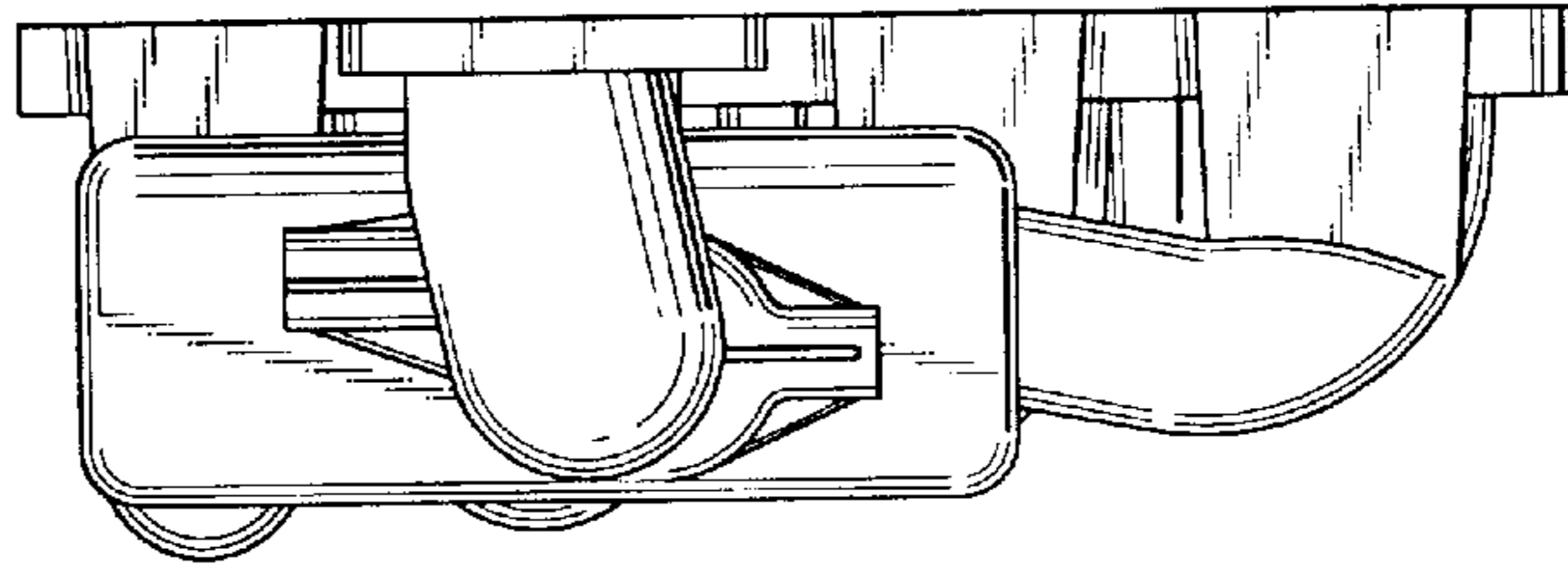

FIG. 19

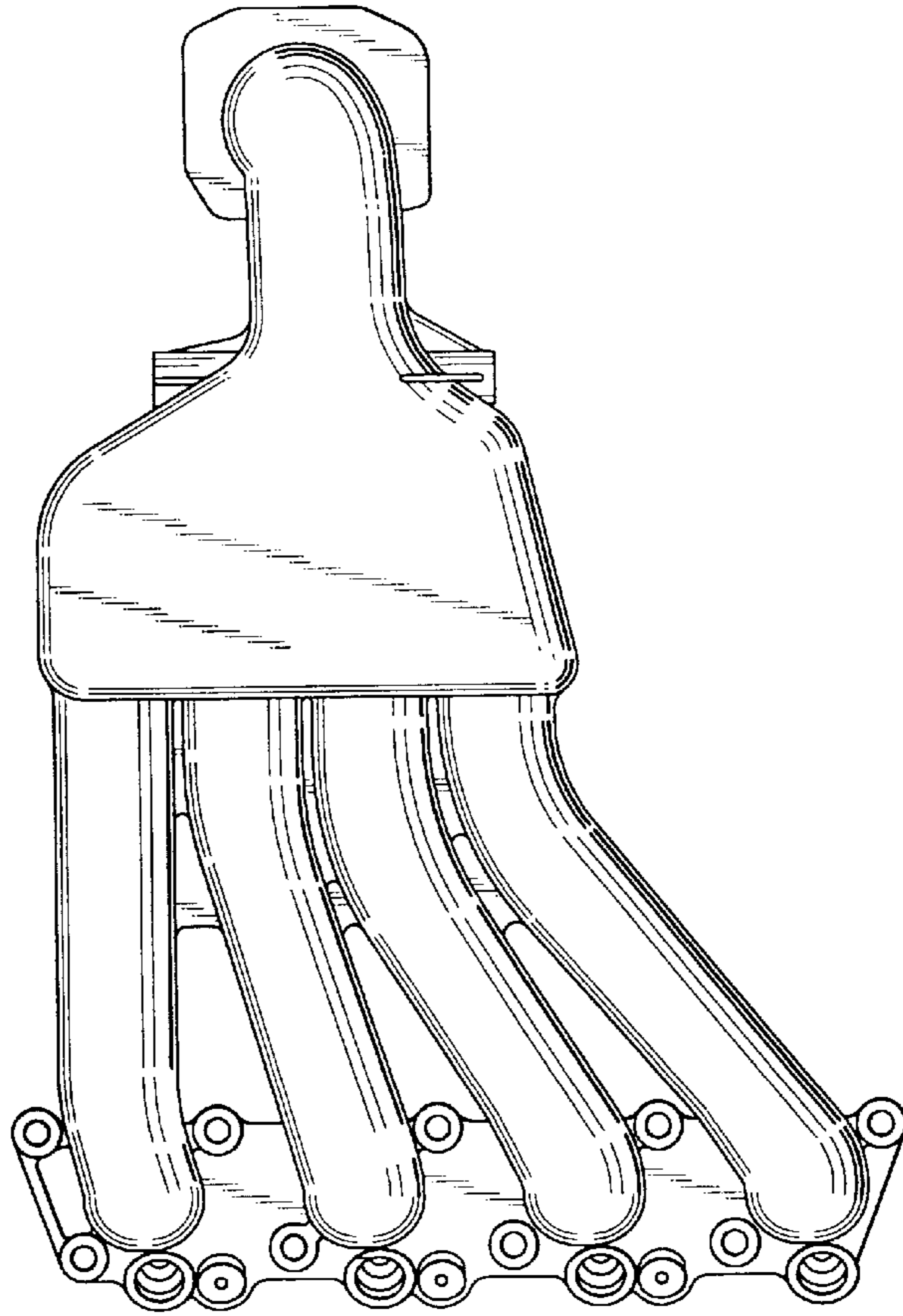

FIG. 20

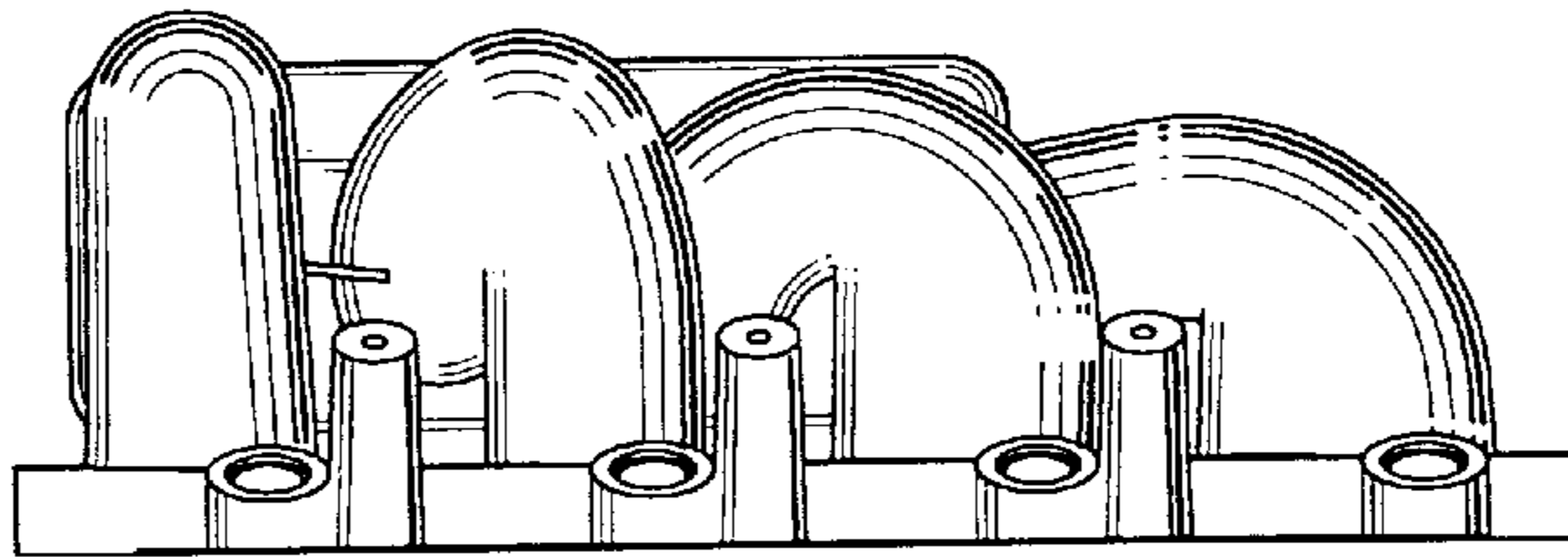

FIG. 22

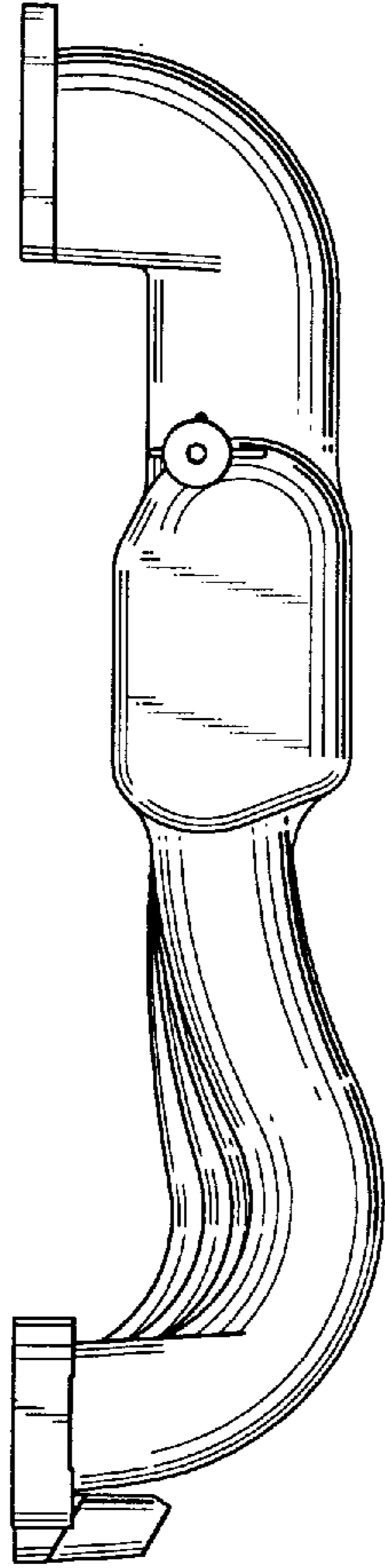

FIG. 23

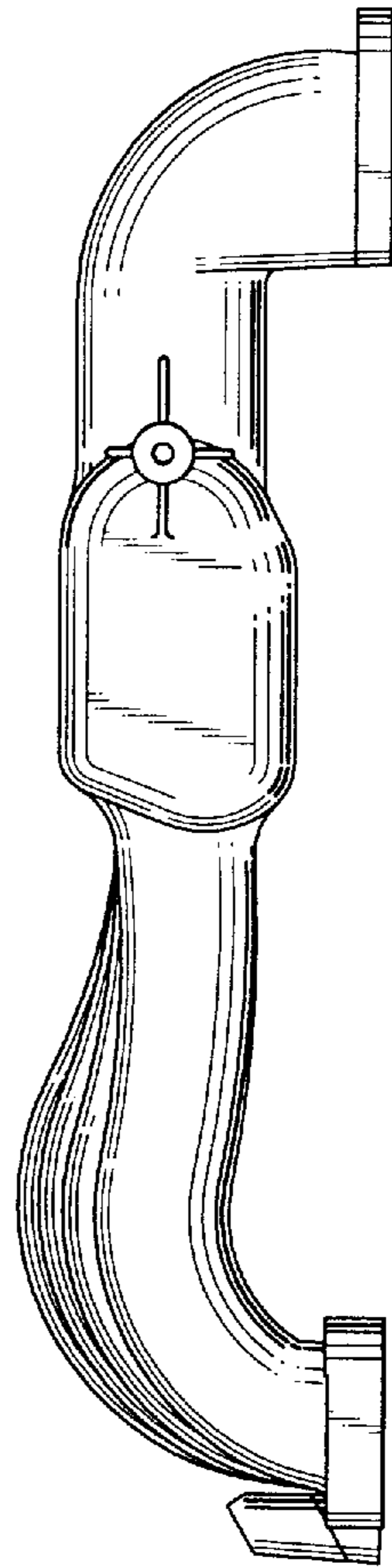

FIG. 24

