



US00D405071S

United States Patent [19] Gambaro

[11] **Patent Number: Des. 405,071**

[45] **Date of Patent: **Feb. 2, 1999**

[54] **CURSOR CONTROL—DATA ENTRY DEVICE**

[76] Inventor: **Thomas L. Gambaro**, P.O. Box 14741, Portland, Oreg. 97214

[**] Term: **14 Years**

[21] Appl. No.: **77,995**

[22] Filed: **Oct. 17, 1997**

[51] **LOC (6) Cl. 14-02**

[52] **U.S. Cl. D14/114; D14/100; D14/116**

[58] **Field of Search D14/100, 105, D14/106, 115; D18/7, 12; 178/18, 19; 235/145 A, 145 R; 341/22, 23; 345/168, 161, 169, 172; 364/708.1; 400/489**

[56] **References Cited**

U.S. PATENT DOCUMENTS

D. 285,200	8/1986	Bressler et al. .	
D. 308,865	6/1990	Weaver et al.	D14/16
D. 334,922	4/1993	Meyerson et al.	D14/115
D. 337,316	7/1993	Ruiten	D14/100
D. 359,040	6/1995	Nakamura et al.	D14/116
2,369,807	2/1945	Solon .	
4,020,527	5/1977	O'Neill .	
4,244,659	1/1981	Malt .	
4,332,493	6/1982	Einbinder .	
4,579,470	4/1986	Casey .	
4,597,681	7/1986	Hodges .	
4,824,268	4/1989	Diernisse .	
4,849,732	7/1989	Dolenc .	
4,913,573	4/1990	Retter .	
5,178,477	1/1993	Gambaro .	
5,332,322	7/1994	Gambaro .	
5,414,251	5/1995	Durbin	235/462

FOREIGN PATENT DOCUMENTS

27 25 677 12/1977 Germany .

OTHER PUBLICATIONS

Uchiyama, "Kana Keyboard With Palm Rest", *IBM Technical Disclosure Bulletin*, vol. 25, No. 9, pp. 4915-4916, Feb. 1983.

Kennedy, "Hand-Held Data Input Device" *IBM Technical Disclosure Bulletin*, vol. 26, No. 11, pp. 5826-5827, Apr. 1984.

Harris Corporation, "Model TS-22", *Telephony*, p. 97, May 11, 1987.

"Telecommuniatio"0 article from technical journal, publication and date unknown.

British printer, Sep. 1977.

Primary Examiner—Freda Nunn

Attorney, Agent, or Firm—Kolisch, Hartwell, Dickinson, McCormack & Heuser

[57] **CLAIM**

The ornamental design for a cursor control-data entry device, as shown and described.

DESCRIPTION

FIG. 1 is an isometric view of a cursor control-data entry device constructed in accordance with a first embodiment of the invention;

FIG. 2 is a top plan view of the cursor control-data entry device of FIG. 1;

FIG. 3 is a right-side view of the cursor control-data entry device of FIG. 1, the left-side being a mirror image thereof; FIG. 4 is a front view of the cursor control-data entry device of FIG. 1;

FIG. 5 is a rear view of the cursor control-data entry device of FIG. 1; and

FIG. 6 is a bottom view of the cursor control-data entry device of FIG. 1;

FIG. 7 is an isometric view of a cursor control-data entry device constructed in accordance with a second embodiment of the invention;

FIG. 8 is a top plan view of the cursor control-data entry device of FIG. 7;

FIG. 9 is a right-side view of the cursor control-data entry device of FIG. 7, the left-side view being a mirror image thereof;

FIG. 10 is a front view of the cursor control-data entry device of FIG. 7;

FIG. 11 is a rear view of the cursor control-data entry device of FIG. 7; and,

FIG. 12 is a bottom view of the cursor control-data entry device of FIG. 7.

1 Claim, 3 Drawing Sheets

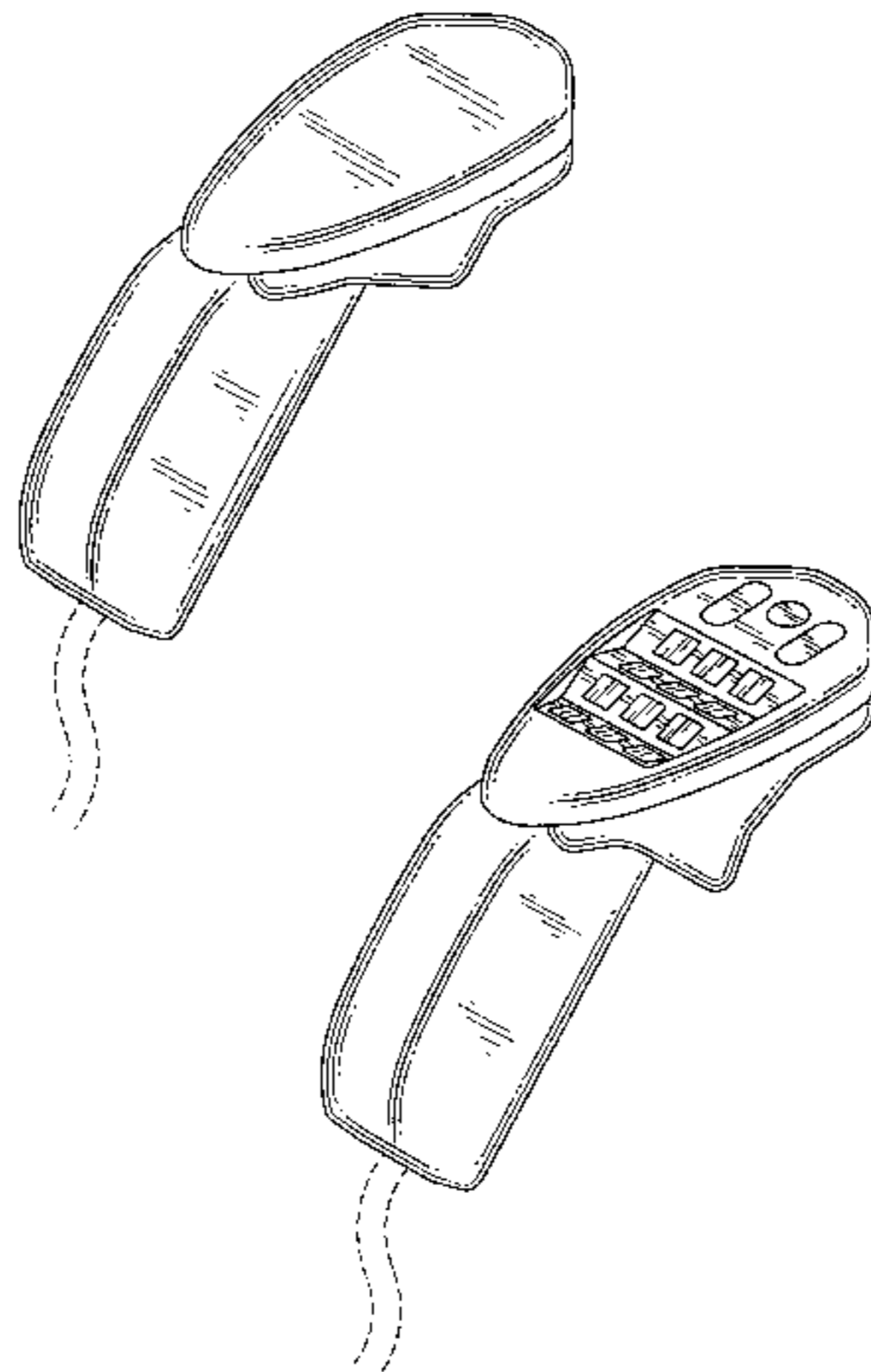

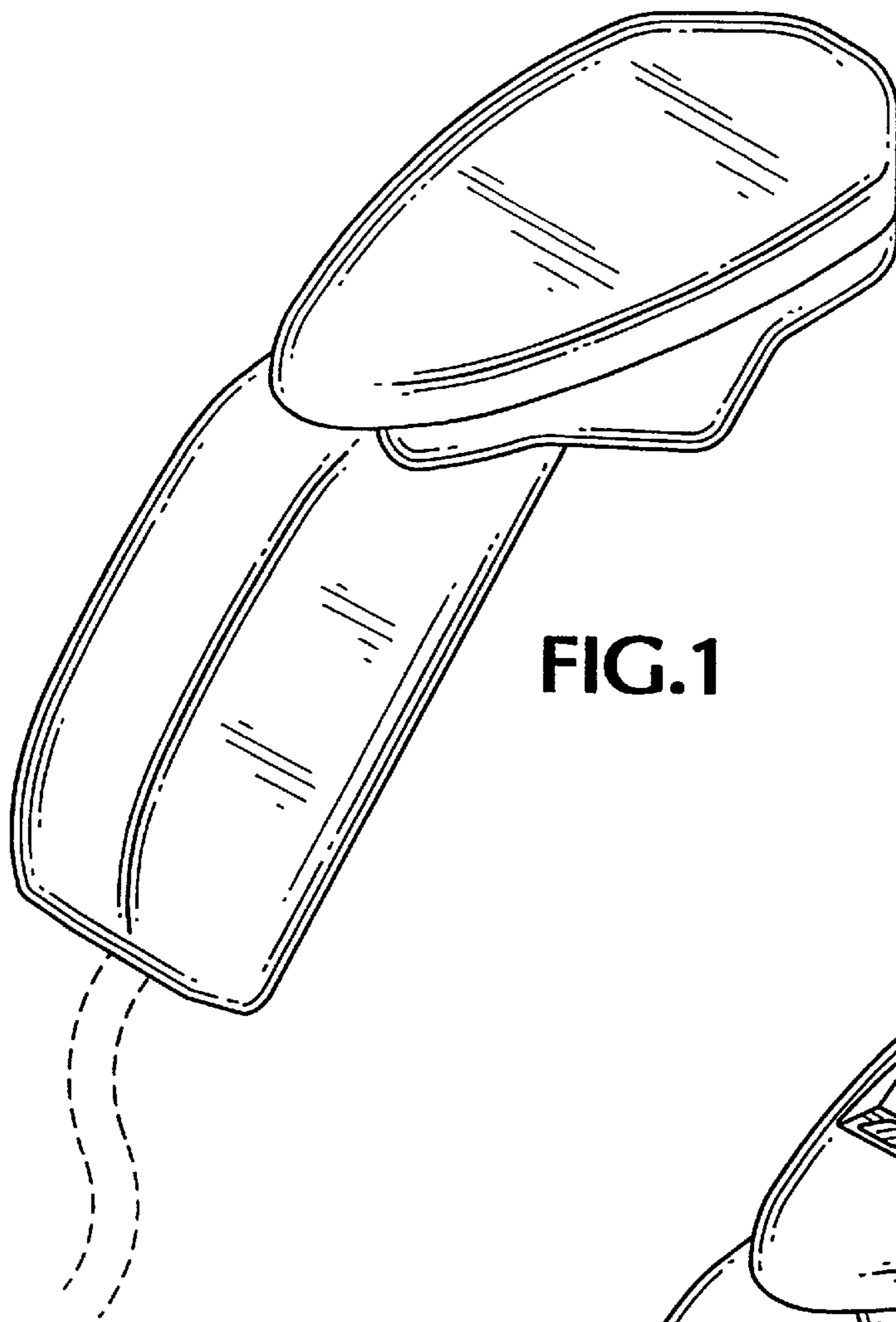

FIG. 1

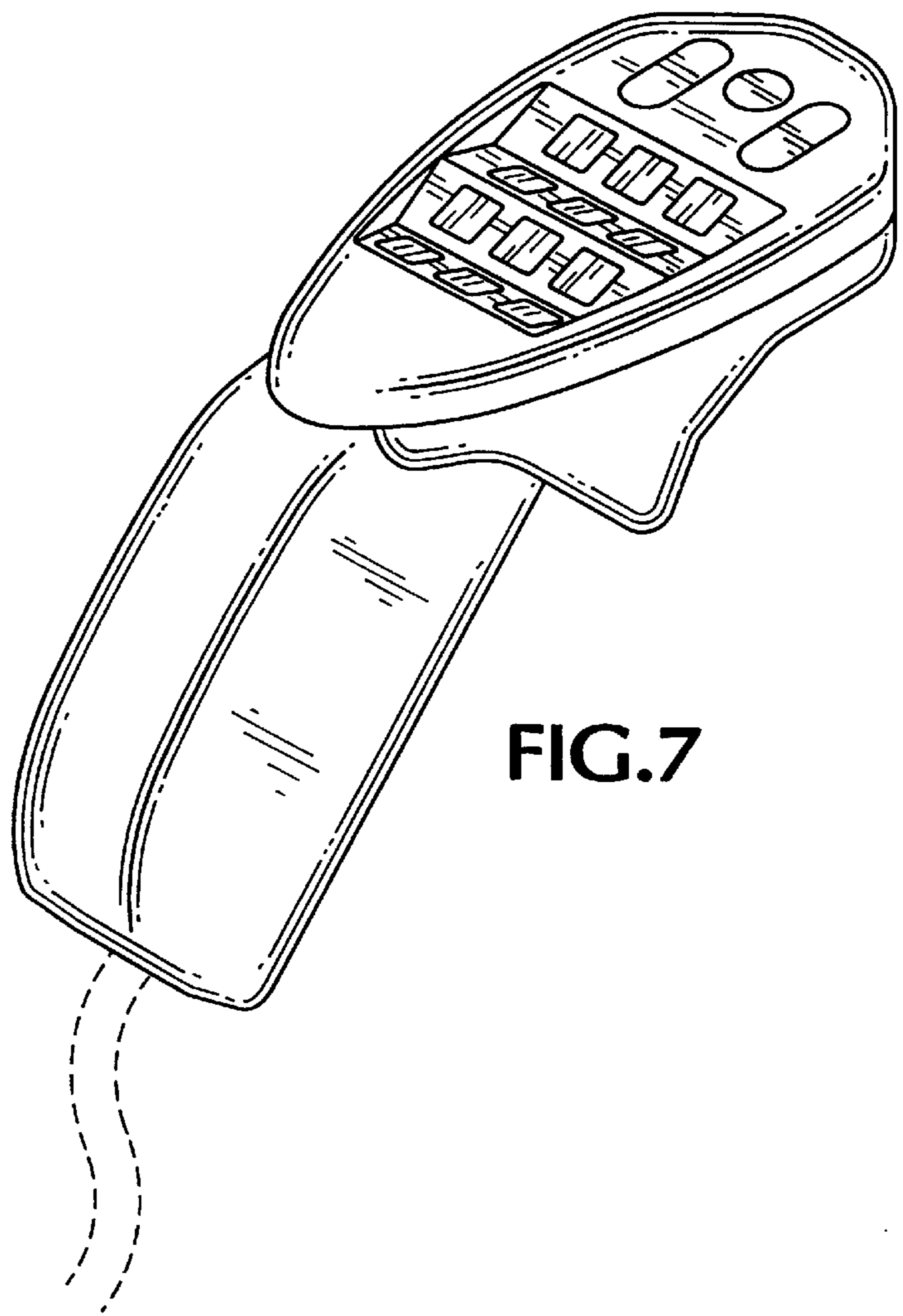

FIG. 7

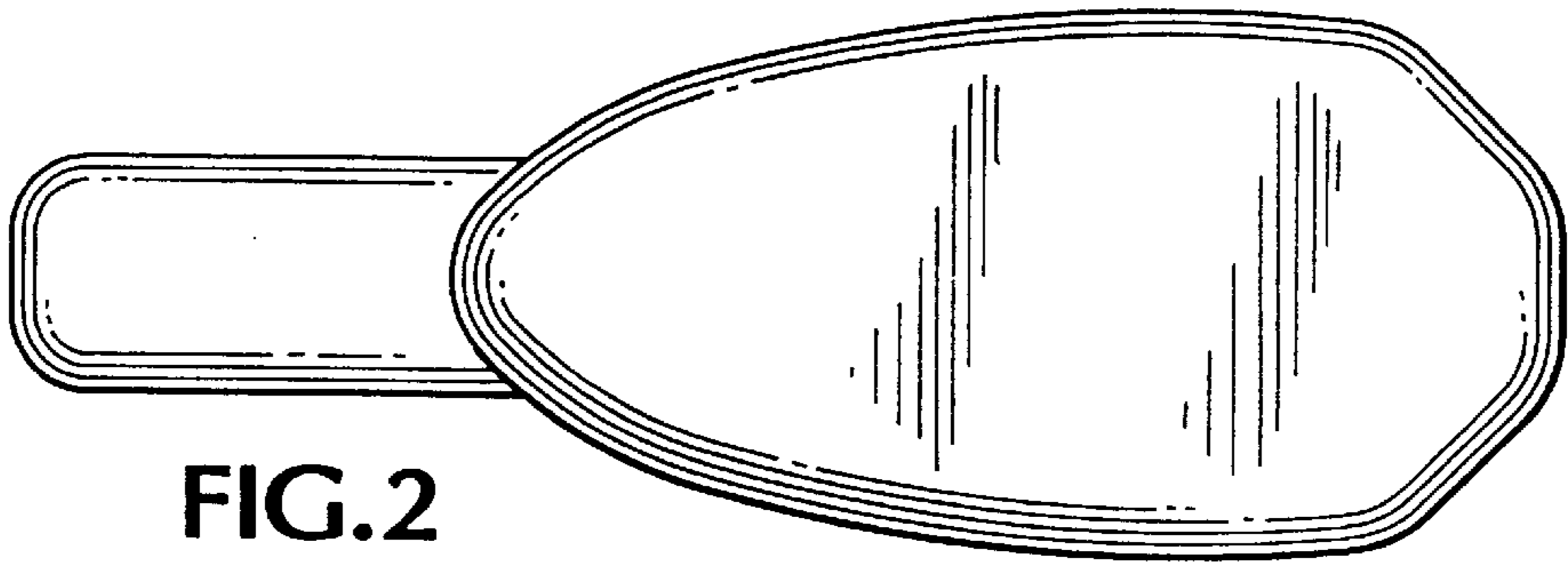

FIG. 2

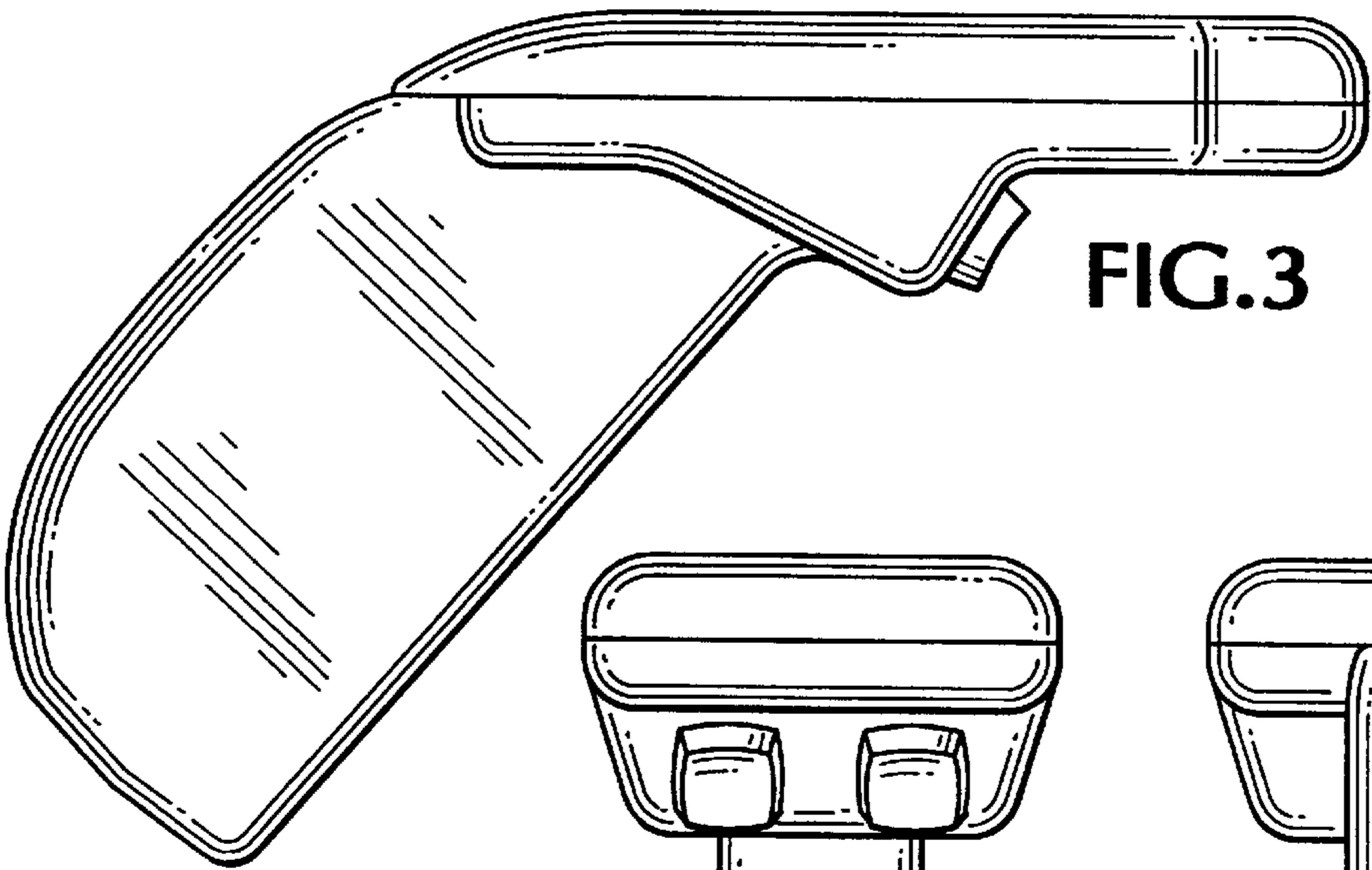

FIG. 3

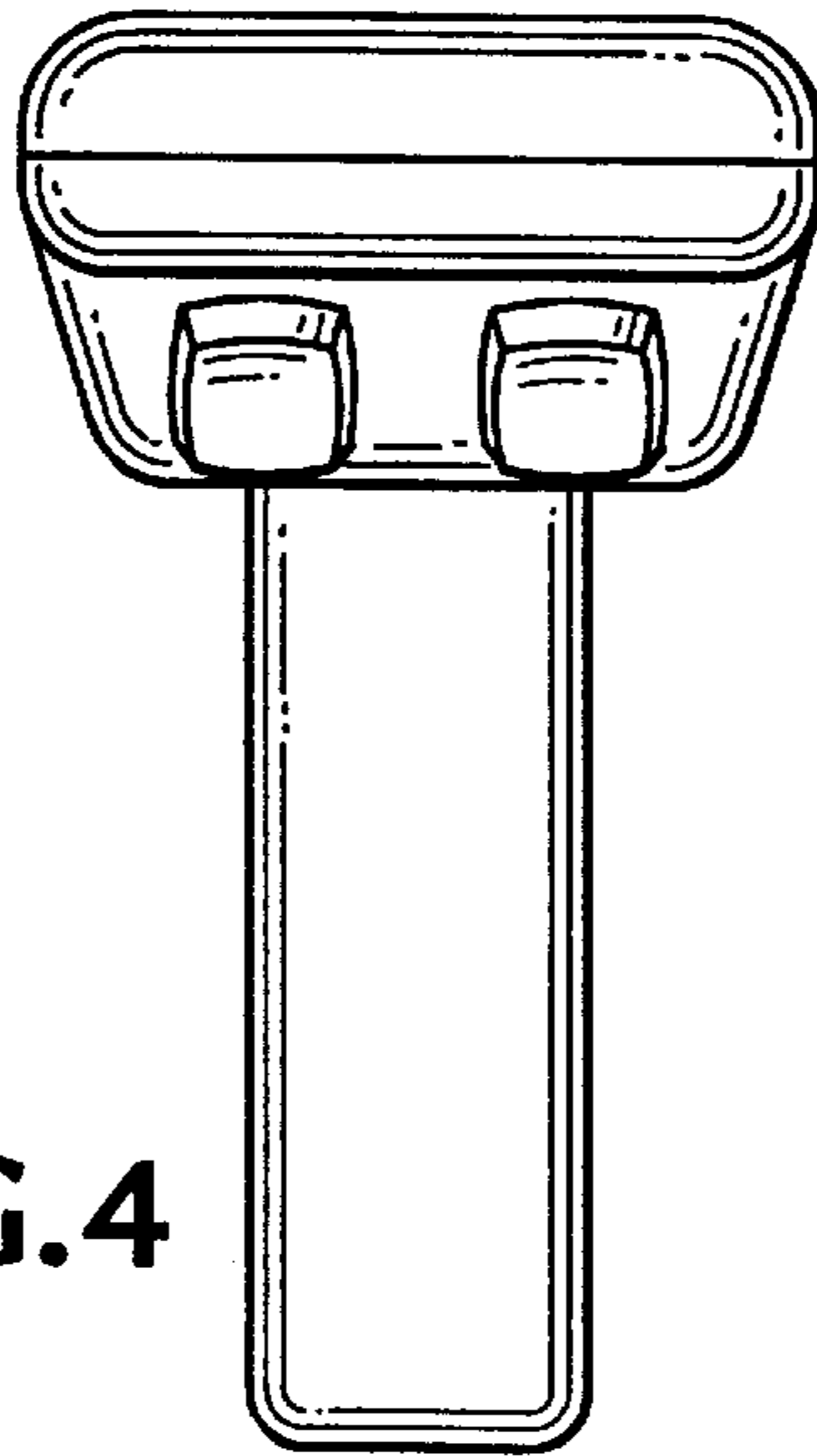

FIG. 4

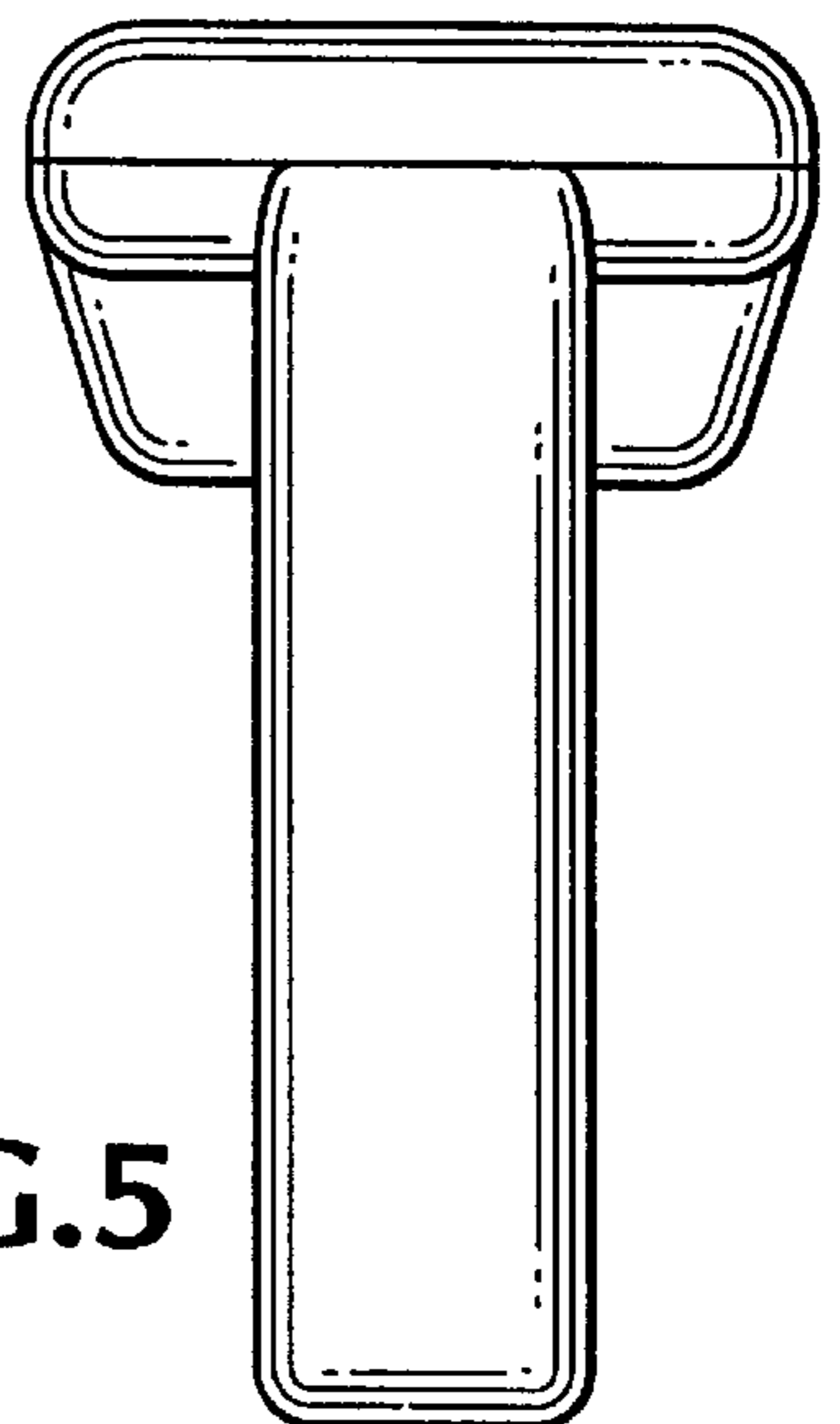

FIG. 5

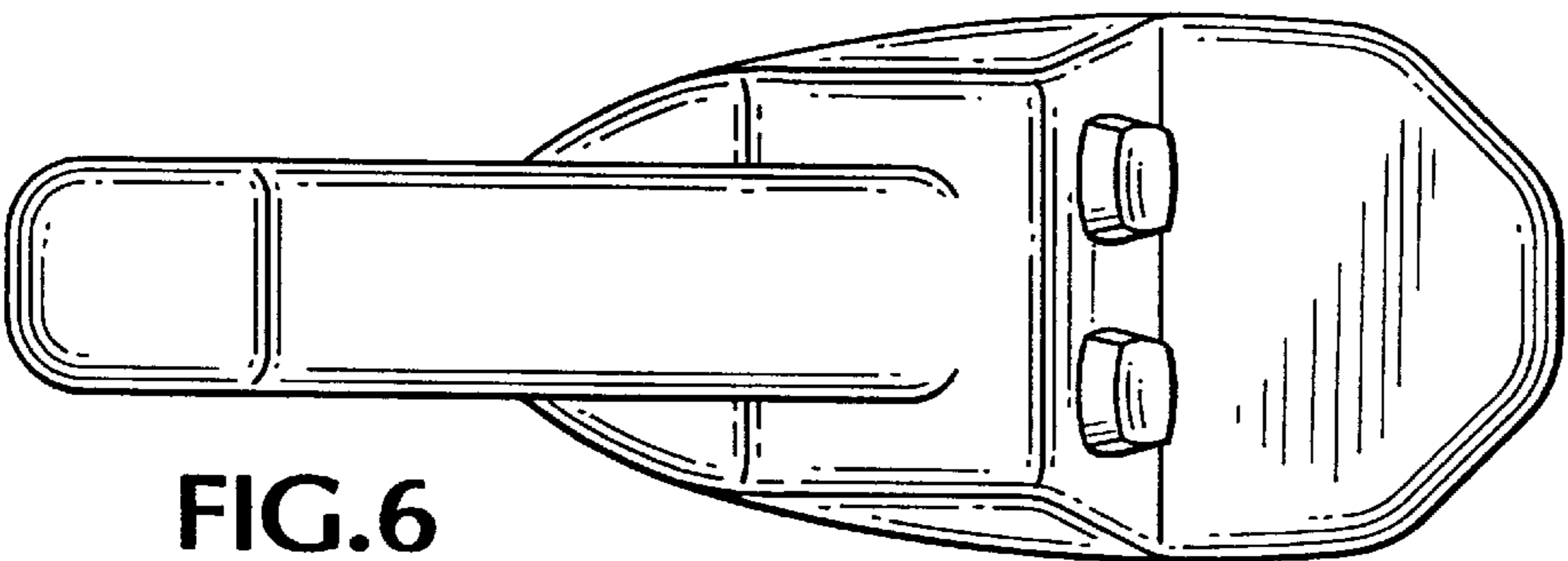

FIG. 6

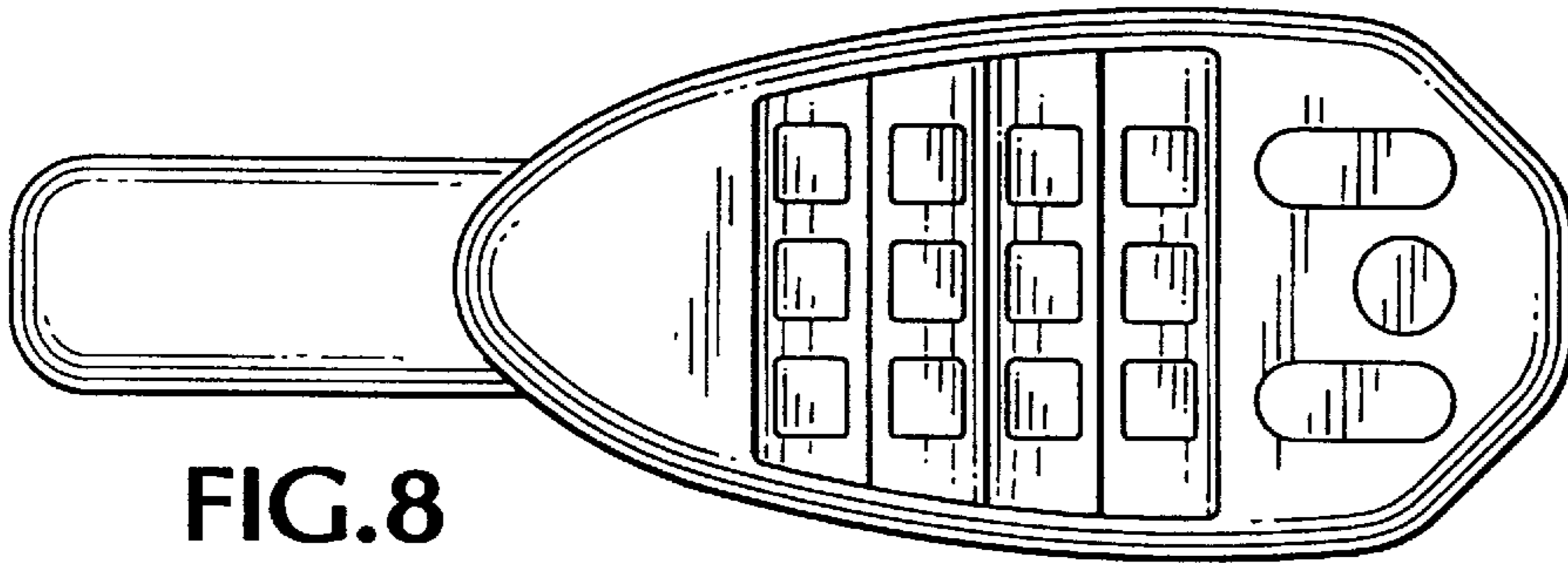

FIG. 8

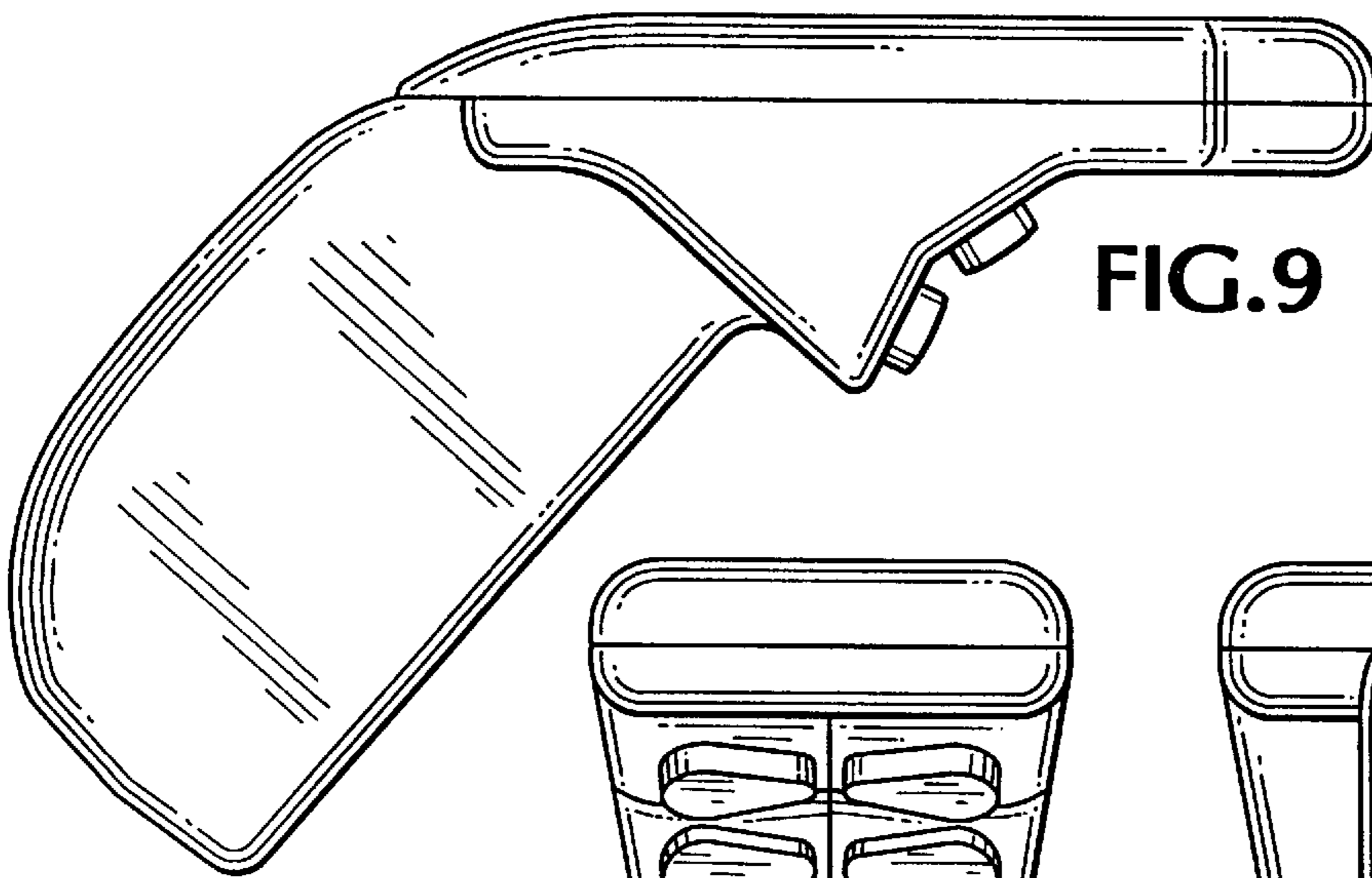

FIG. 9

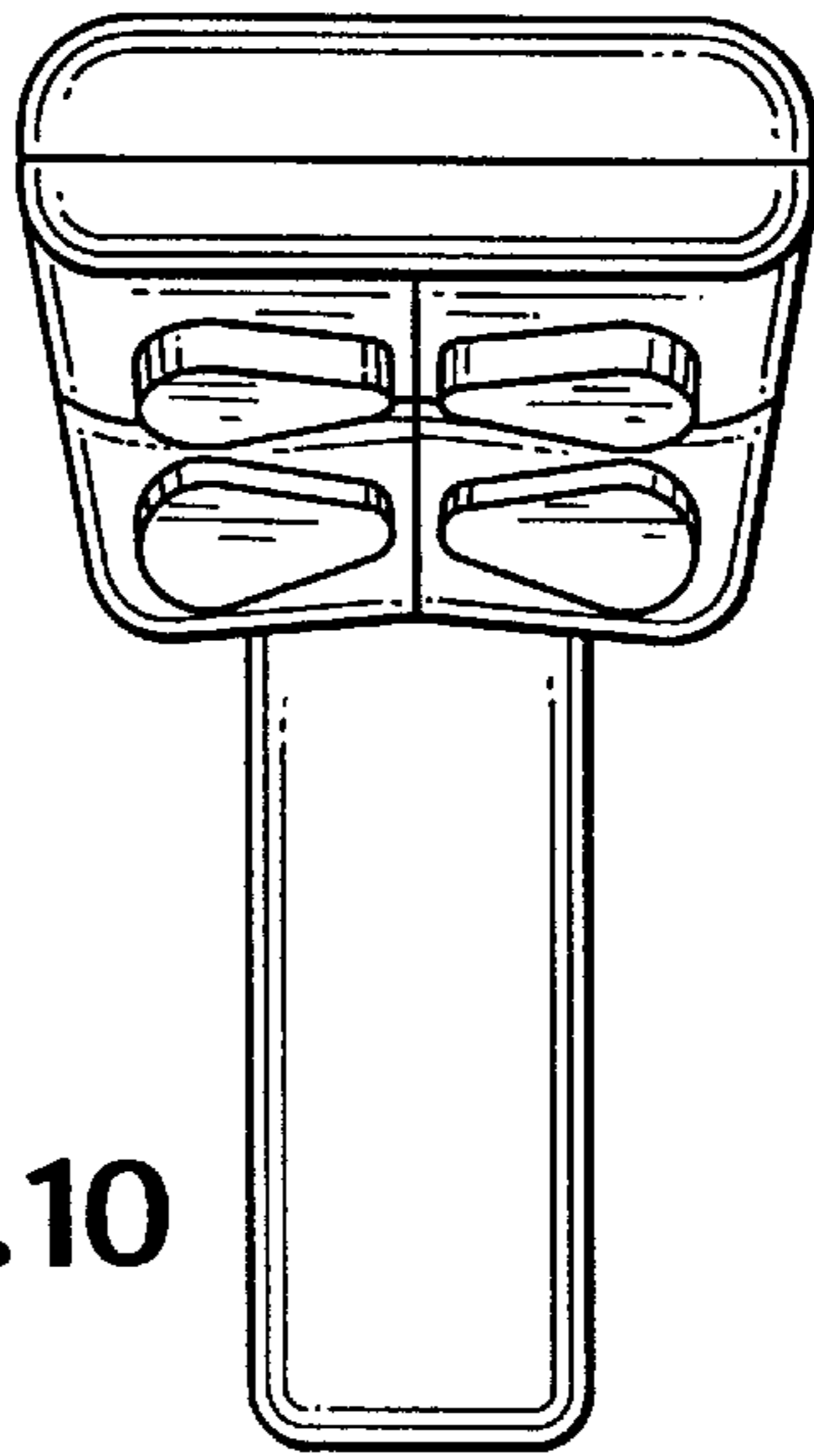

FIG. 10

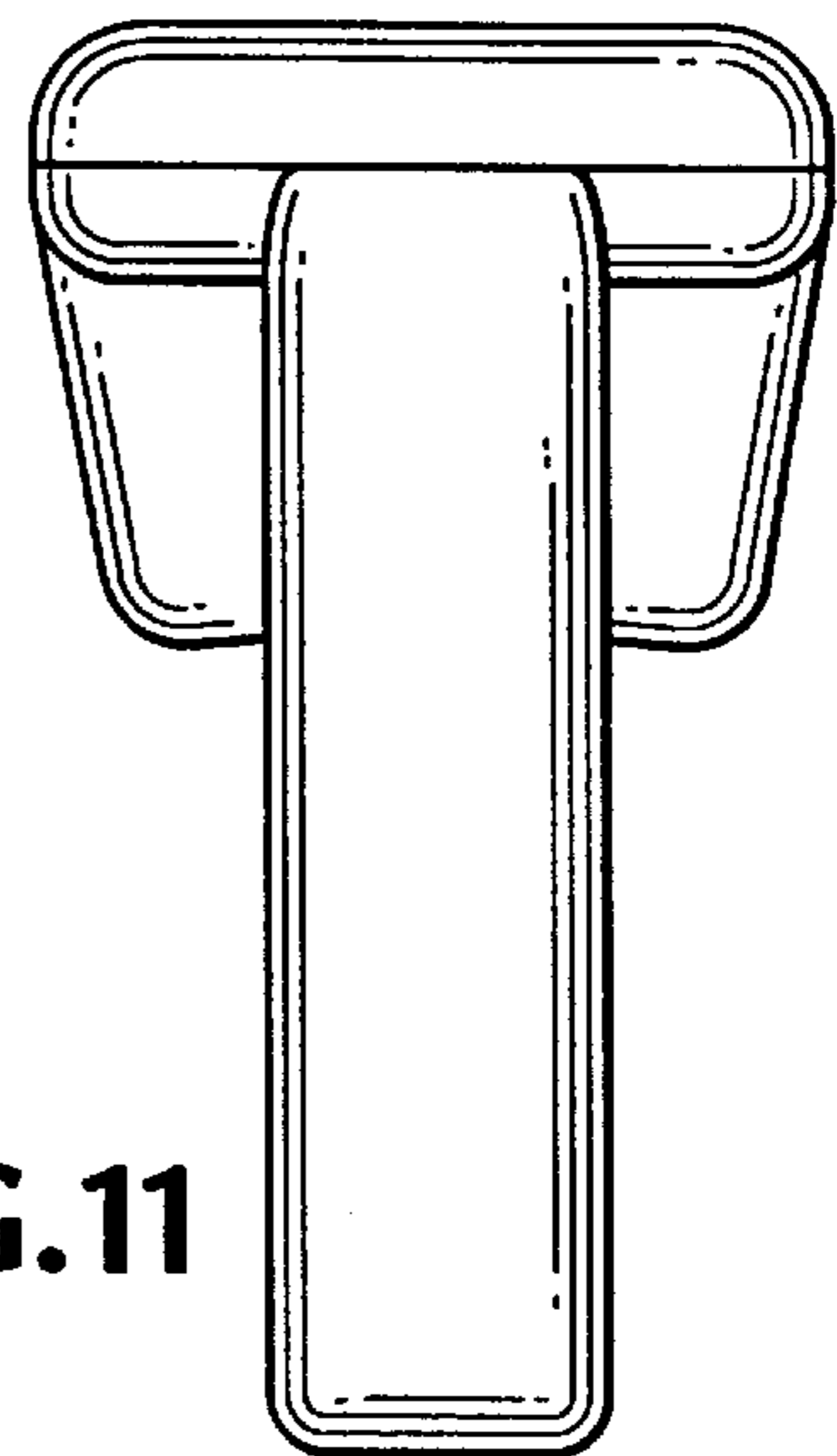

FIG. 11

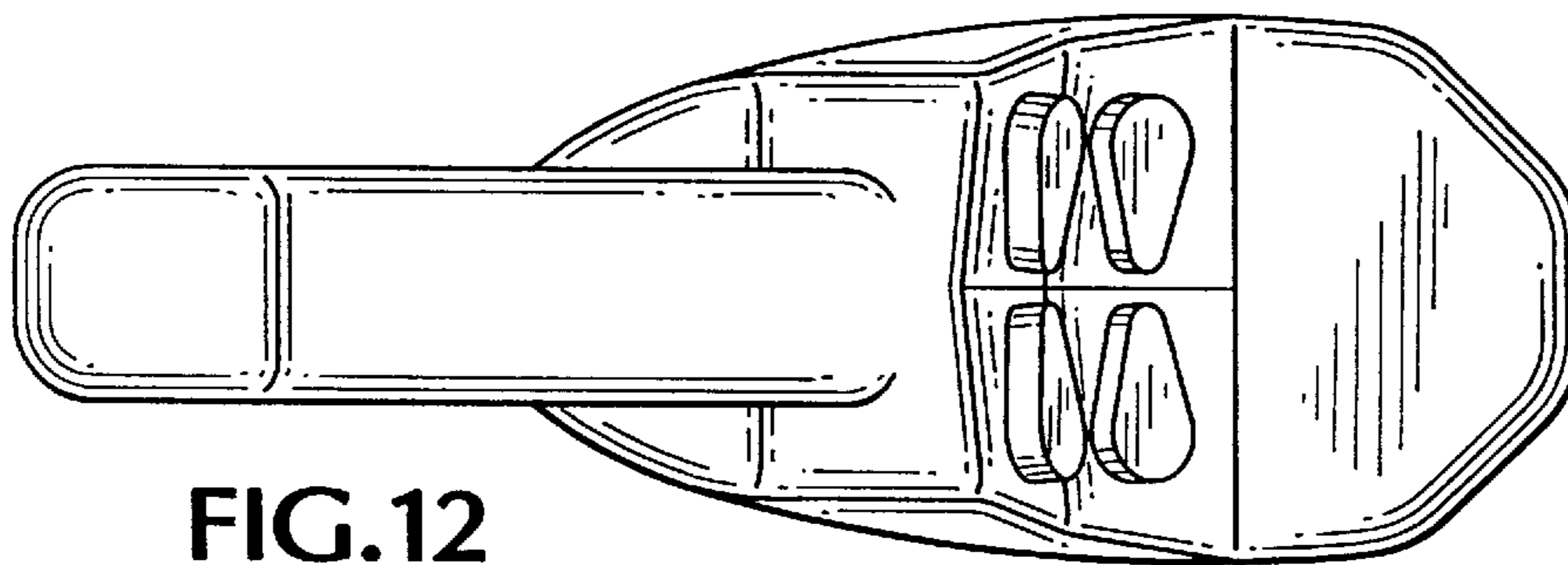

FIG. 12