



US00D405029S

United States Patent [19]

Deutschman

[11] **Patent Number: Des. 405,029**

[45] **Date of Patent: **Feb. 2, 1999**

[54] **ALL TERRAIN VEHICLE BODY**

[75] Inventor: **Paul Deutschman**, Quebec, Canada

[73] Assignee: **Bombardier, Inc.**, Montreal, Canada

[**] Term: **14 Years**

[21] Appl. No.: **64,911**

[22] Filed: **Jan. 14, 1997**

[51] **LOC (6) Cl. 12-11**

[52] **U.S. Cl. D12/107**

[58] **Field of Search D12/107, 3; 180/233, 180/311, 312, 225, 229, 315**

[56] **References Cited**

U.S. PATENT DOCUMENTS

- D. 297,132 8/1988 Ryuzoje et al. D12/107
- D. 298,113 10/1988 Tamura et al. D12/107
- D. 298,811 12/1988 Morito D12/107
- D. 305,999 2/1990 Ueda et al. D12/107

- D. 327,457 6/1992 Saito D12/107
- D. 330,694 11/1992 Kimuna et al. D12/107

Primary Examiner—Melody N. Brown
Attorney, Agent, or Firm—St. Onge Steward Johnston & Reens LLC

[57] **CLAIM**

I claim the ornamental design of an all terrain vehicle body, as shown.

DESCRIPTION

FIG. 1 is a perspective view of an all terrain vehicle body showing my new design, the broken lines are shown for illustrative purpose only and form no part of the claimed design;

FIG. 2 is a right side elevational view, the left side elevational view being a mirror image thereof;

FIG. 3 is a top plan view thereof;

FIG. 4 is a front elevational view thereof; and,

FIG. 5 is a rear elevational view thereof.

1 Claim, 3 Drawing Sheets

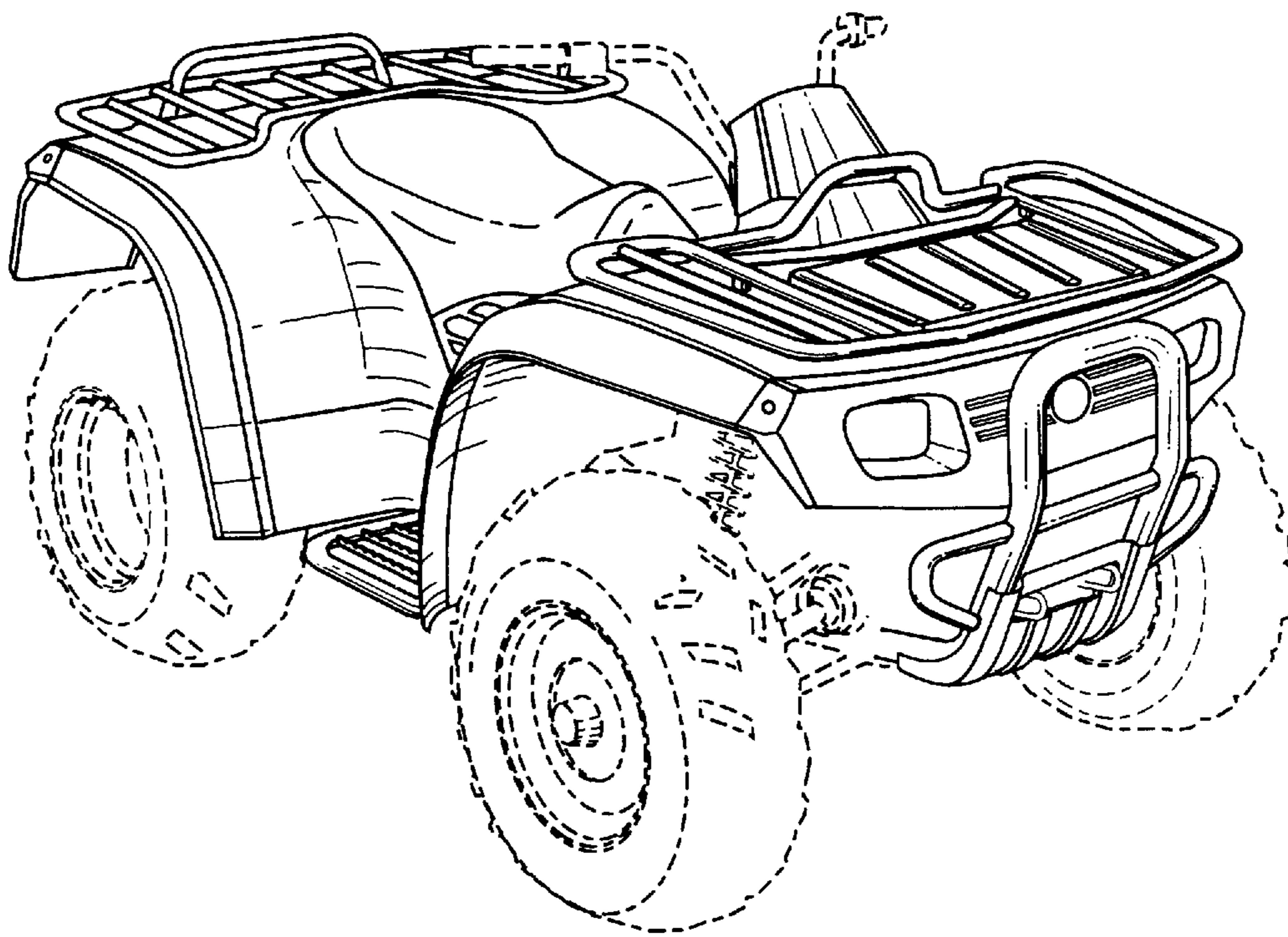

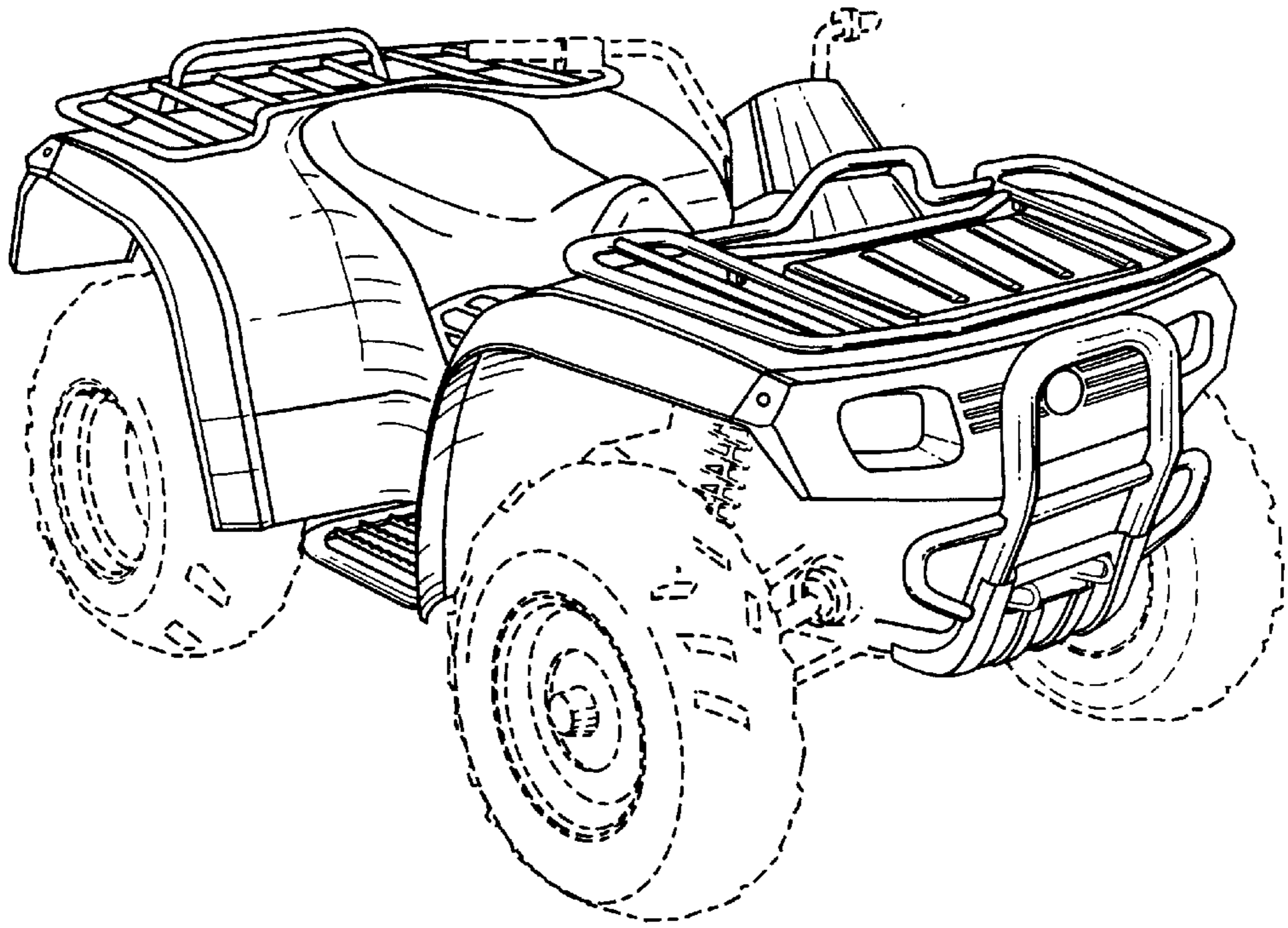

Fig. 1

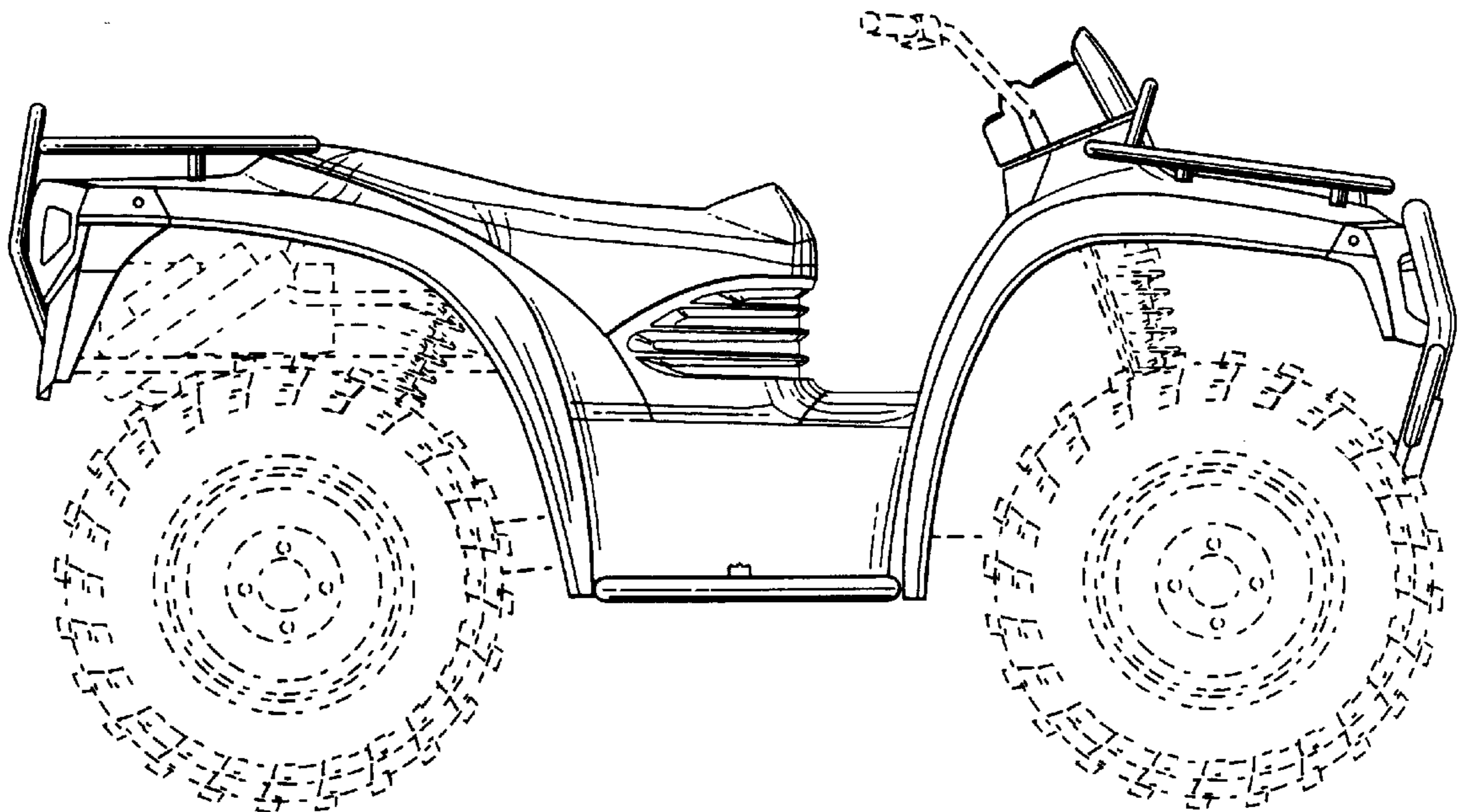

Fig. 2

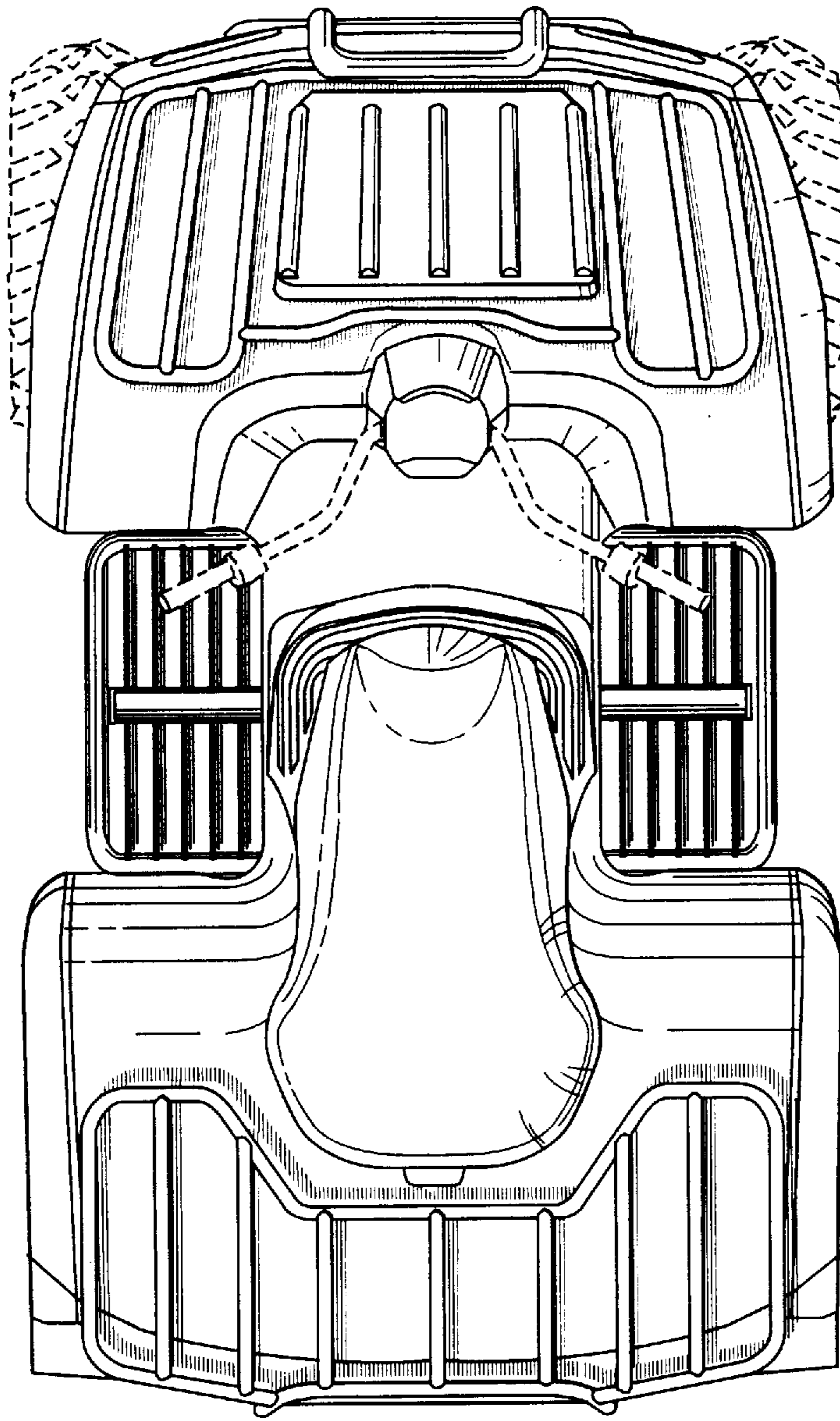

Fig. 3

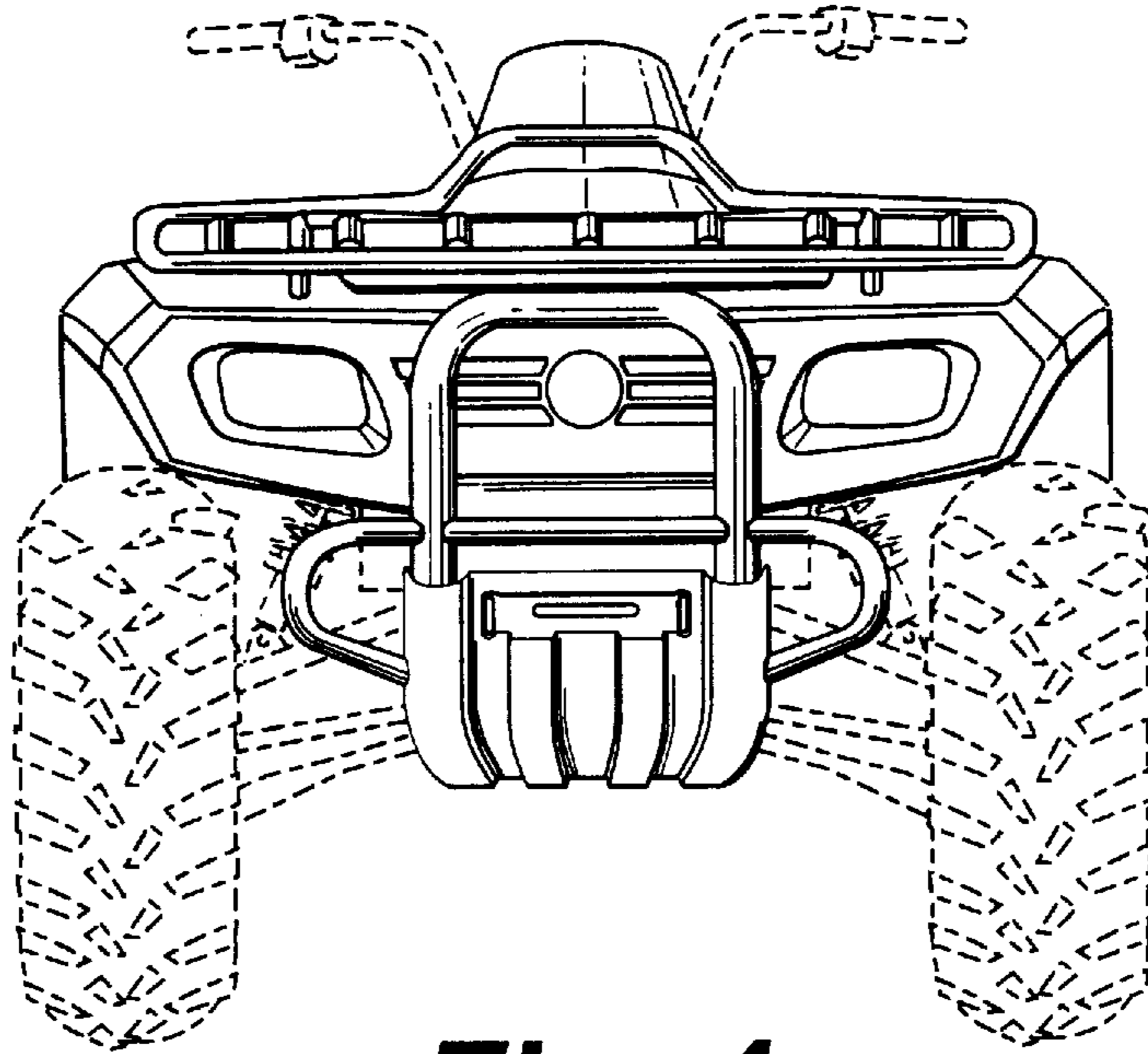

Fig. 4

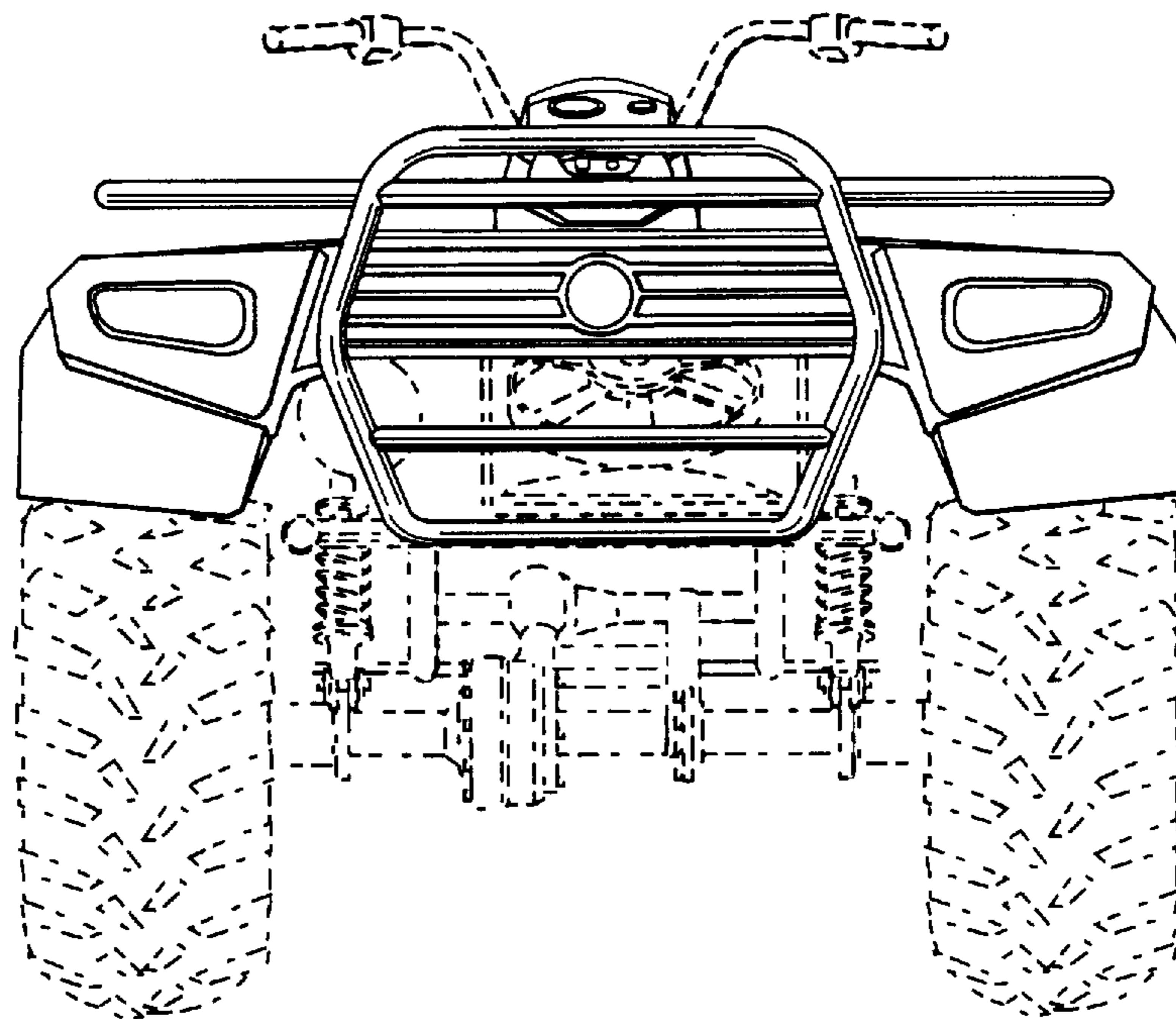

Fig. 5