



US00D404949S

United States Patent [19]
Hamami

[11] **Patent Number: Des. 404,949**

[45] **Date of Patent: **Feb. 2, 1999**

[54] **FRONT AND REAR FRAME PORTIONS OF AUDIO/VIDEO STORAGE UNIT**

[76] Inventor: **Demir Hamami**, 5601 Huntington Pkwy., Bethesda, Md. 20814

[**] Term: **14 Years**

[21] Appl. No.: **96,087**

[22] Filed: **Nov. 6, 1998**

Related U.S. Application Data

[62] Division of Ser. No. 62,371, Nov. 14, 1996, Pat. No. Des. 403,539, which is a division of Ser. No. 52,634, Apr. 4, 1996, Pat. No. Des. 378,175.

[51] **LOC (6) Cl. 06-06**

[52] **U.S. Cl. D6/491; D6/509**

[58] **Field of Search** D6/479, 478, 477, D6/473, 474, 467, 468, 484, 487, 482, 491, 509, 492, 494, 300, 310; 211/186, 135; 248/174; 108/184; 312/238, 223.1

[56] **References Cited**

U.S. PATENT DOCUMENTS

D. 186,382	10/1959	Herrmann	D6/494
D. 271,646	12/1983	Thompson	.	
D. 294,787	3/1988	Berry, Jr.	.	
D. 300,701	4/1989	Jonker	.	
D. 325,137	4/1992	Porter	.	
D. 333,749	3/1993	Leonard	.	
D. 335,051	4/1993	Ossip	.	
D. 343,082	1/1994	Sayad	D6/509
D. 363,626	10/1995	Herbst	.	
D. 371,259	7/1996	Herbst	.	
D. 371,472	7/1996	Herbst	.	
D. 378,175	2/1997	Hamami	.	
3,648,627	3/1972	Schliemann et al.	.	
4,056,897	11/1977	Pearce et al.	.	
4,182,244	1/1980	Hutchines, Jr. et al.	.	
4,961,506	10/1990	Lang	.	
5,083,844	1/1992	Gruenberg et al.	.	

OTHER PUBLICATIONS

Audio Magic Productions MS-4 rack, *Home Theatre*, May 1996, p. 64.

Atlantis Reference audio rack, *Home Theatre*, May 1996, p. 70.

Lovan Sovereign AVR video rack, *Home Theatre*, May 1996, p. 72.

Target D5A component rack, *Home Theatre*, May 1996, p. 74.

Bell'Oggetti B-708 Arco TV stand, *Home Theatre Buyer's Guide*, Summer 1996, p. 122.

Nomi Designs, Contemporary Home Entertainment Furniture brochure, Models Bravo, Cello, Tempo, Concerto and Futuro, date prior to filing date. Nov. 6, 1998.

Stereo Review, p. 155, Canoe ad, rack at bottom right, Feb. 1996.

Stereo Review, p. 88, Bell'Ogetti ad, rack at bottom right AVS-767, Sep. 1995.

Primary Examiner—Jeffrey Asch

[57] **CLAIM**

The ornamental design for front and rear frame portions of audio/video storage unit, as shown and described.

DESCRIPTION

FIG. 1 is a front view of front and rear frame portions of audio/video storage unit showing my new design;

FIG. 2 is a rear view thereof;

FIG. 3 is a left side view thereof, the right side being a mirror image;

FIG. 4 is a front view of a second embodiment showing my new design;

FIG. 5 is a rear view thereof;

FIG. 6 is a left side view thereof, the right side being a mirror image;

FIG. 7 is a perspective view of a third embodiment showing my new design;

FIG. 8 is a front view thereof;

FIG. 9 rear view thereof;

FIG. 10 is a left side view thereof, the right side being a mirror image;

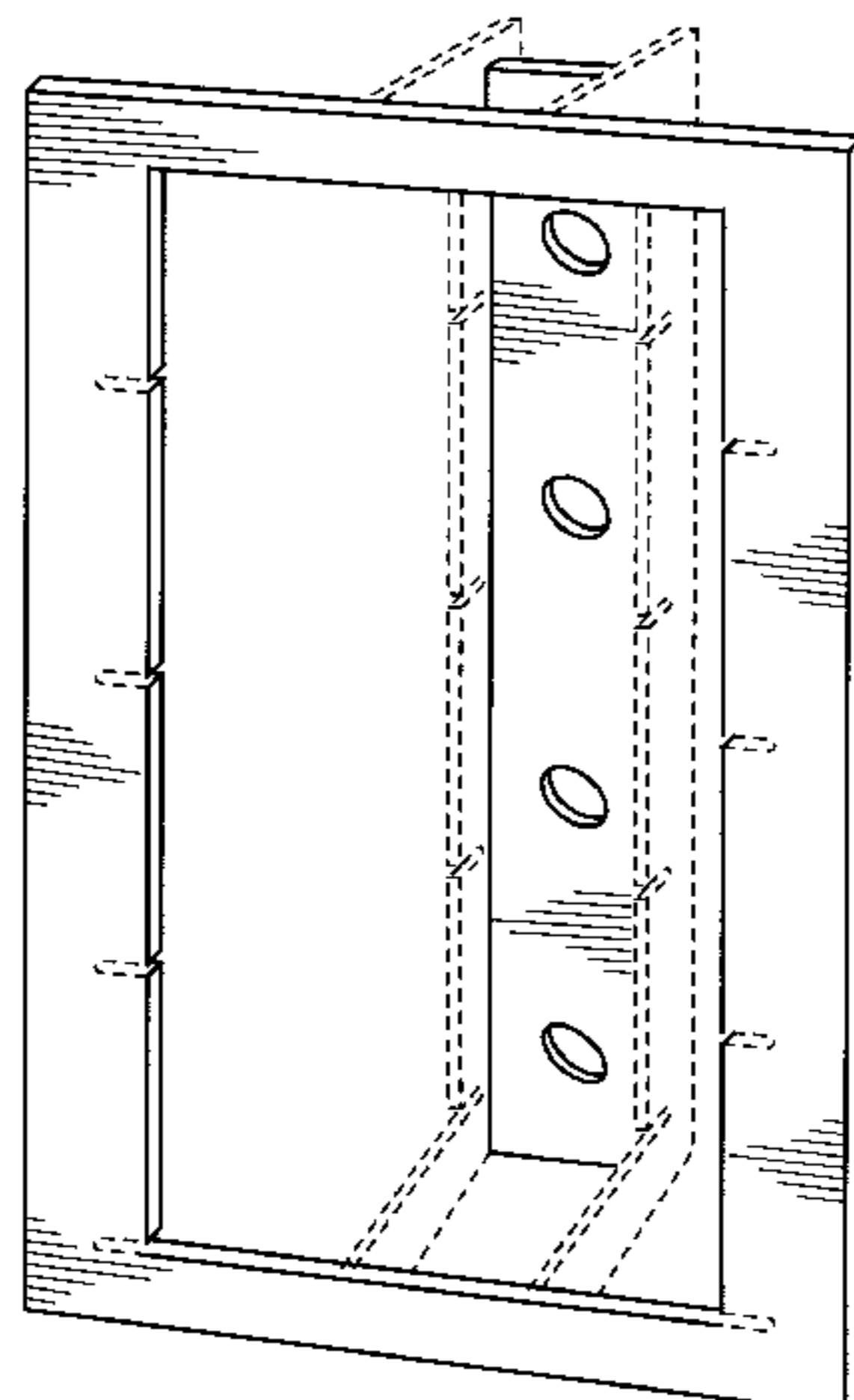

FIG. 11 is a top view of the three embodiments of my design shown in FIGS. 1-10; and,

FIG. 12 is a bottom view of the three embodiments of my design shown in FIGS. 1-10.

The broken lines in FIGS. 1-12 are not part of the claimed design. The broken lines in FIG. 7 extending between the claimed front frame portion and the claimed rear frame portion comprise unclaimed left and right C-shaped frame members. The unclaimed left C-shaped frame member is not shown in FIGS. 3, 6 and 10 so as not to obscure any portion of the claimed design, and the unclaimed left and right

C-shaped frame members are not shown in FIGS. 1-2, 4-5, 8-9, and 11-12 so as not to obscure any portion of the claimed design.

The openings and flat surfaces depicted by the shading in FIG. 7 are consistent among the remaining figures and are not effected by variations in embodiments. The claimed front frame surface in each embodiment continues up to, but does not include, the broken line notches shown therein.

1 Claim, 8 Drawing Sheets

FIG. 1

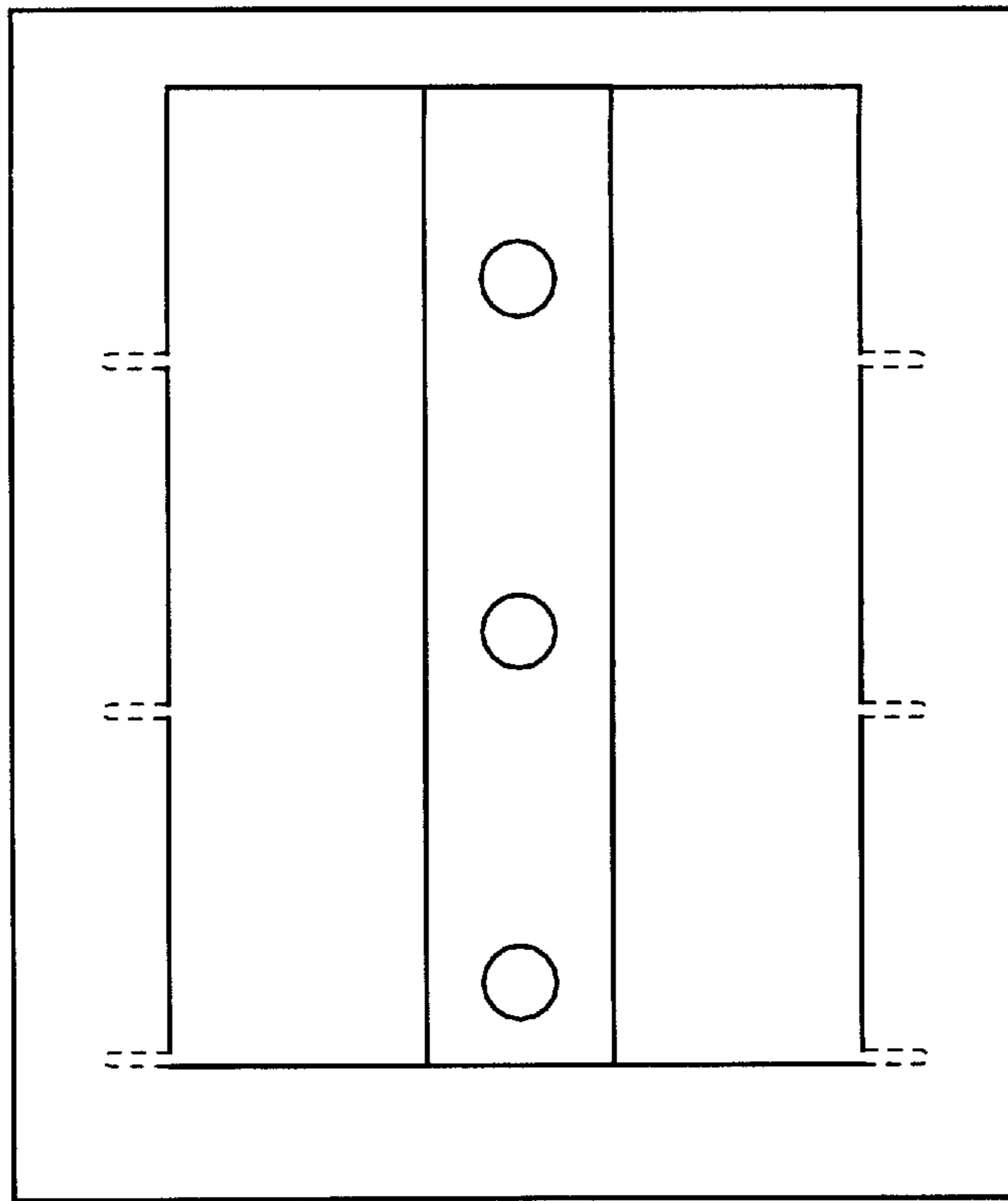

FIG. 2

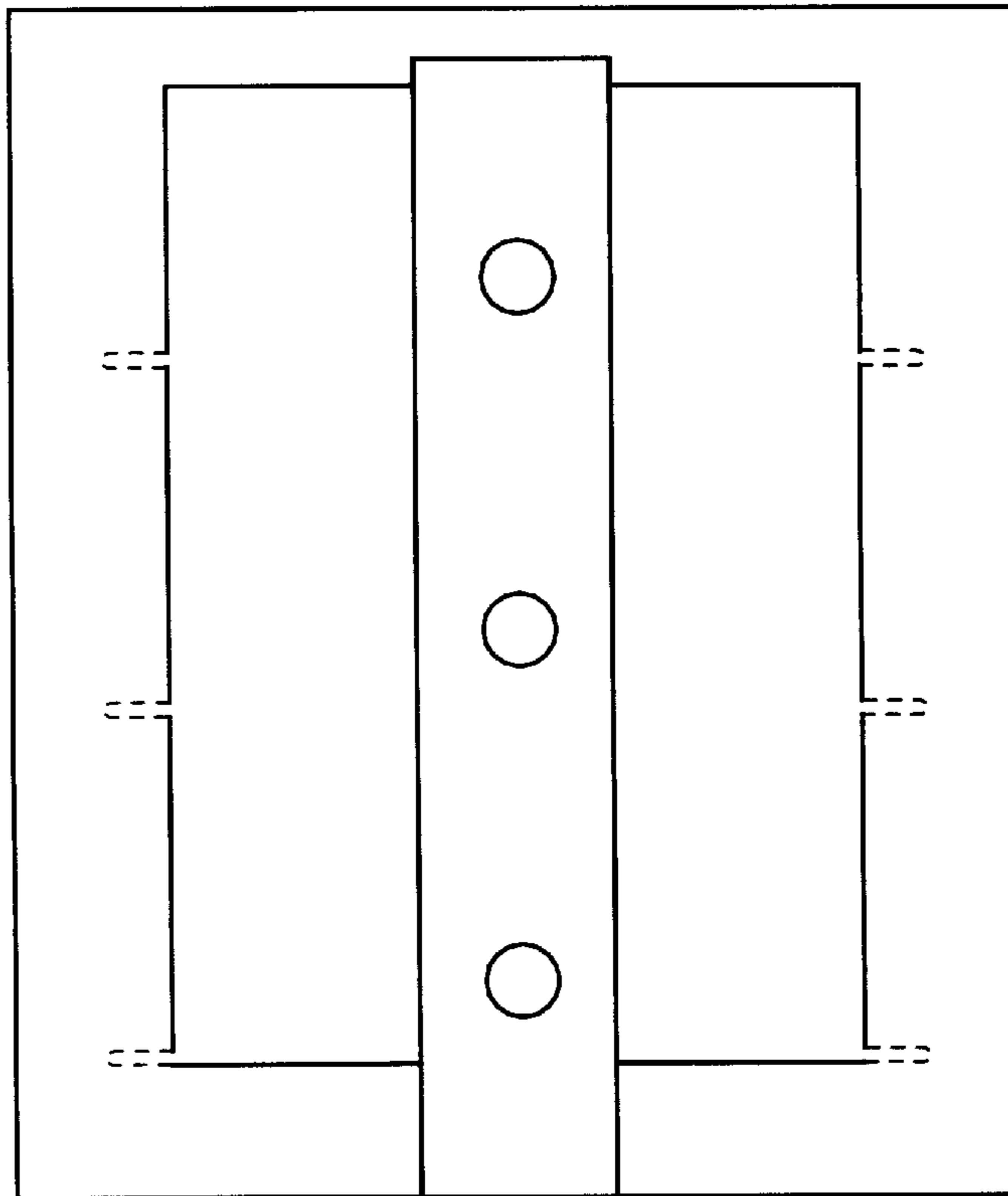

FIG. 3

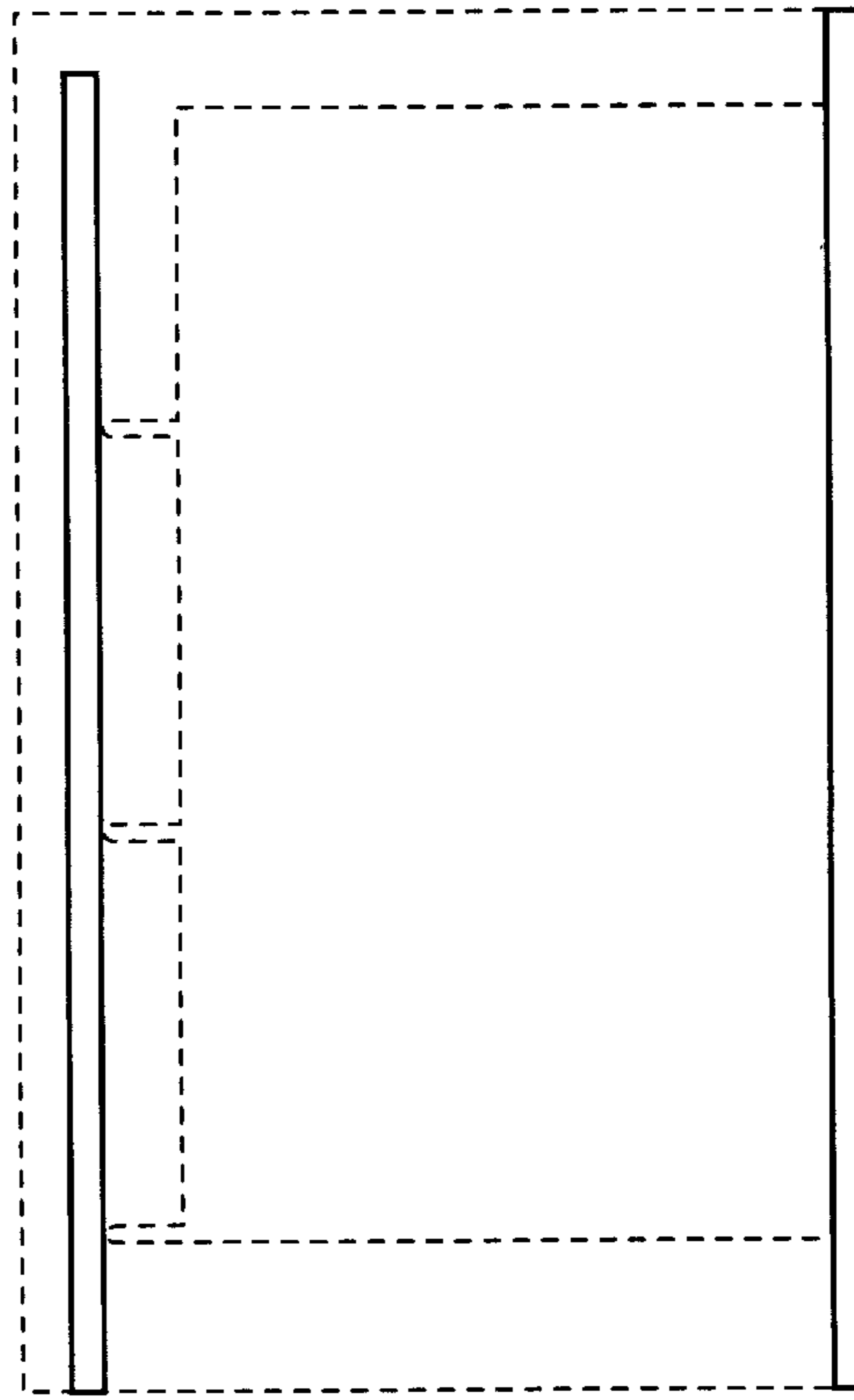

FIG. 4

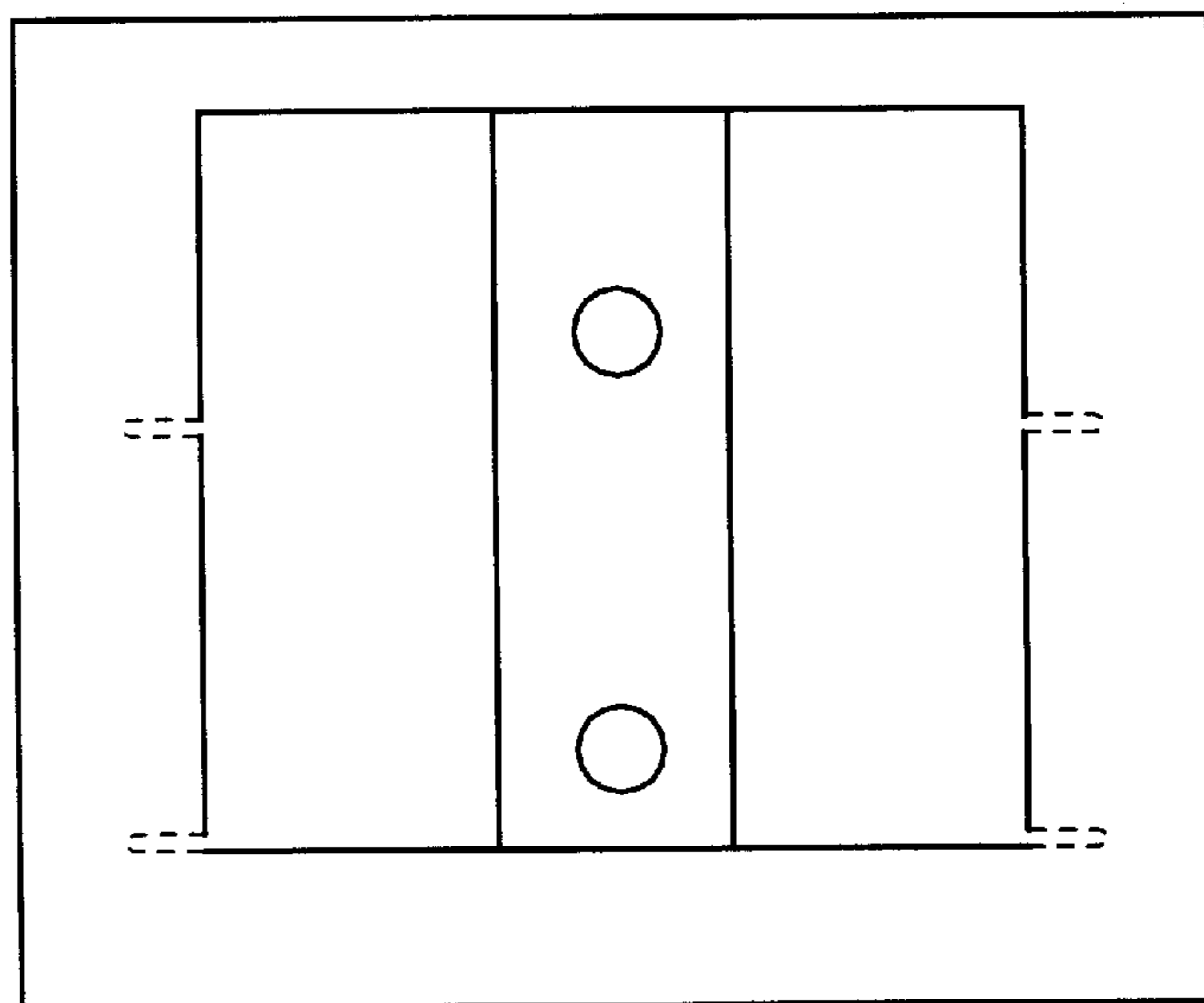

FIG. 5

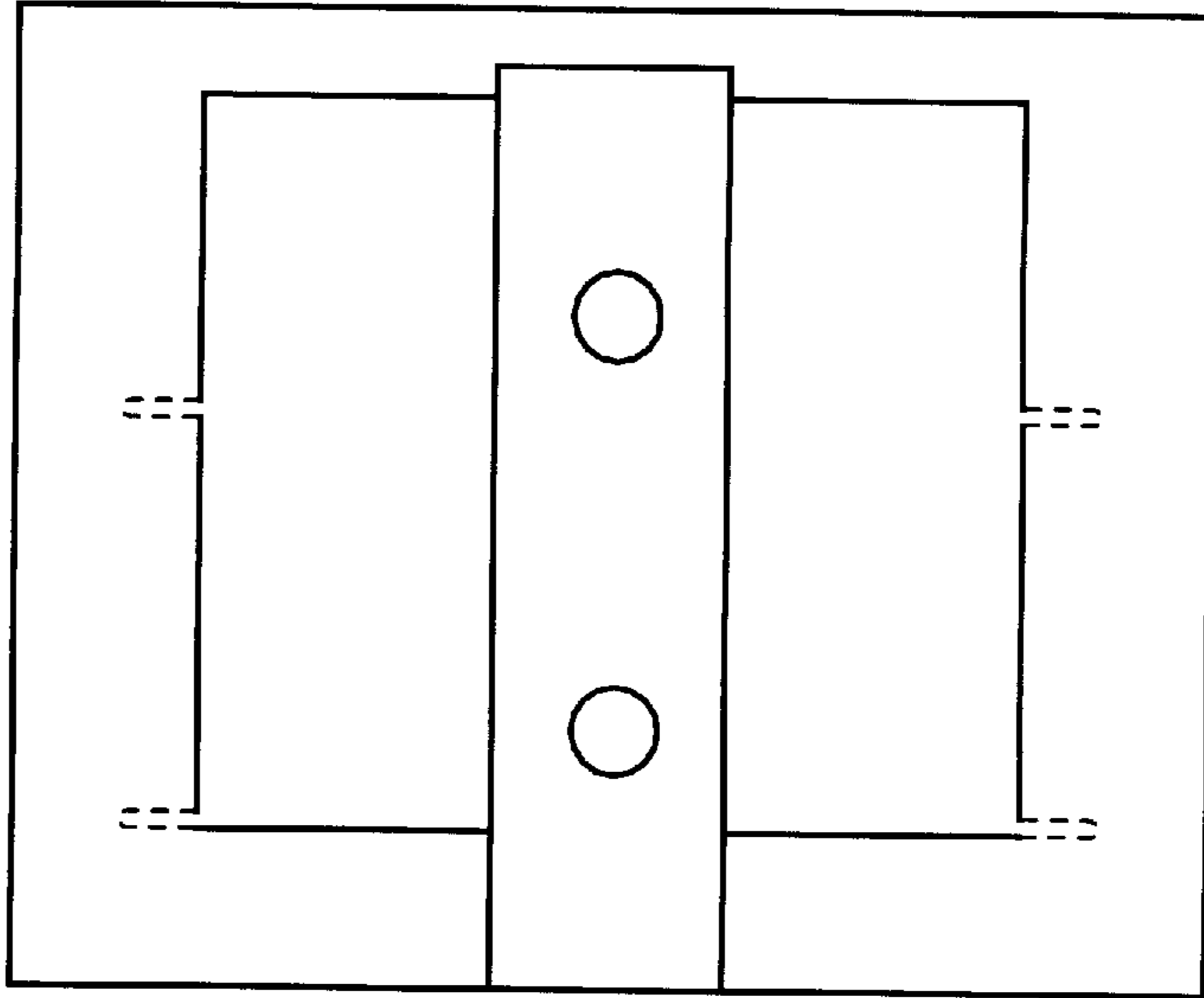
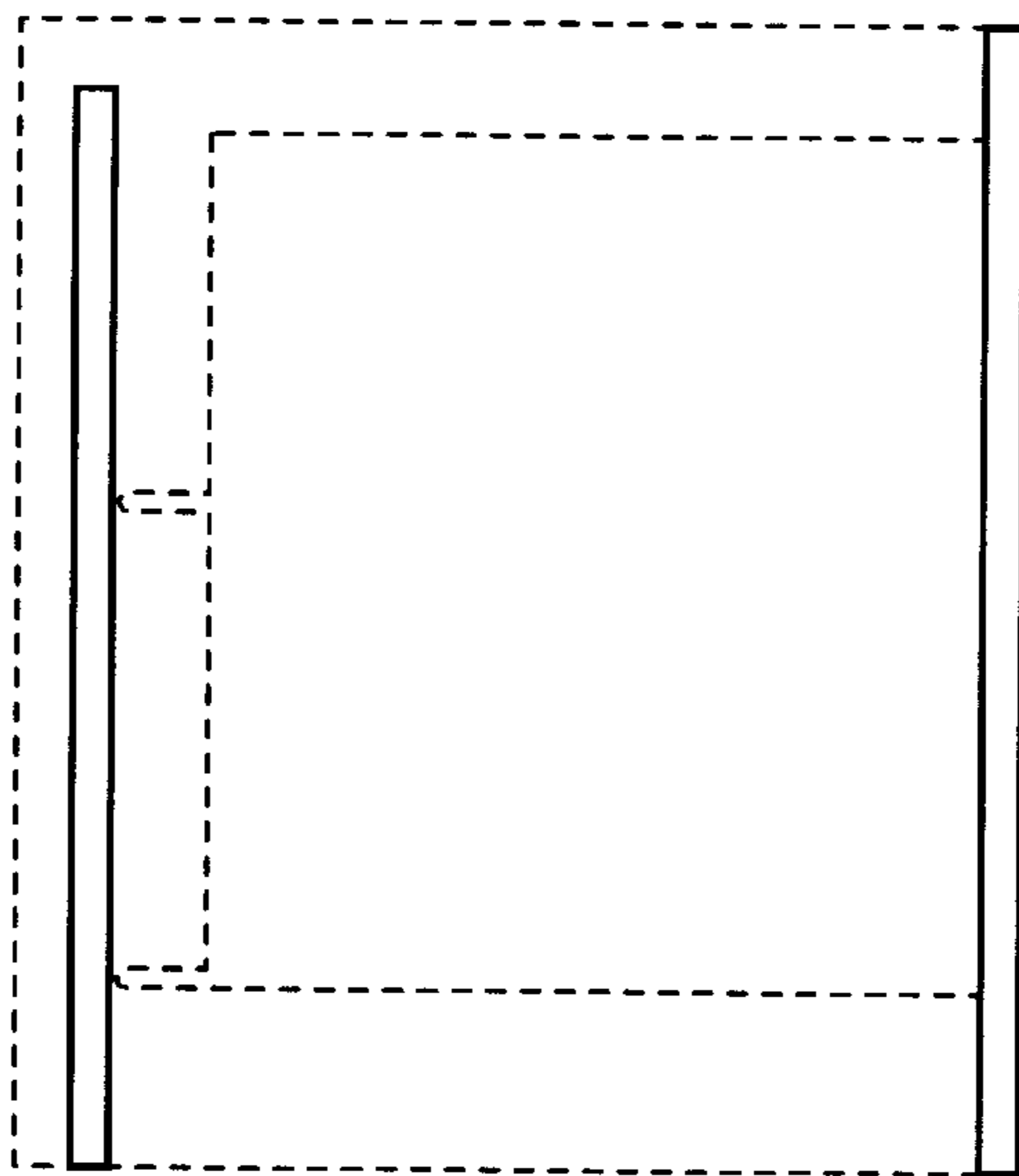

FIG. 6



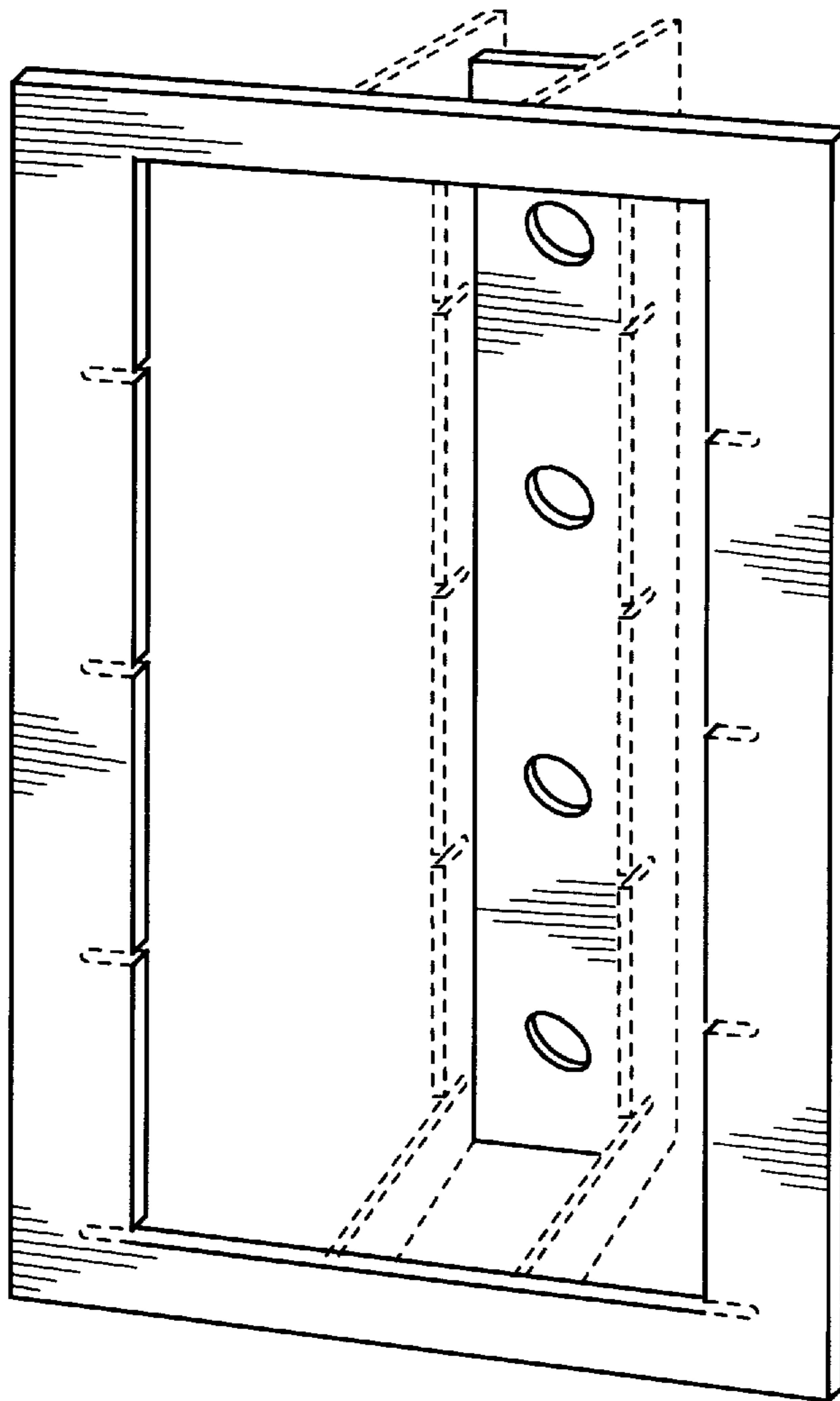

FIG. 7

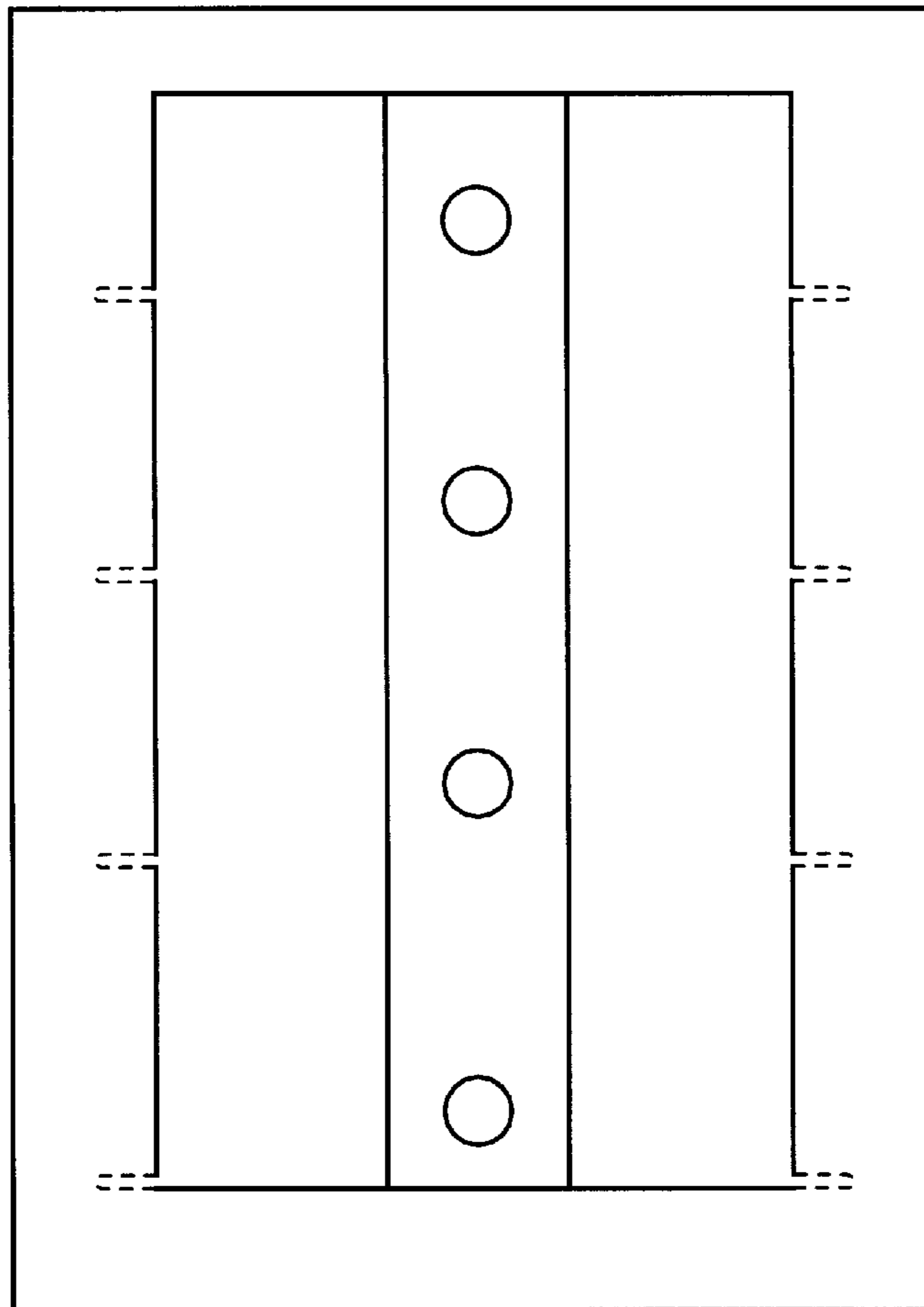

FIG. 8

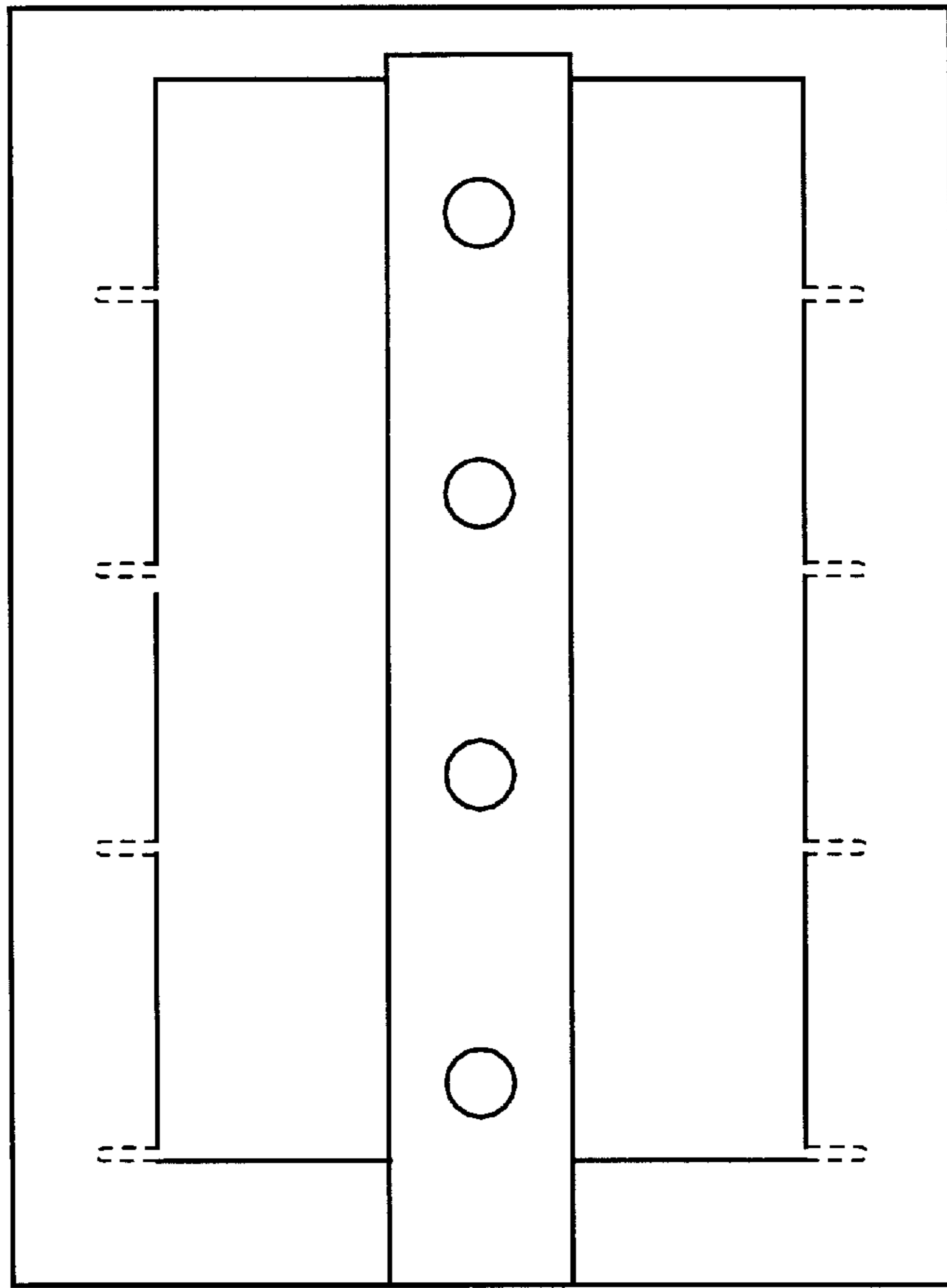

FIG. 9

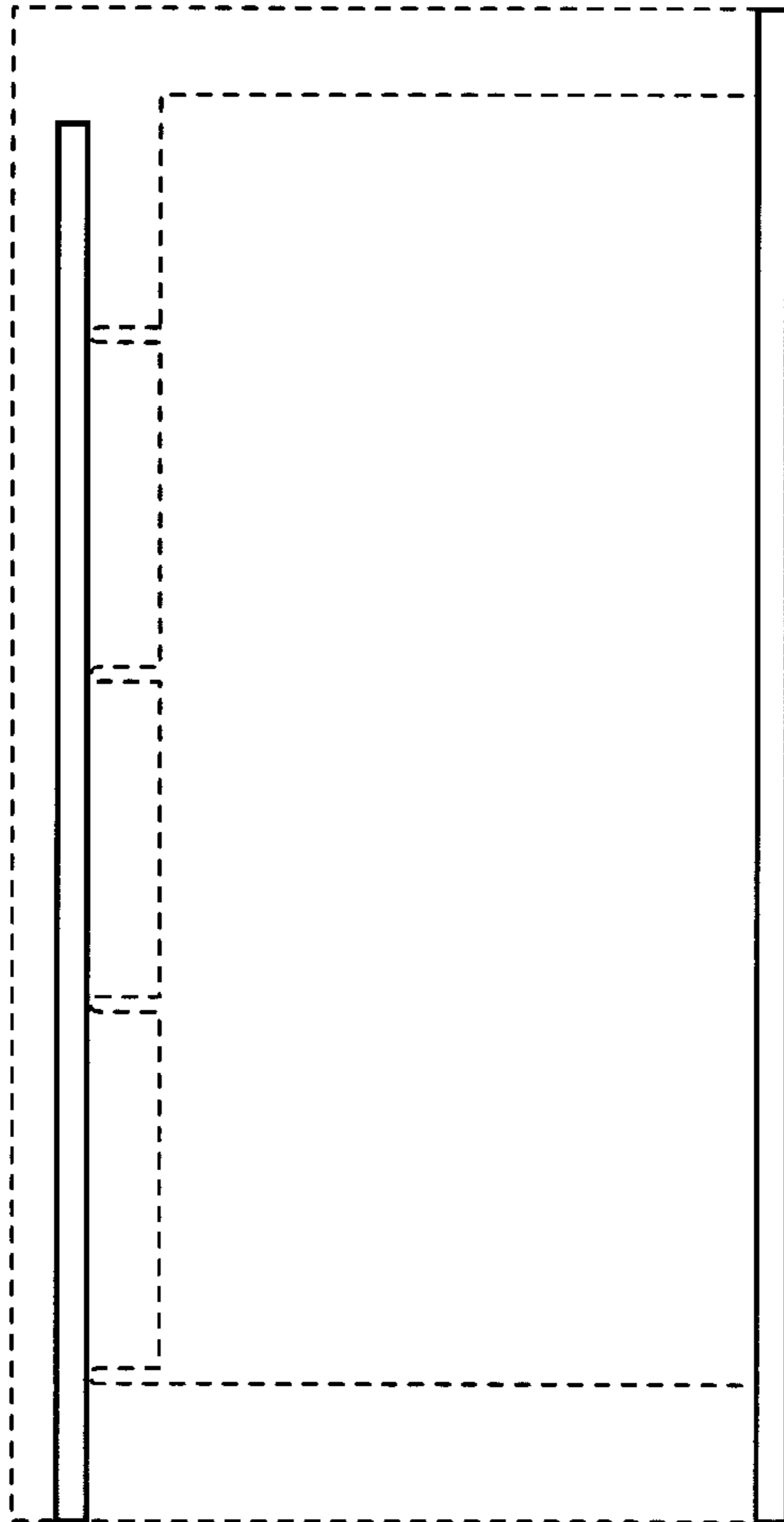

FIG. 10

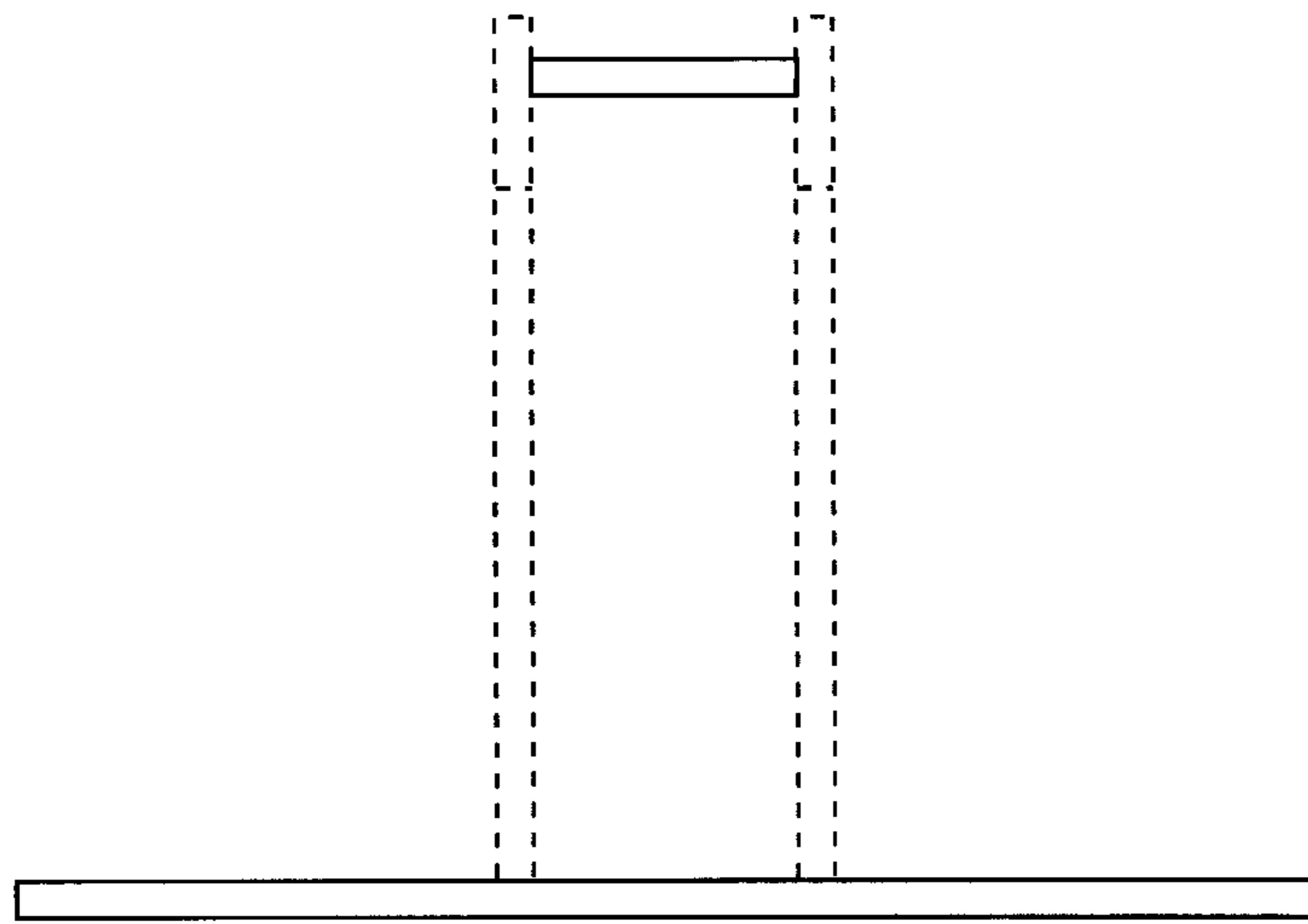

FIG. 11

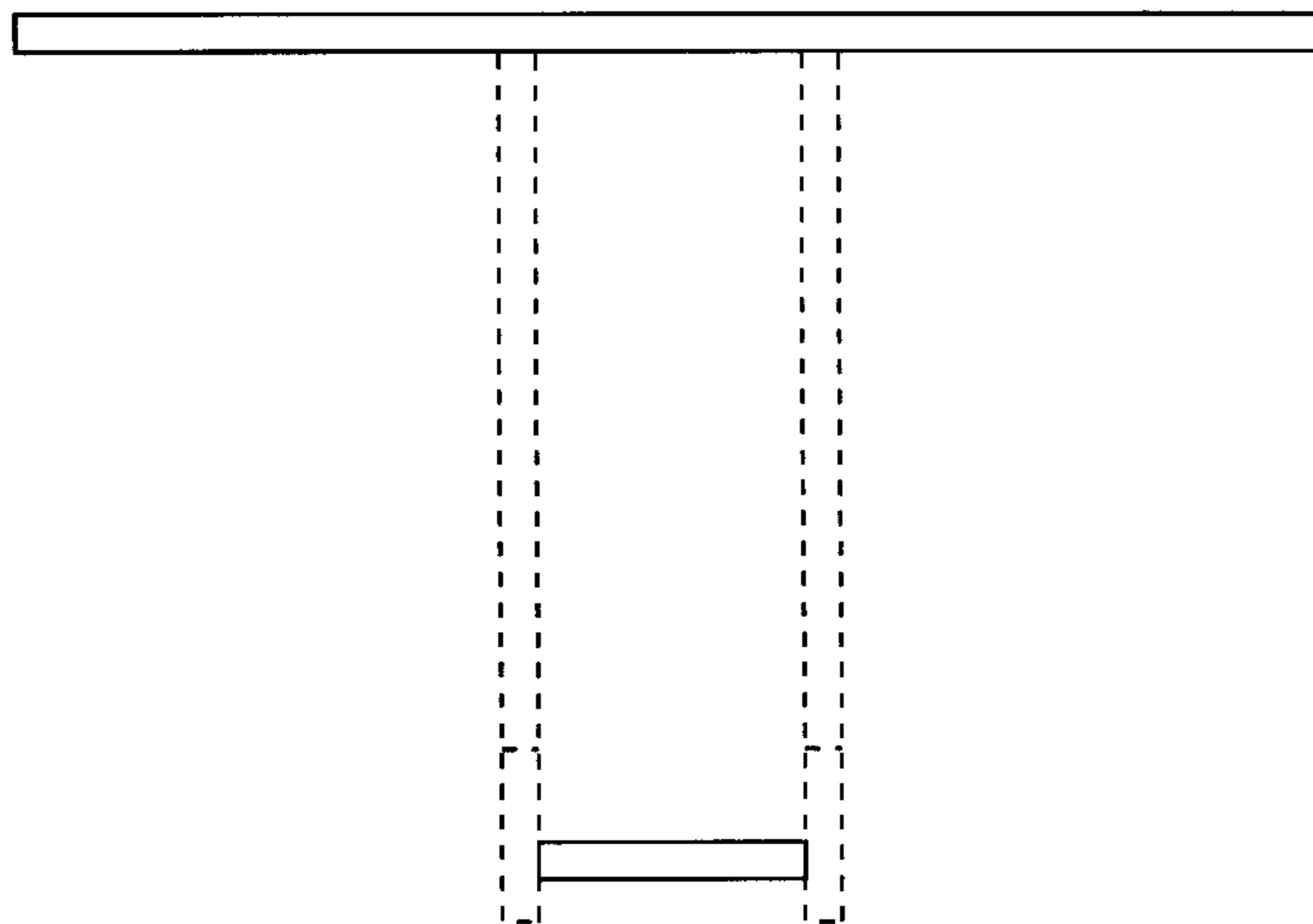

FIG. 12