

US00D404633S

United States Patent [19]
Rivera

[11] **Patent Number: Des. 404,633**

[45] **Date of Patent: **Jan. 26, 1999**

[54] **KNIFE BLADE**

5,511,310 4/1996 Sessions et al. 30/161
5,537,750 7/1996 Seber et al. 30/161

[75] Inventor: **Benjamin C. Rivera**, West Linn, Oreg.

OTHER PUBLICATIONS

[73] Assignee: **Leatherman Tool Group, Inc.**,
Portland, Oreg.

SOG, Auto-Clip folding knife, prior to Jun. 1997.
Hoppes, Division of Penguin Industries, Coatesville, PA,
folding knife with hex wrenches, prior to Jun. 1997.

[**] Term: **14 Years**

Primary Examiner—Philip S. Hyder
Attorney, Agent, or Firm—Chernoff, Vilhauer, McClung &
Stenzel

[21] Appl. No.: **79,217**

[22] Filed: **Oct. 30, 1997**

[51] **LOC (6) Cl.** **08-03**

[52] **U.S. Cl.** **D8/99; D8/98**

[58] **Field of Search** D8/98, 99, 20;
D22/118; 30/151, 152, 153, 154, 155, 156,
157, 158, 159, 160, 161, 162

[57] **CLAIM**

The ornamental design for a knife blade, as shown and described.

DESCRIPTION

FIG. 1 is a side elevational view of a knife blade, showing my new design;
FIG. 2 is a perspective view thereof;
FIG. 3 is a top plan view showing the back thereof;
FIG. 4 is a bottom plan view showing the edge thereof;
FIG. 5 is a left, or tang, end view thereof;
FIG. 6 is a section view thereof, taken along line 6—6; and,
FIG. 7 is a right, or point, end view thereof.

[56] **References Cited**

U.S. PATENT DOCUMENTS

D. 280,179	8/1985	Miceli	D8/99
D. 304,154	10/1989	Osterhout	D8/99
D. 344,006	2/1994	Glesser	D8/99
2,869,232	1/1959	Kivela	30/161
4,347,665	9/1982	Glesser	30/161
4,555,822	12/1985	Miceli	7/119
5,111,581	5/1992	Collins	30/161

1 Claim, 2 Drawing Sheets

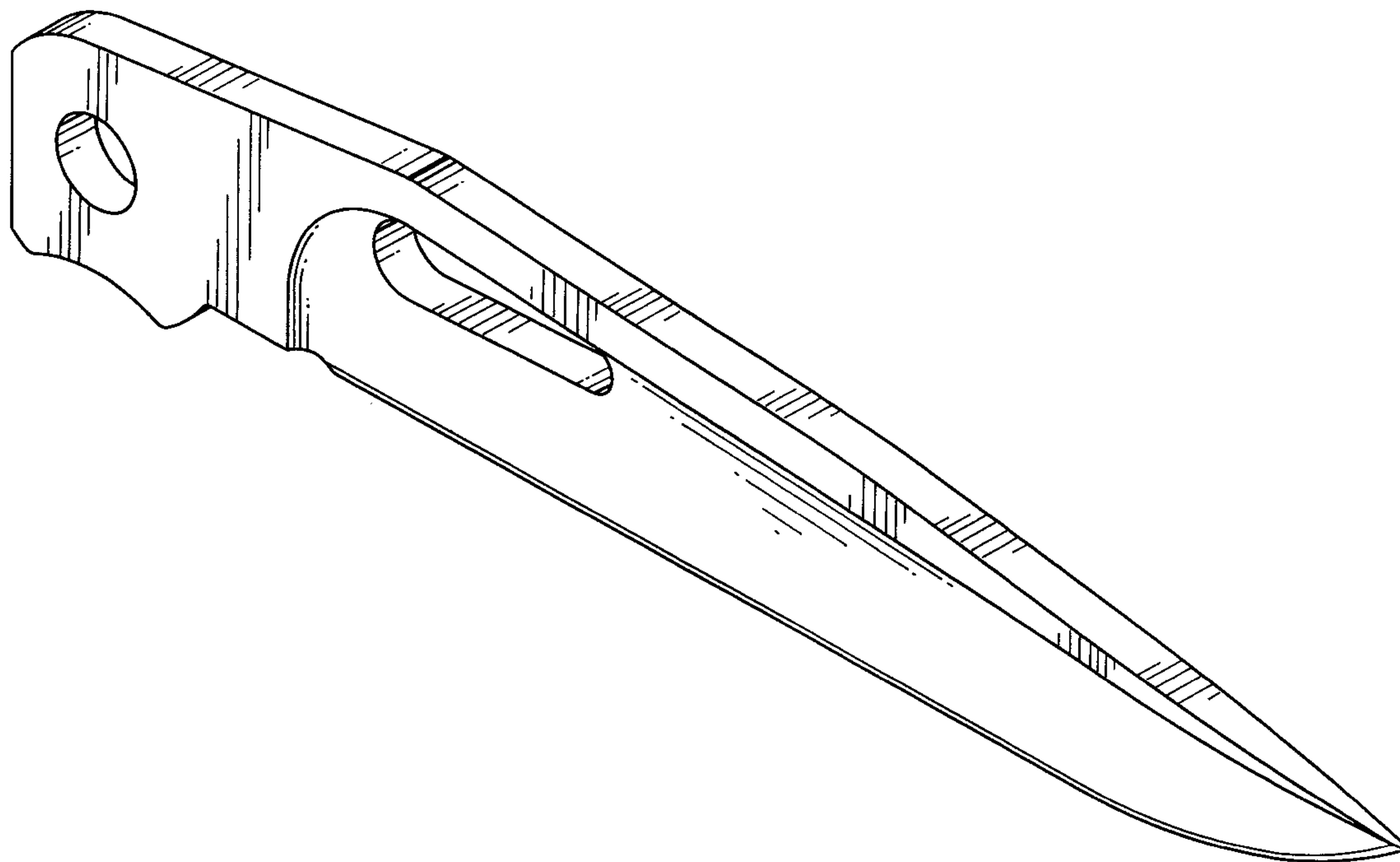

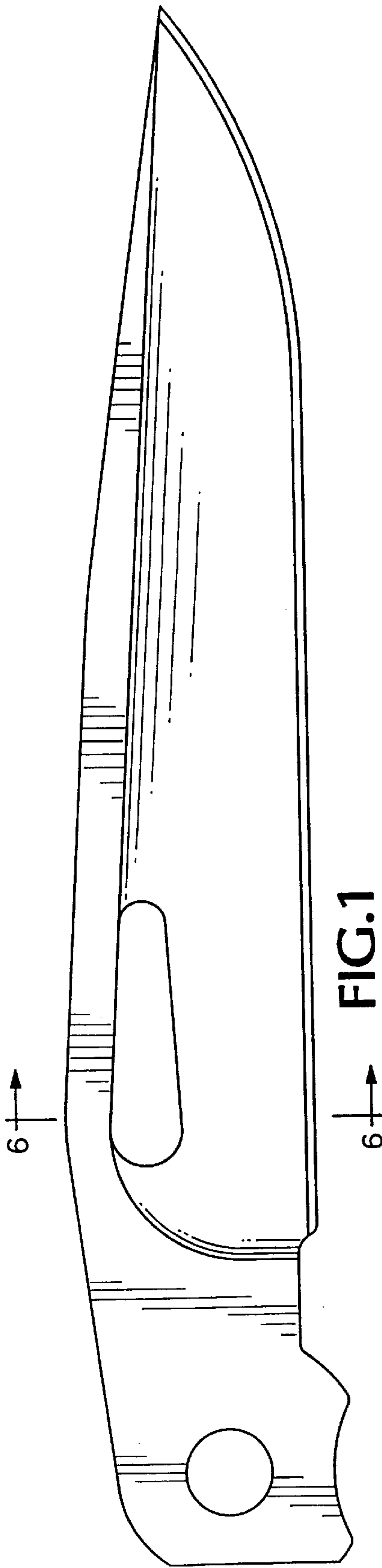

FIG. 6

FIG. 7

FIG. 5

FIG. 3

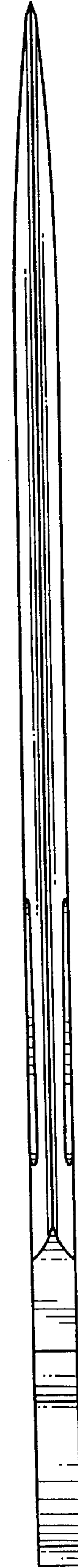
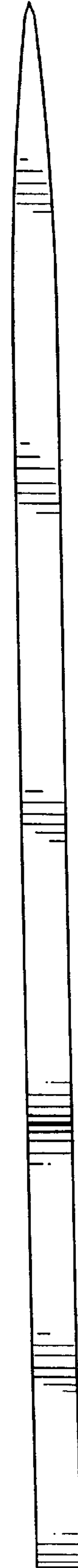

FIG. 4

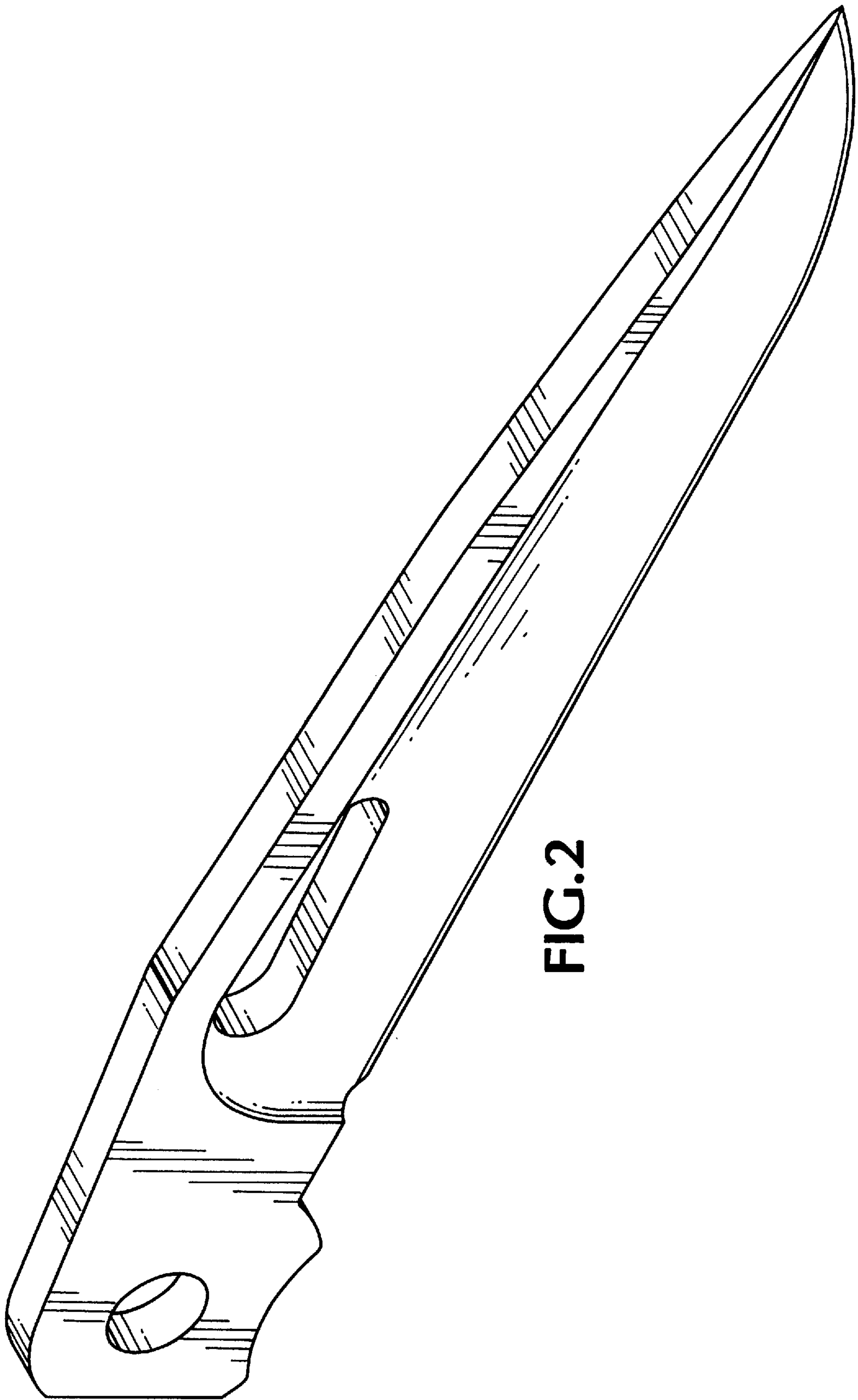

FIG. 2