



US00D404489S

# United States Patent [19]

[11] Patent Number: Des. 404,489

Kellstedt, Jr. et al.

[45] Date of Patent: \*\*Jan. 19, 1999

[54] NON-INVASIVE BLOOD SENSING DEVICE

[75] Inventors: Charles W. Kellstedt, Jr.; Joel M. Lieblein, both of Sudbury, Mass.; John R. Maliszewski, Indiana, Pa.

[73] Assignee: Diasense, Inc., Pittsburgh, Pa.

[\*\*] Term: 14 Years

[21] Appl. No.: 50,719

[22] Filed: Feb. 23, 1996

[51] LOC (6) Cl. .... 24-01

[52] U.S. Cl. .... D24/186

[58] Field of Search ..... D24/231, 232, D24/169, 180; 422/105; 435/287.1; 128/635, 633

### [56] References Cited

#### U.S. PATENT DOCUMENTS

D. 249,892	10/1978	Aul et al. ....	D24/169 X
D. 330,596	10/1992	Frenhel et al. ....	D24/186
D. 338,658	8/1993	Suzuki ....	D24/186 X
D. 351,910	10/1994	Anderson et al. ....	D24/109
D. 358,583	5/1995	Winhler ....	D24/186 X
4,014,321	3/1977	March ....	128/633

Primary Examiner—Stella Reid

Attorney, Agent, or Firm—Webb Ziesenheim Bruening Logsdon Orkin & Hanson, P.C.

### [57] CLAIM

The ornamental design for non-invasive blood sensing device, as shown and described.

### DESCRIPTION

FIG. 1 is a perspective view of the non-invasive blood sensing according to the new design with the video screen in the raised position and the arm support members in the extended position;

FIG. 2 is a front elevation view of the device shown in FIG. 1;

FIG. 3 is a rear elevation view of the device shown in FIG. 1;

FIG. 4 is a top plan view of the device shown in FIG. 1;

FIG. 5 is a bottom plan view of the device shown in FIG. 1;

FIG. 6 is a left side elevation view of the device shown in FIG. 1;

FIG. 7 is a right side elevation view of the device shown in FIG. 1;

FIG. 8 is a perspective view of the non-invasive blood sensing according to the new design with the video screen in the lowered position and the arm support members in the retracted position;

FIG. 9 is a front elevation view of the device shown in FIG. 8;

FIG. 10 is a rear elevation view of the device shown in FIG. 8;

FIG. 11 is a top plan view of the device shown in FIG. 8;

FIG. 12 is a bottom plan view of the device shown in FIG. 8;

FIG. 13 is a left side elevation view of the device shown in FIG. 8;

FIG. 14 is a right side elevation view of the device shown in FIG. 8;

FIG. 15 is a perspective view of the non-invasive blood sensing according to the new design with the video screen in the raised position, the arm support members in the retracted position and the power pack detached;

FIG. 16 is a front elevation view of the device shown in FIG. 15;

FIG. 17 is a rear elevation view of the device shown in FIG. 15;

FIG. 18 is a top plan view of the device shown in FIG. 15;

FIG. 19 is a bottom plan view of the device shown in FIG. 15;

FIG. 20 is a left side elevation view of the device shown in FIG. 15; and,

FIG. 21 is a right side elevation view of the device shown in FIG. 15.

1 Claim, 20 Drawing Sheets

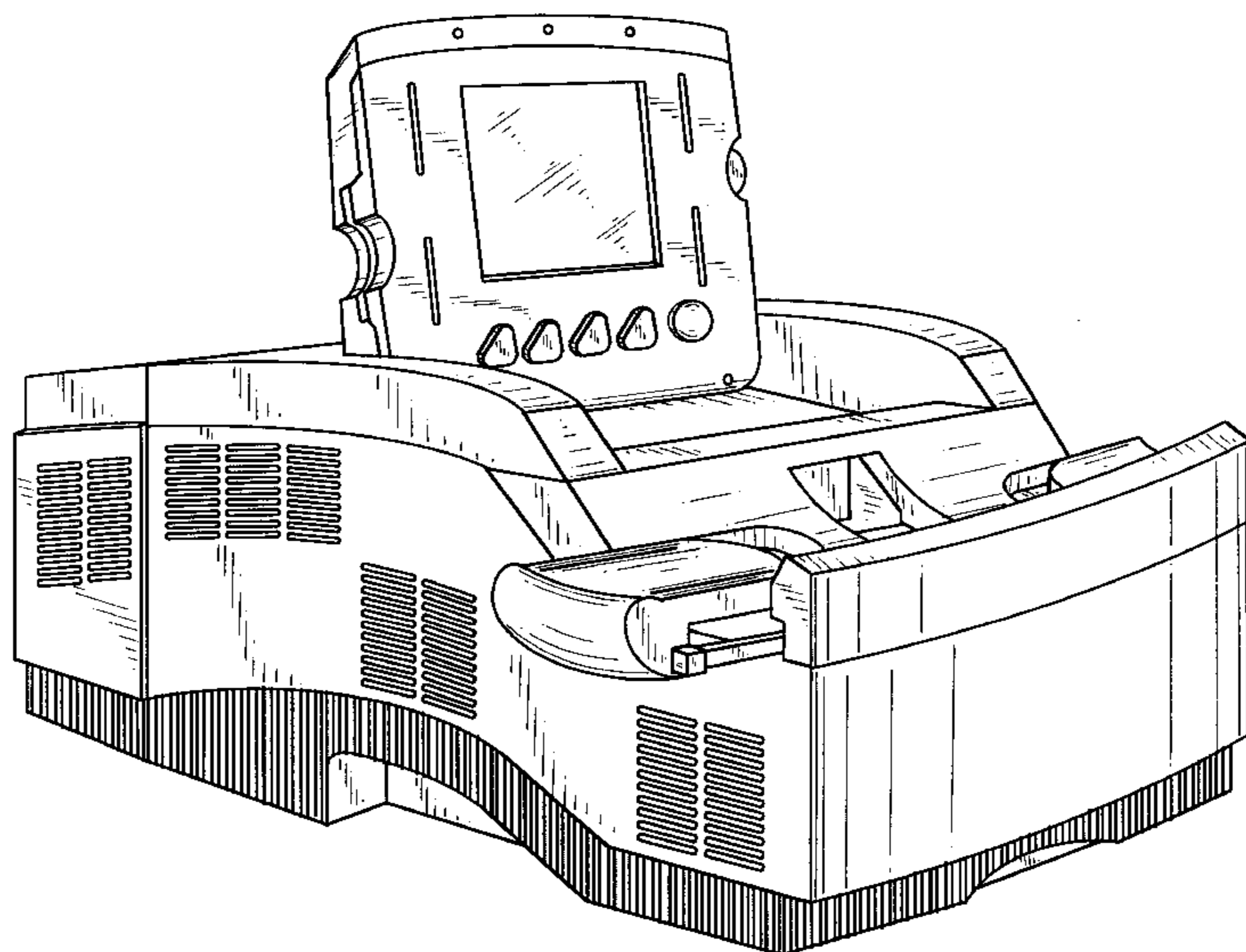

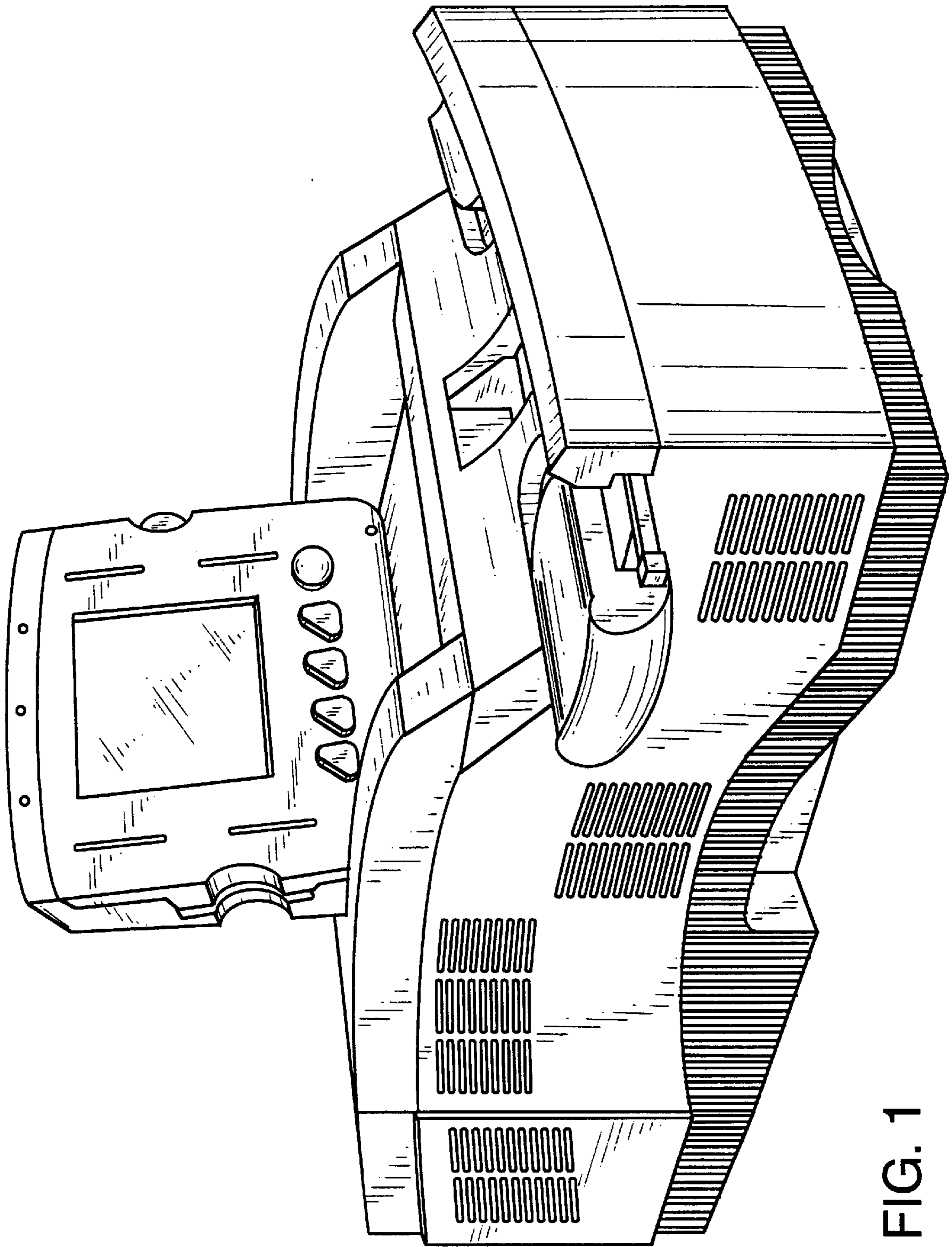

FIG. 1

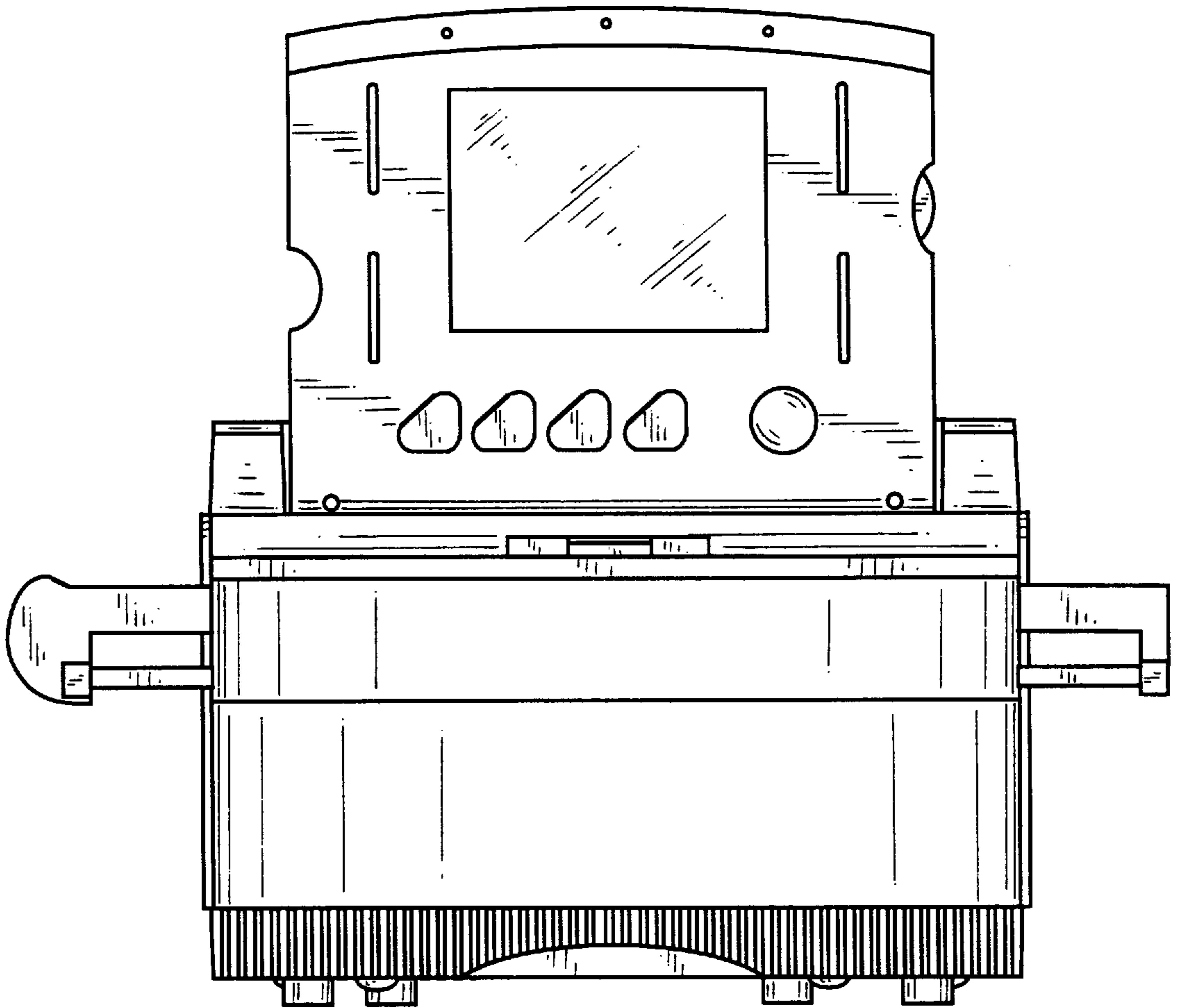

FIG. 2

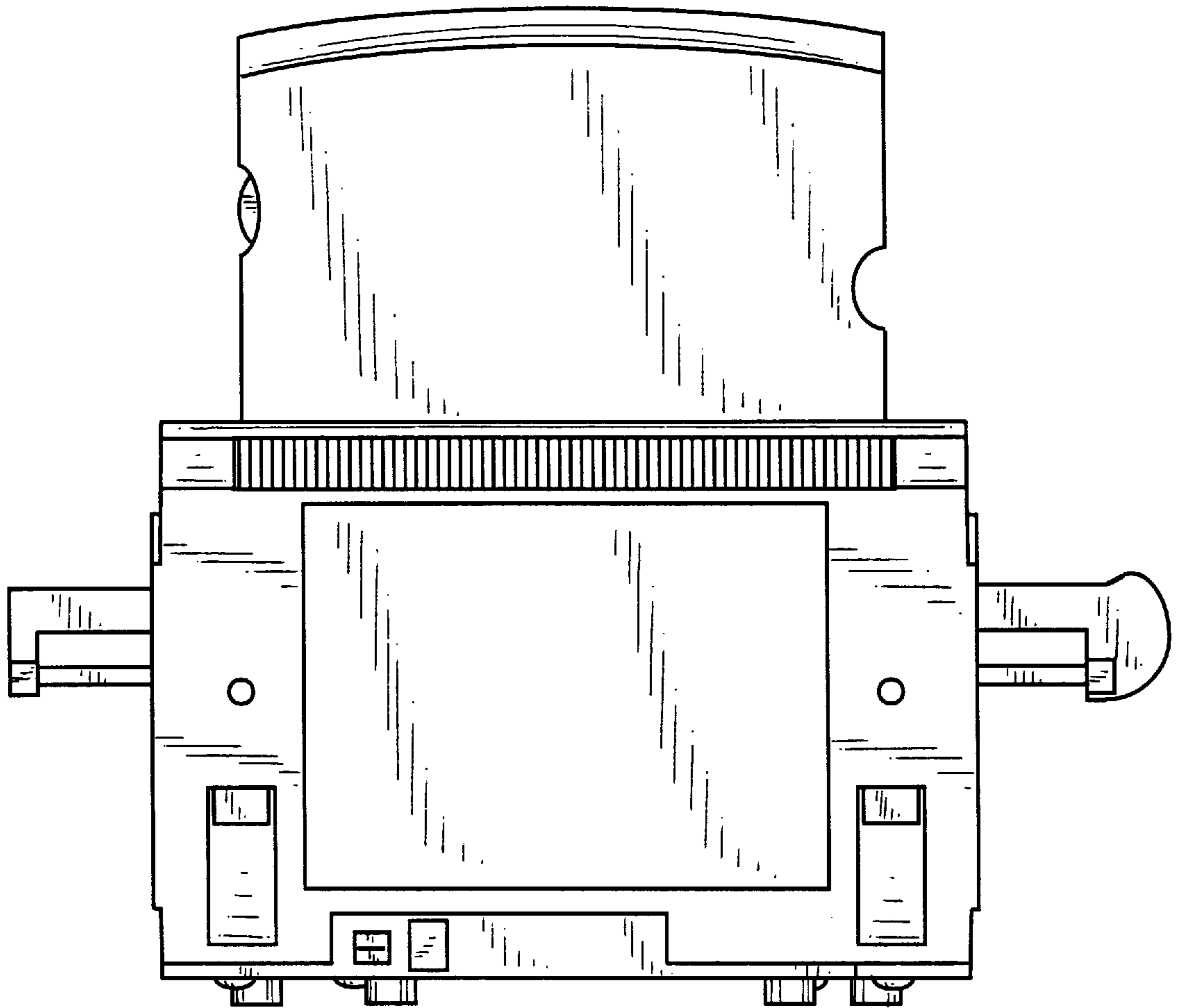

FIG. 3

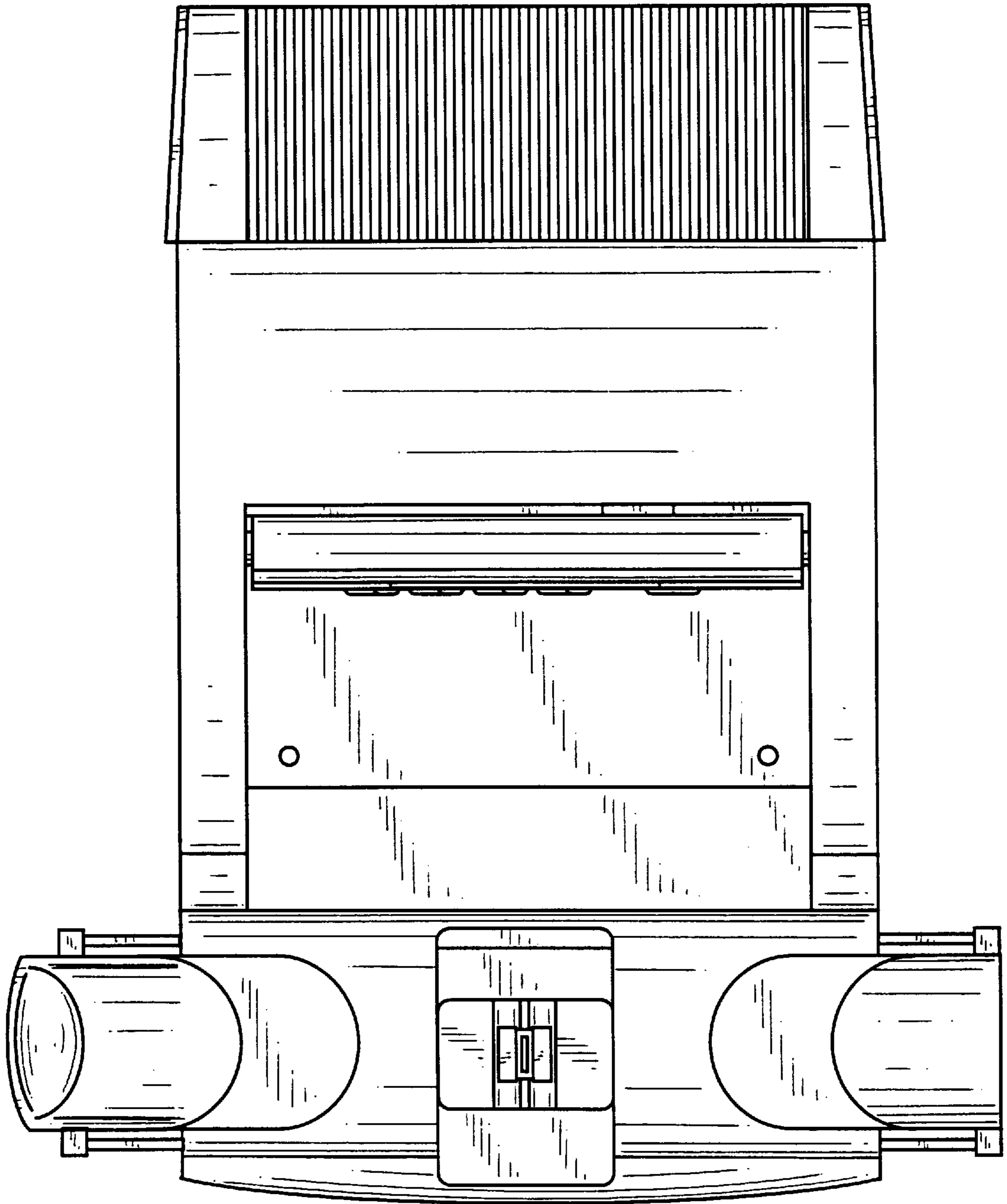

FIG. 4

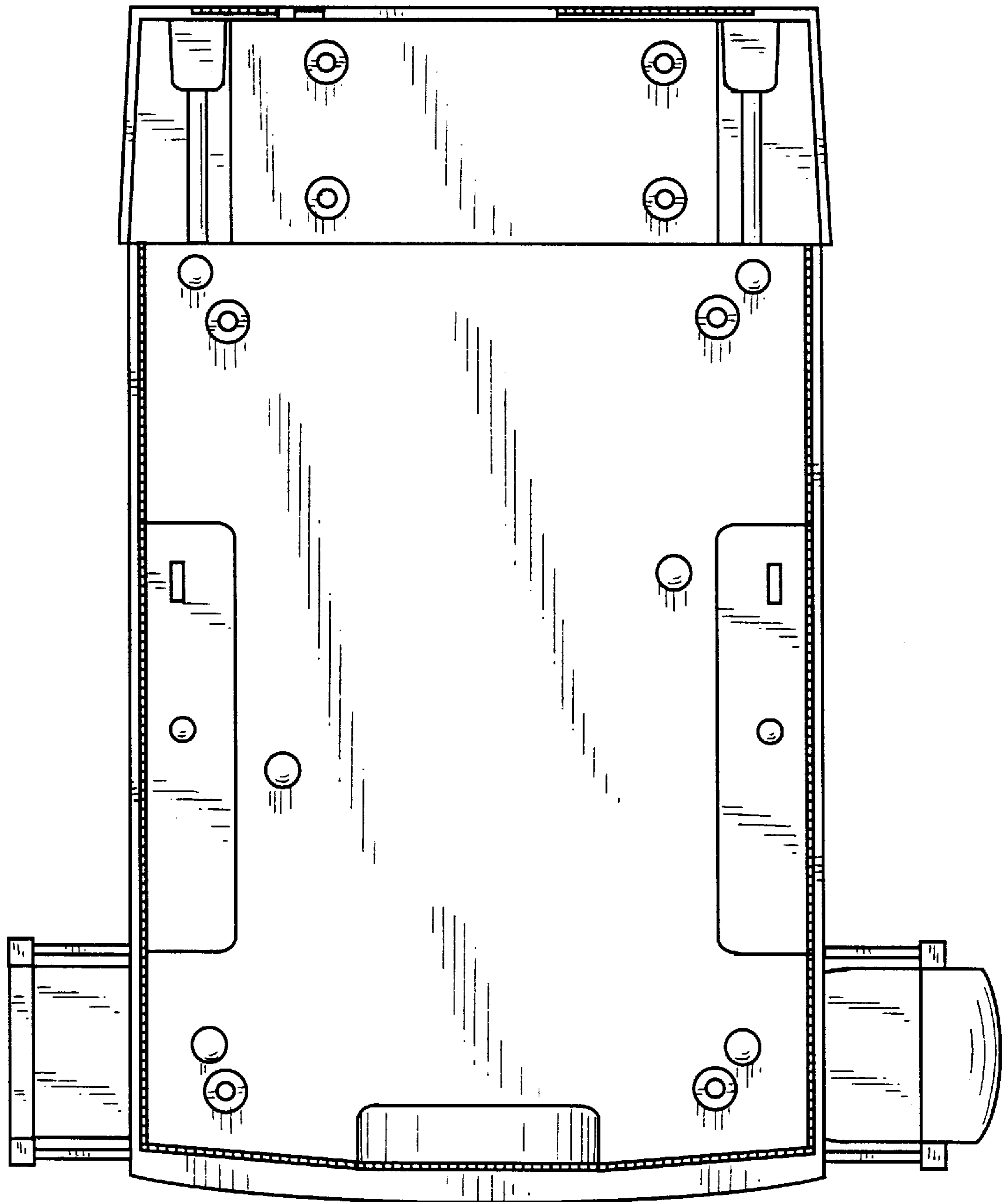

FIG. 5

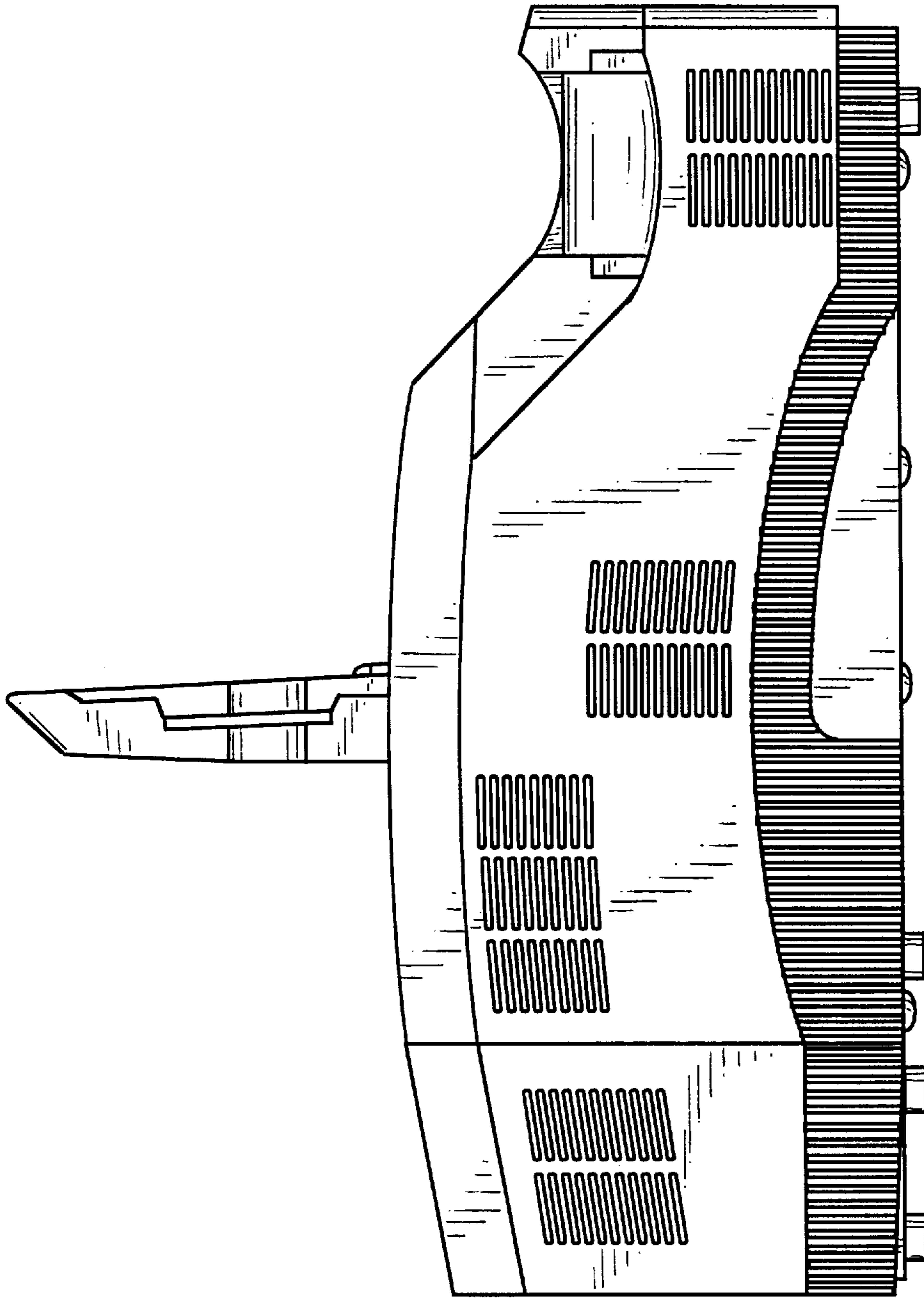

FIG. 6

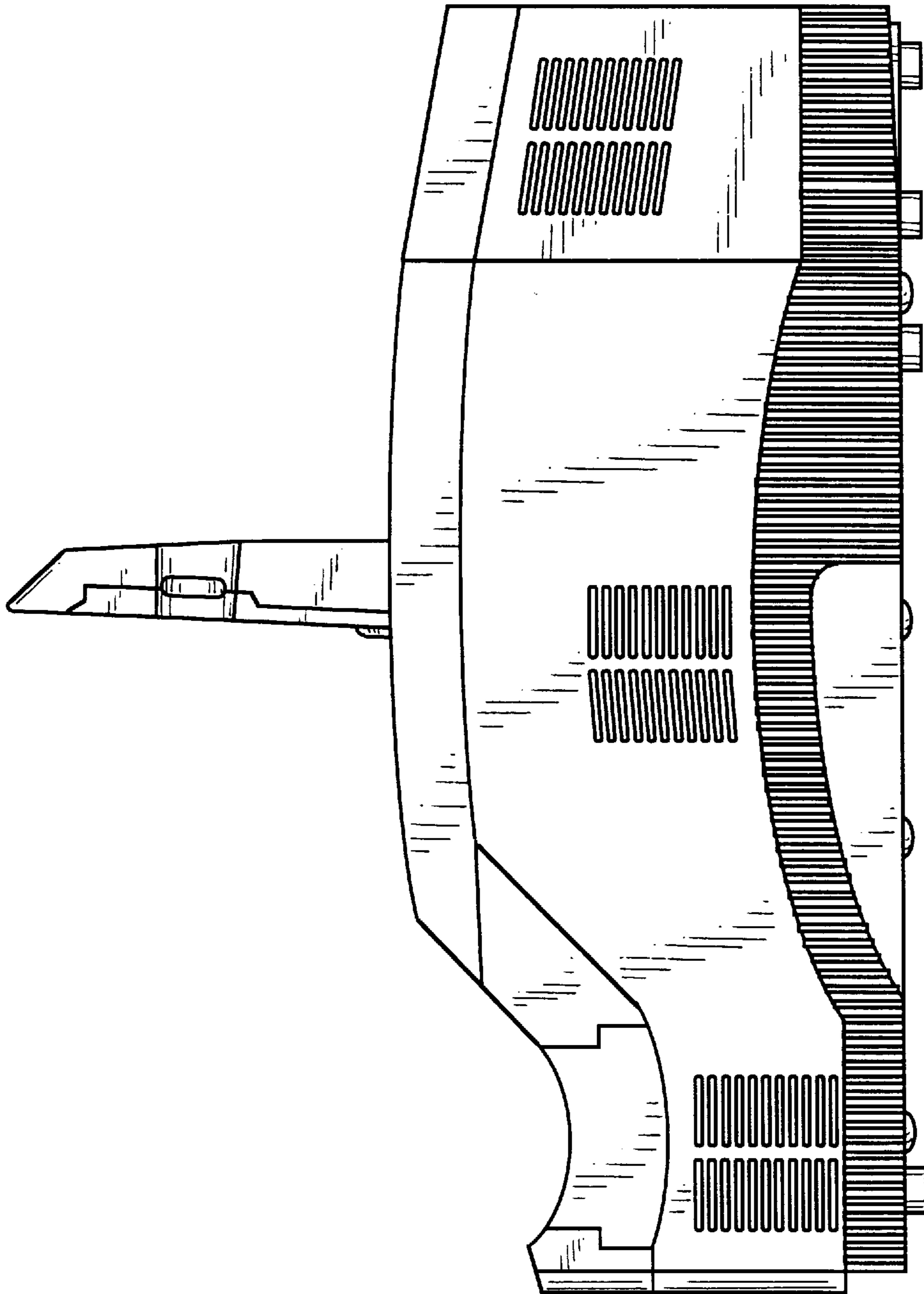

FIG. 7



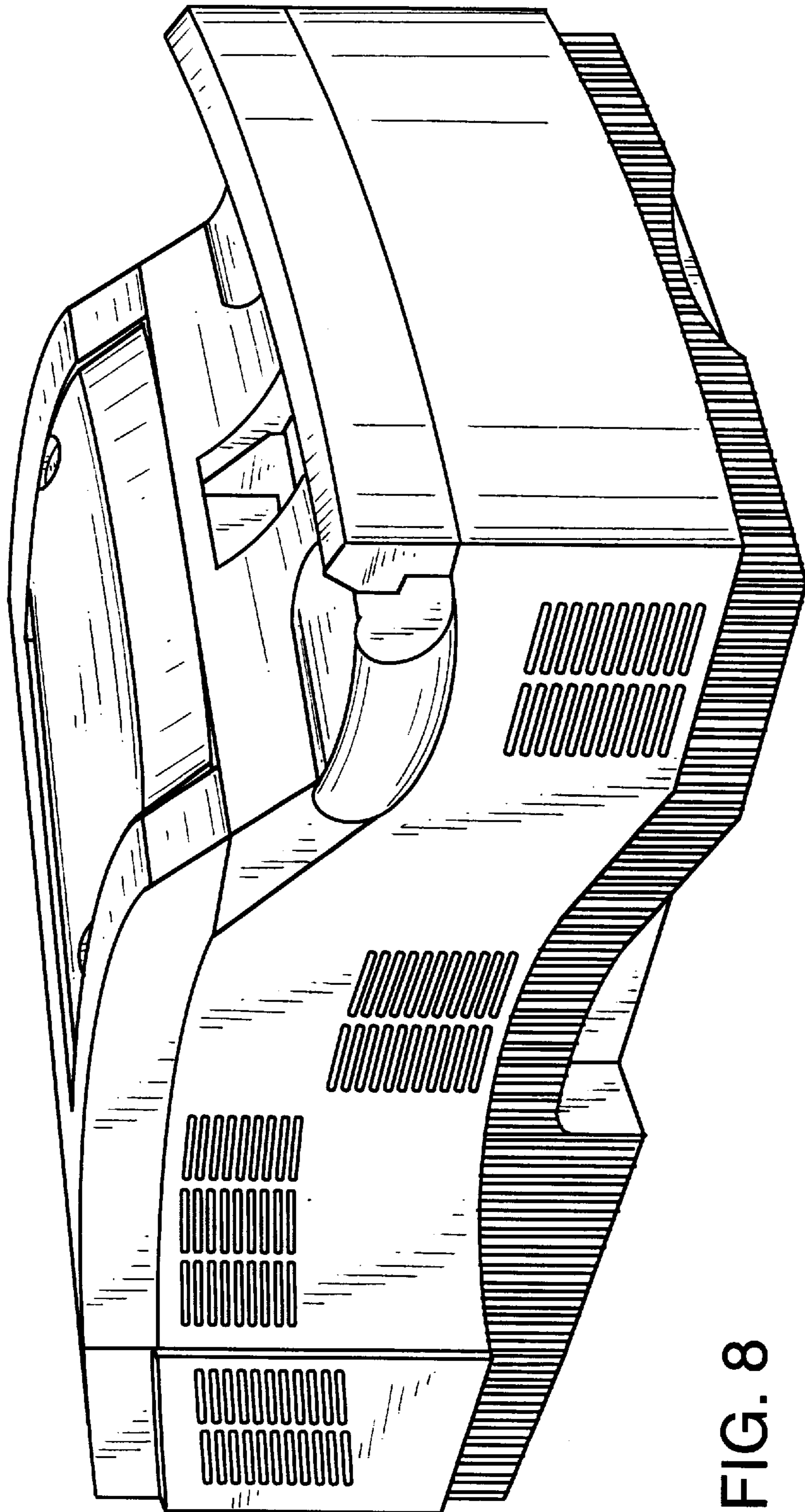

FIG. 8

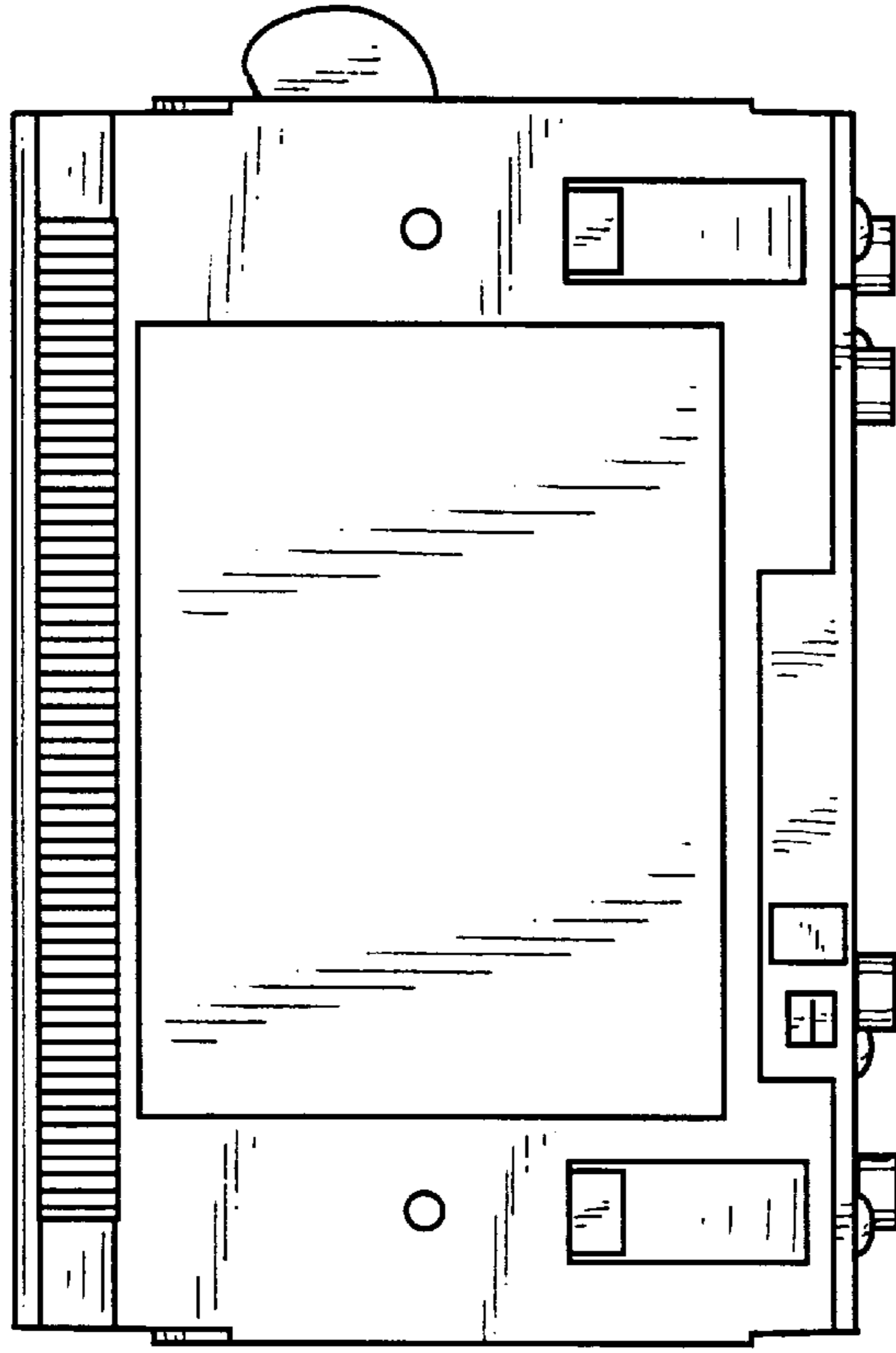

FIG. 10

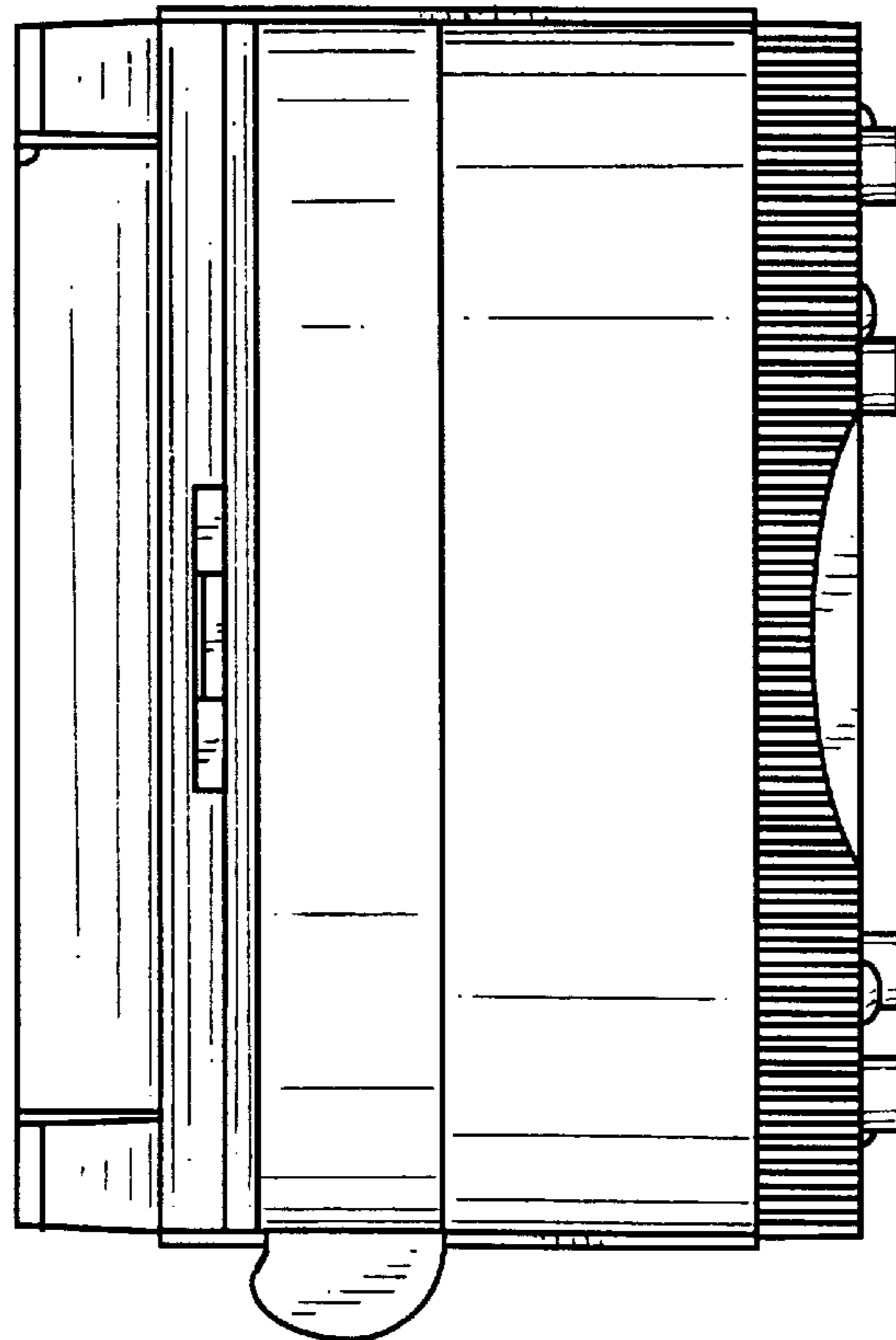

FIG. 9

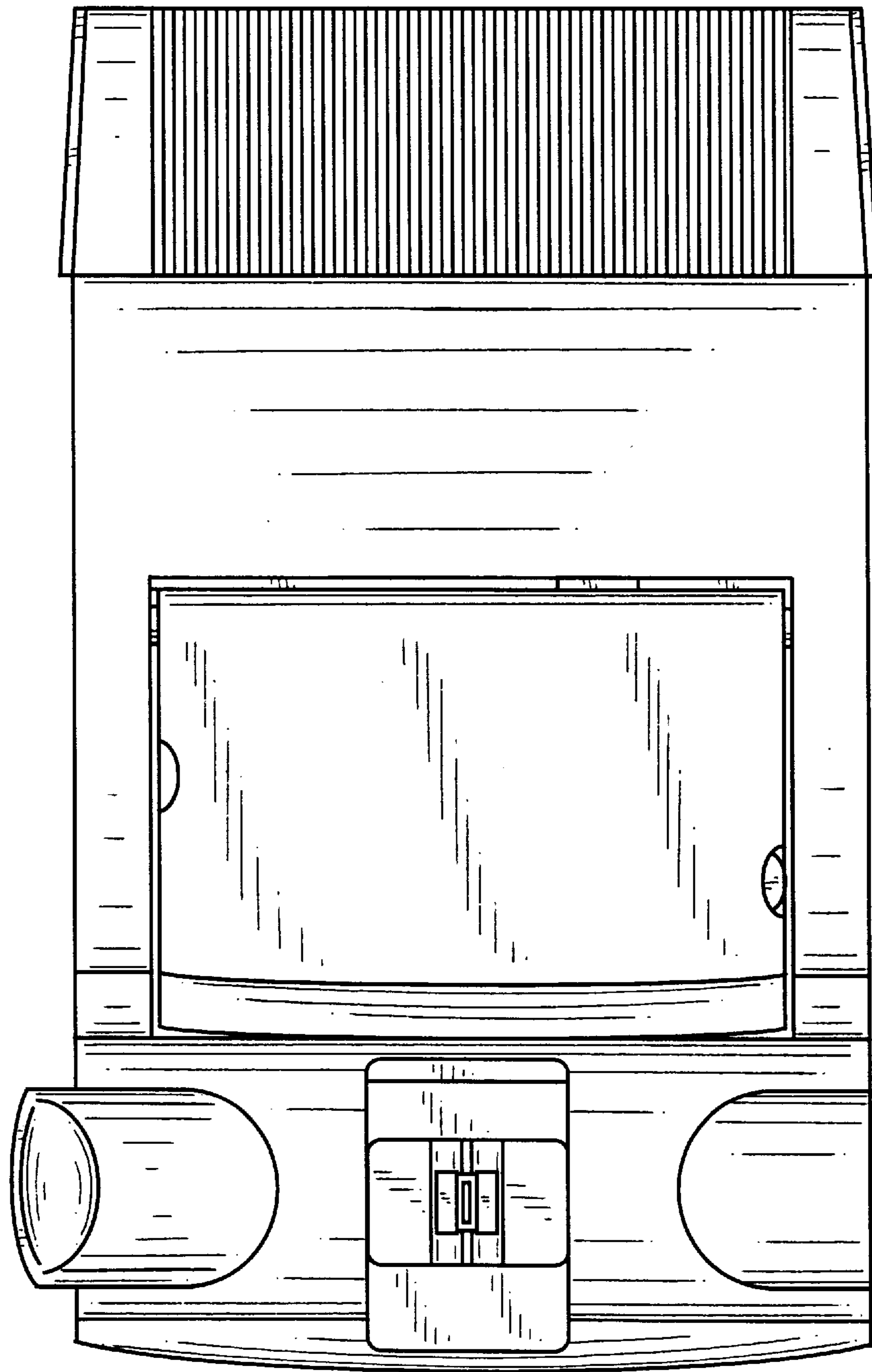

FIG. 11

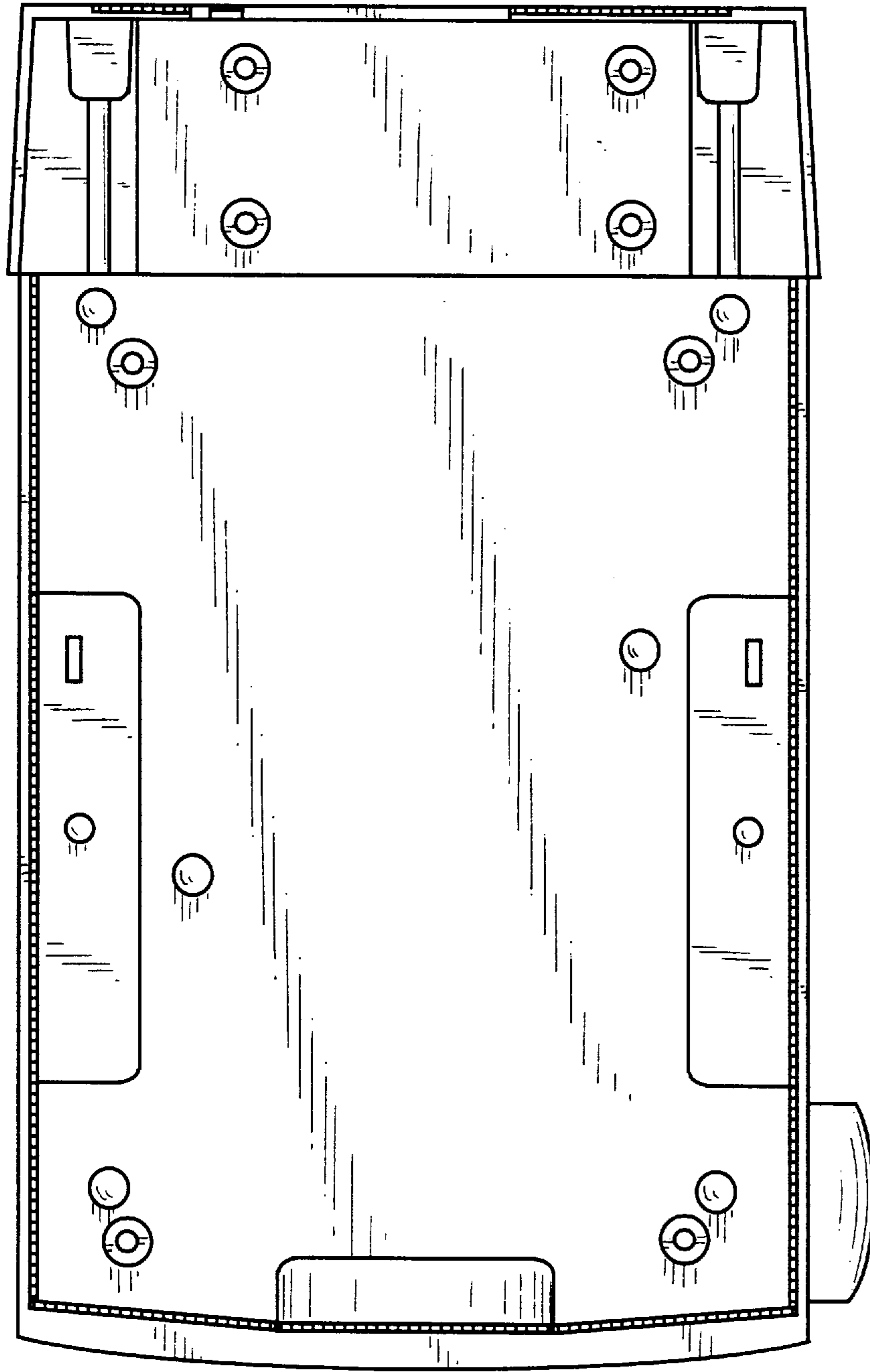

FIG. 12

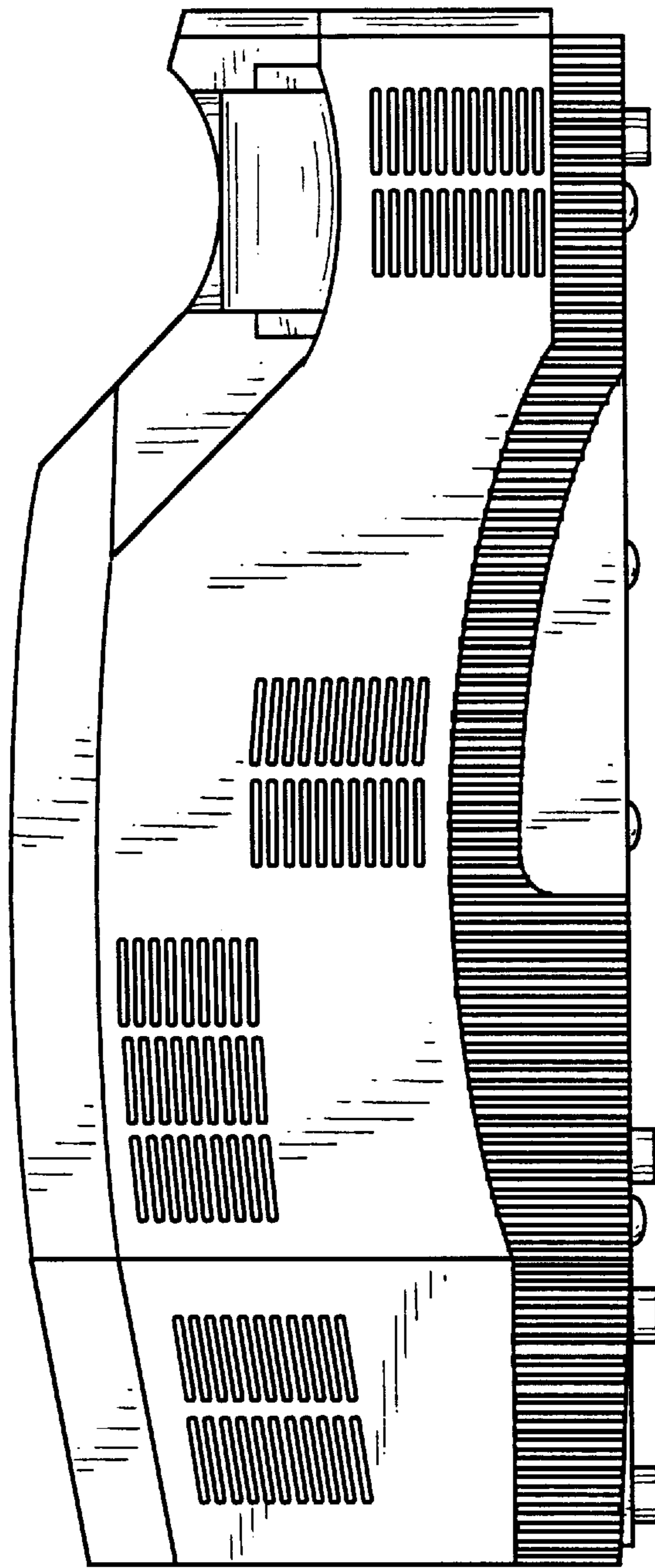

FIG. 13

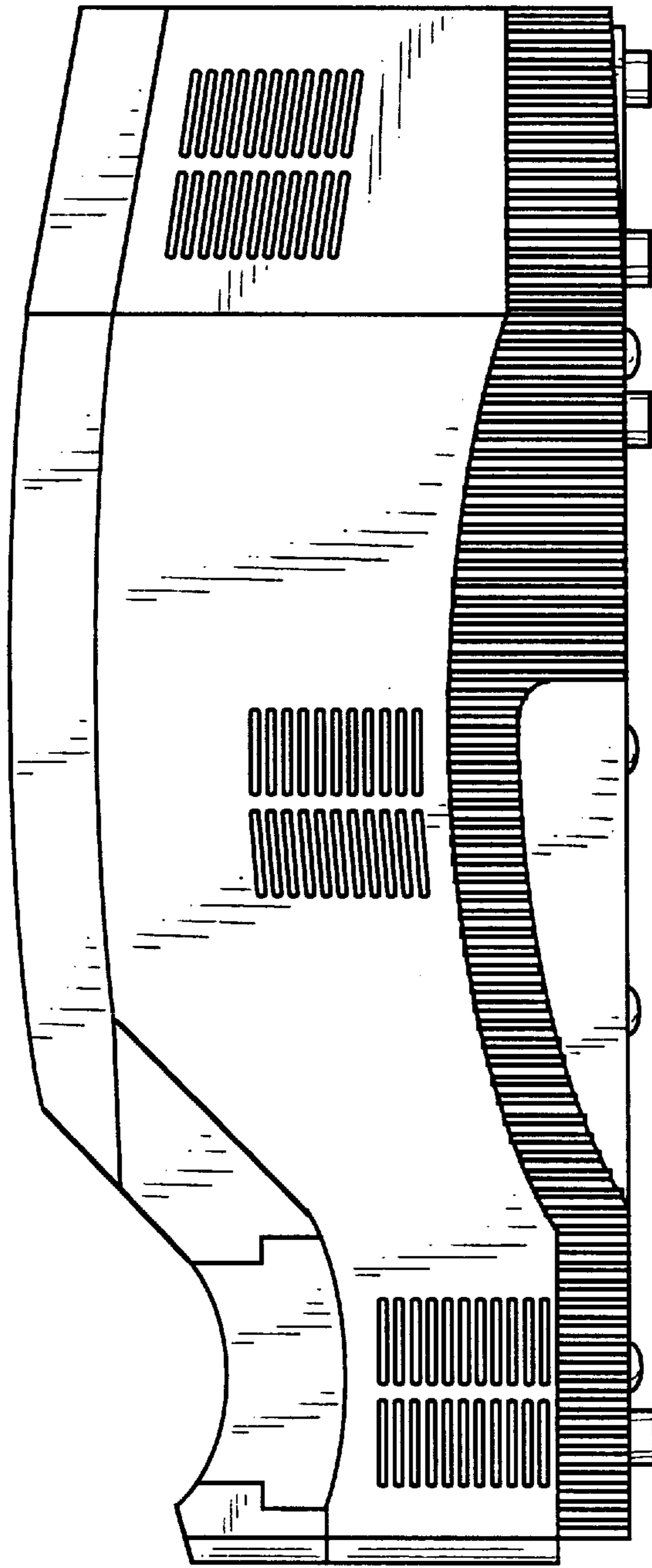

FIG. 14

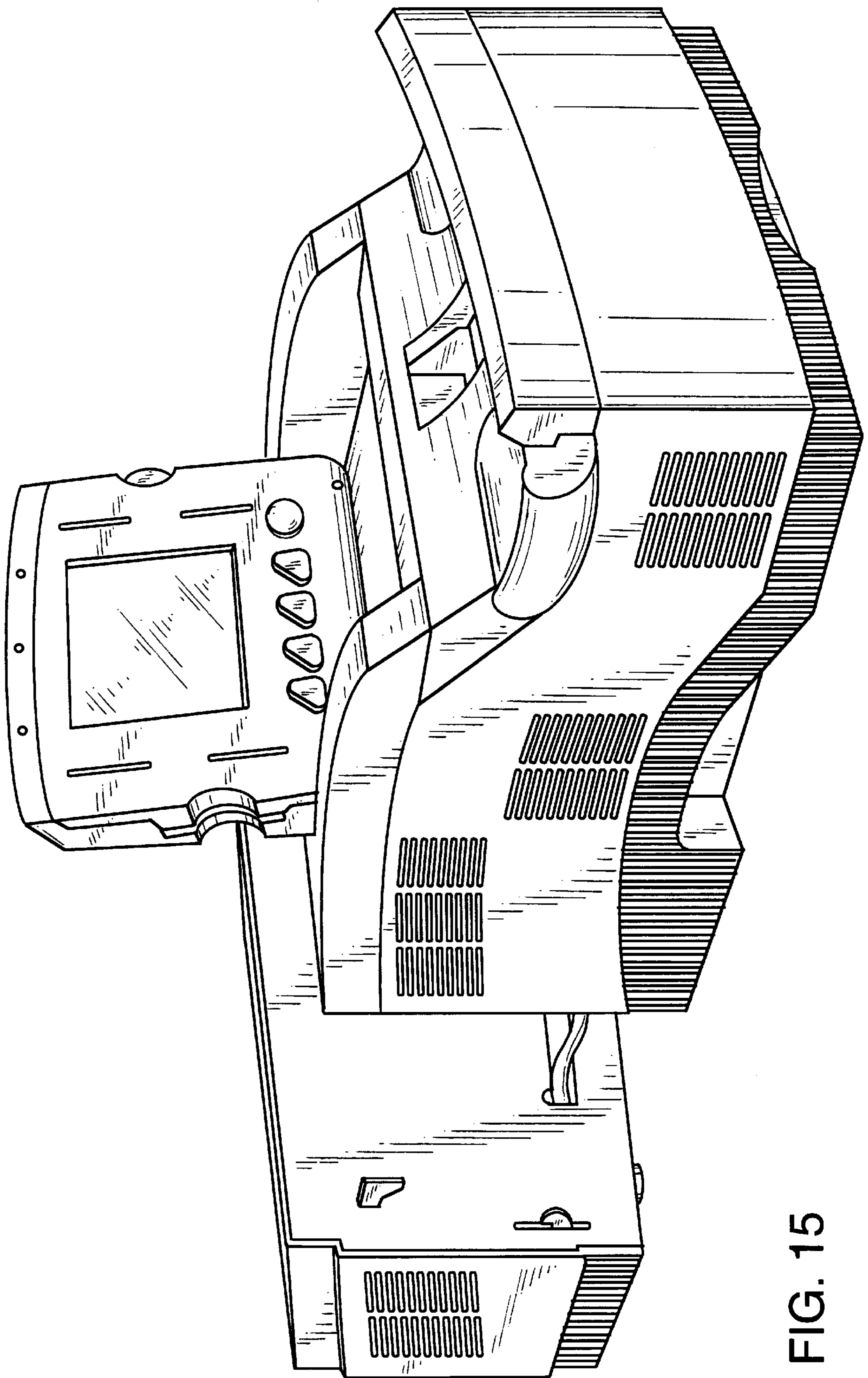

FIG. 15

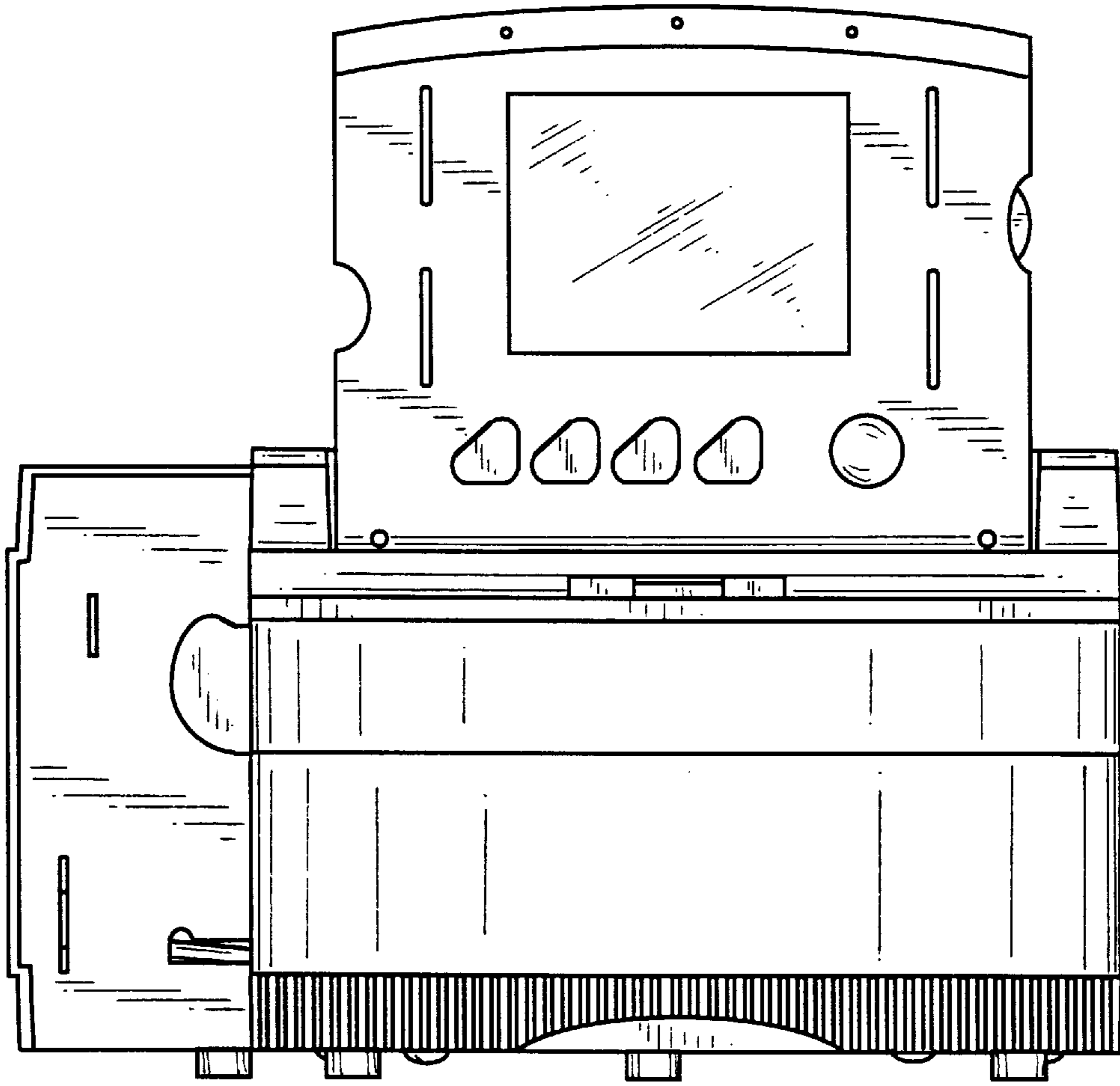

FIG. 16



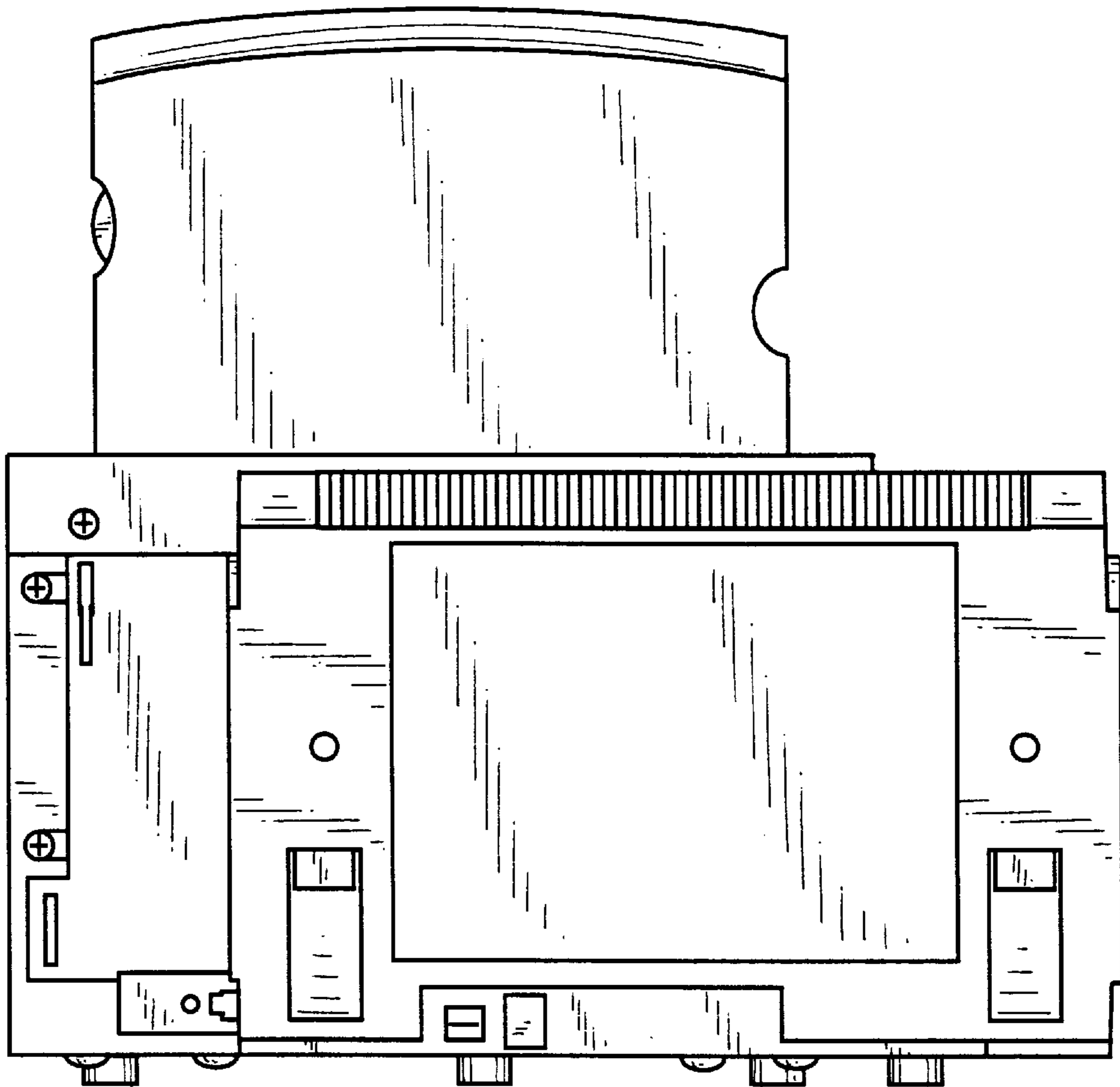

FIG. 17

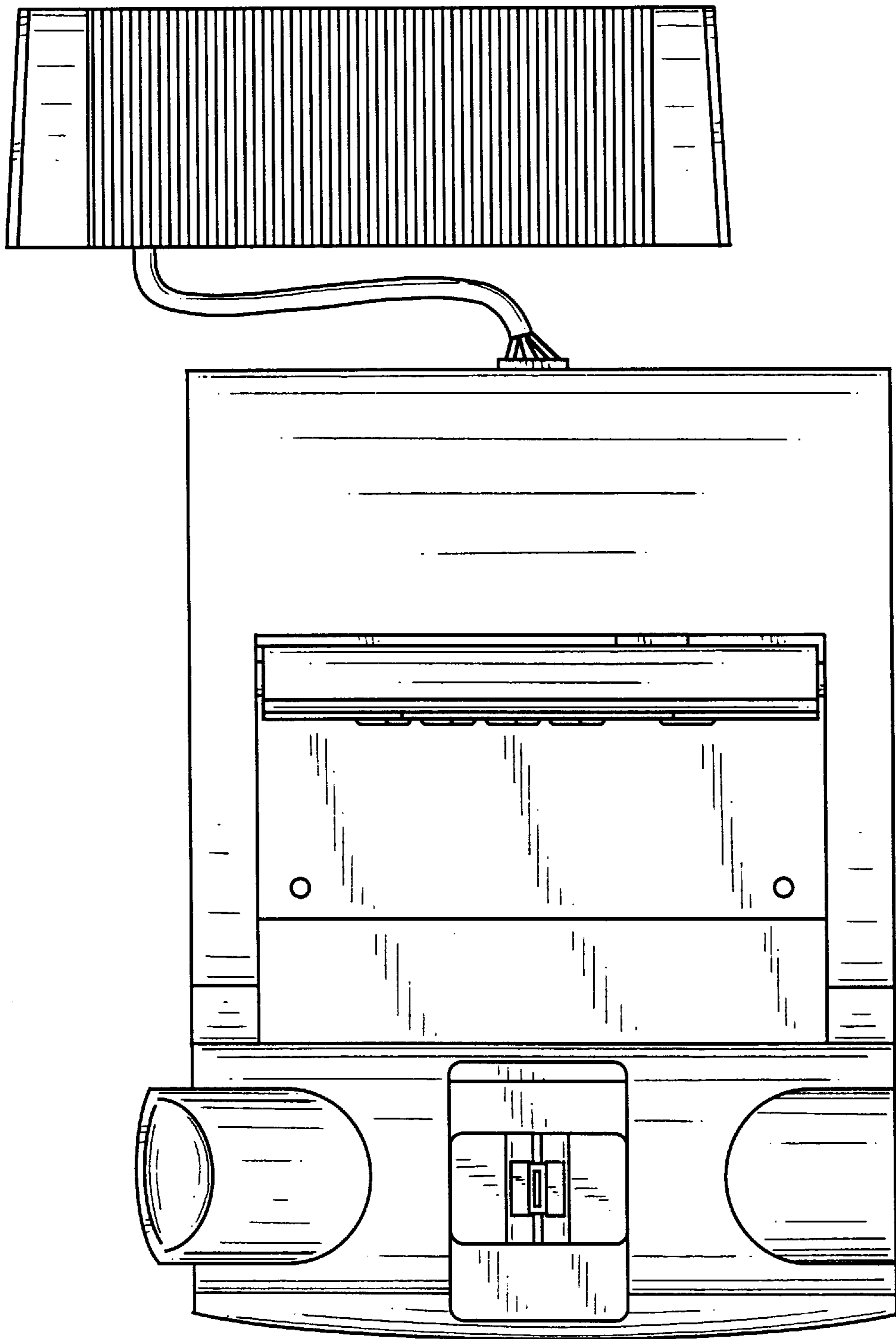

FIG. 18

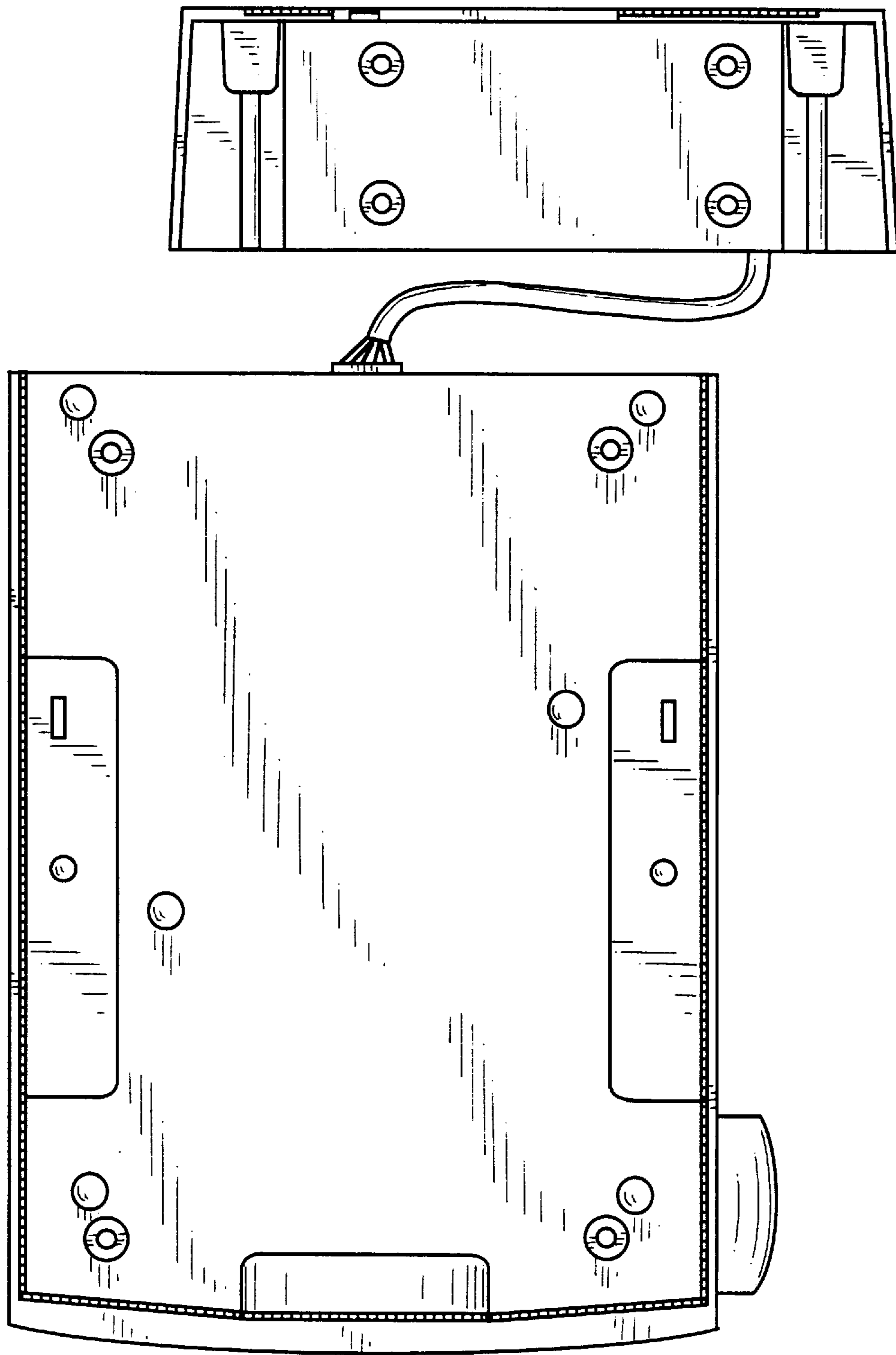

FIG. 19

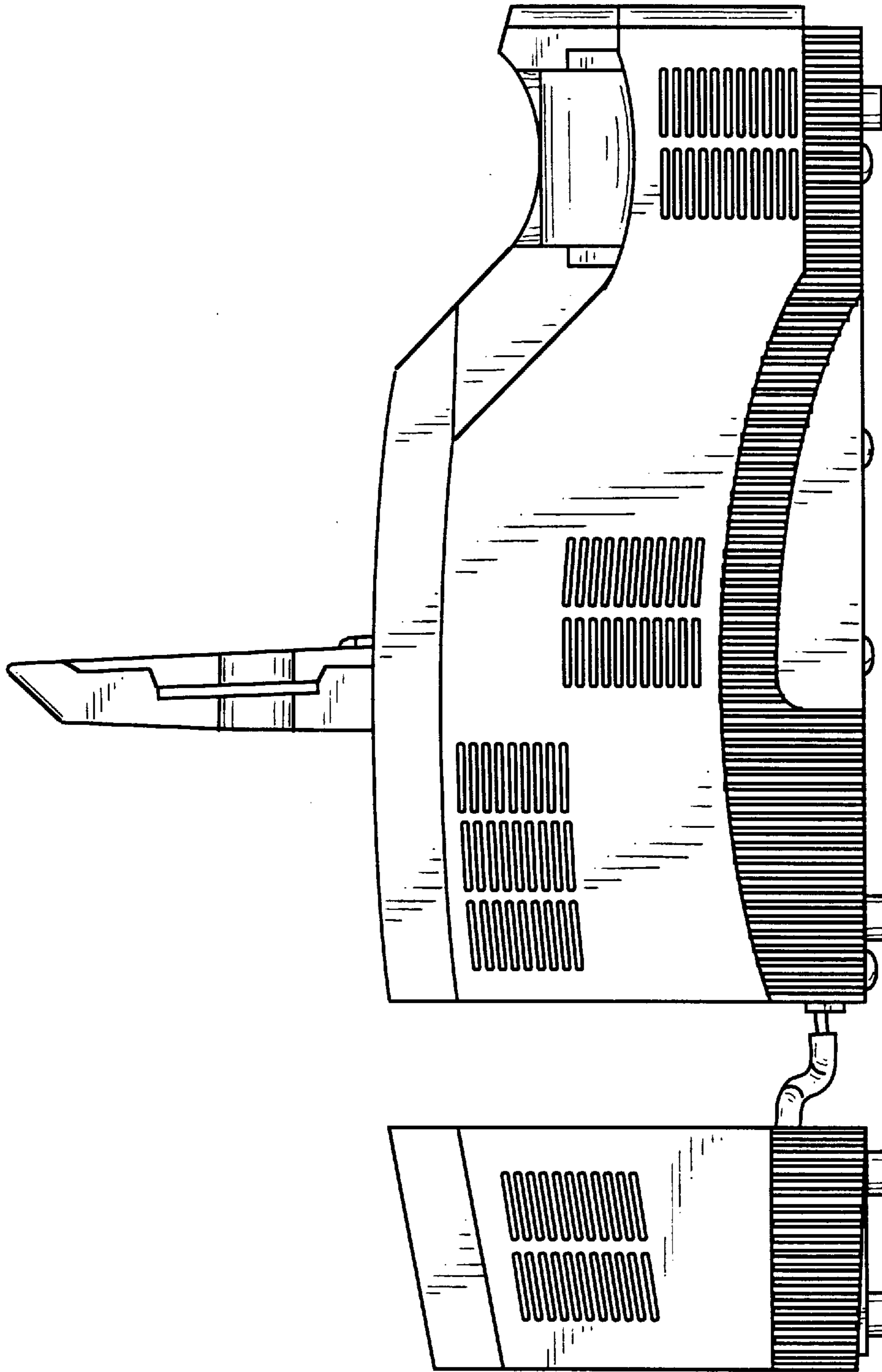

FIG. 20

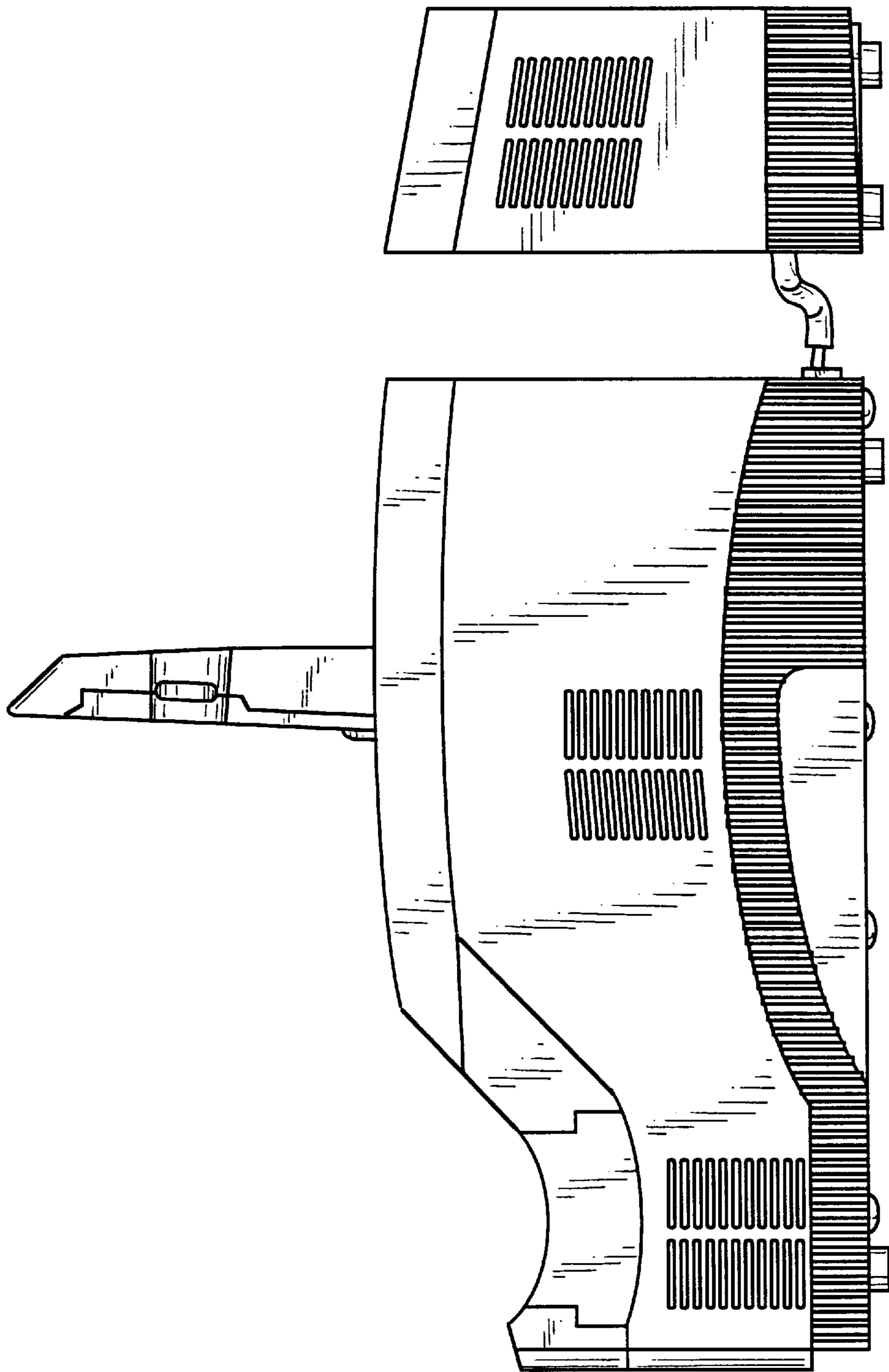

FIG. 21