



US00D404401S

United States Patent [19] Osborne

[11] Patent Number: **Des. 404,401**

[45] Date of Patent: ****Jan. 19, 1999**

[54] **FORECOURT FUEL PUMP**

[76] Inventor: **Graham W. Osborne**, 74 Yarmouth Road, North Walsham, Norfolk, England, NR28 9AU

[**] Term: **14 Years**

[21] Appl. No.: **79,987**

[22] Filed: **Nov. 25, 1997**

[30] **Foreign Application Priority Data**

May 28, 1997	[GB]	United Kingdom	2066109
May 28, 1997	[GB]	United Kingdom	2066110
May 28, 1997	[GB]	United Kingdom	2066111

[51] **LOC (6) Cl.** **15-02**

[52] **U.S. Cl.** **D15/9.1**

[58] **Field of Search** D15/9.1; 222/25, 222/71, 74, 75, 383.1; 137/234.6

[56] **References Cited**

U.S. PATENT DOCUMENTS

D. 247,134	1/1978	Geisler	D15/9.1
D. 258,361	2/1981	Gray	D15/9.1
D. 258,437	3/1981	Gray	D15/9.1
D. 266,673	10/1982	Monigle et al.	D15/9.1
D. 272,629	2/1984	Monigle et al.	D15/9.1
D. 273,791	5/1984	Monigle et al.	D15/9.1

Primary Examiner—Ralf Seifert

Attorney, Agent, or Firm—Andrus, Scales, Starke & Sawall

[57] **CLAIM**

I claim the ornamental design for a forecourt fuel pump, as shown and described.

DESCRIPTION

FIG. 1 is a front elevation of a first embodiment thereof; FIG. 2 is a side elevation of a first embodiment thereof; FIG. 3 is a top plan view of a first embodiment thereof; FIG. 4 is a rear elevation of a first embodiment thereof; FIG. 5 is another side elevation of a first embodiment thereof; FIG. 6 is a perspective view of a first embodiment thereof; FIG. 7 is a front elevation of a second embodiment thereof; FIG. 8 is a side elevation of a second embodiment thereof; FIG. 9 is a top plan view of a second embodiment thereof; FIG. 10 is a rear elevation of a second embodiment thereof; FIG. 11 is another side elevation of a second embodiment thereof; FIG. 12 is a perspective view of a second embodiment thereof; FIG. 13 is a front elevation of a third embodiment thereof; FIG. 14 is a side elevation of a third embodiment thereof; FIG. 15 is a top plan view of a third embodiment thereof; FIG. 16 is a rear elevation of a third embodiment thereof; FIG. 17 is another side elevation of a third embodiment thereof; and, FIG. 18 is a perspective view of a third embodiment thereof.

1 Claim, 6 Drawing Sheets

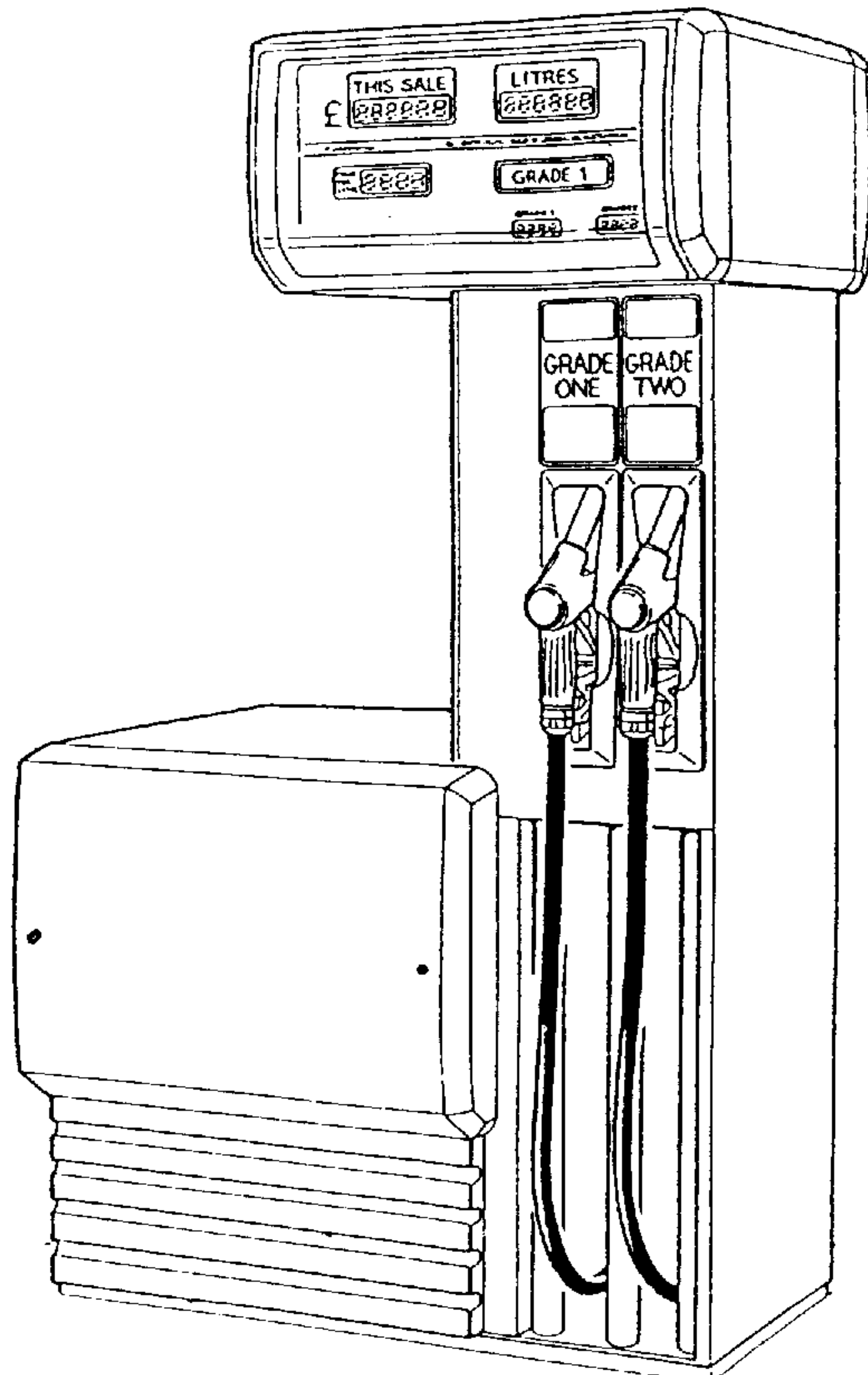

Figure 1

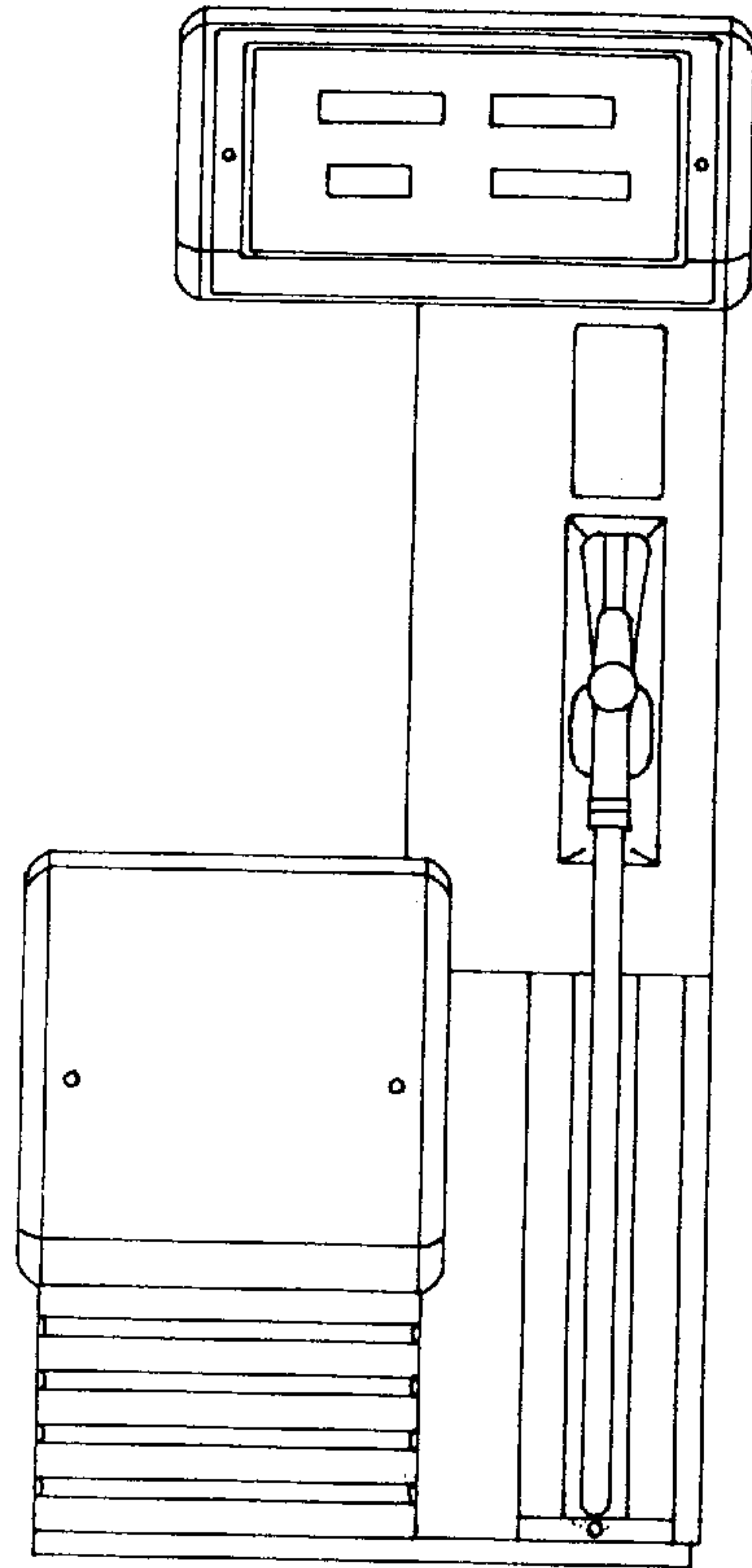

Figure 2

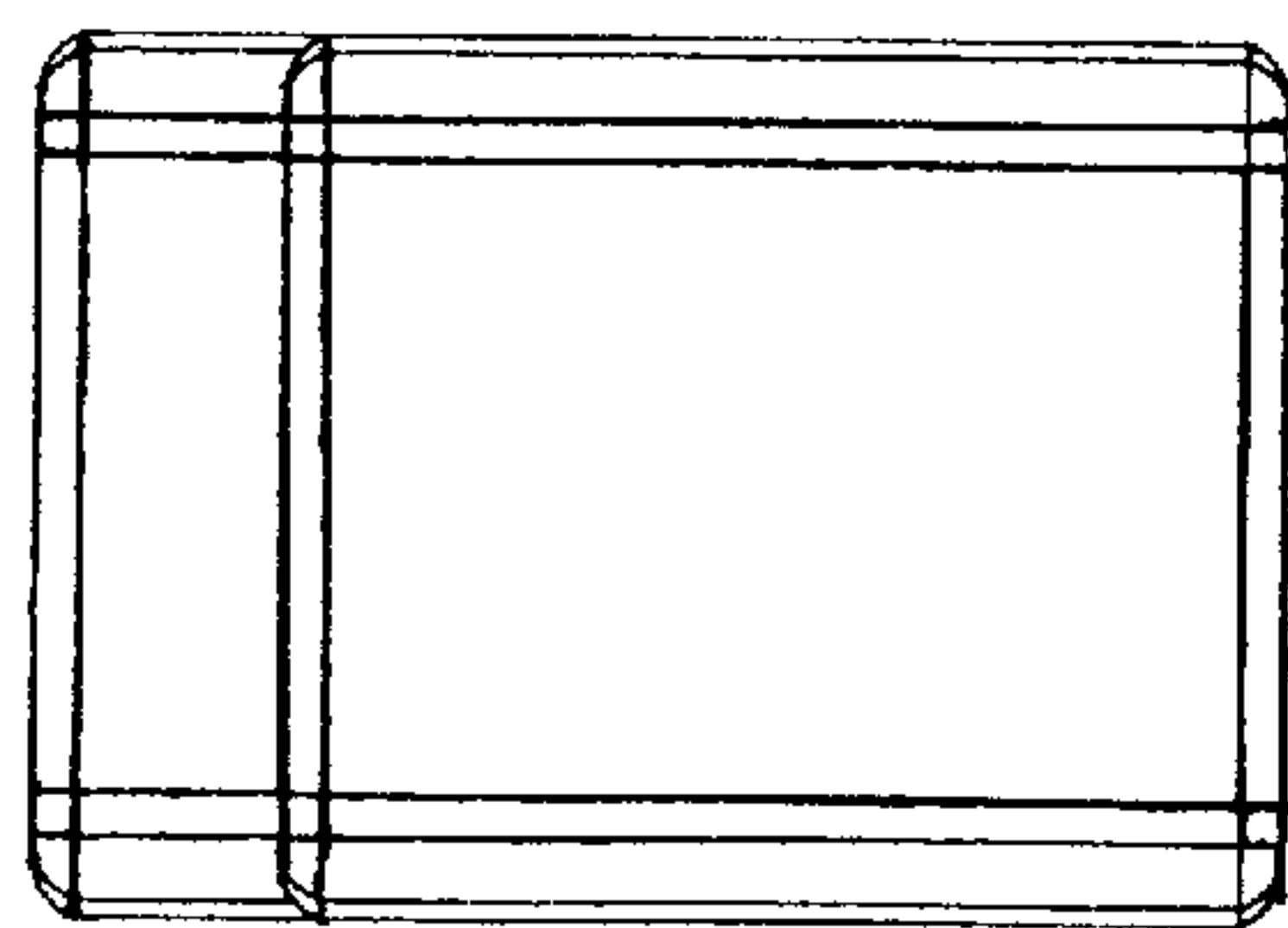
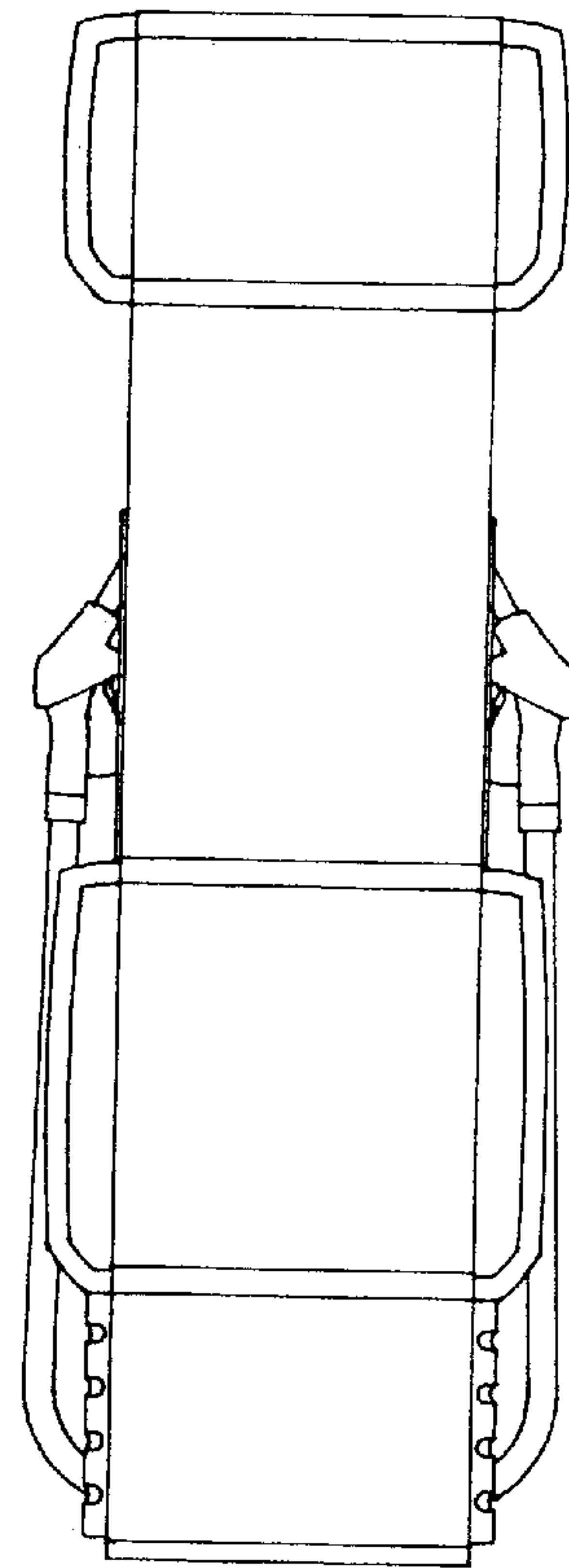

Figure 3

Figure 4

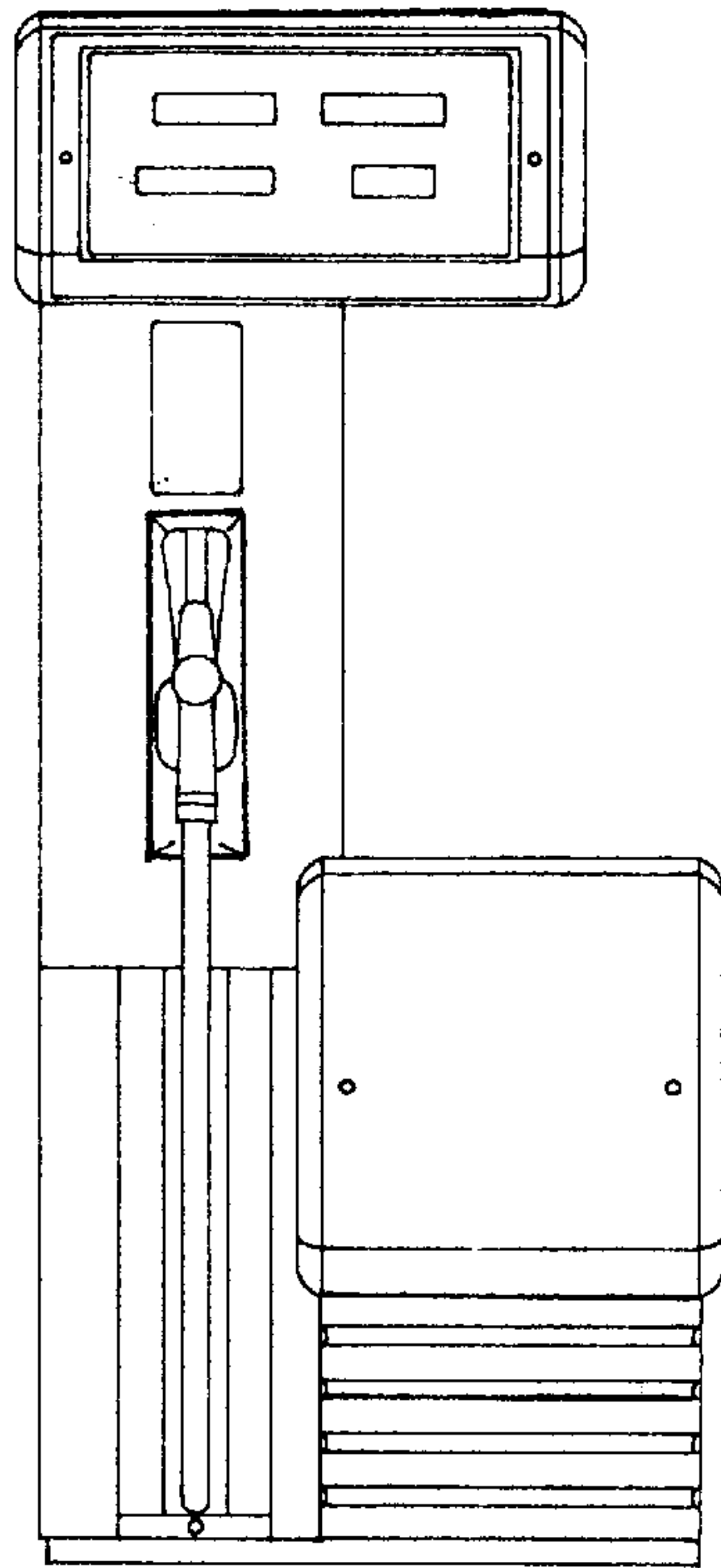

Figure 5

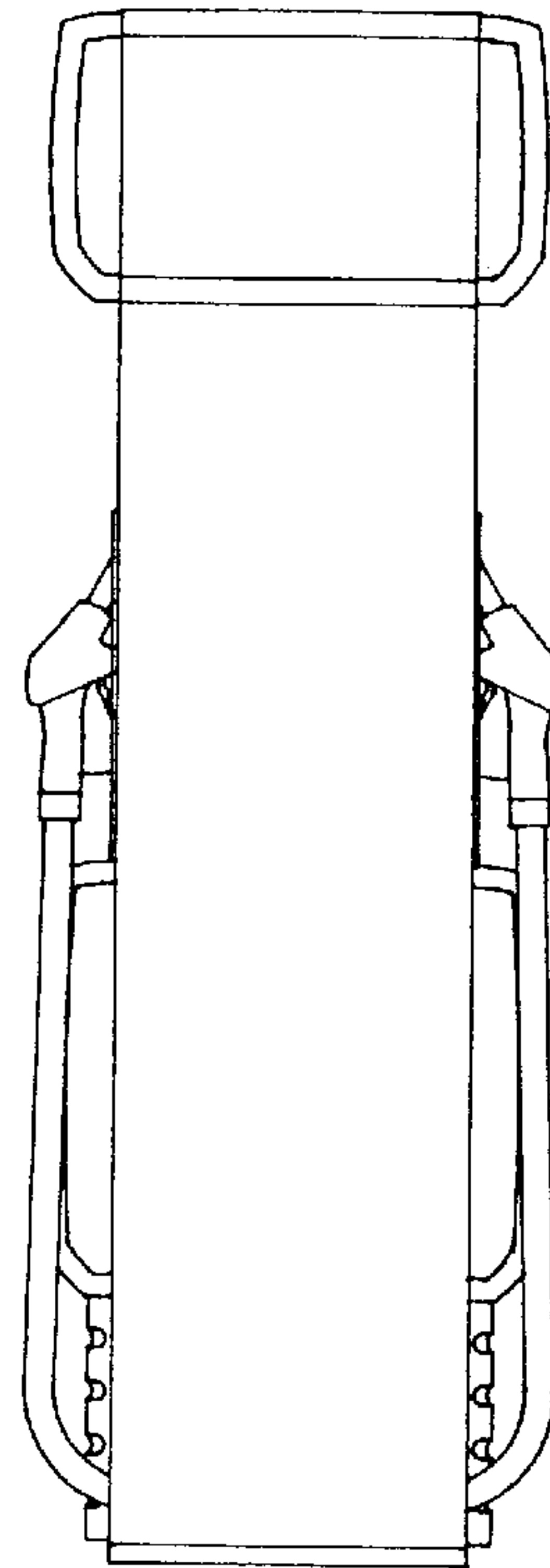

Figure 6

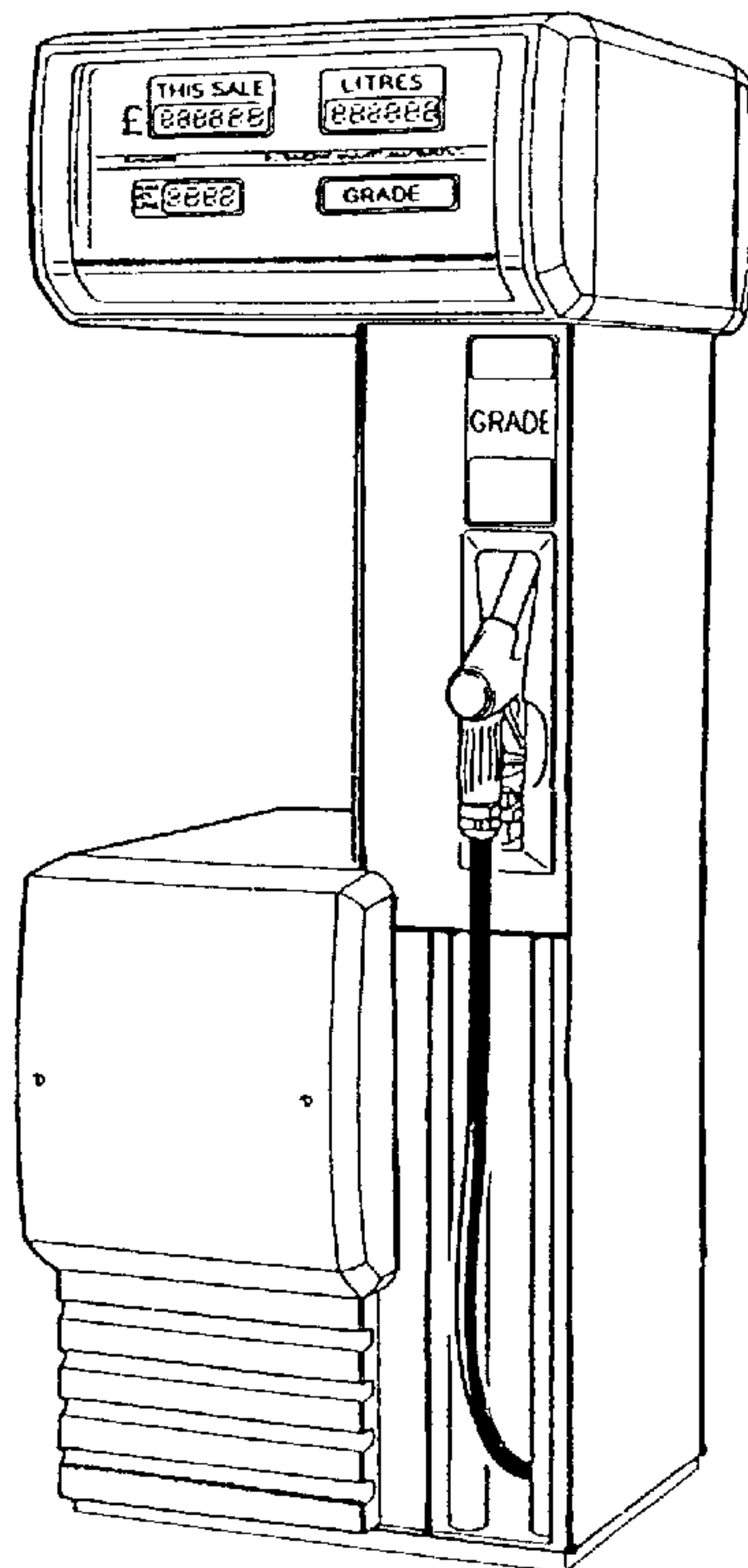

Figure 7

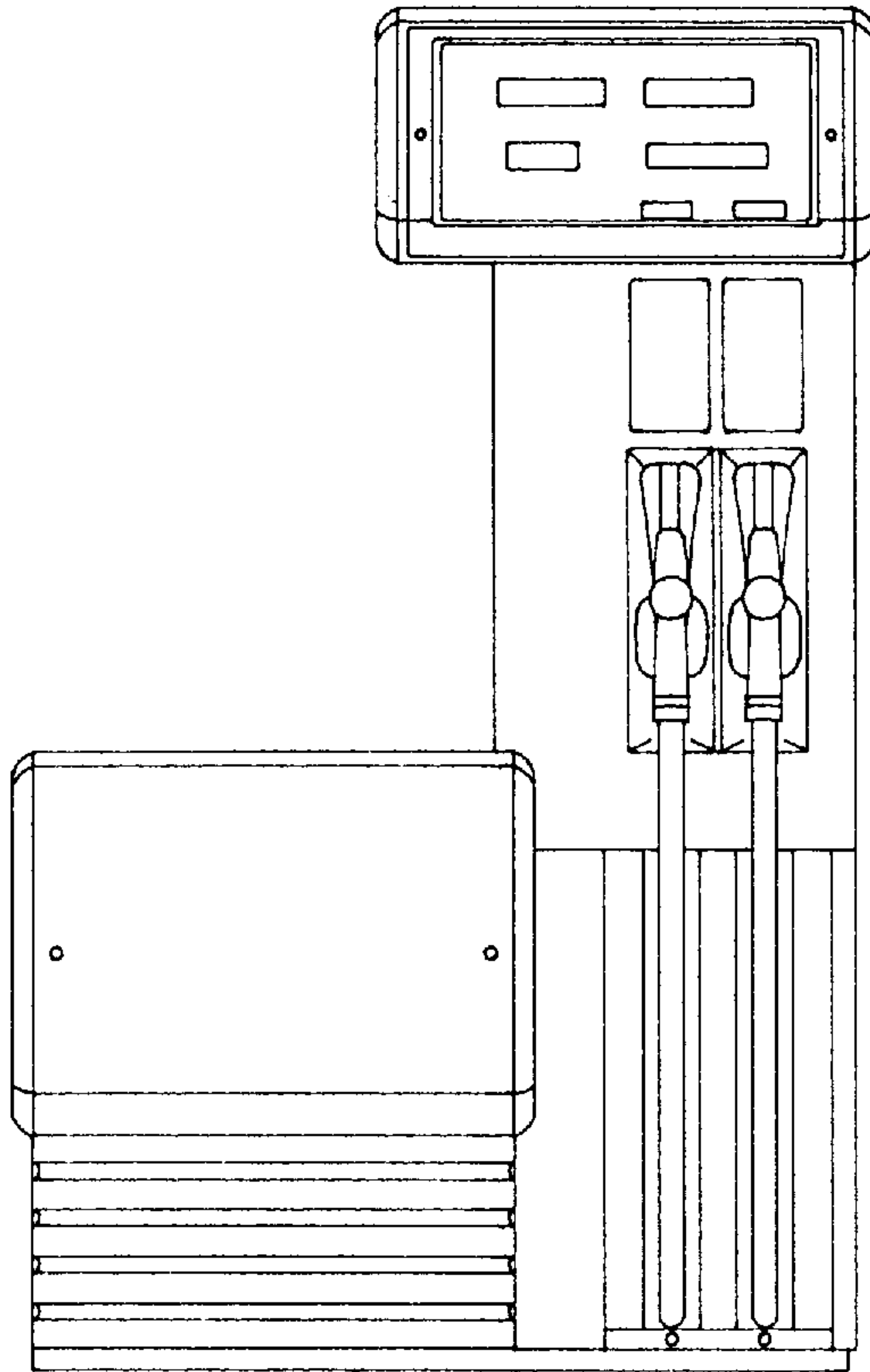

Figure 8

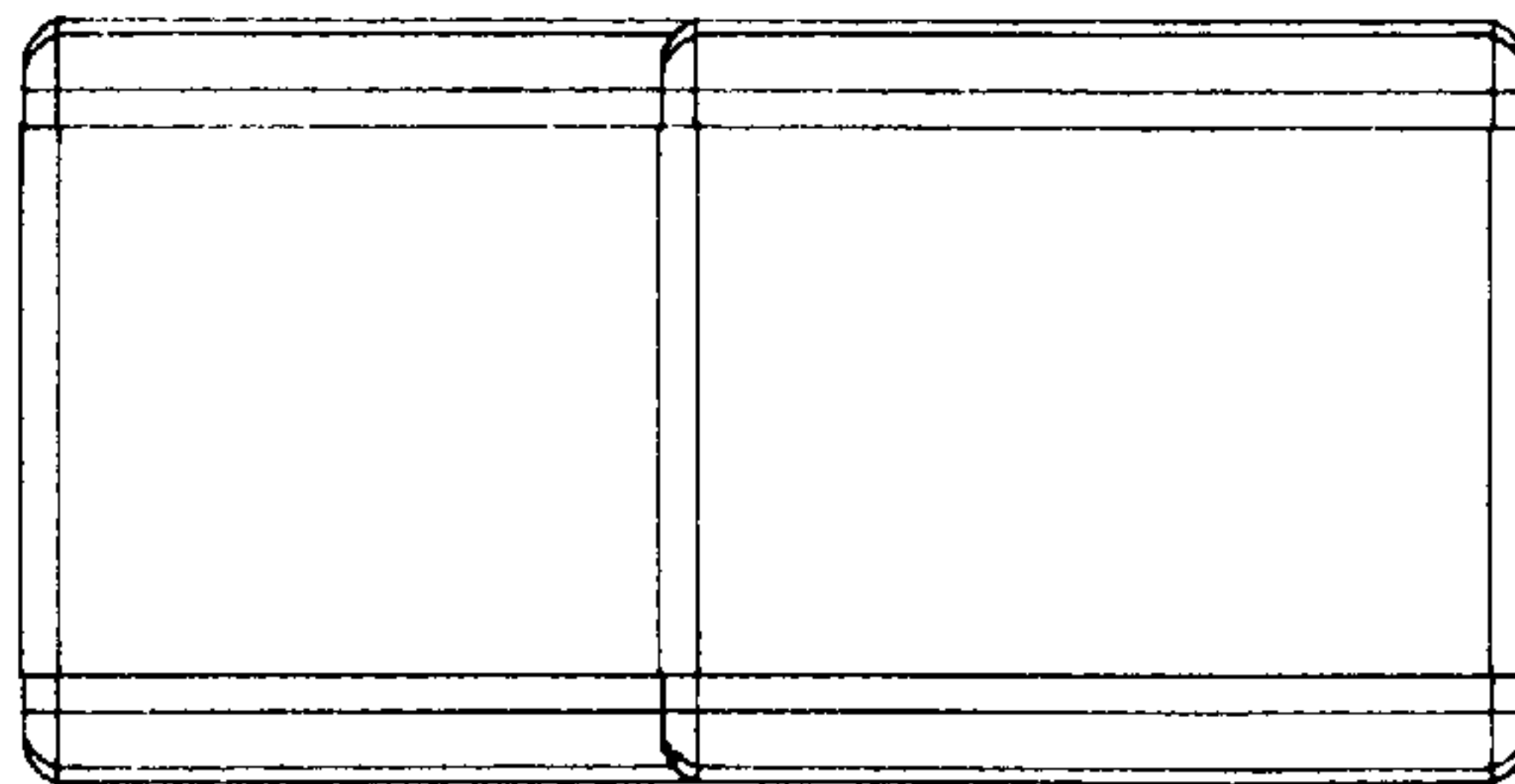
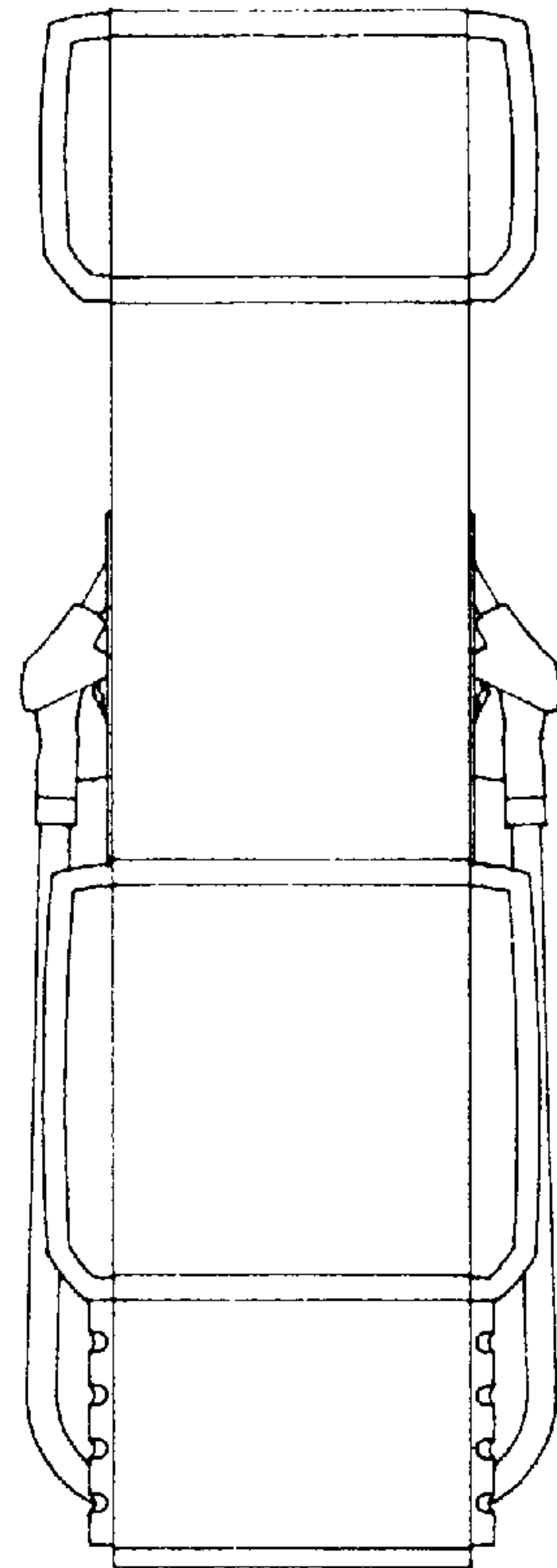

Figure 9

Figure 10

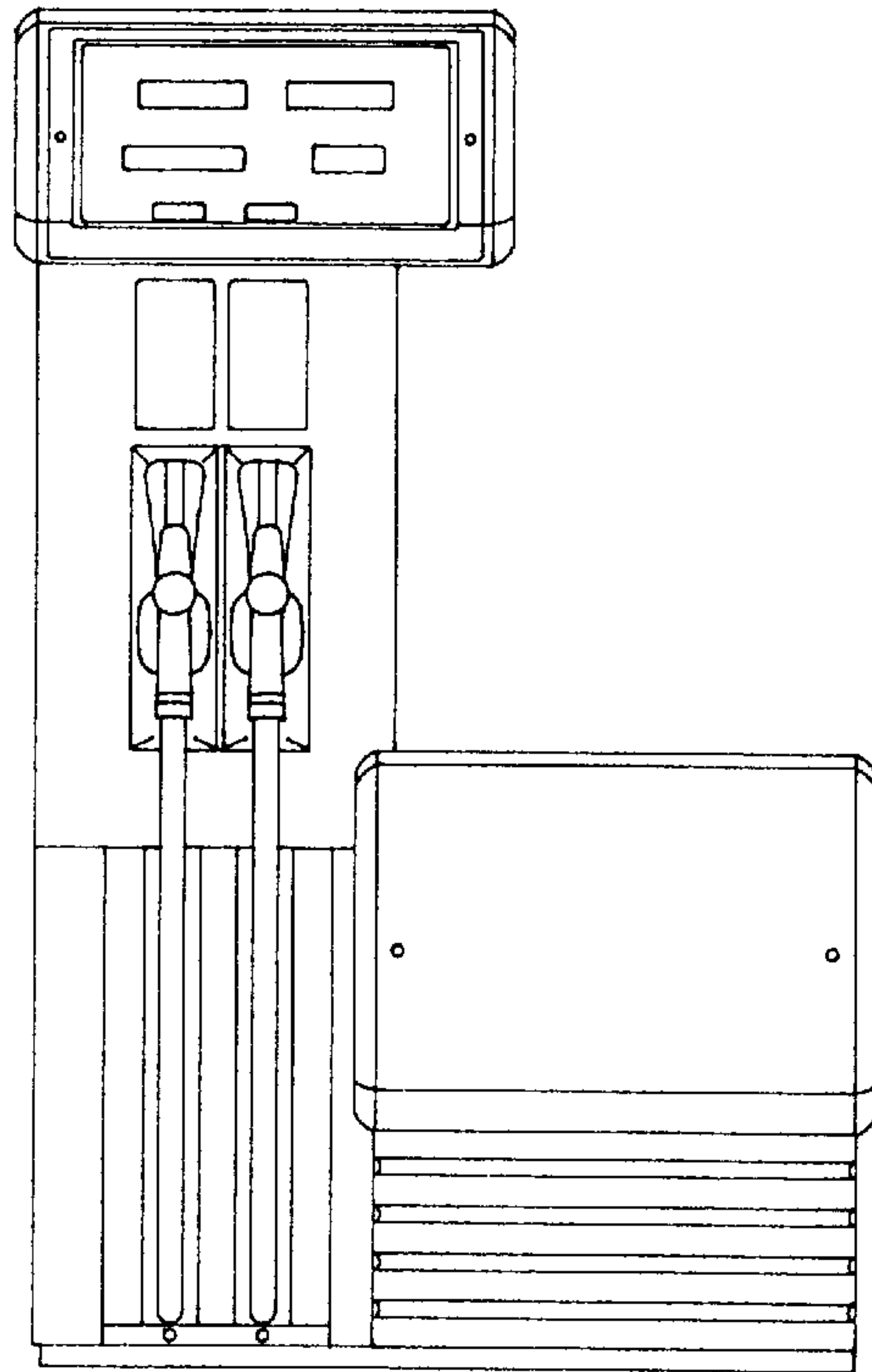

Figure 11

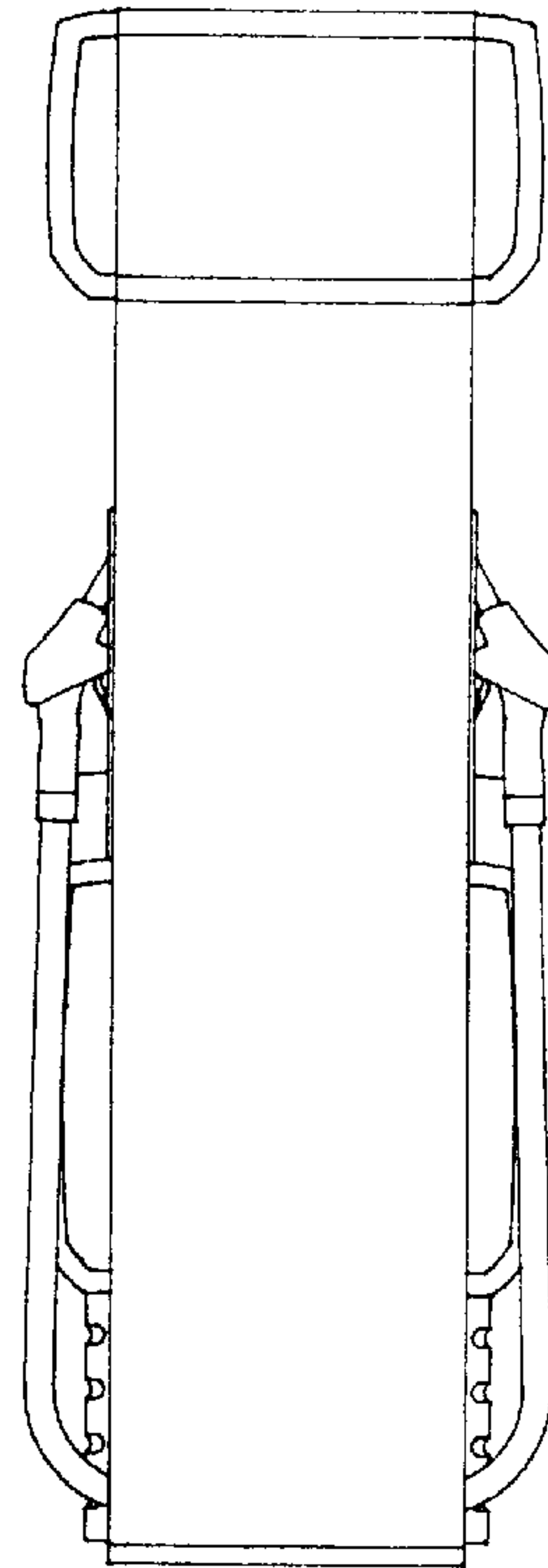

Figure 12

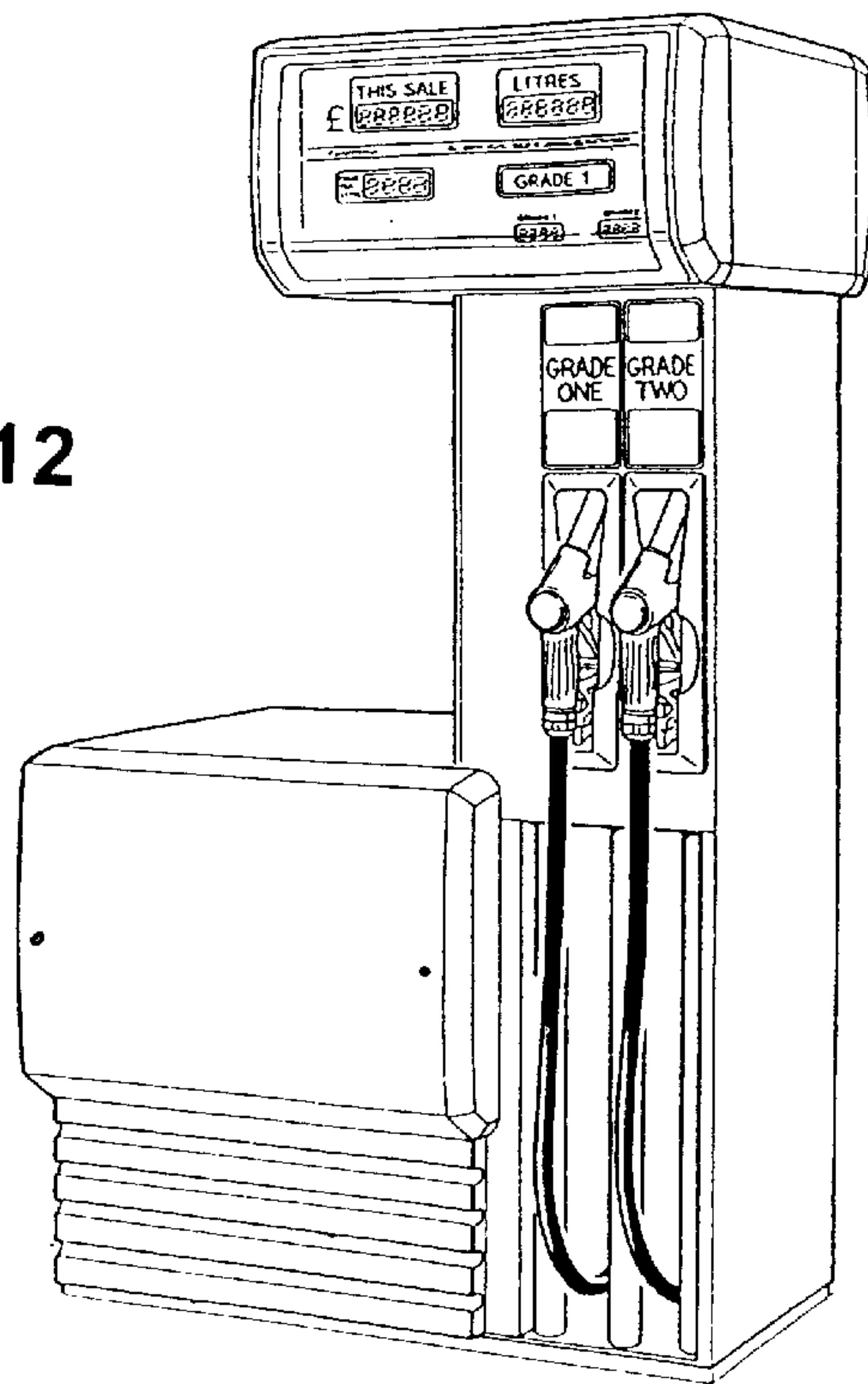

Figure 13

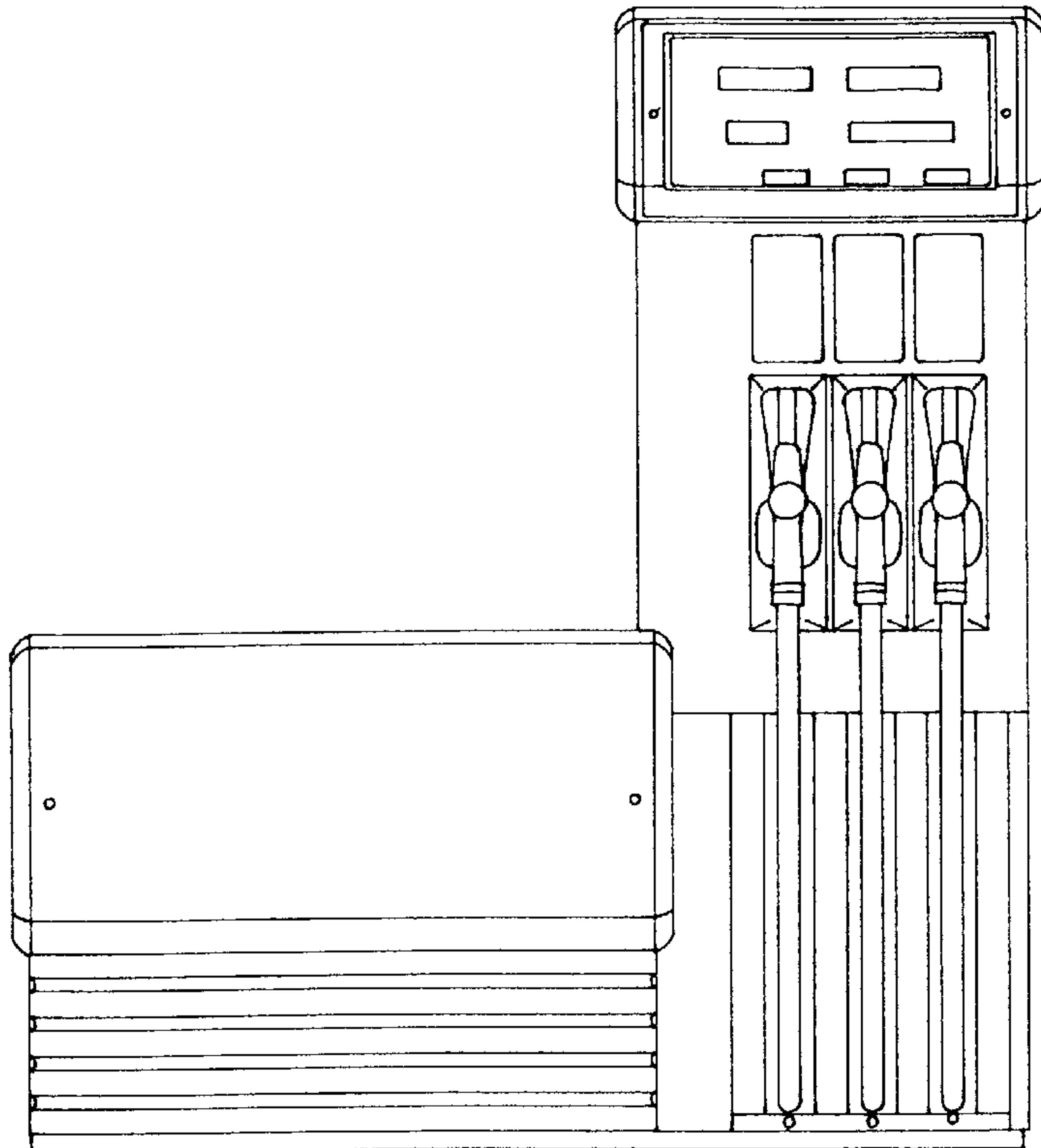

Figure 14

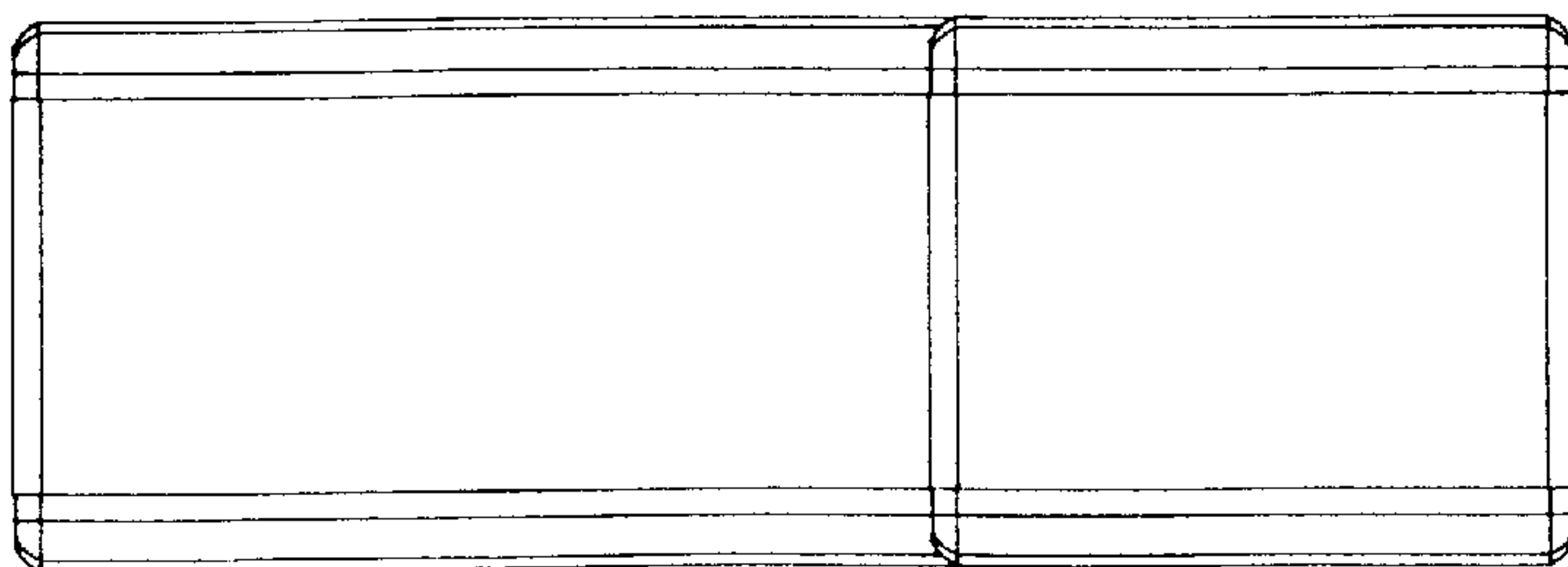
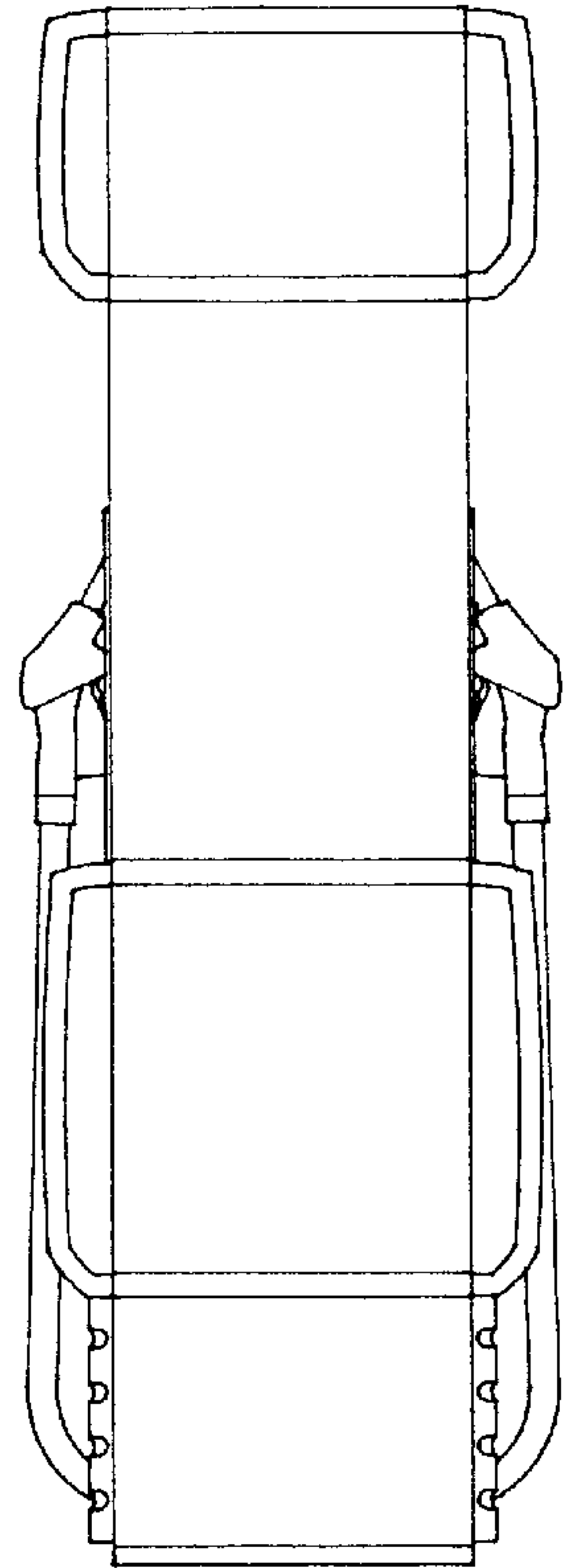

Figure 15

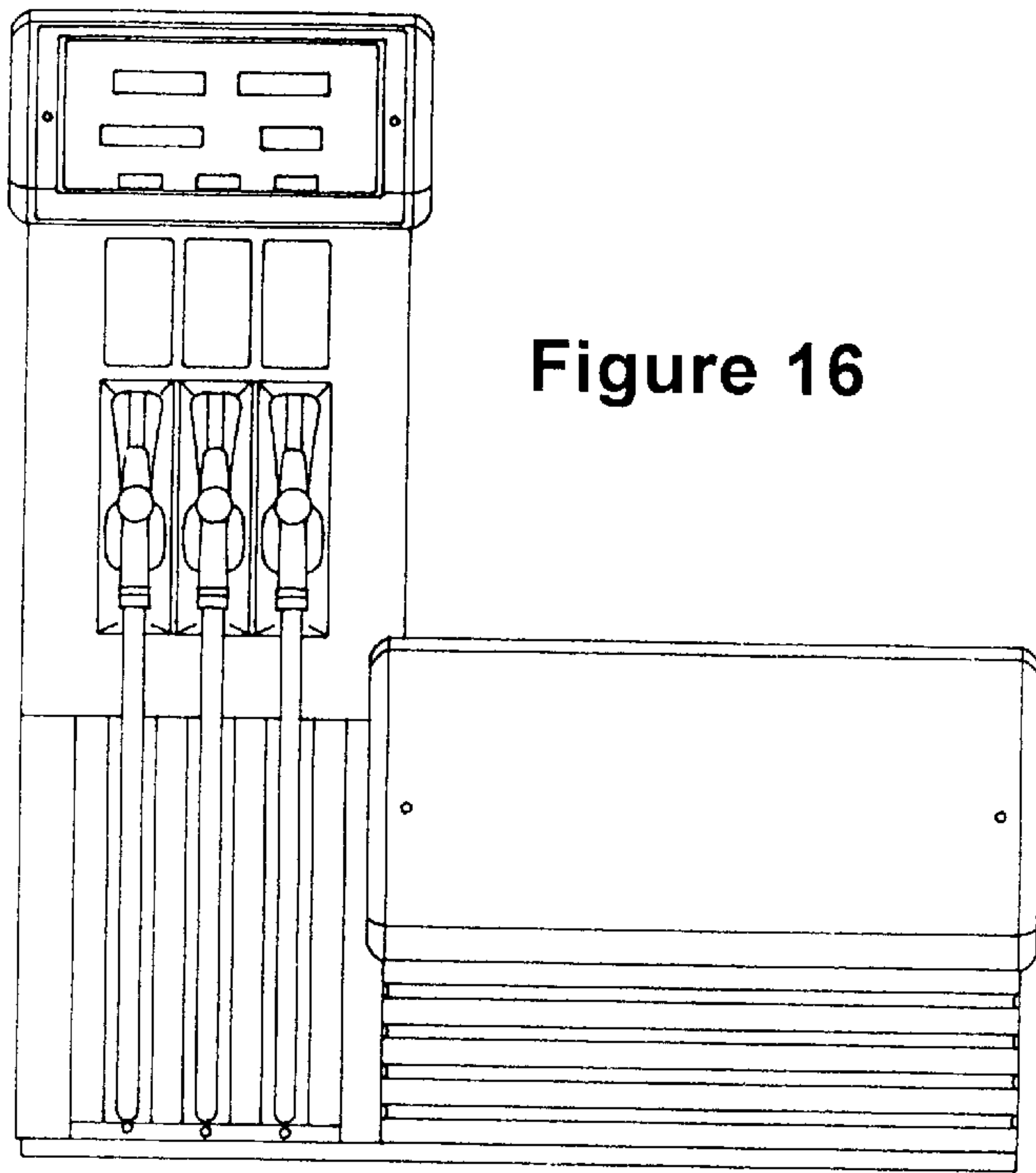

Figure 16

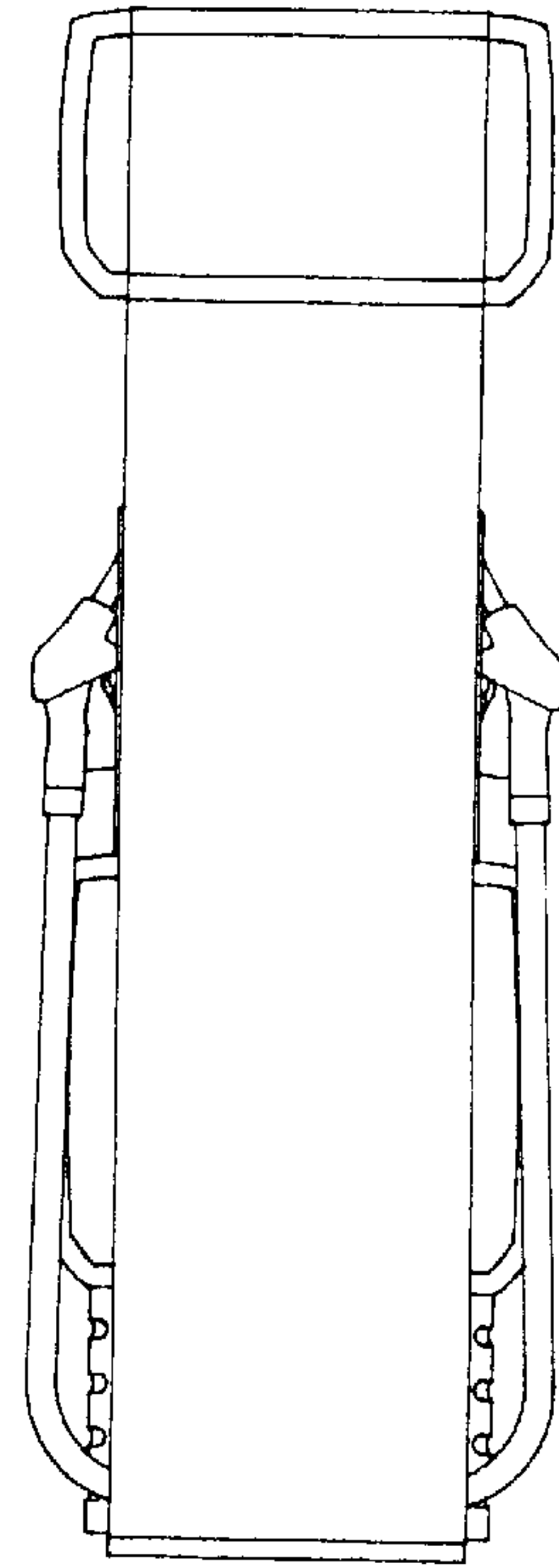

Figure 17

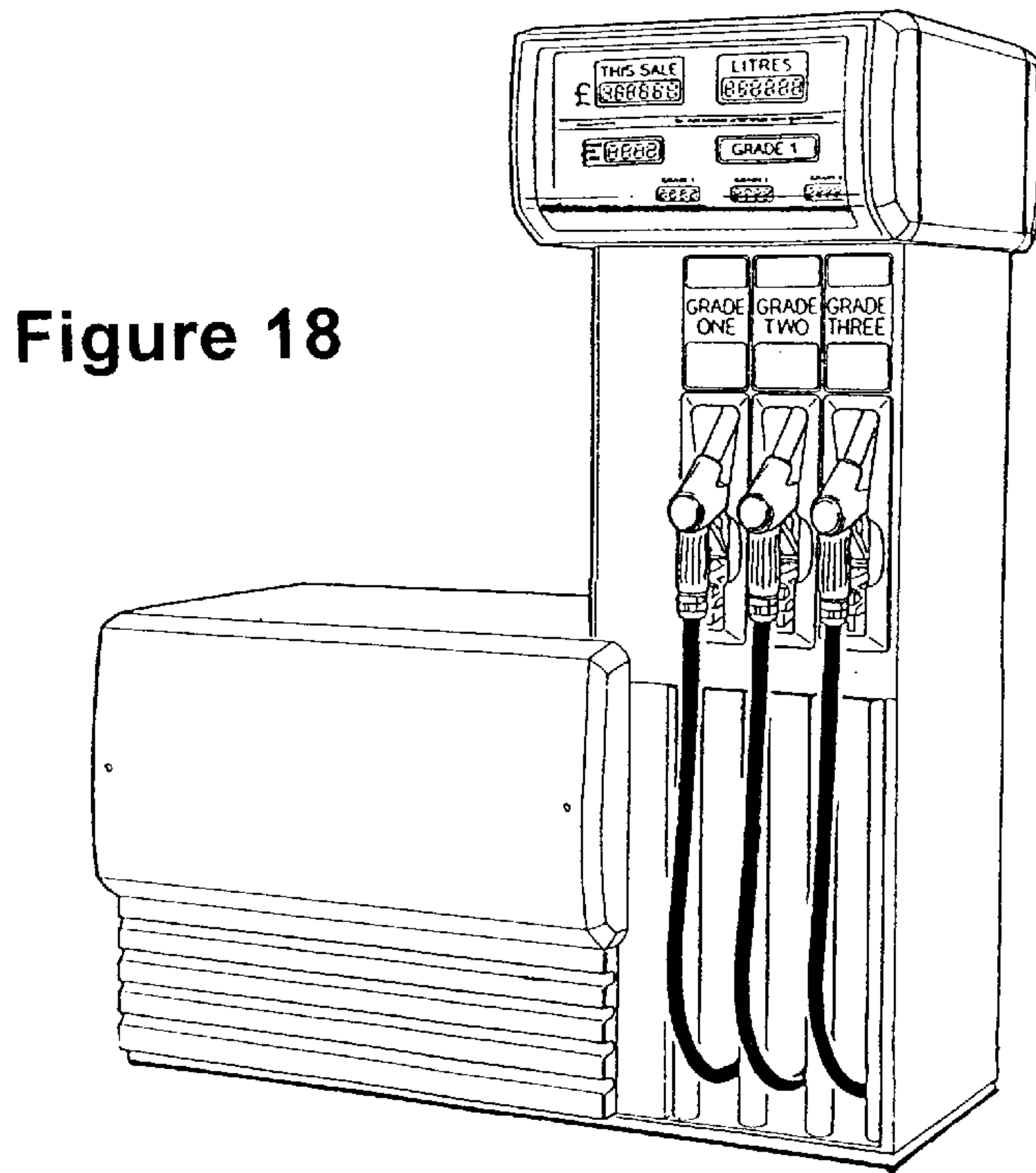

Figure 18