



US00D404042S

# United States Patent [19]

Allen

[11] Patent Number: **Des. 404,042**

[45] Date of Patent: **\*\*Jan. 12, 1999**

[54] **CONCRETE SAW WITH STABILIZED CARRIAGE AND BLADE CONTROL**

[75] Inventor: **J. Dewayne Allen**, Paragould, Ark.

[73] Assignee: **Allen Engineering Corp.**, Paragould, Ark.

[\*\*] Term: **14 Years**

[21] Appl. No.: **78,252**

[22] Filed: **Oct. 23, 1997**

[51] **LOC (6) Cl.** ..... **15-09**

[52] **U.S. Cl.** ..... **D15/127**

[58] **Field of Search** ..... D15/127, 133; 125/4, 13.01, 14; 264/154; 299/39

[56] **References Cited**

**U.S. PATENT DOCUMENTS**

1,736,538	1/1929	Kurtz .	
2,468,336	4/1949	Lewis .....	262/20
2,673,725	3/1954	Coates .....	262/20
2,700,256	1/1955	Lewis .....	51/170
3,357,745	12/1967	Cooper .....	299/39
3,656,468	4/1972	Welden .....	125/13
3,663,060	5/1972	Shatwell et al. ....	299/39
3,747,981	7/1973	Zuzelo .....	299/39
3,778,110	12/1973	Staab .....	299/39
3,779,607	12/1973	Staab .....	299/414
4,145,086	3/1979	Ishihara .....	299/15
4,188,934	2/1980	Reinhardt et al. ....	125/4
4,769,201	9/1988	Chiuminatta et al. ....	264/154
4,840,431	6/1989	Jedick .....	299/39
4,889,675	12/1989	Chiuminatta et al. ....	264/154
4,928,662	5/1990	Chiuminatta et al. ....	125/13.01
4,938,201	7/1990	Chiuminatta et al. ....	125/13.01

5,056,499	10/1991	Chiuminatta et al. ....	125/14
5,086,750	2/1992	Chiuminatta et al. ....	125/13.01
5,167,215	12/1992	Harding, Jr. ....	125/13.01
5,575,271	11/1996	Chiuminatta et al. ....	125/13.01

**OTHER PUBLICATIONS**

Razorback GM-150 Concrete Saw Operation & Maintenance Manual—Allen Engineering Corp.

Razorback GM-400 “Green Concrete Saw” Brochure Allen Engineering Corp.

Razorback GM-400 Concrete Saw Operation & Maintenance Manual—Allen Engineering Corp.

Soff-Cut International 03346/50F Buyline 7354.

“Protest Under MPEP 1900” Submitted Nov. 22, 1995 Re Applicant: Edward Zuzela Title: Green Concrete Cutting Saw.

Razorback GM-150 Concrete Saw Brochure Allen Engineering Corporation.

*Primary Examiner*—Antoine Duval Davis

*Attorney, Agent, or Firm*—Stephen D. Carver

[57] **CLAIM**

The ornamental design for a concrete saw with stabilized carriage and blade control, as shown.

**DESCRIPTION**

FIG. 1 is a right front perspective view of my new saw; FIG. 2 is a left front perspective view; FIG. 3 is an enlarged right side elevational view thereof; FIG. 4 is an enlarged left side elevational view thereof; FIG. 5 is an enlarged front elevational view thereof; FIG. 6 is a bottom plan view; and, FIG. 7 is a top plan view.

**1 Claim, 7 Drawing Sheets**

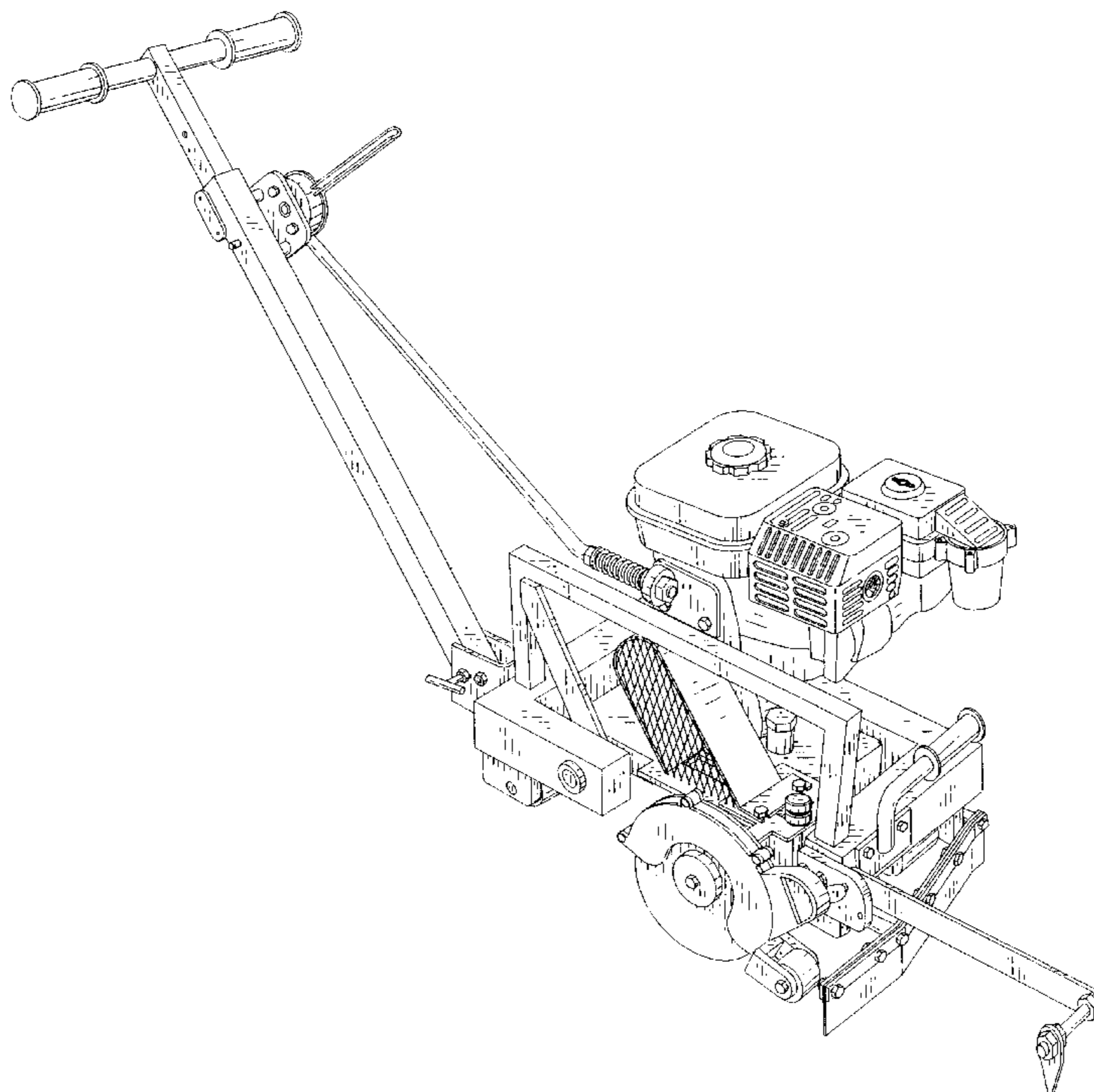

FIG. 1

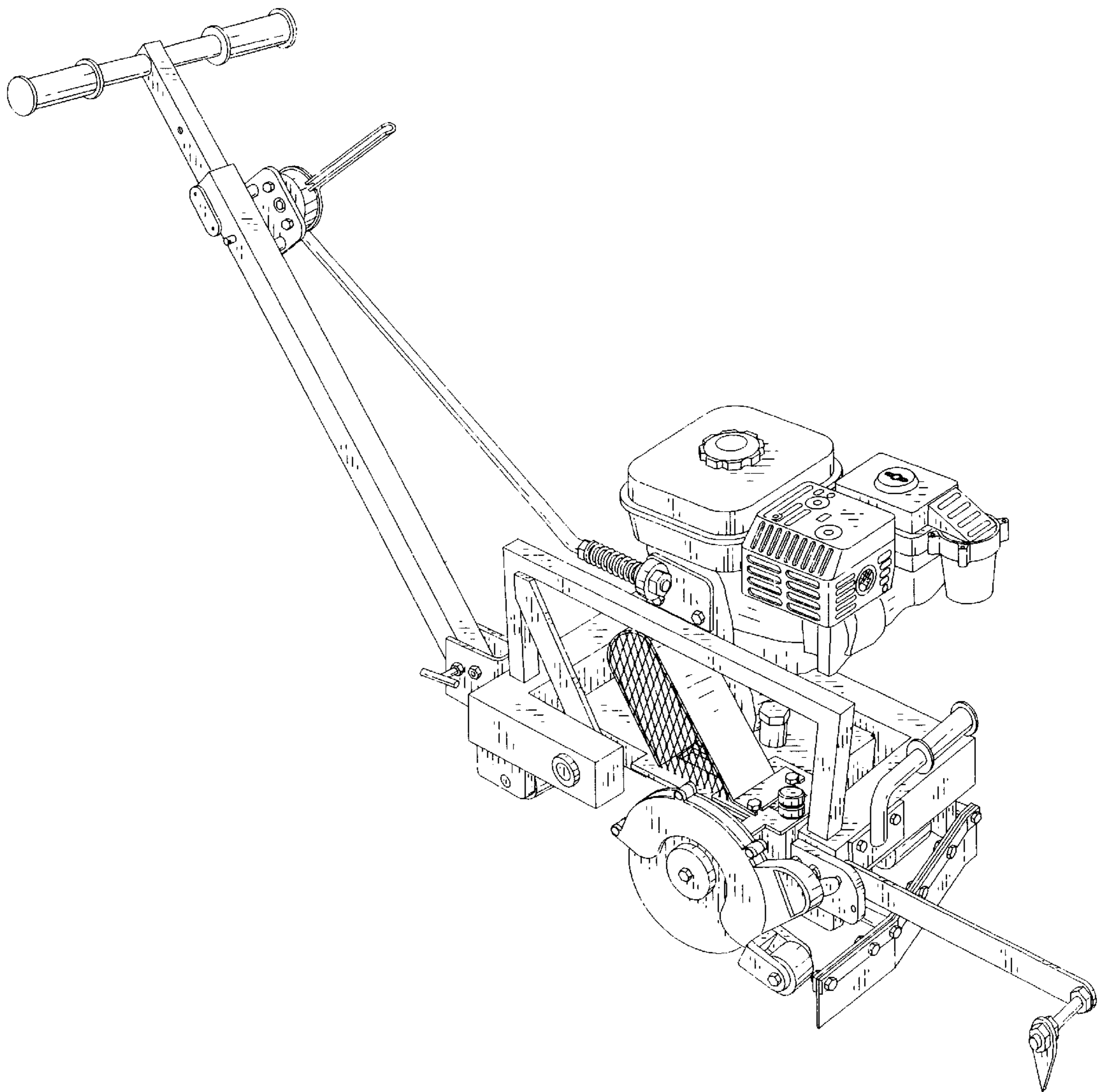

FIG. 2

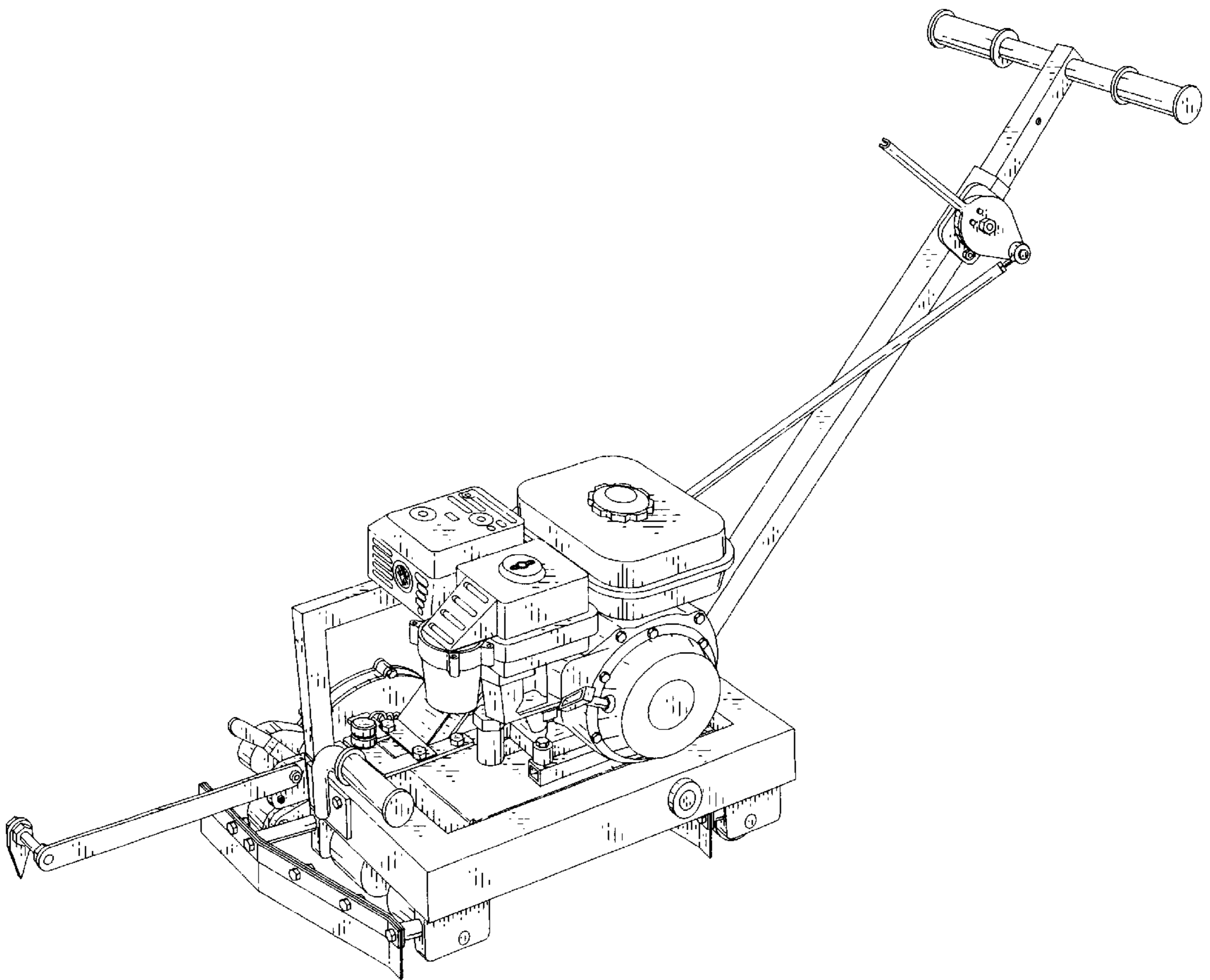
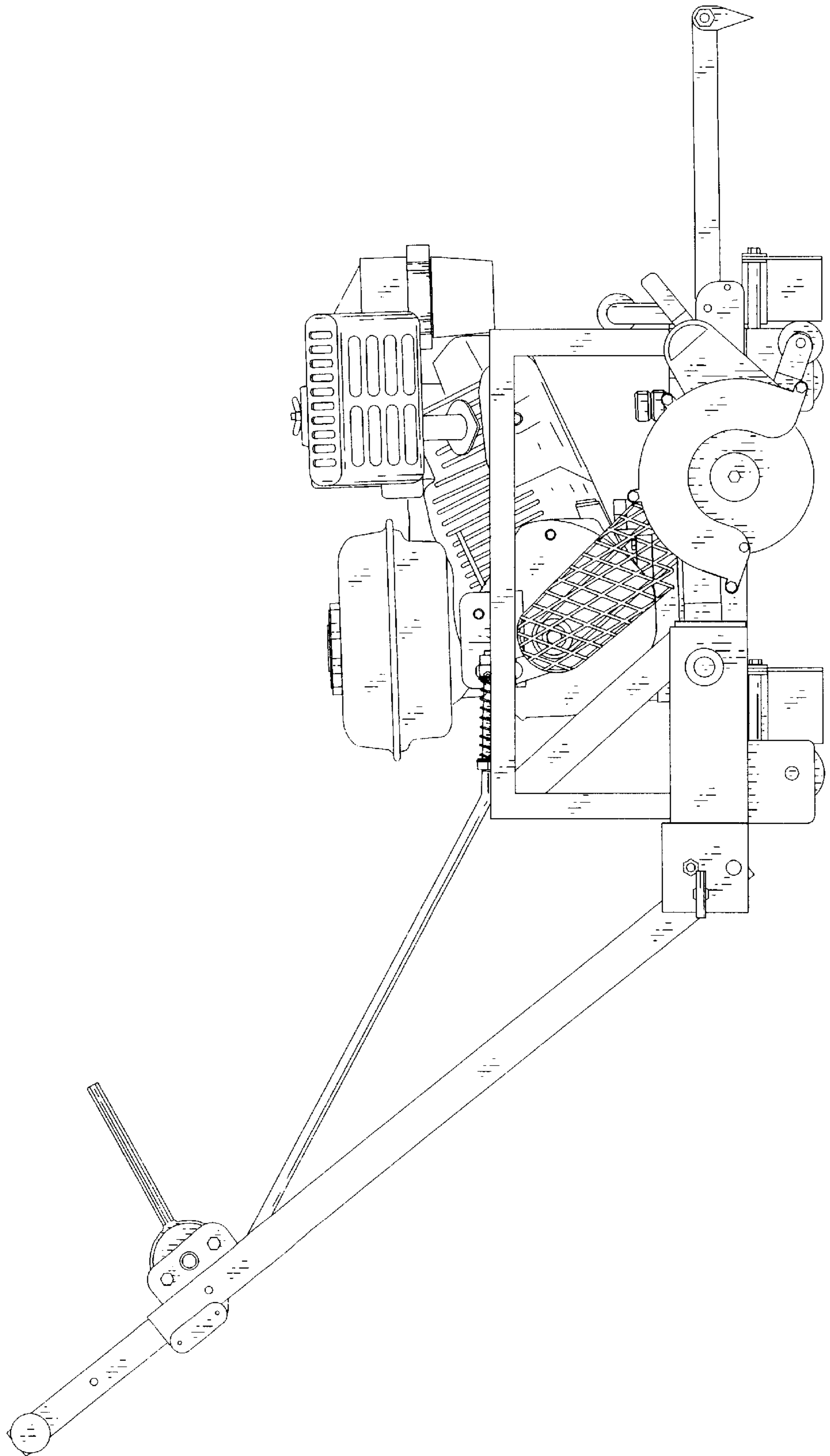

FIG. 3



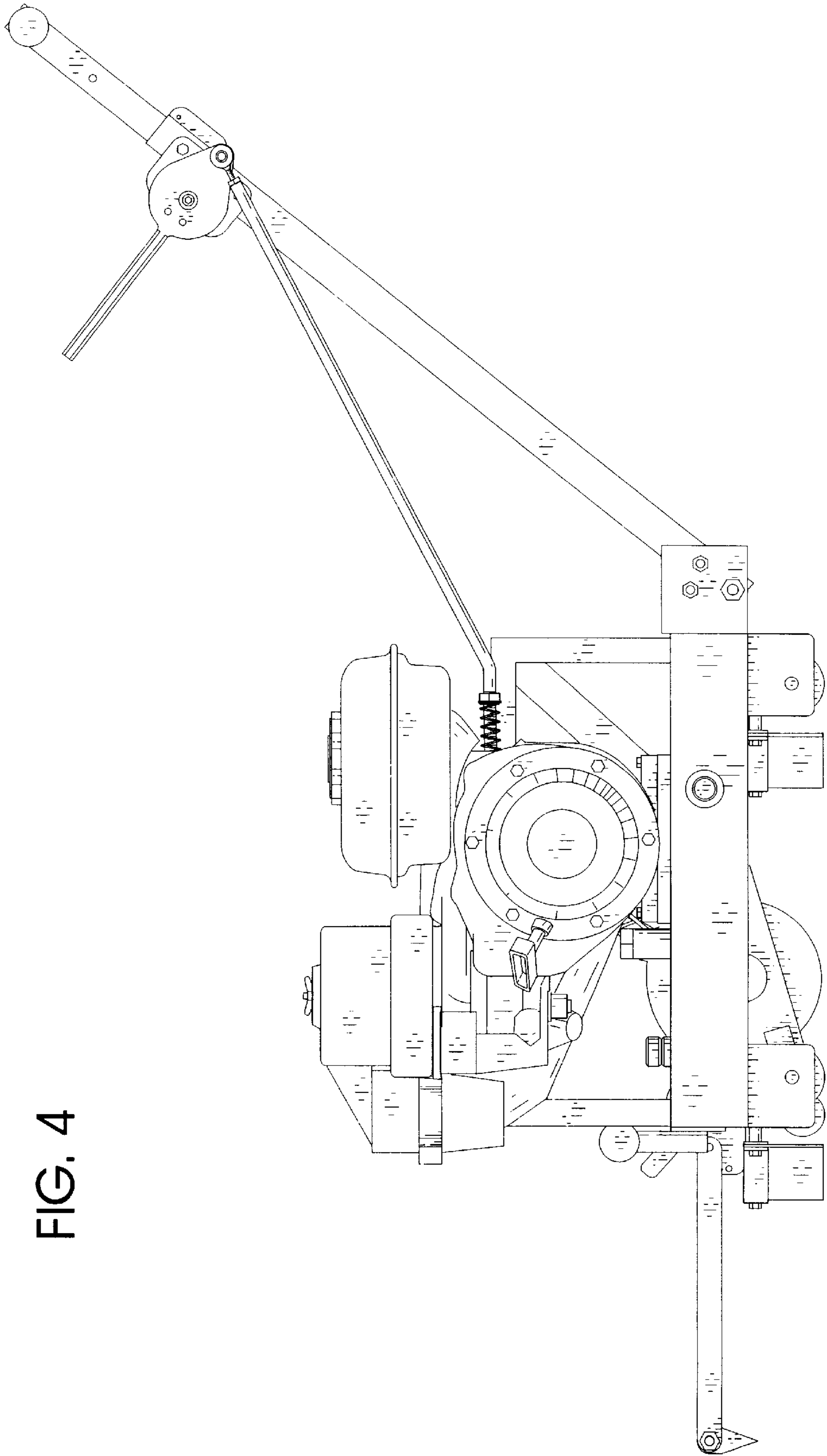

FIG. 4

FIG. 5

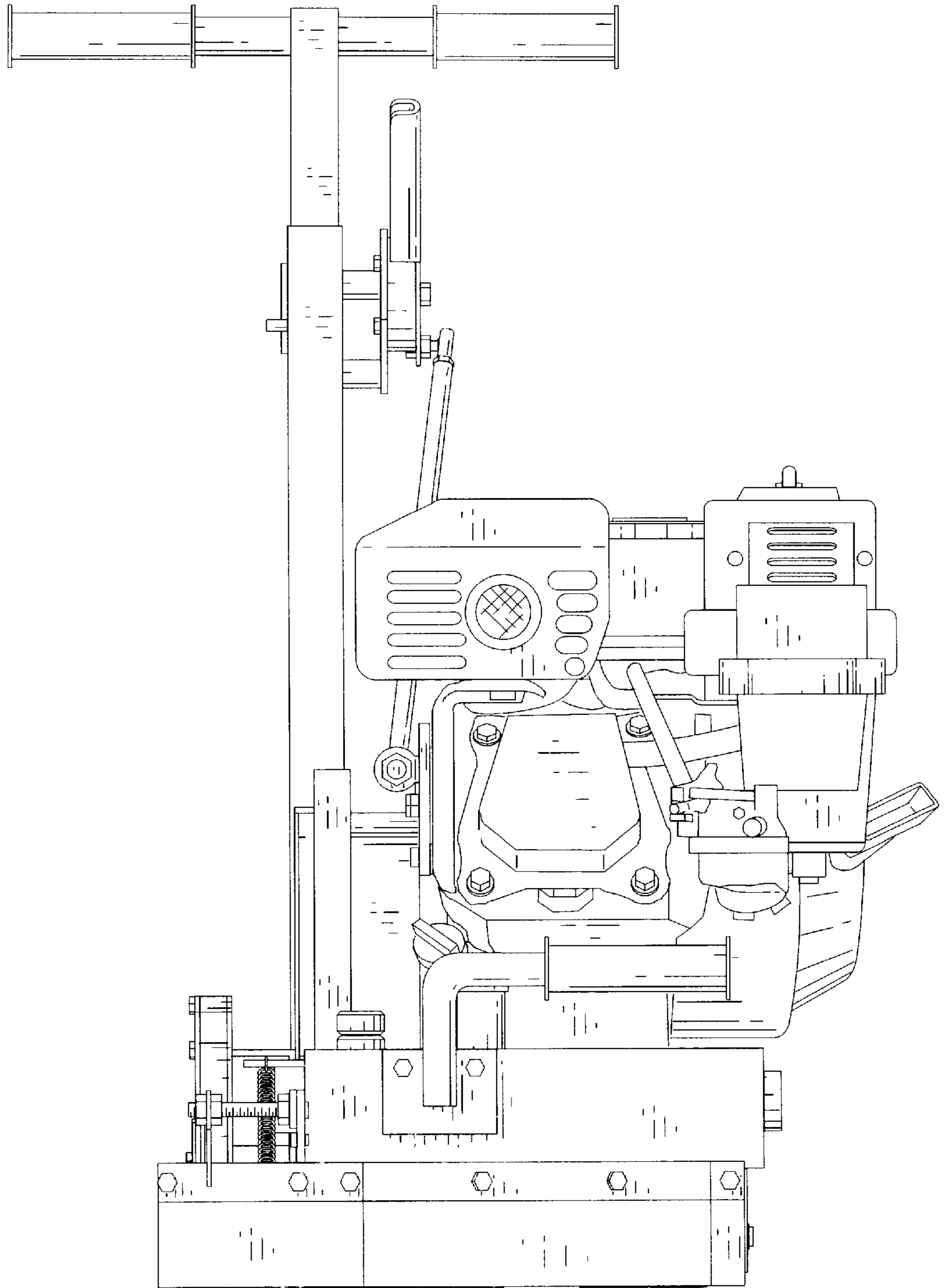

FIG. 6

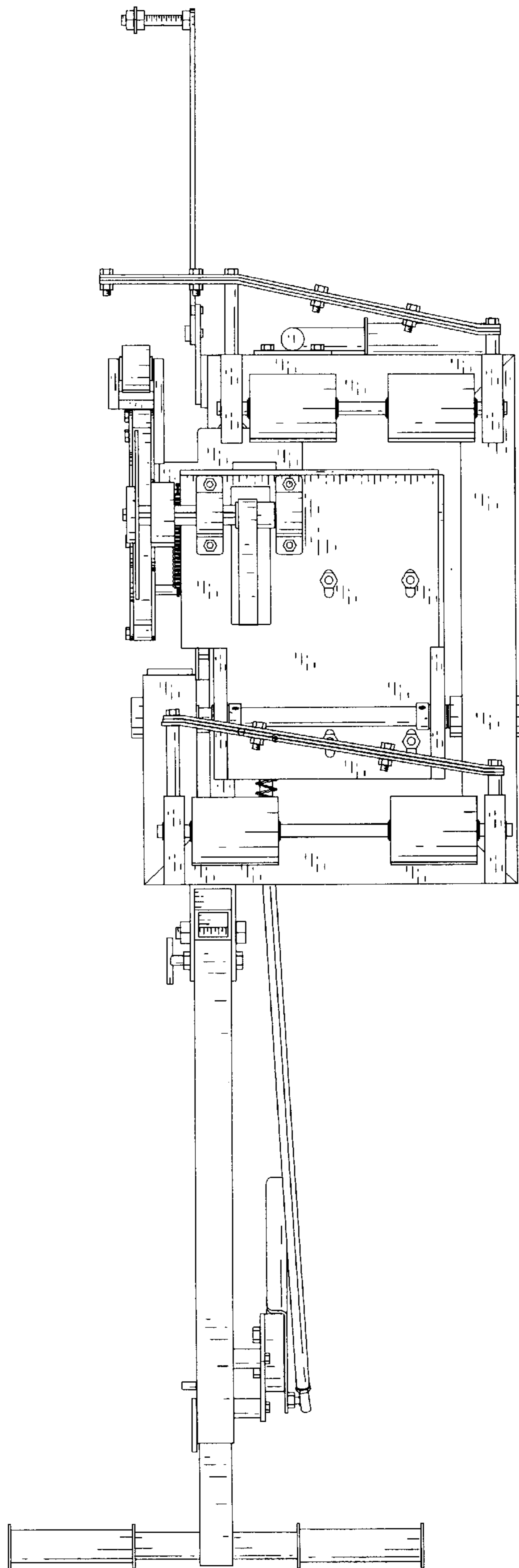

FIG. 7

