



US00D404003S

United States Patent [19]

Barbier et al.

[11] Patent Number: **Des. 404,003**

[45] Date of Patent: ****Jan. 12, 1999**

[54] **SWATH CARGO SHIP**

[75] Inventors: **Brian K. Barbier**, Berwick; **John B. Crabtree, Jr.**, Houma; **Peter W. Tsang**, Thibodaux, all of La.

[73] Assignee: **Service Marine Industries, Inc.**, Amelia, La.

[**] Term: **14 Years**

4,440,103	4/1984	Lang	114/61
4,763,596	8/1988	Yoshida	114/256
4,867,090	9/1989	Hall et al.	114/61
4,909,174	3/1990	Bowes	114/265
4,919,063	4/1990	Hall et al.	114/56
5,282,763	2/1994	Dixon	440/42
5,295,453	3/1994	Inoue	114/61
5,355,827	10/1994	Barbazash et al.	114/274
5,408,948	4/1995	Arii et al.	114/274
5,645,008	7/1997	Loui	114/274

[21] Appl. No.: **80,848**

[22] Filed: **Nov. 27, 1997**

Related U.S. Application Data

[63] Continuation-in-part of Ser. No. 755,565, Nov. 27, 1996.

[51] **LOC (6) Cl.** **12-06**

[52] **U.S. Cl.** **D12/310; D12/315**

[58] **Field of Search** **D12/300-318;**
114/61, 56, 57, 283, 292

[56] References Cited

U.S. PATENT DOCUMENTS

D. 324,845	3/1992	Kotzebue	D12/318
D. 329,418	9/1992	Jackson	D12/304
3,141,437	7/1964	Bush et al.	114/66.5
3,279,407	10/1966	Stenger	114/66.5
3,447,502	6/1969	Leopold	114/61
3,530,815	9/1970	Lewison	114/61
3,730,123	5/1973	Lang	114/66.5 H
4,174,671	11/1979	Seidl	114/61

FOREIGN PATENT DOCUMENTS

52-2987	1/1977	Japan .
57-80987	5/1982	Japan .
WO 81/00241	2/1981	WIPO .
WO 93/25431	12/1993	WIPO .

Primary Examiner—Kay H. Chin
Attorney, Agent, or Firm—Kennedy, Davis & Kennedy, PC

[57] CLAIM

The ornamental design for a swath cargo ship, as shown and described.

DESCRIPTION

FIG. 1 is a perspective view of the swath cargo ship;
FIG. 2 is a front view thereof;
FIG. 3 is a rear view thereof;
FIG. 4 is a side view thereof, the opposite being a mirror image;
FIG. 5 is a top view thereof; and,
FIG. 6 is a bottom view thereof.

1 Claim, 3 Drawing Sheets

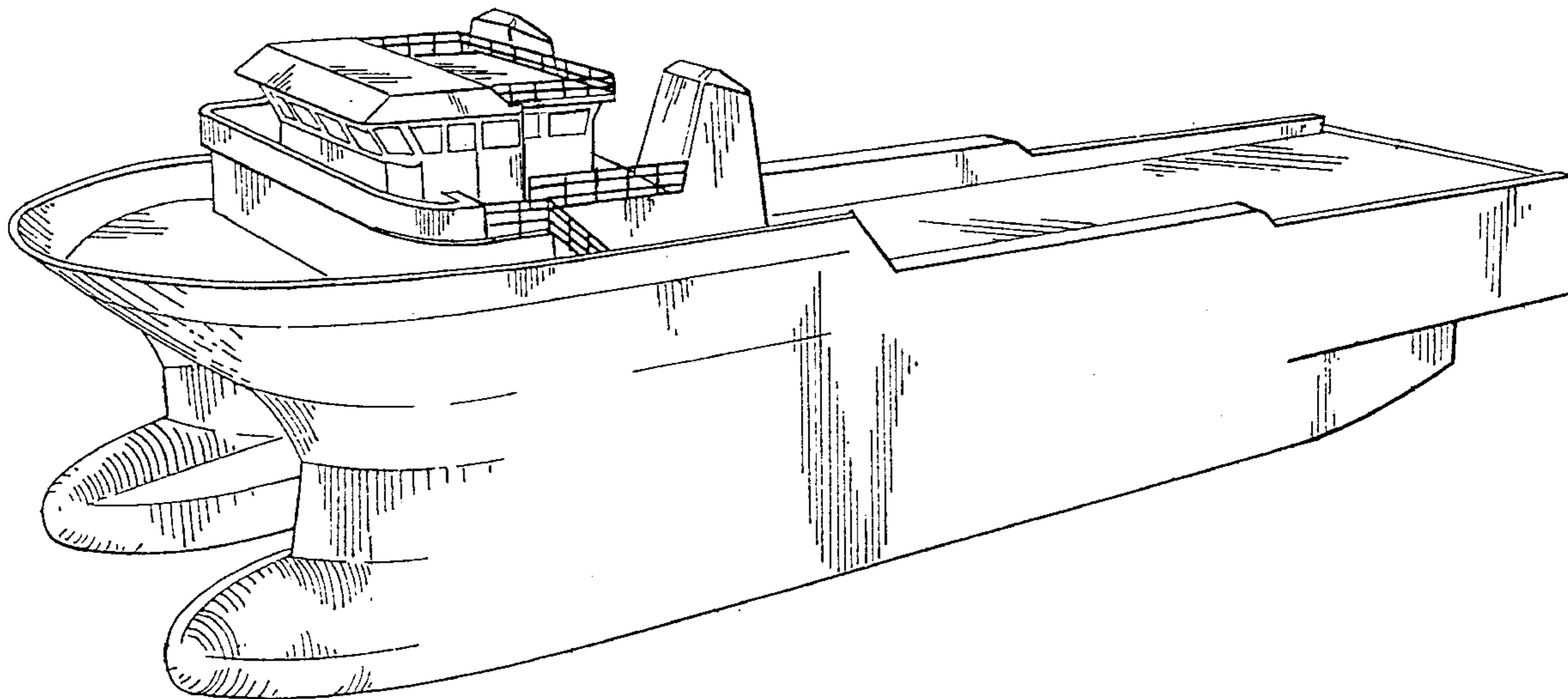

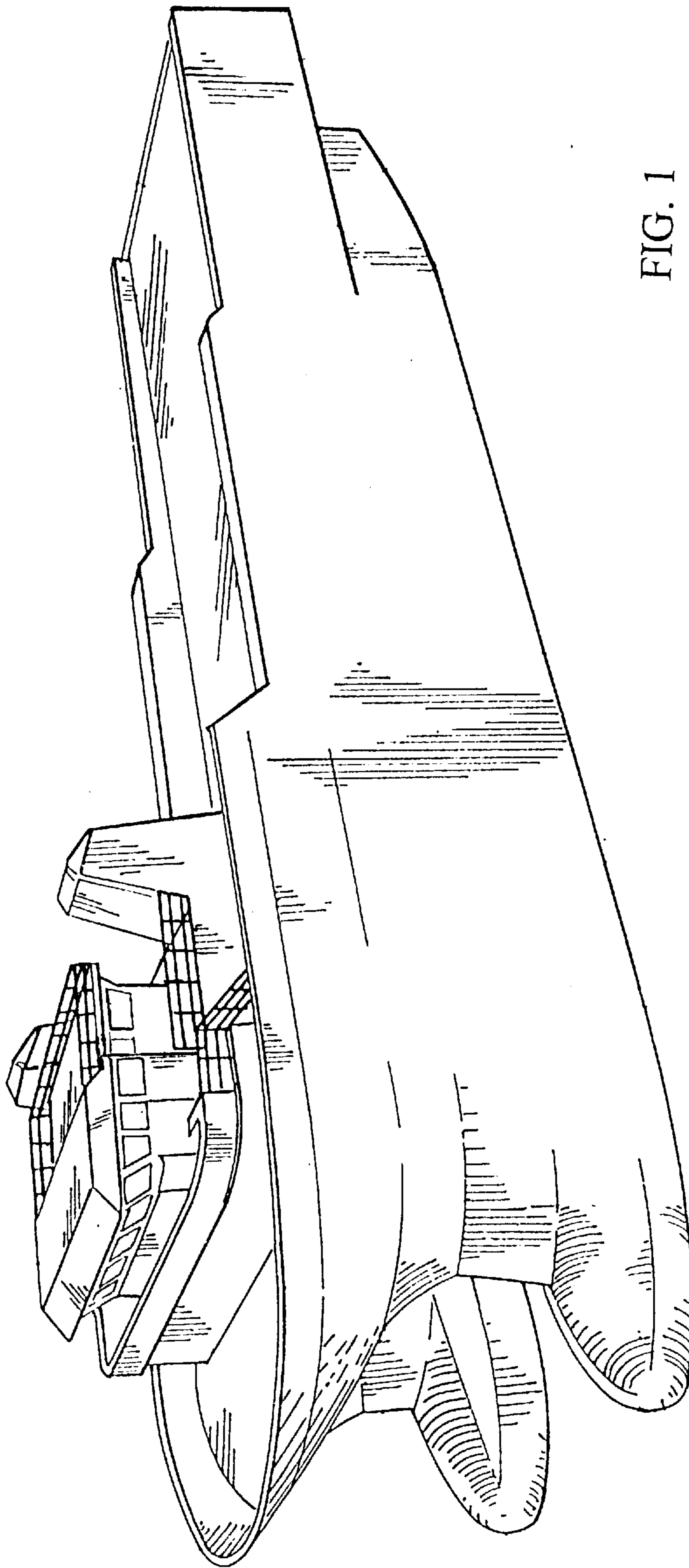

FIG. 1

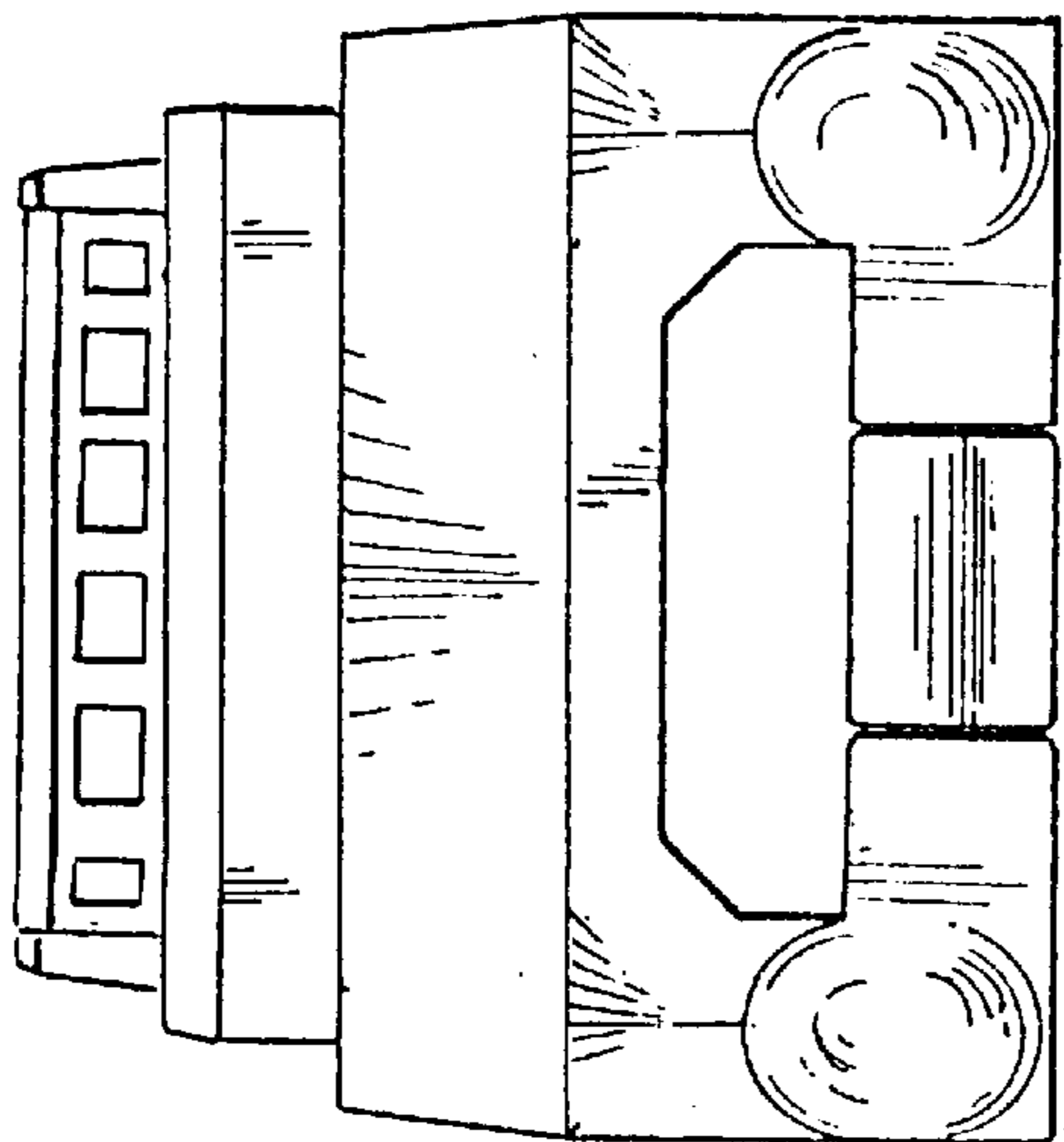

FIG. 2

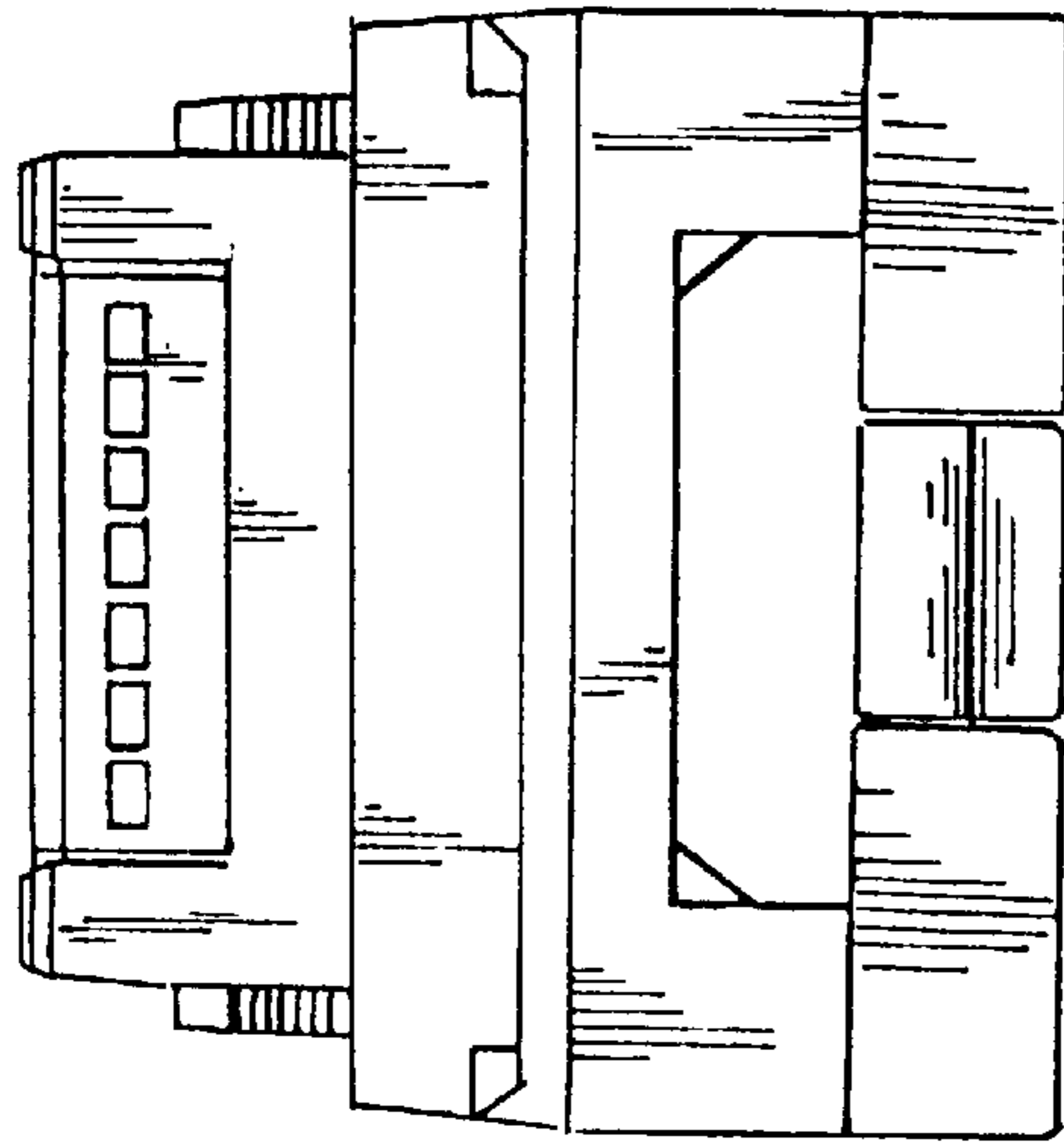

FIG. 3

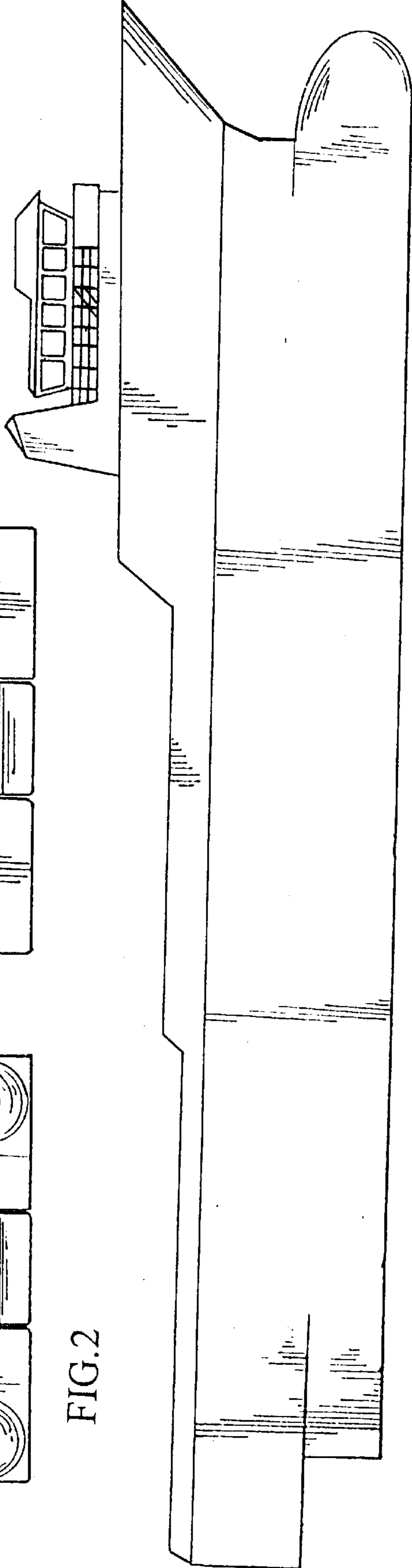

FIG. 4

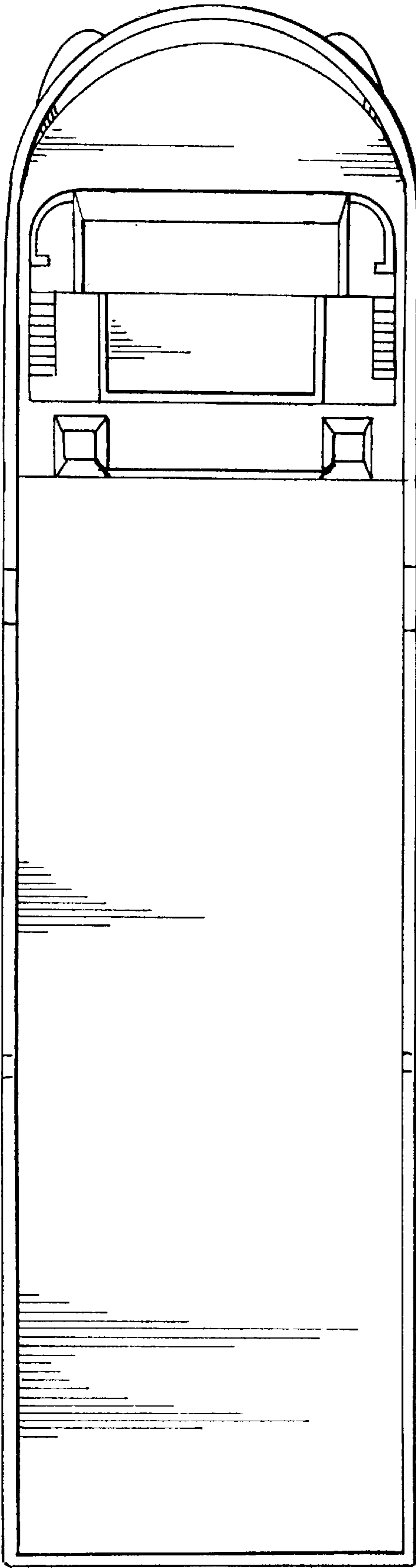

FIG. 5

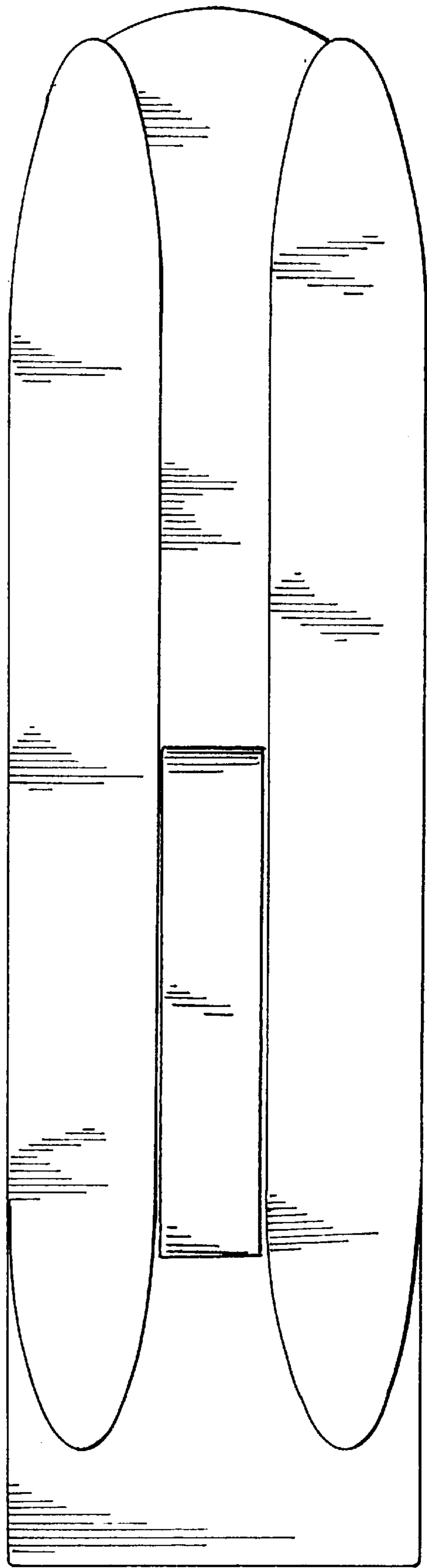

FIG. 6