



US00D403967S

**United States Patent** [19]  
**Nijs et al.**

[11] **Patent Number: Des. 403,967**

[45] **Date of Patent: \*\*Jan. 12, 1999**

[54] **UPPER PORTION OF A BOTTLE**

[75] Inventors: **Brigitte Louise Camille Nijs,**  
Kelkheim; **Heike Rasch,** Kronberg,  
both of Germany

[73] Assignee: **The Procter & Gamble Company,**  
Cincinnati, Ohio

[\*\*] Term: **14 Years**

[21] Appl. No.: **67,882**

[22] Filed: **Mar. 13, 1997**

[30] **Foreign Application Priority Data**

Sep. 18, 1996 [DE] Germany ..... M 96 08 131.7

[51] **LOC (6) Cl.** ..... **09-01**

[52] **U.S. Cl.** ..... **D9/528; D9/531**

[58] **Field of Search** ..... D9/531, 528, 536;  
215/396, 398, 385

[56] **References Cited**

**U.S. PATENT DOCUMENTS**

D. 191,722 11/1961 Lorenzen ..... D9/536

D. 214,551 7/1969 Plummer ..... D9/536  
D. 307,551 5/1990 Platte, Sr. .... D9/531  
D. 311,864 11/1990 Davis ..... D9/528  
D. 390,116 2/1998 Larkin et al. .... D9/528

*Primary Examiner*—Lucy Lieberman  
*Attorney, Agent, or Firm*—Jack L. Oney, Jr.

[57] **CLAIM**

The ornamental design for an upper portion of a bottle, as shown and described.

**DESCRIPTION**

FIG. 1 is a top view of an upper portion of a bottle, embodying our new design;

FIG. 2 is a front elevational view thereof;

FIG. 3 is a side elevational view thereof, the opposite side elevational view thereof being a mirror image; and

FIG. 4 is a rear elevational view thereof.

The broken lines shown in the figures are for illustrative purposes only, and form no part of the claimed invention.

**1 Claim, 1 Drawing Sheet**

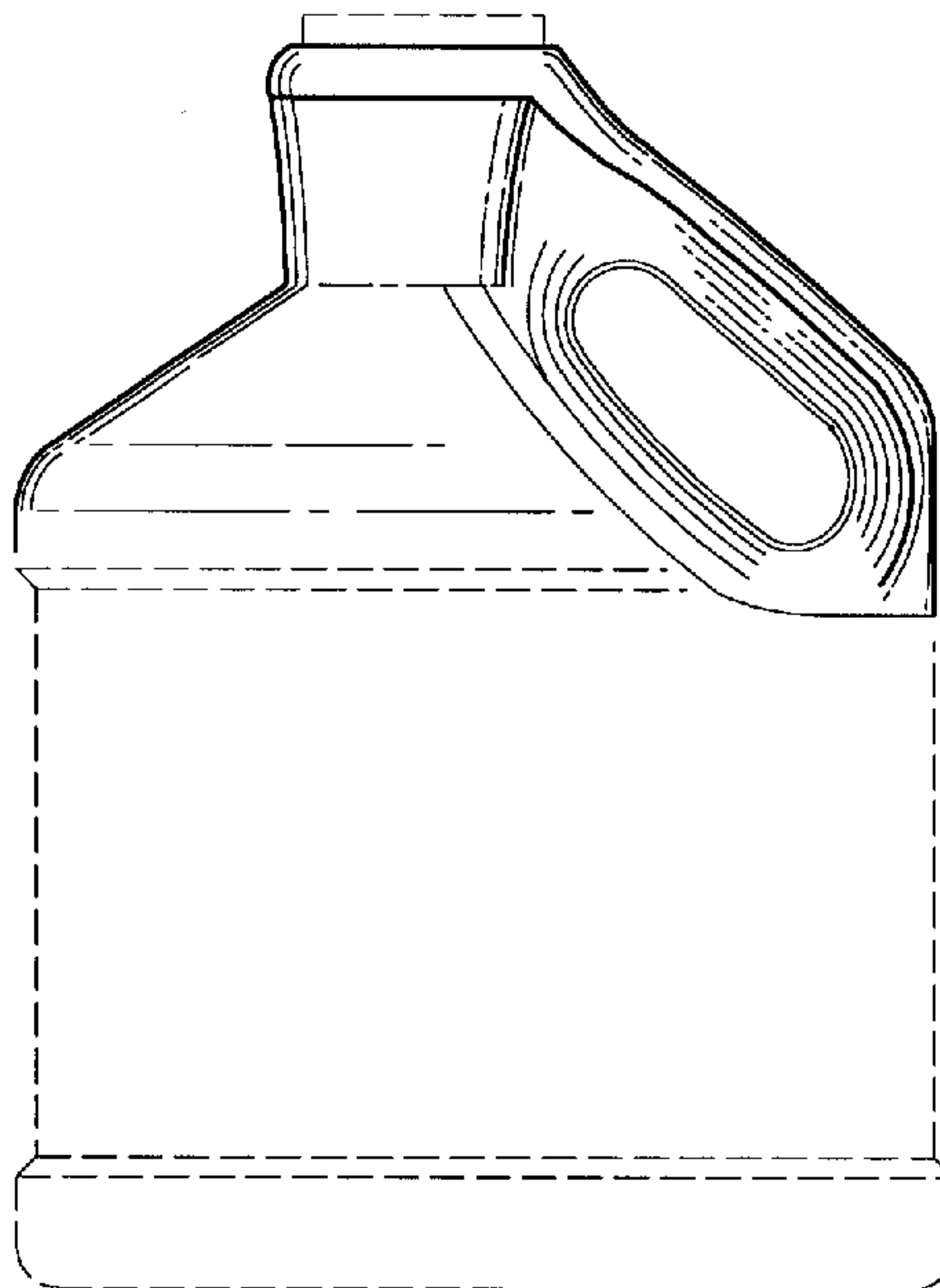

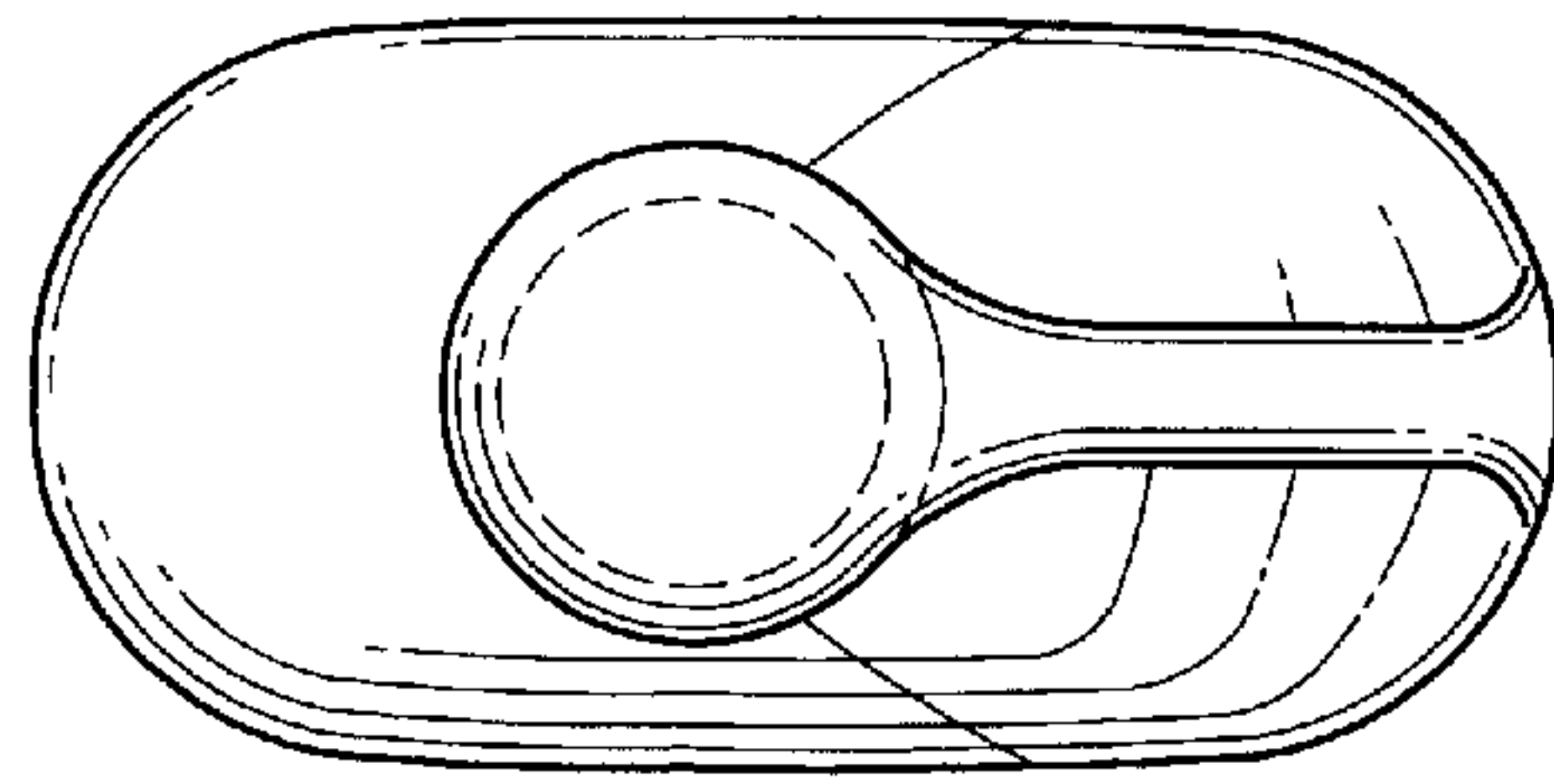

Fig. 1

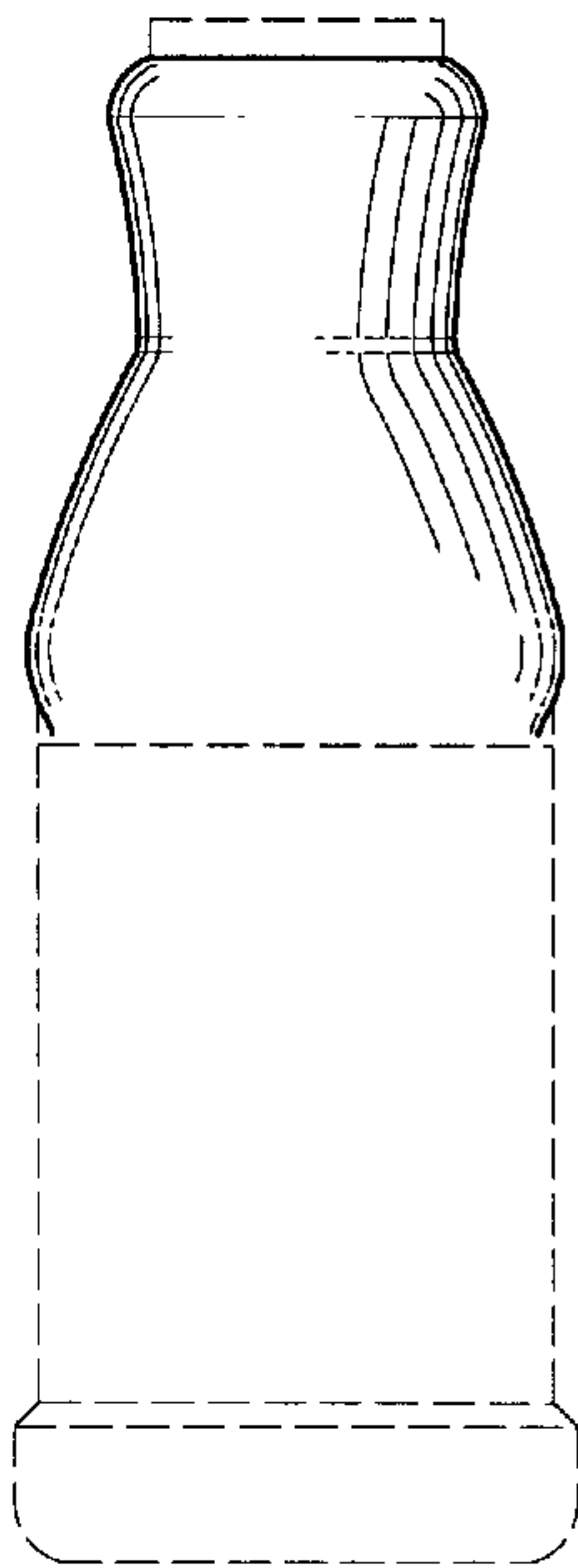

Fig. 2

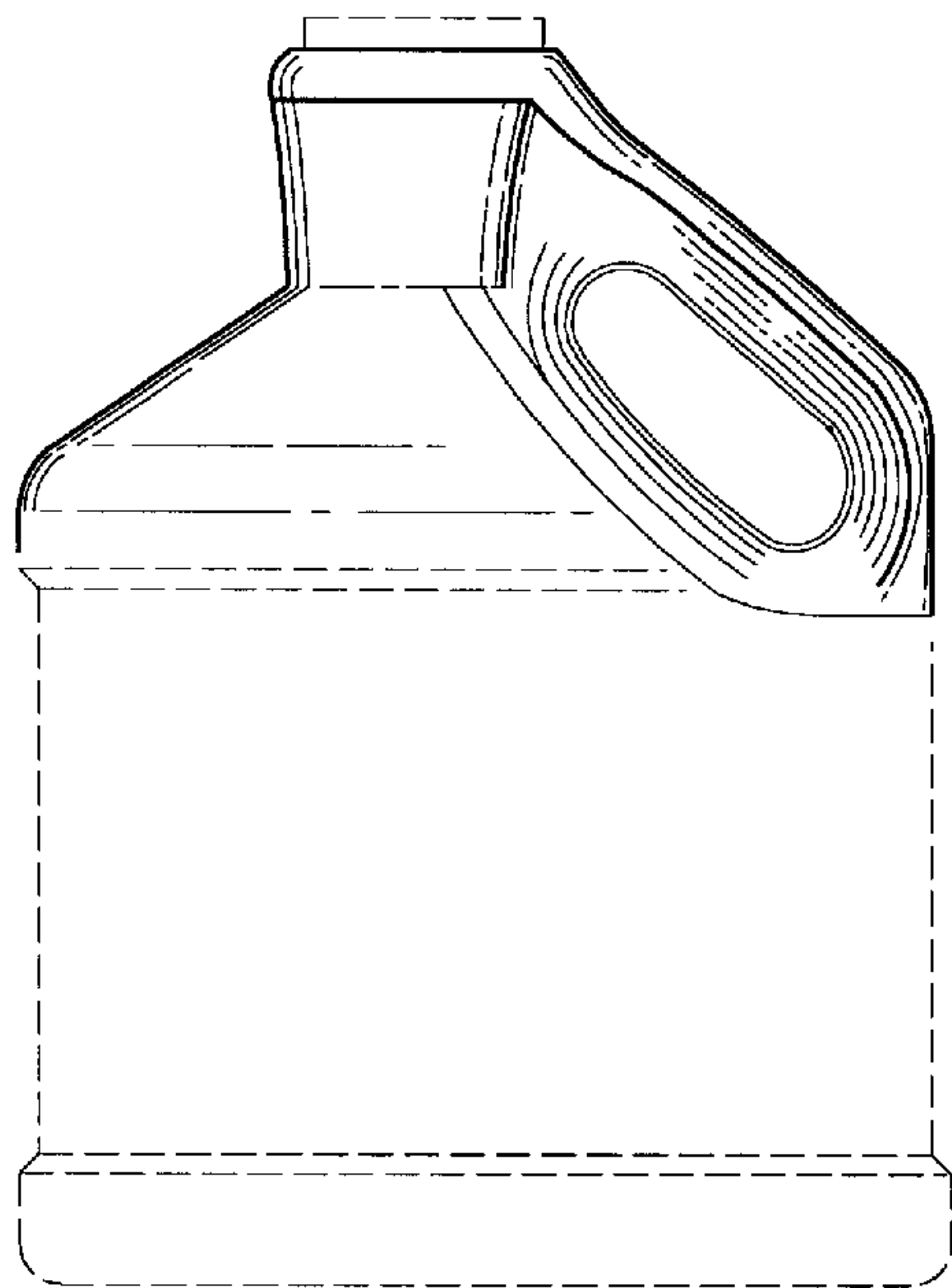

Fig. 3

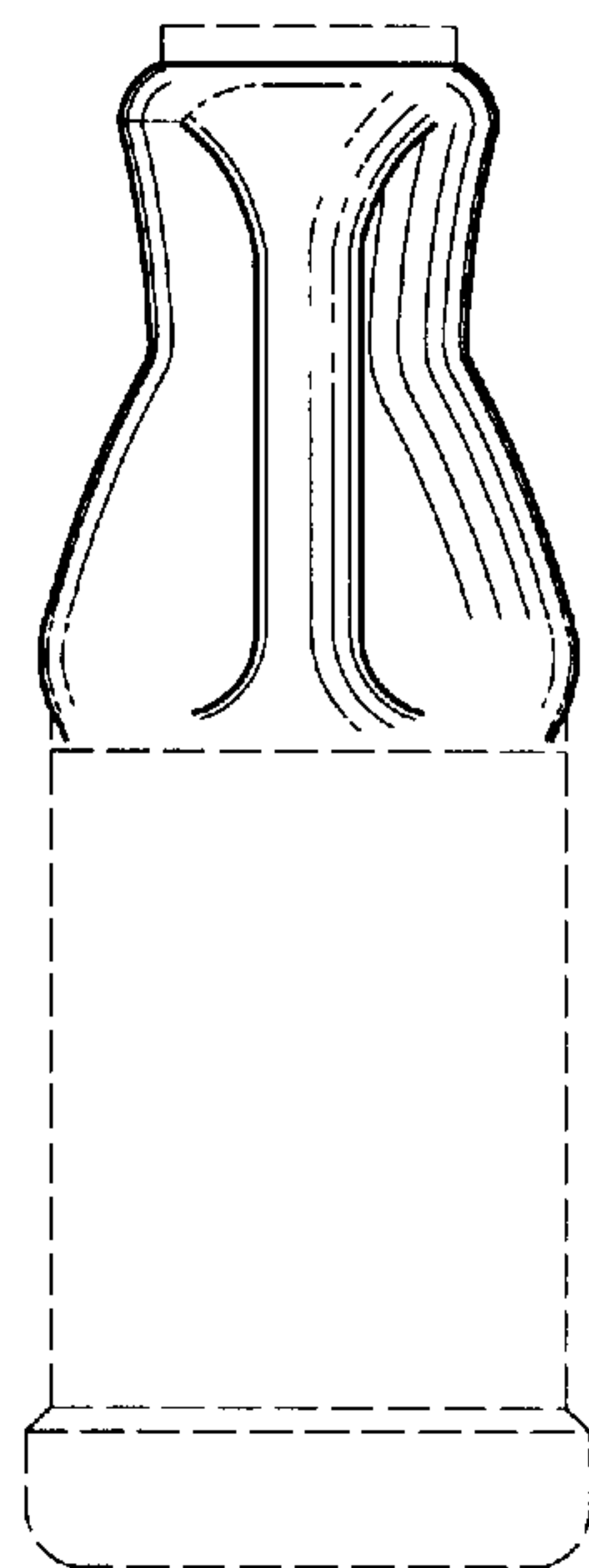

Fig. 4