



US00D403685S

United States Patent [19]

Kobayashi et al.

[11] Patent Number: Des. 403,685

[45] Date of Patent: **Jan. 5, 1999

[54] WIRE SAW HOUSING

[75] Inventors: **Shigeo Kobayashi; Yasuhiro Ito**, both of Yokohama, Japan

[73] Assignee: **Nippei Toyama Corporation**, Tokyo, Japan

[**] Term: **14 Years**

[21] Appl. No.: **64,300**

[22] Filed: **Mar. 20, 1997**

[30] Foreign Application Priority Data

Jun. 28, 1996	[JP]	Japan	8-19227
Dec. 6, 1996	[JP]	Japan	8-37121
Dec. 6, 1996	[JP]	Japan	8-37122
Dec. 6, 1996	[JP]	Japan	8-37123
Dec. 6, 1996	[JP]	Japan	8-37124
Dec. 6, 1996	[JP]	Japan	8-37125
Dec. 6, 1996	[JP]	Japan	8-37126
Dec. 6, 1996	[JP]	Japan	8-37127
Dec. 6, 1996	[JP]	Japan	8-37128
Dec. 6, 1996	[JP]	Japan	8-37129
Dec. 6, 1996	[JP]	Japan	8-37130
Dec. 6, 1996	[JP]	Japan	8-37131
Dec. 6, 1996	[JP]	Japan	8-37132
Dec. 6, 1996	[JP]	Japan	8-37133

[51] LOC (6) Cl. **15-09**

[52] U.S. Cl. **D15/133**

[58] Field of Search D15/133; 83/651.1, 83/387.1, 785, 788; 125/12, 21, 16.01, 22; 451/296, 526

[56] References Cited

U.S. PATENT DOCUMENTS

D. 336,749 6/1993 Lenard et al. D15/133 X

Primary Examiner—Antoine Duval Davis
Attorney, Agent, or Firm—Stetina Brunda Garred & Brucker

[57] CLAIM

The ornamental design for a wire saw housing, as shown and described.

DESCRIPTION

FIG. 1 is a front elevational view of a wire saw housing;

FIG. 2 is a rear elevational view thereof;
 FIG. 3 is a bottom plan view thereof;
 FIG. 4 is a top plan view thereof;
 FIG. 5 is a right side elevational view thereof;
 FIG. 6 is a left side elevational view thereof;
 FIG. 7 is a front perspective view thereof;
 FIG. 8 is a rear perspective view thereof; and
 FIG. 9 is a front perspective view thereof with the front doors opened;
 FIG. 10 is a front elevational view of a second embodiment of the wire saw housing;
 FIG. 11 is a rear elevational view thereof;
 FIG. 12 is a top plan view thereof;
 FIG. 13 is a bottom plan view thereof;
 FIG. 14 is a right side elevational view thereof;
 FIG. 15 is a left side elevational view thereof;
 FIG. 16 is a front perspective view thereof;
 FIG. 17 is a rear perspective view thereof; and
 FIG. 18 is a front perspective view thereof with the front doors opened;
 FIG. 19 is a front elevational view of a third embodiment of the wire saw housing;
 FIG. 20 is a rear elevational view thereof;
 FIG. 21 is a top plan view thereof;
 FIG. 22 is a bottom plan view thereof;
 FIG. 23 is a right side elevational view thereof;
 FIG. 24 is a left side elevational view thereof;
 FIG. 25 is a front perspective view thereof;
 FIG. 26 is a rear perspective view thereof; and
 FIG. 27 is a front perspective view thereof with the front doors opened;
 FIG. 28 is a front elevational view of a fourth embodiment of the wire saw housing;
 FIG. 29 is a rear elevational view thereof;
 FIG. 30 is a top plan view thereof;
 FIG. 31 is a bottom plan view thereof;
 FIG. 32 is a right side elevational view thereof;
 FIG. 33 is a left side elevational view thereof;
 FIG. 34 is a front perspective view thereof;
 FIG. 35 is a rear perspective view thereof; and
 FIG. 36 is a front perspective view of a thereof with the front doors opened;
 FIG. 37 is a front elevational view of a fifth embodiment of the wire saw housing;

(List continued on next page.)

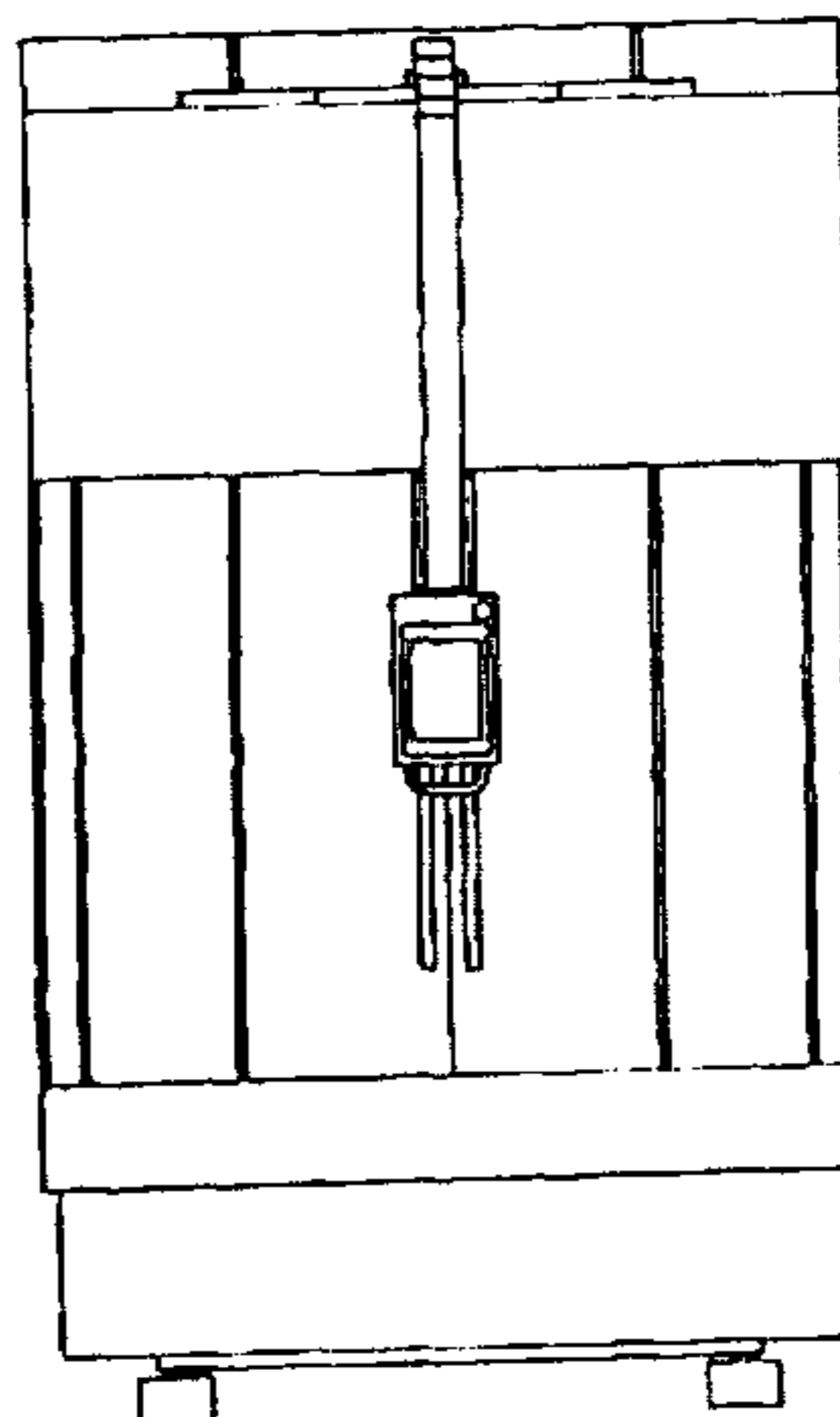

DESCRIPTION

FIG. 38 is a rear elevational view thereof;
 FIG. 39 is a top plan view thereof;
 FIG. 40 is a bottom plan view thereof;
 FIG. 41 is a right side elevational view thereof, the left side elevational view being a mirror image of FIG. 41;
 FIG. 42 is a front perspective view thereof;
 FIG. 43 is a rear perspective view thereof; and
 FIG. 44 is a front perspective view thereof with the front doors opened;
 FIG. 45 is a front elevational view of a sixth embodiment of the wire saw housing;
 FIG. 46 is a rear elevational view thereof;
 FIG. 47 is a top plan view thereof;
 FIG. 48 is a bottom plan view thereof;
 FIG. 49 is a right side elevational view thereof;
 FIG. 50 is a left side elevational view thereof;
 FIG. 51 is a front perspective view thereof;
 FIG. 52 is a rear perspective view thereof; and
 FIG. 53 is a front perspective view thereof with the front doors opened;
 FIG. 54 is a front elevational view of a seventh embodiment of the wire saw housing;
 FIG. 55 is a rear elevational view thereof;
 FIG. 56 is a top plan view thereof;
 FIG. 57 is a bottom plan view thereof;
 FIG. 58 is a right side elevational view thereof;
 FIG. 59 is a left side elevational view thereof;
 FIG. 60 is a front perspective view thereof;
 FIG. 61 is a rear perspective view thereof; and
 FIG. 62 is a front perspective view thereof with the front doors opened;
 FIG. 63 is a front elevational view of a eighth embodiment of the wire saw housing;
 FIG. 64 is a rear elevational view thereof;
 FIG. 65 is a top plan view thereof;
 FIG. 66 is a bottom plan view thereof;
 FIG. 67 is a right side elevational view thereof;
 FIG. 68 is a left side elevational view thereof;
 FIG. 69 is a front perspective view thereof;
 FIG. 70 is a rear perspective view thereof; and
 FIG. 71 is a front perspective view thereof with the front doors opened;
 FIG. 72 is a front elevational view of a ninth embodiment of the wire saw housing;
 FIG. 73 is a rear elevational view thereof;
 FIG. 74 is a top plan view thereof;
 FIG. 75 is a bottom plan view thereof;
 FIG. 76 is a right side elevational view thereof, the left side elevational view being a mirror image of FIG. 76;
 FIG. 77 is a front perspective view thereof;
 FIG. 78 is a rear perspective view thereof; and
 FIG. 79 is a front perspective view thereof with the front doors opened;
 FIG. 80 is a front elevational view of a tenth embodiment of the wire saw housing;

FIG. 81 is a rear elevational view thereof;
 FIG. 82 is a top plan view thereof;
 FIG. 83 is a bottom plan view thereof;
 FIG. 84 is a right side elevational view thereof;
 FIG. 85 is a left side elevational view thereof;
 FIG. 86 is a front perspective view thereof;
 FIG. 87 is a rear perspective view thereof; and
 FIG. 88 is a front perspective view thereof with the front doors opened;
 FIG. 89 is a front elevational view of a eleventh embodiment of the wire saw housing;
 FIG. 90 is a rear elevational view thereof;
 FIG. 91 is a top plan view thereof;
 FIG. 92 is a bottom plan view thereof;
 FIG. 93 is a right side elevational view thereof;
 FIG. 94 is a left side elevational view thereof;
 FIG. 95 is a front perspective view thereof;
 FIG. 96 is a rear perspective view thereof; and
 FIG. 97 is a front perspective view thereof with the front doors opened;
 FIG. 98 is a front elevational view of a twelfth embodiment of the wire saw housing;
 FIG. 99 is a rear elevational view thereof;
 FIG. 100 is a top plan view thereof;
 FIG. 101 is a bottom plan view thereof;
 FIG. 102 is a right side elevational view thereof;
 FIG. 103 is a left side elevational view thereof;
 FIG. 104 is a front perspective view thereof;
 FIG. 105 is a rear perspective view thereof; and
 FIG. 106 is a front perspective view thereof with the front doors opened;
 FIG. 107 is a front elevational view of a thirteenth embodiment of the wire saw housing;
 FIG. 108 is a rear elevational view thereof;
 FIG. 109 is a top plan view thereof;
 FIG. 110 is a bottom plan view thereof;
 FIG. 111 is a right side elevational view thereof;
 FIG. 112 is a left side elevational view thereof;
 FIG. 113 is a front perspective view thereof;
 FIG. 114 is a rear perspective view thereof; and
 FIG. 115 is a front perspective view thereof with the front doors opened;
 FIG. 116 is a front elevational view of a fourteenth embodiment of the wire saw housing;
 FIG. 117 is a rear elevational view thereof;
 FIG. 118 is a top plan view thereof;
 FIG. 119 is a bottom plan view thereof;
 FIG. 120 is a right side elevational view thereof;
 FIG. 121 is a left side elevational view thereof;
 FIG. 122 is a front perspective view thereof;
 FIG. 123 is a rear perspective view thereof; and
 FIG. 124 is a front perspective view thereof with the front doors opened.

Fig. 1

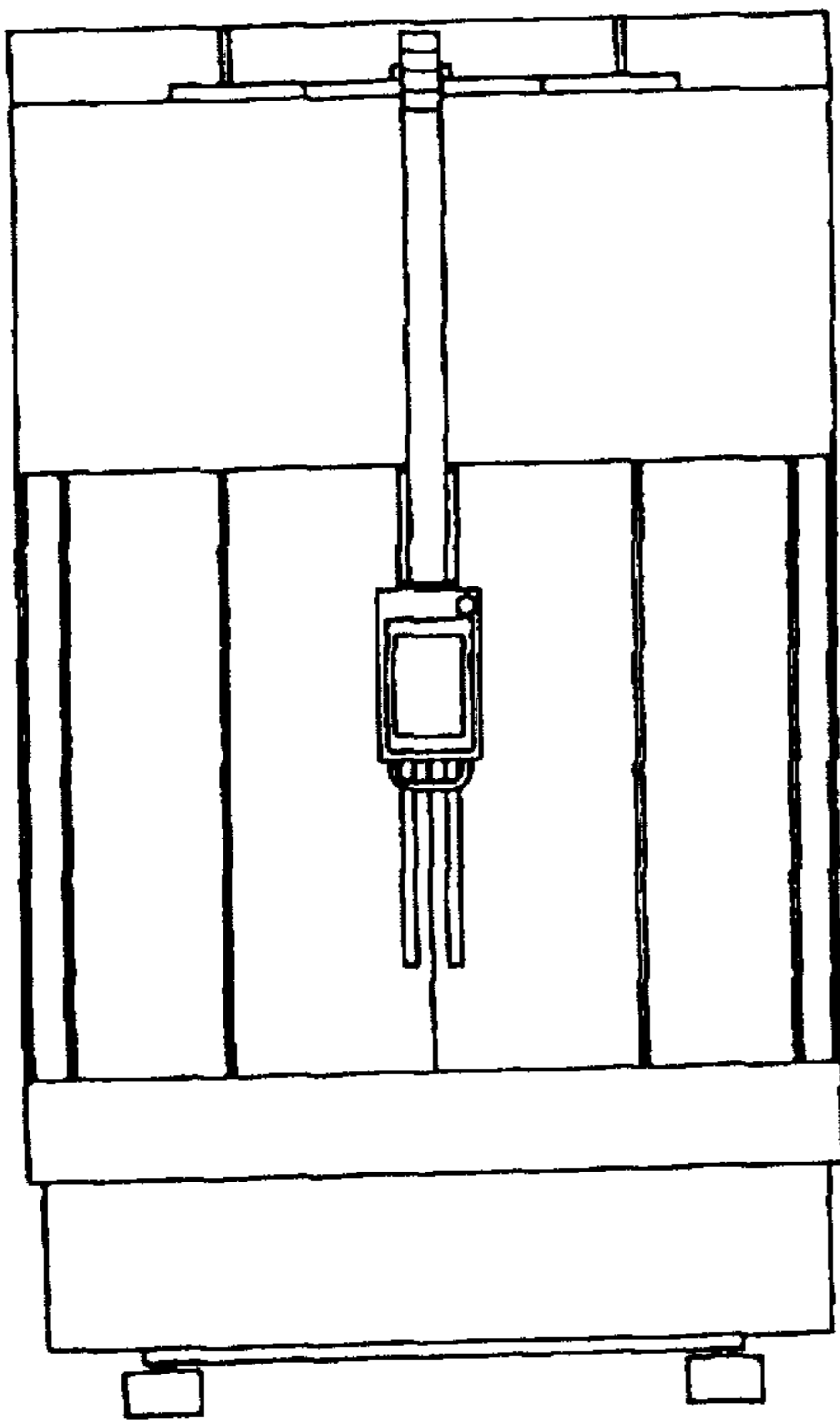

Fig. 2

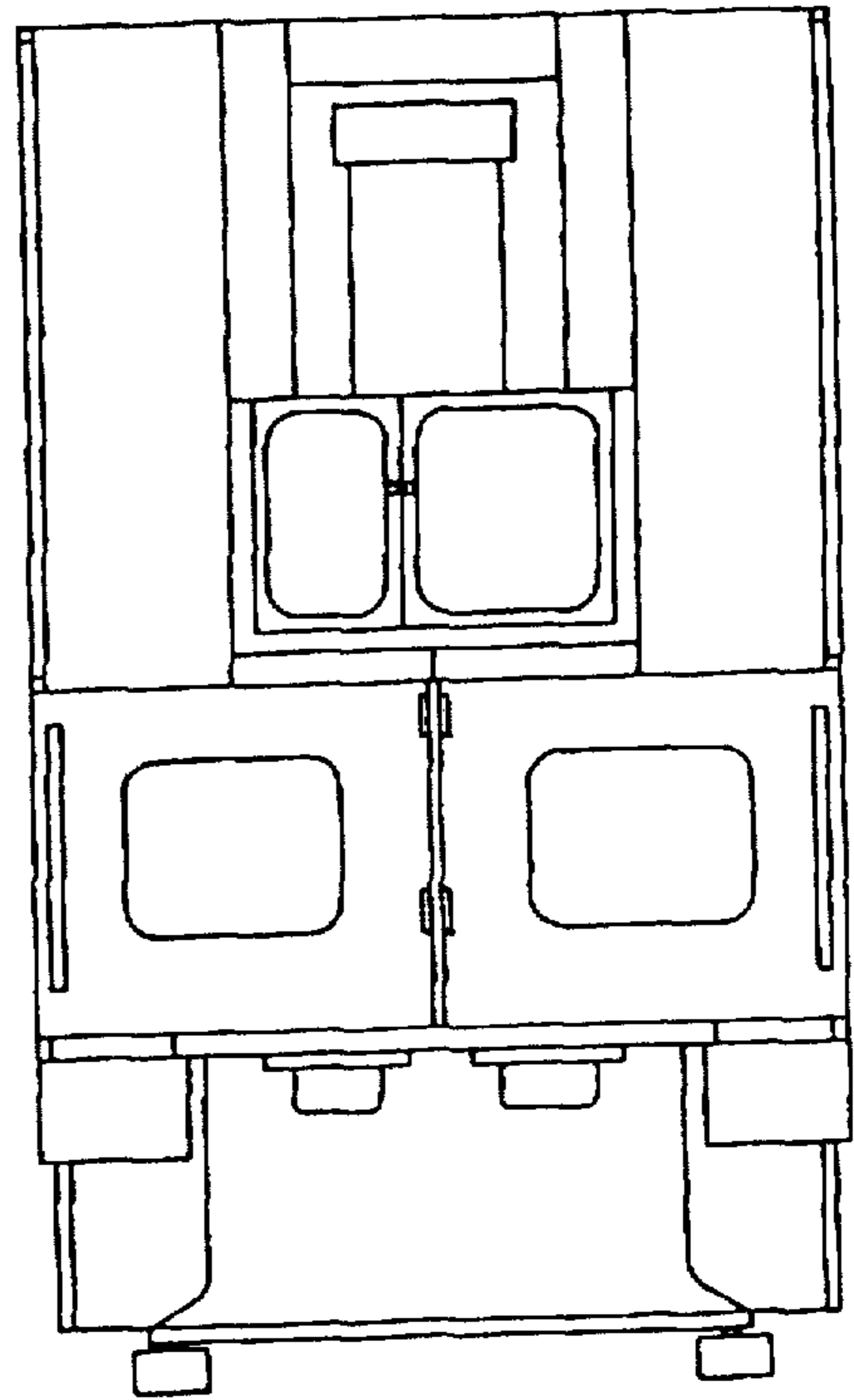

Fig. 3

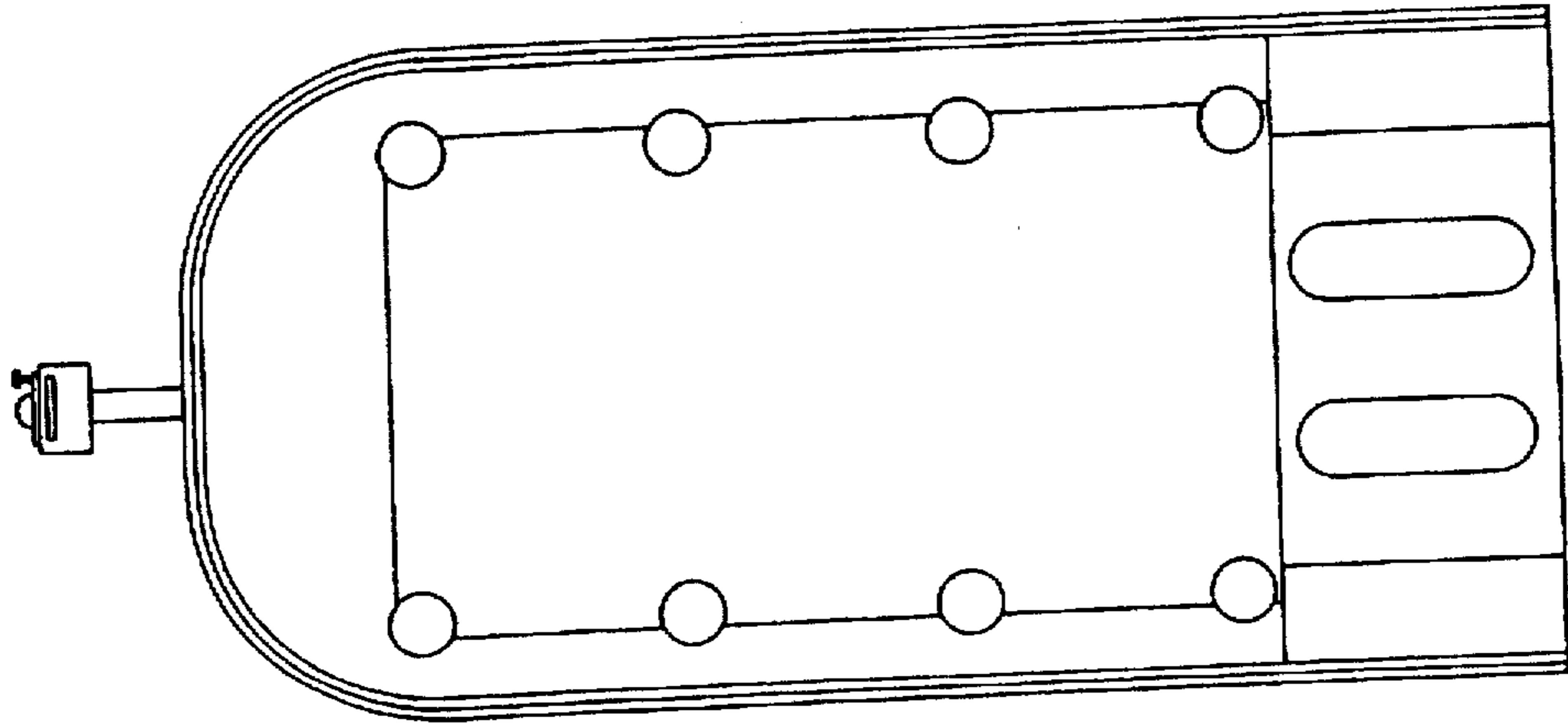

Fig. 4

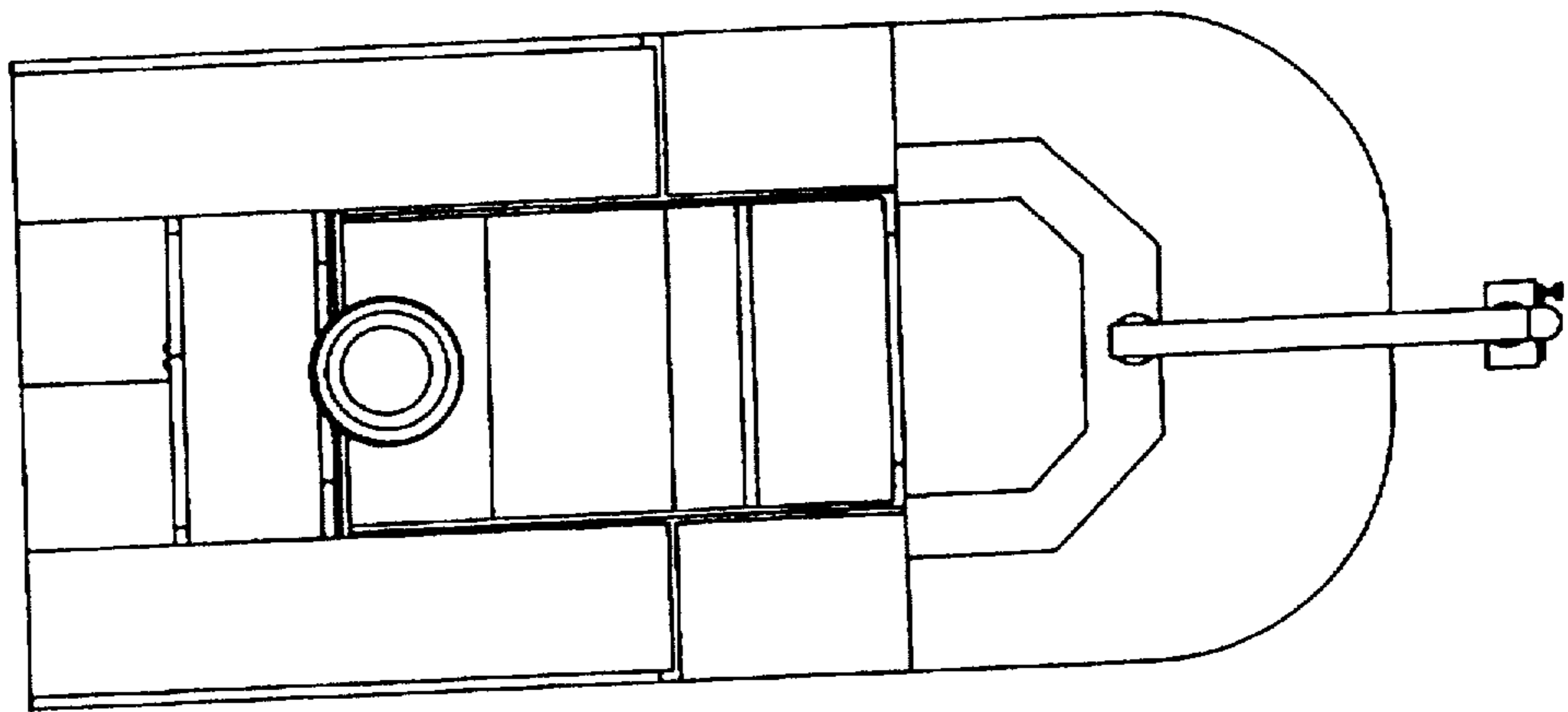

Fig. 5

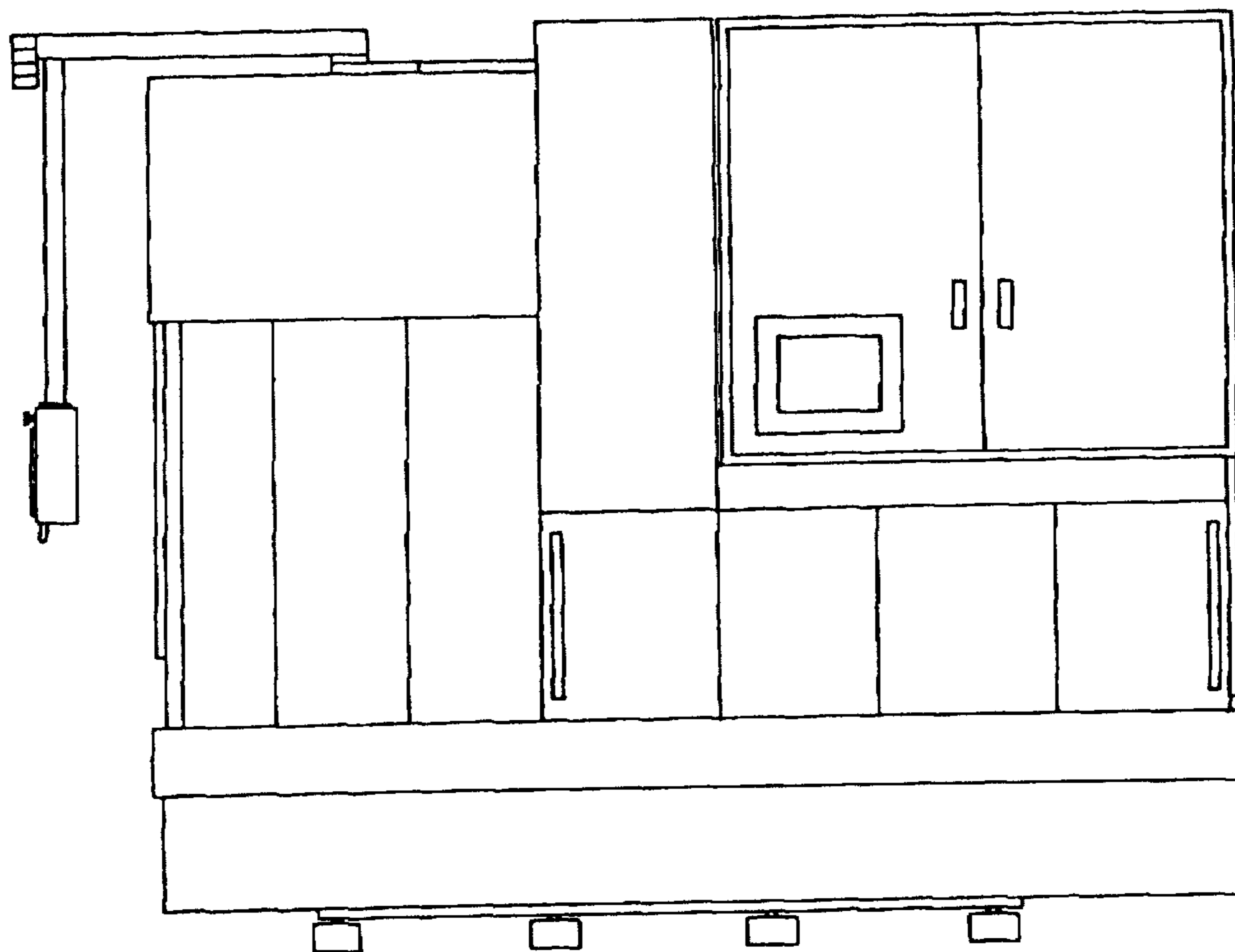

Fig. 6

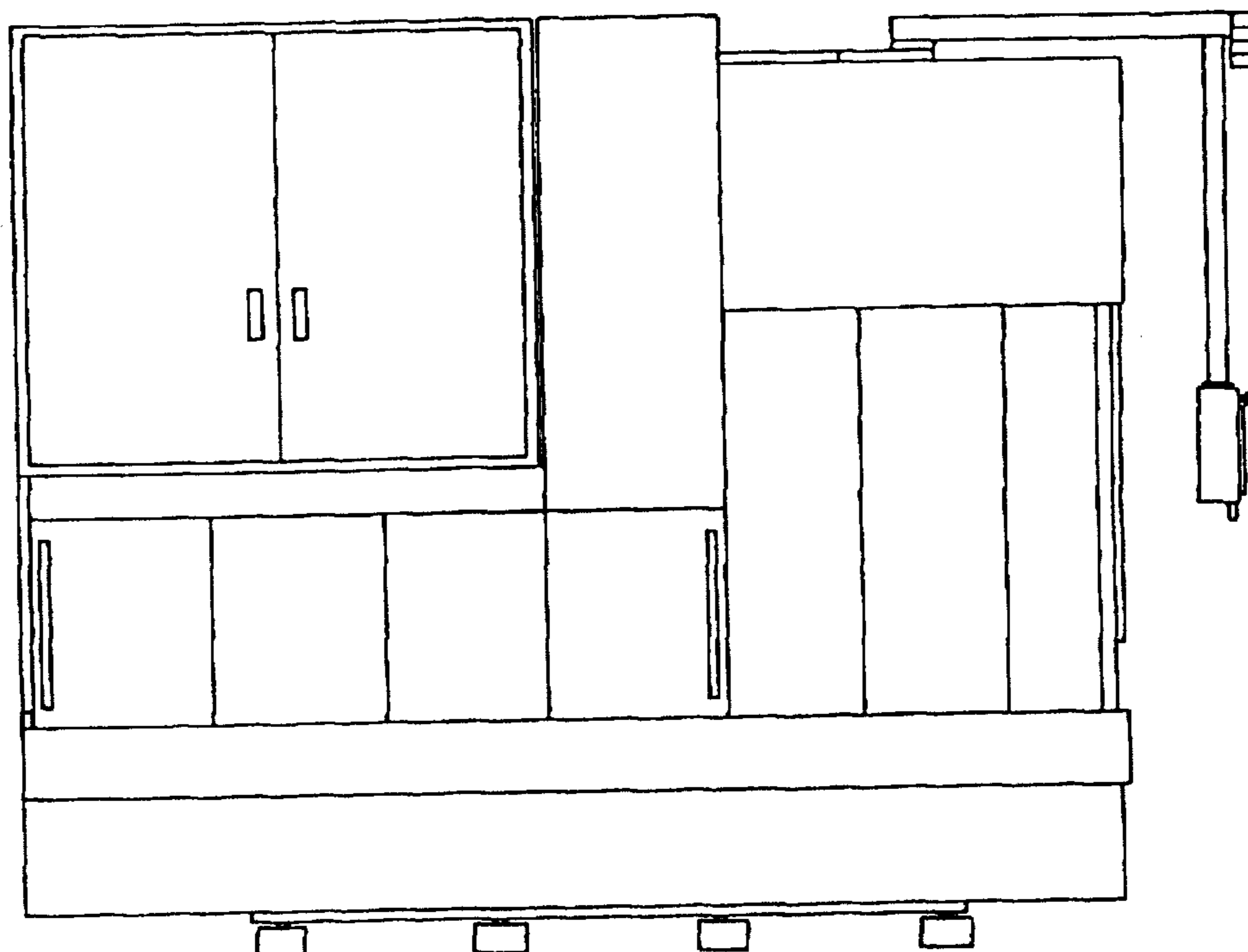

Fig. 7

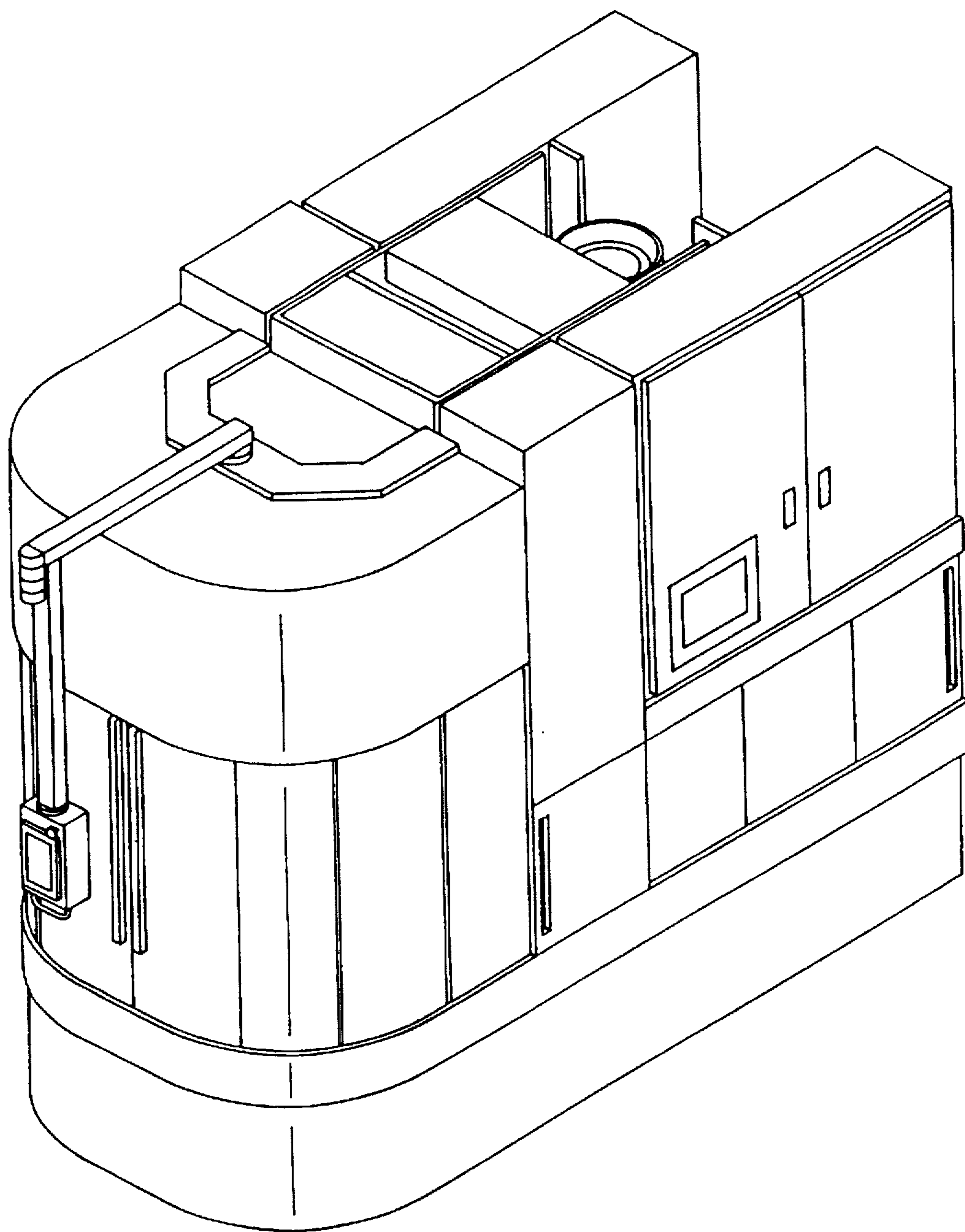

Fig. 8

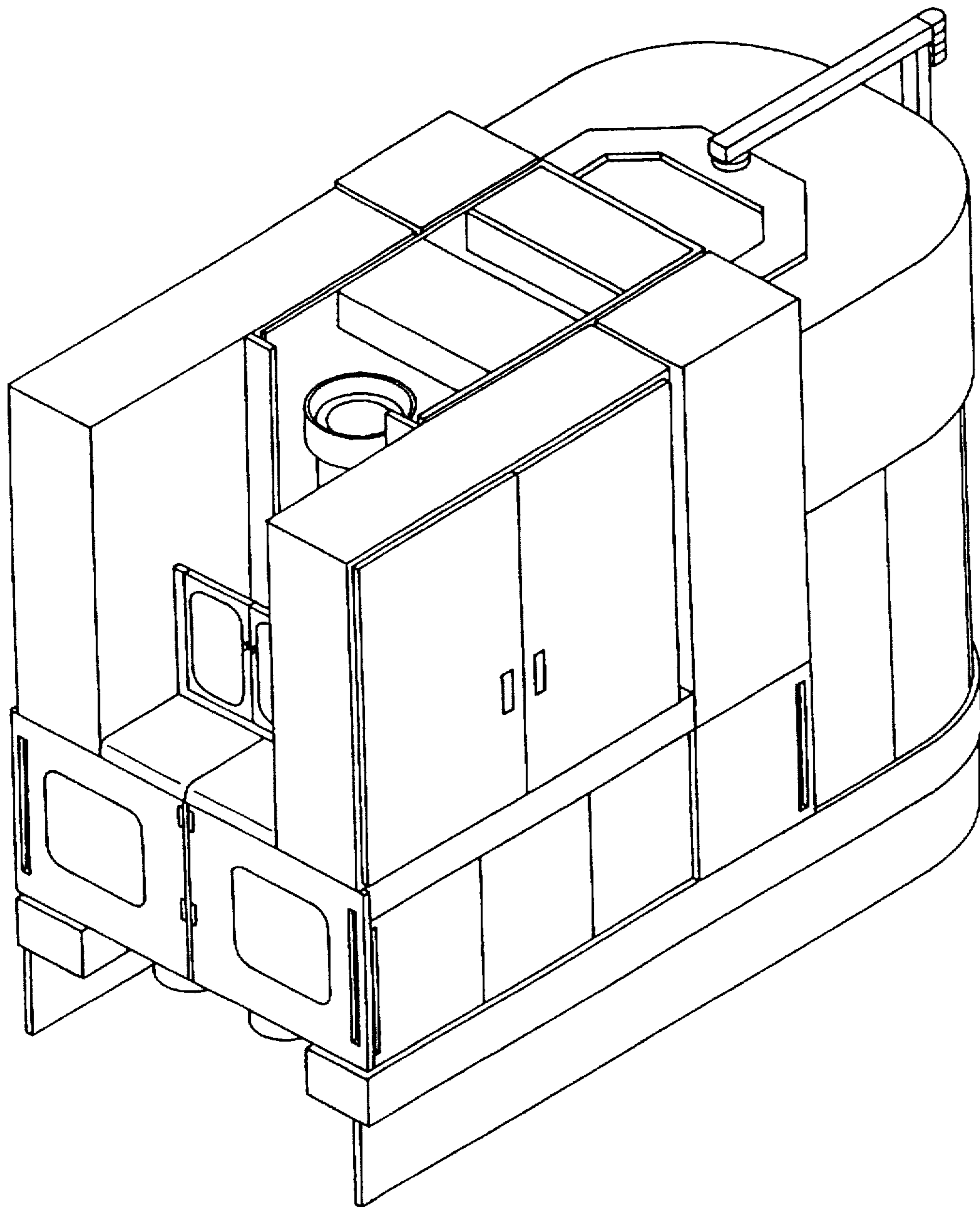

Fig. 9

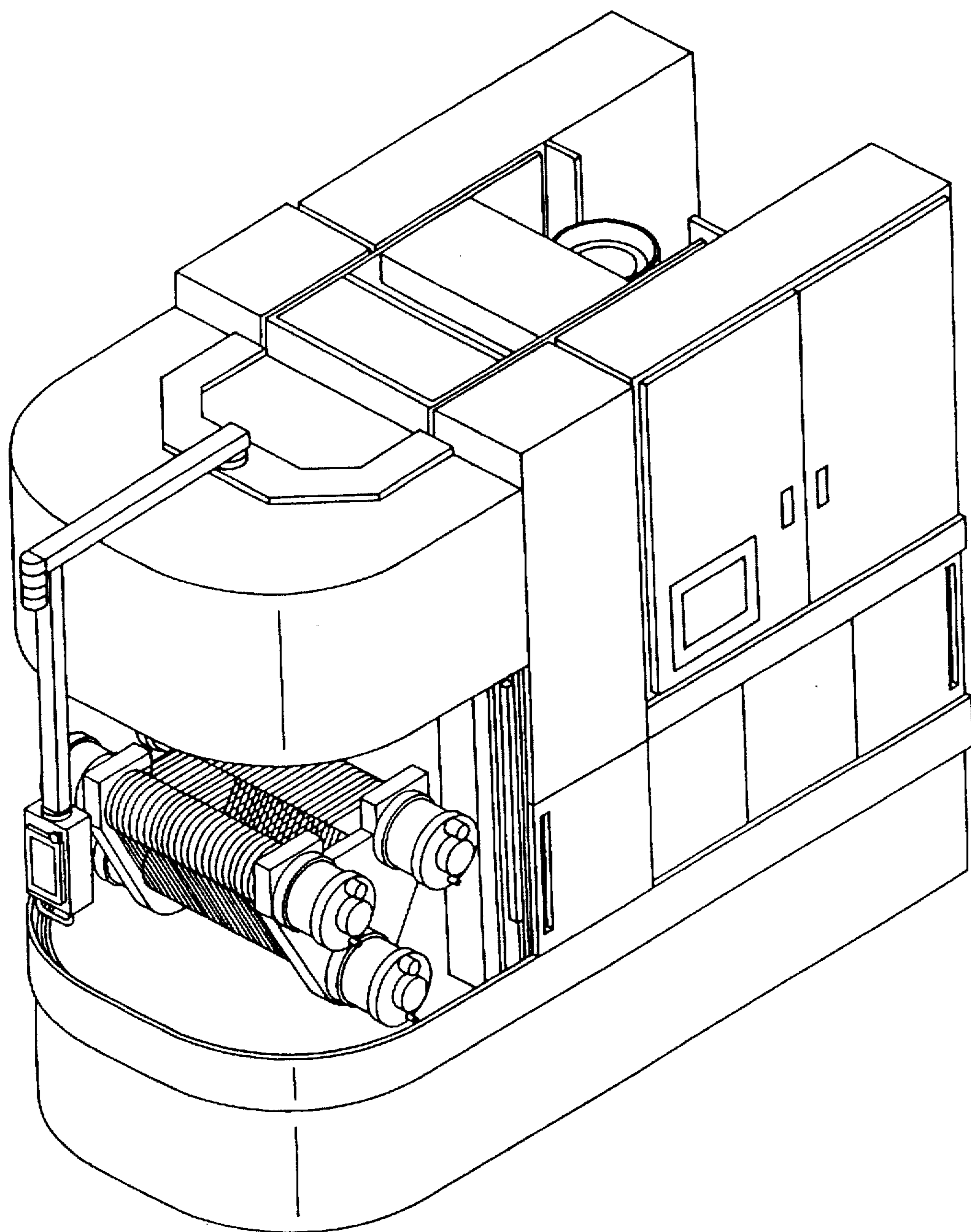

Fig. 10

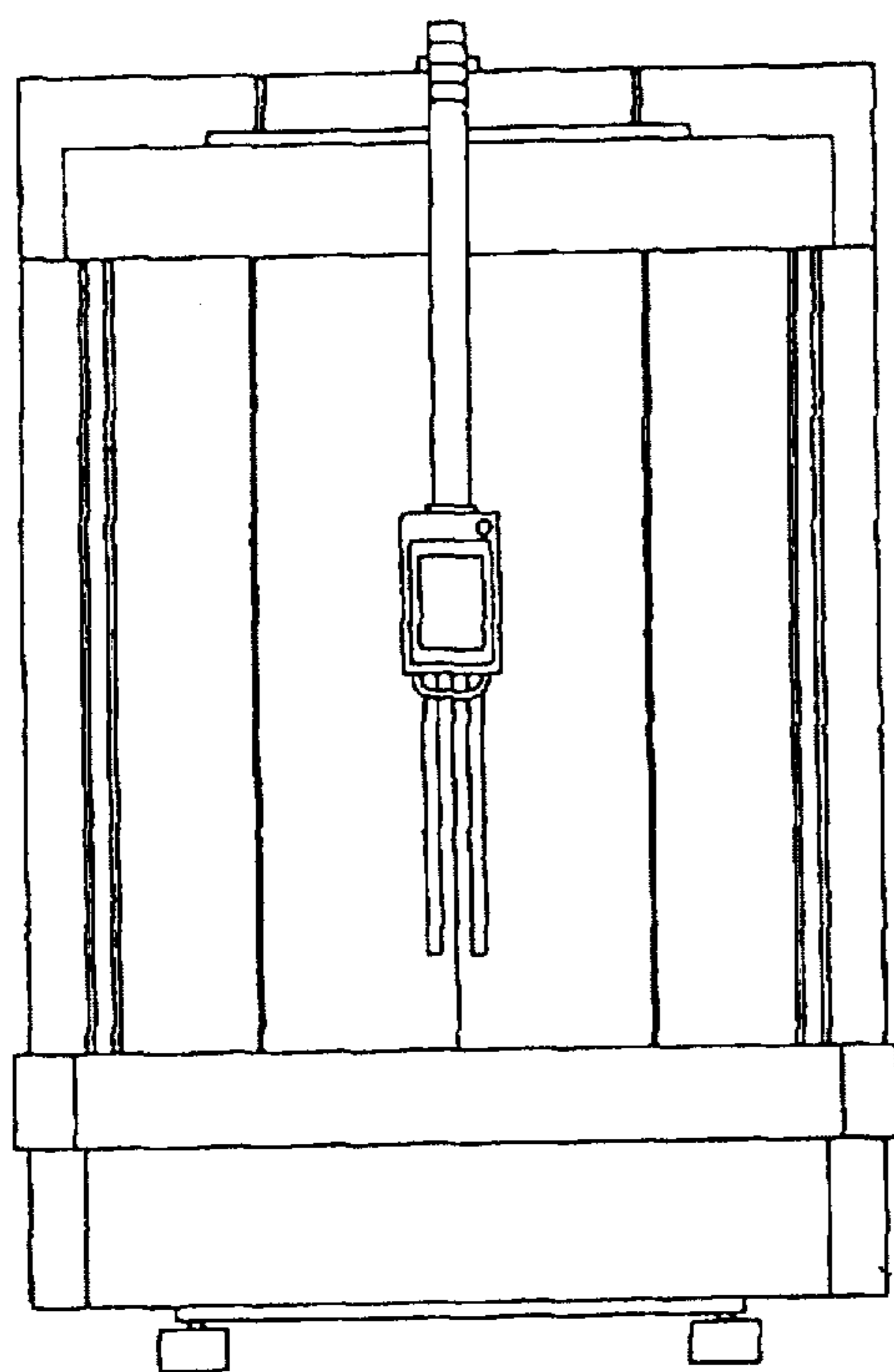

Fig. 11

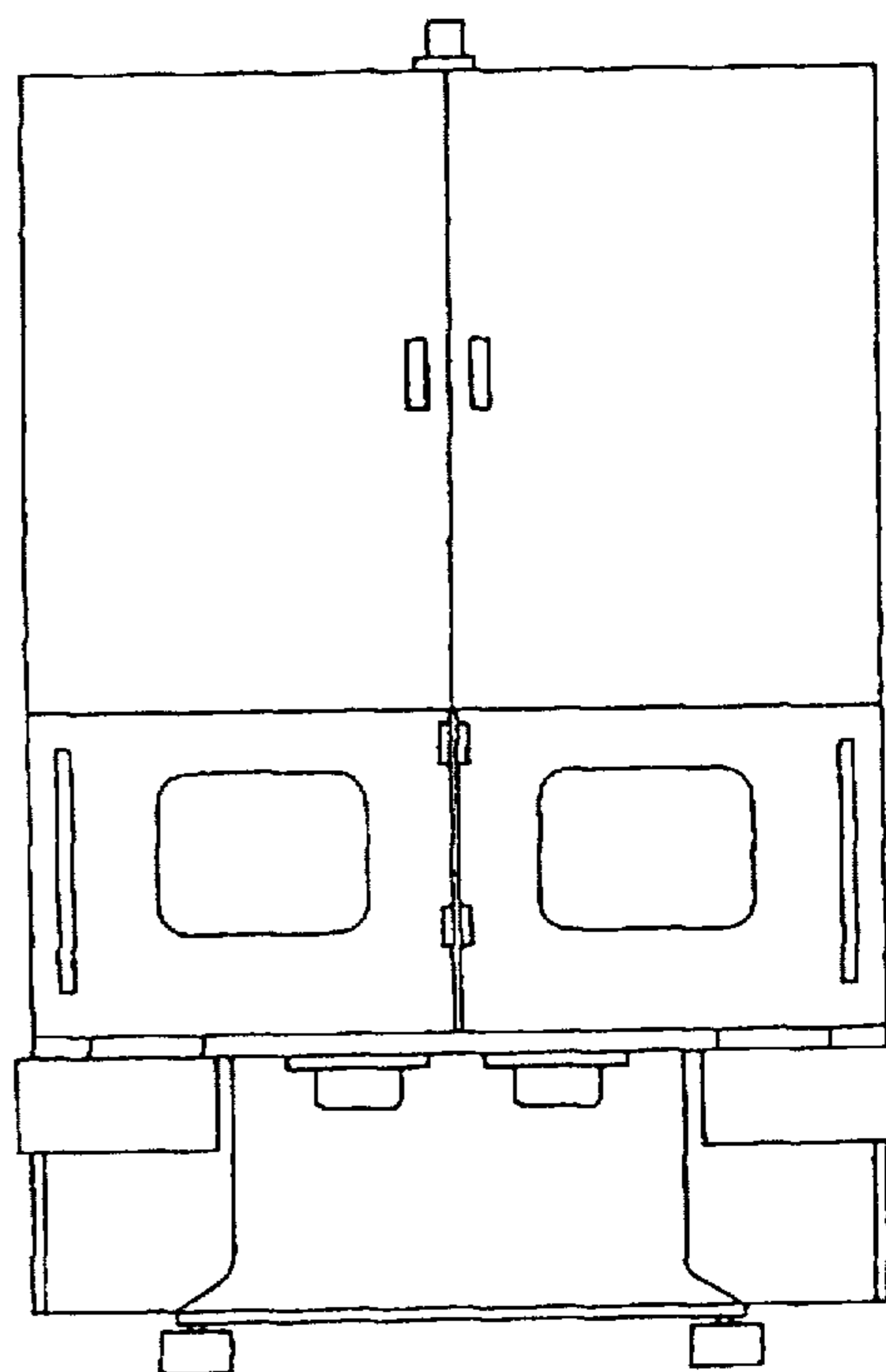

Fig. 12

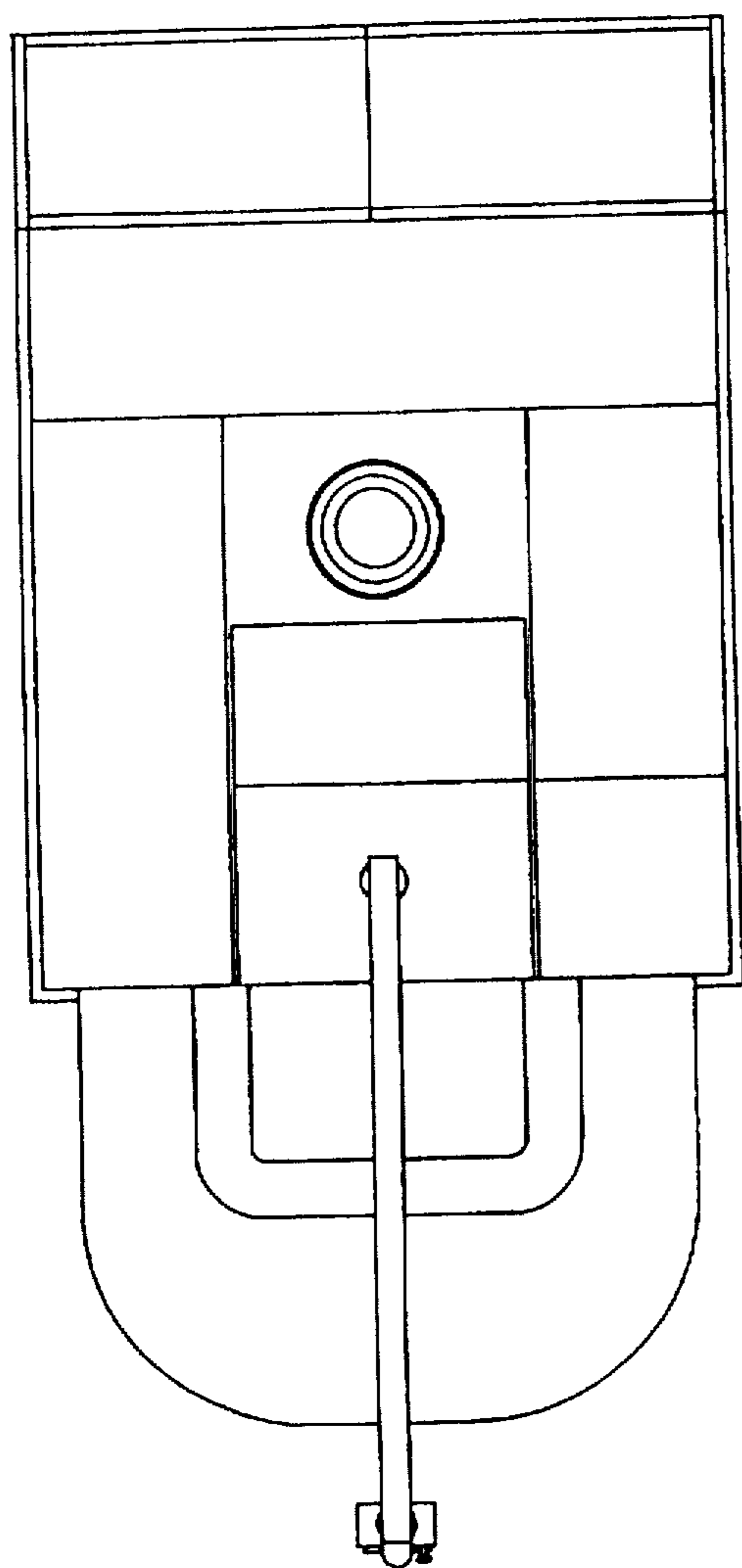

Fig. 13

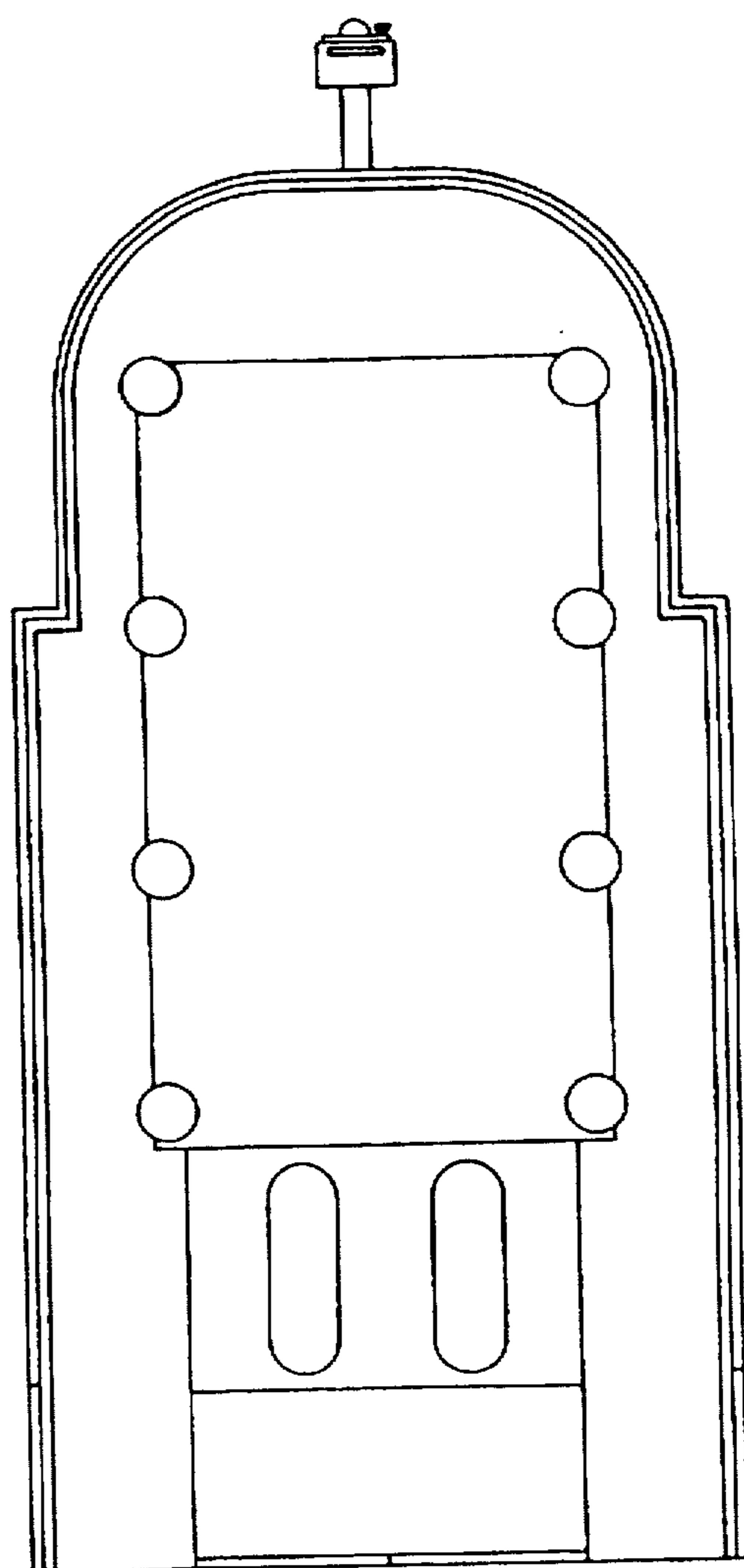

Fig. 14

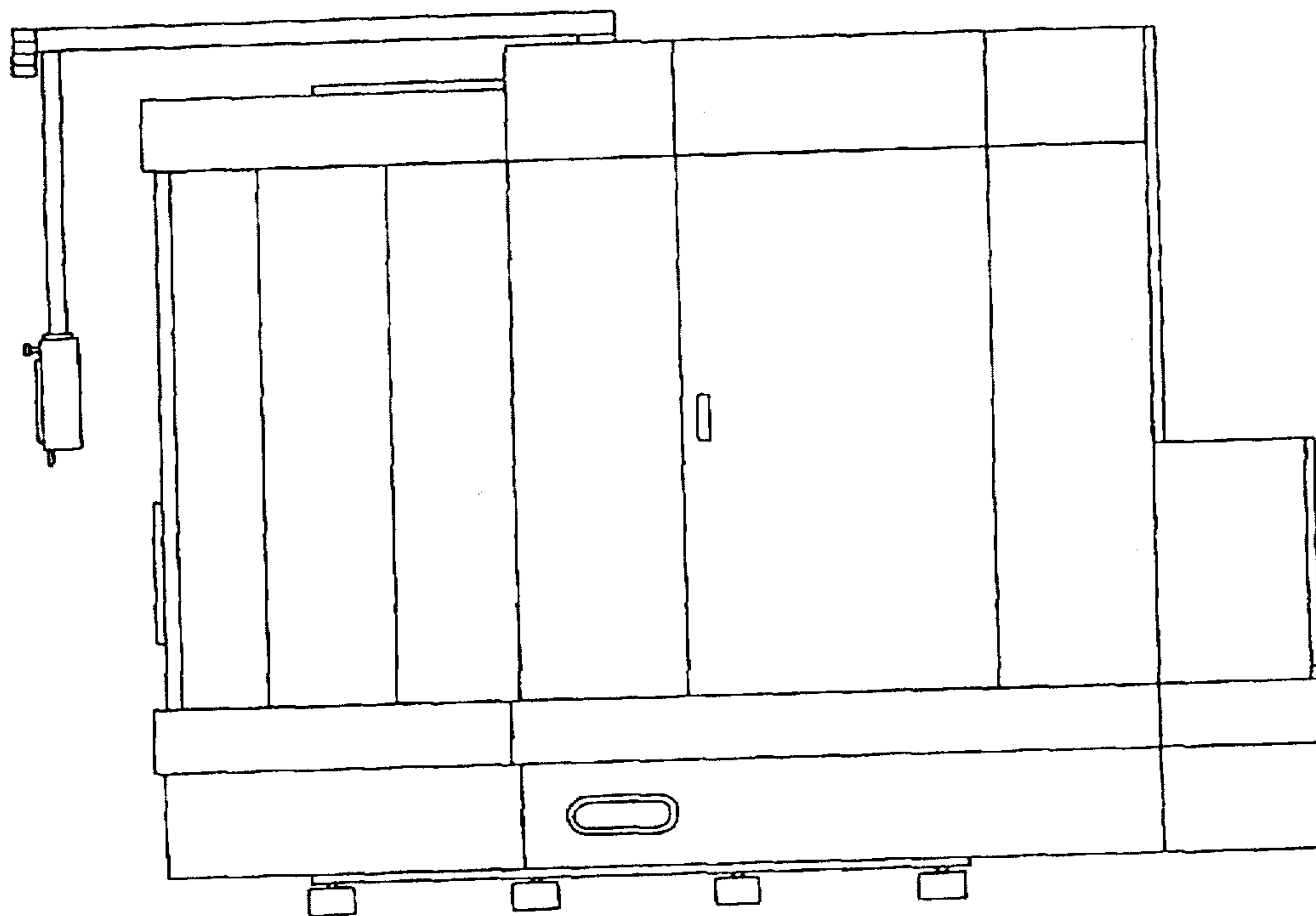

Fig. 15

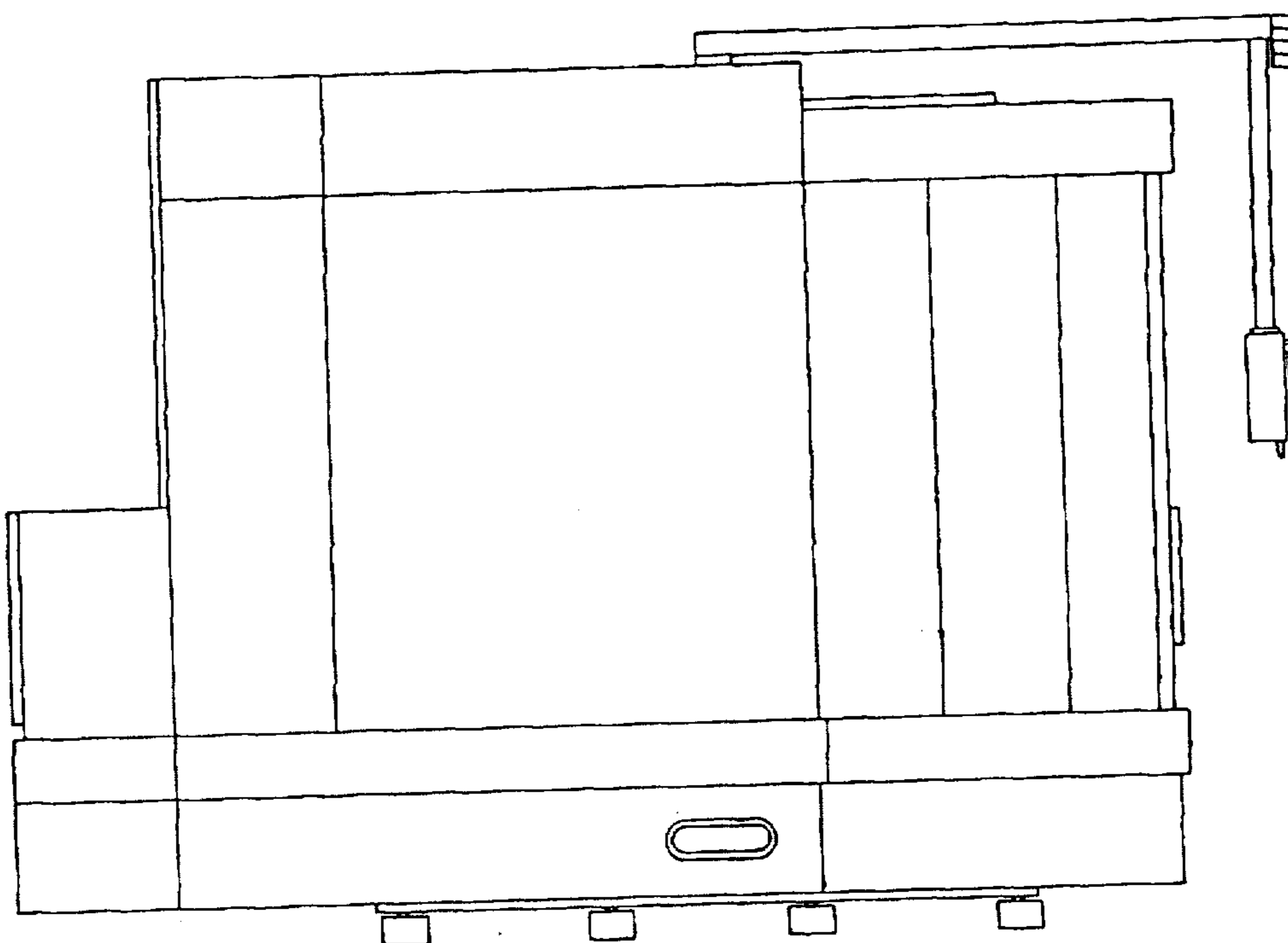

Fig. 16

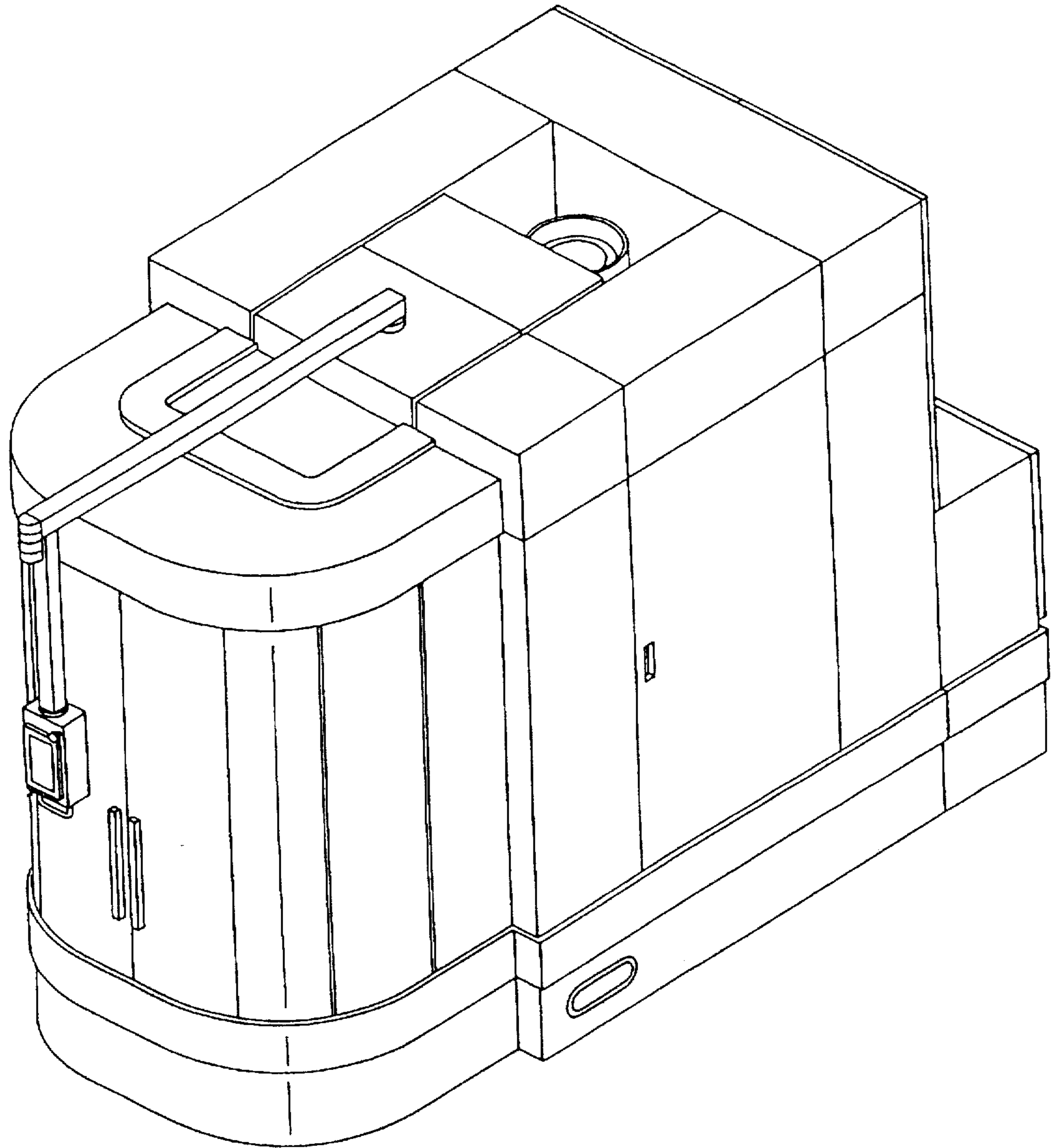

Fig. 17

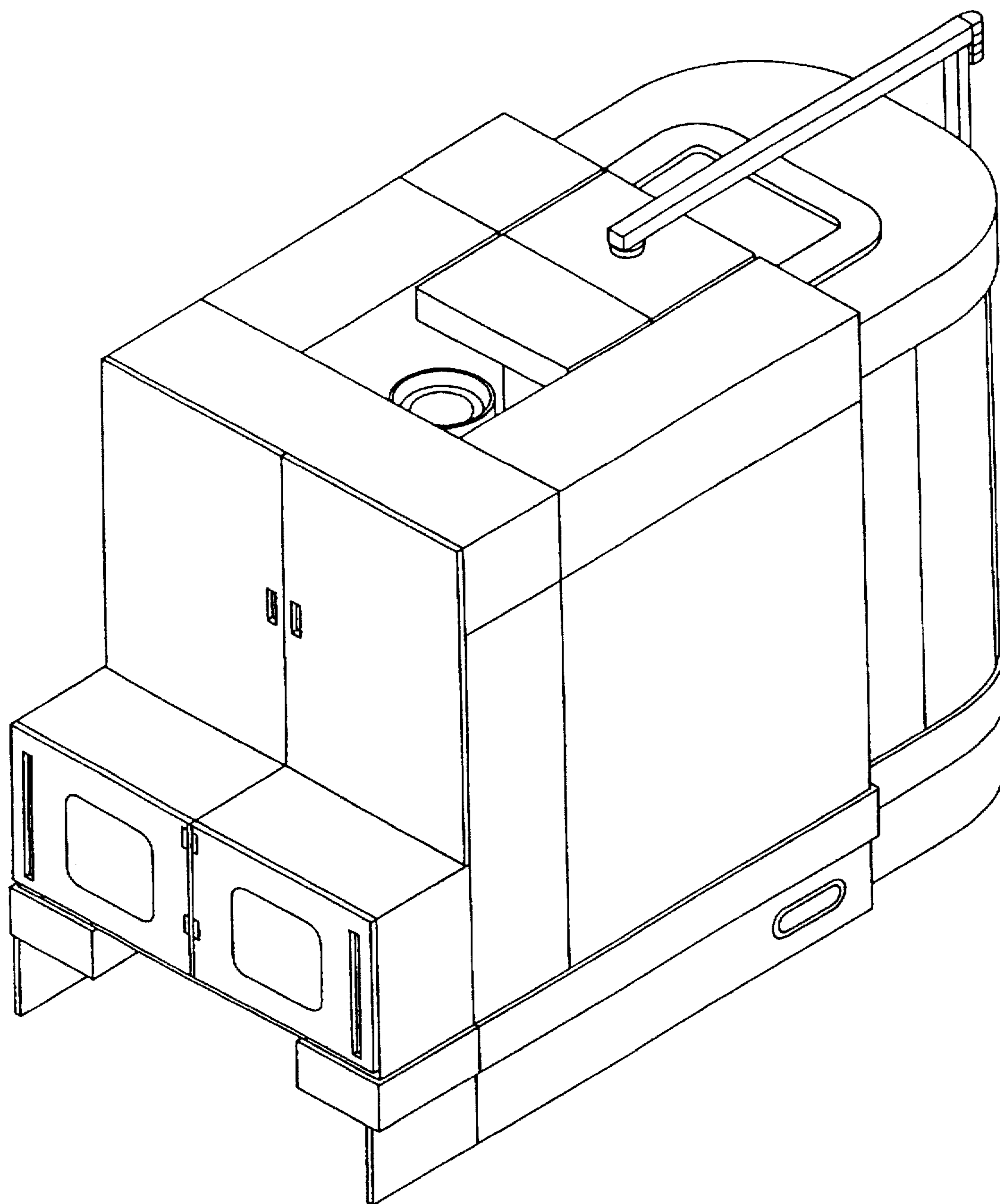

Fig. 18

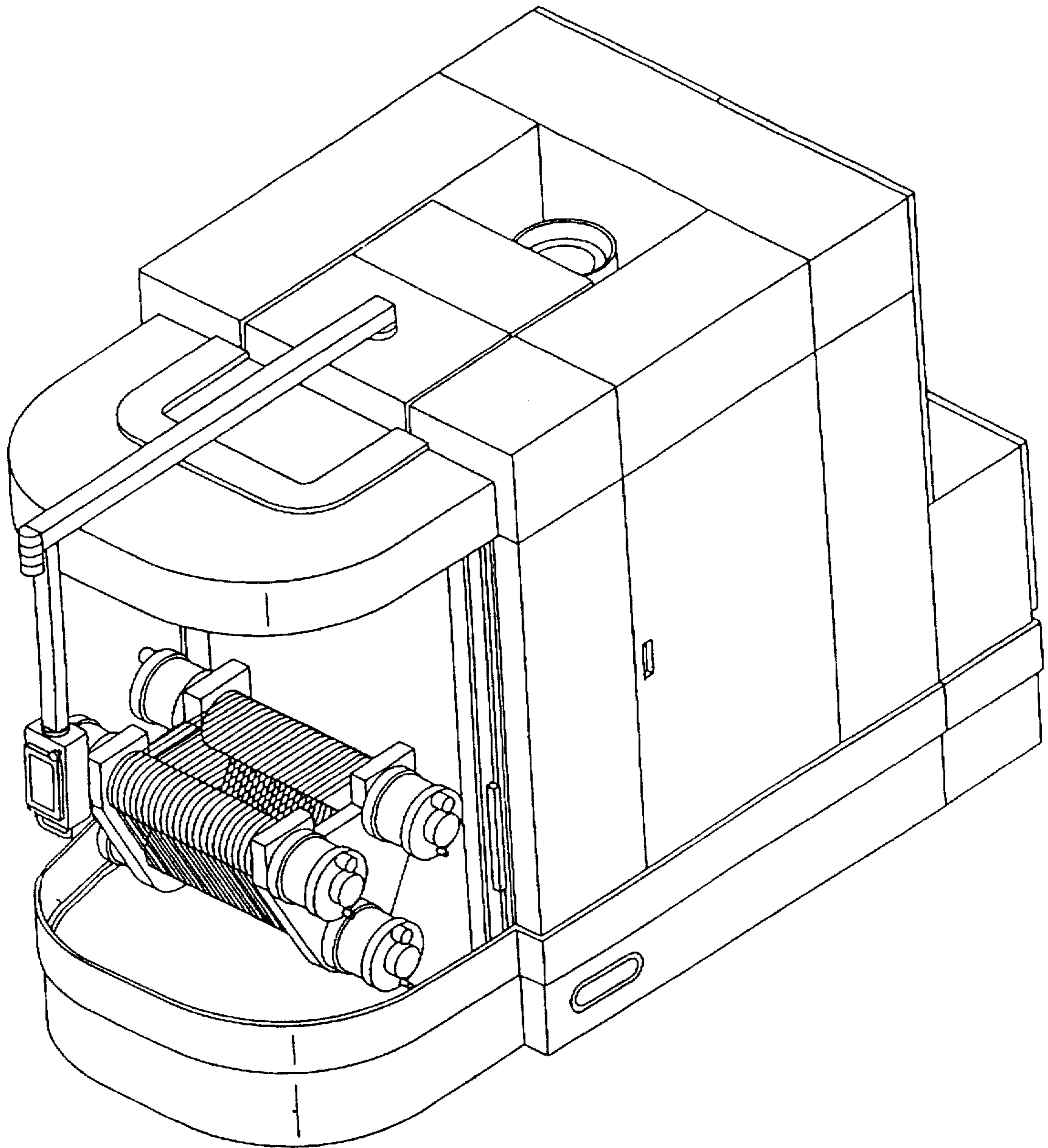

Fig. 19

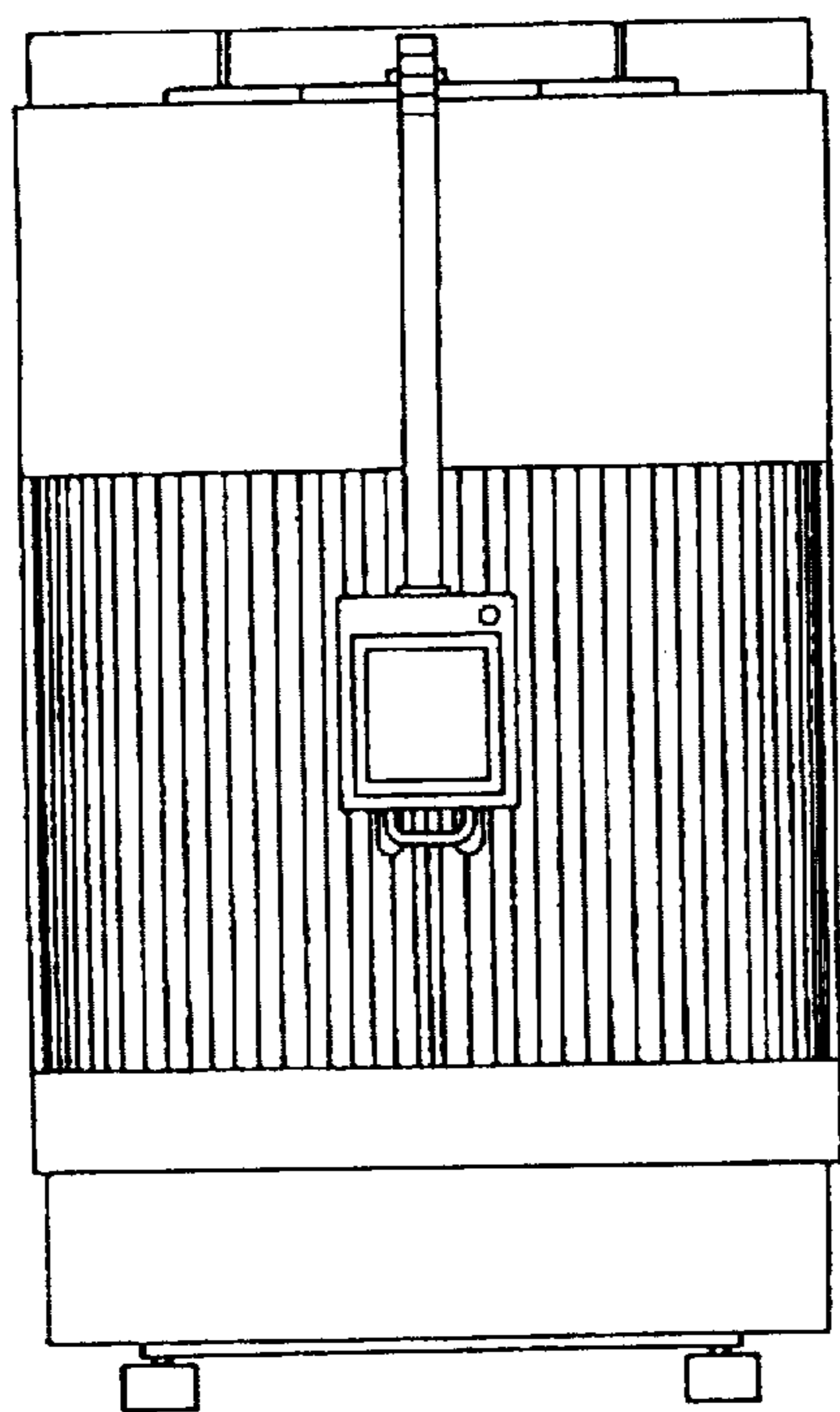

Fig. 20

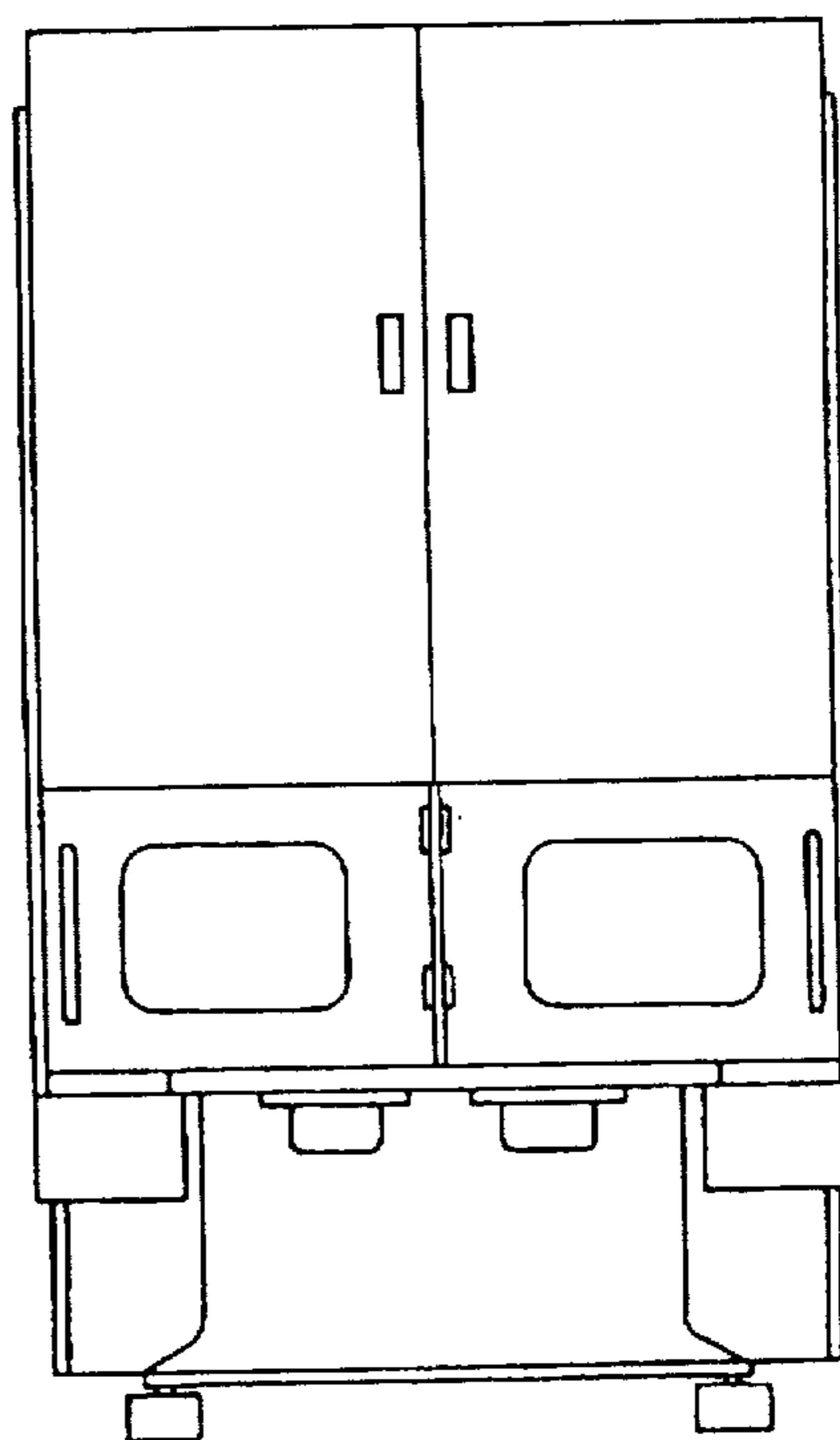

Fig. 21

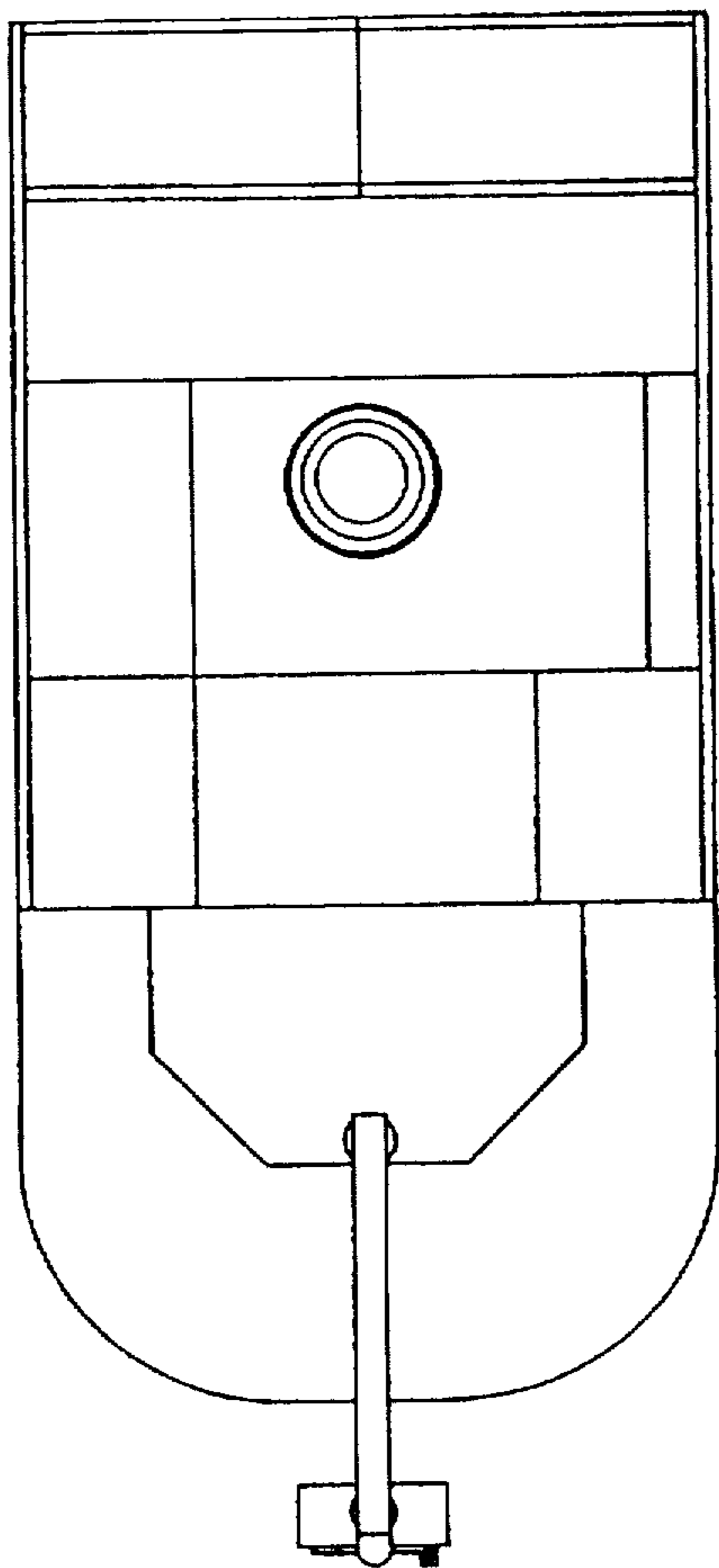

Fig. 22

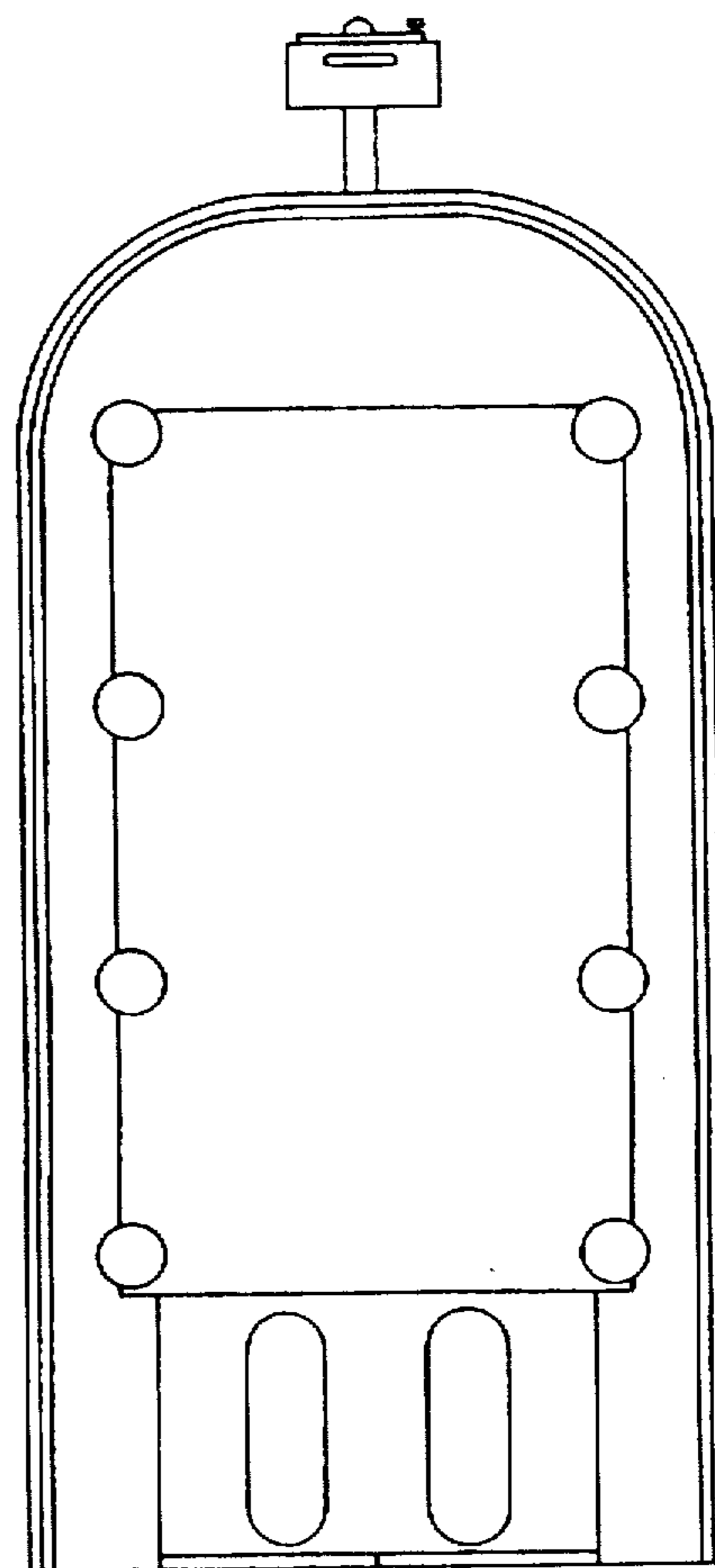

Fig. 23

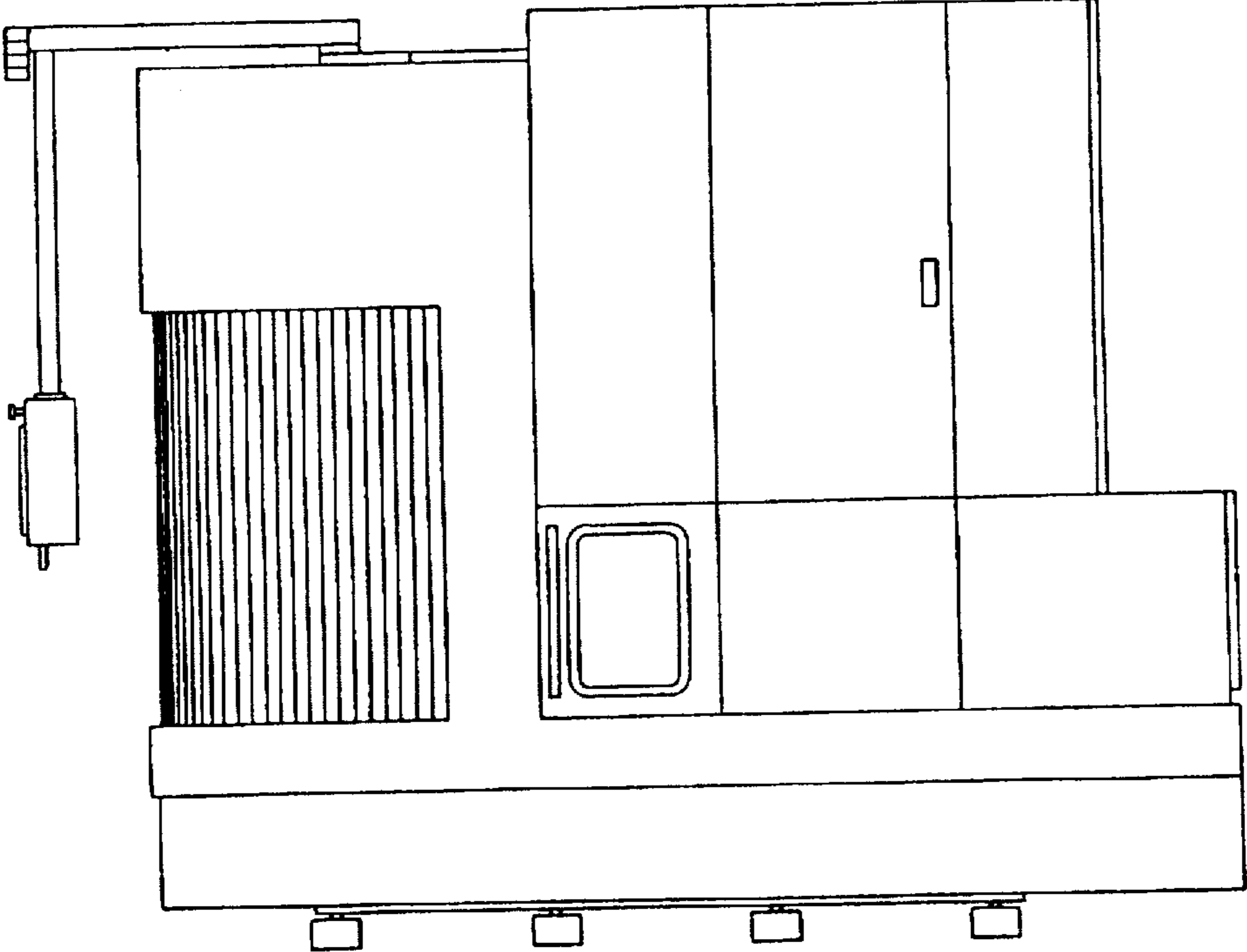

Fig. 24

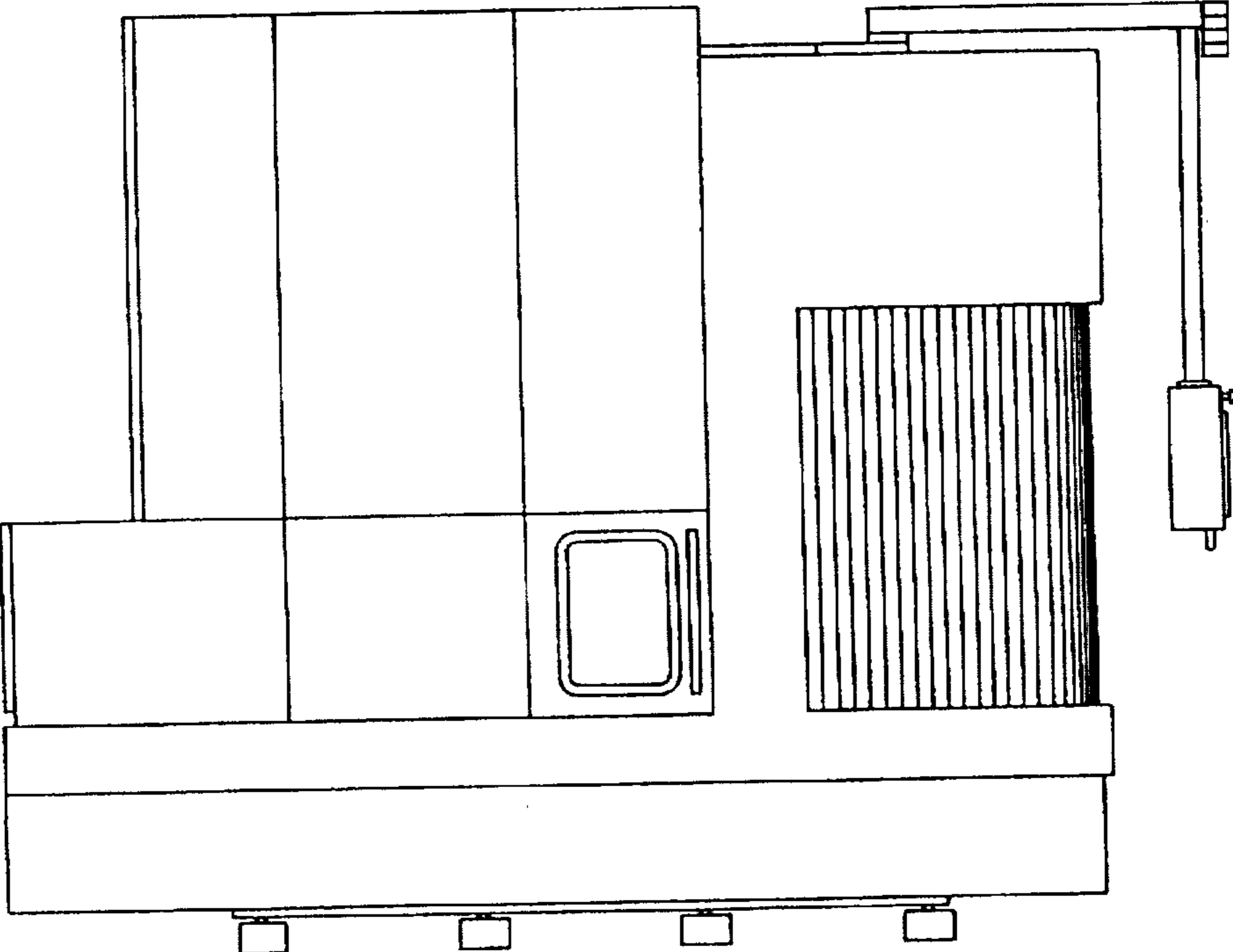

Fig. 25

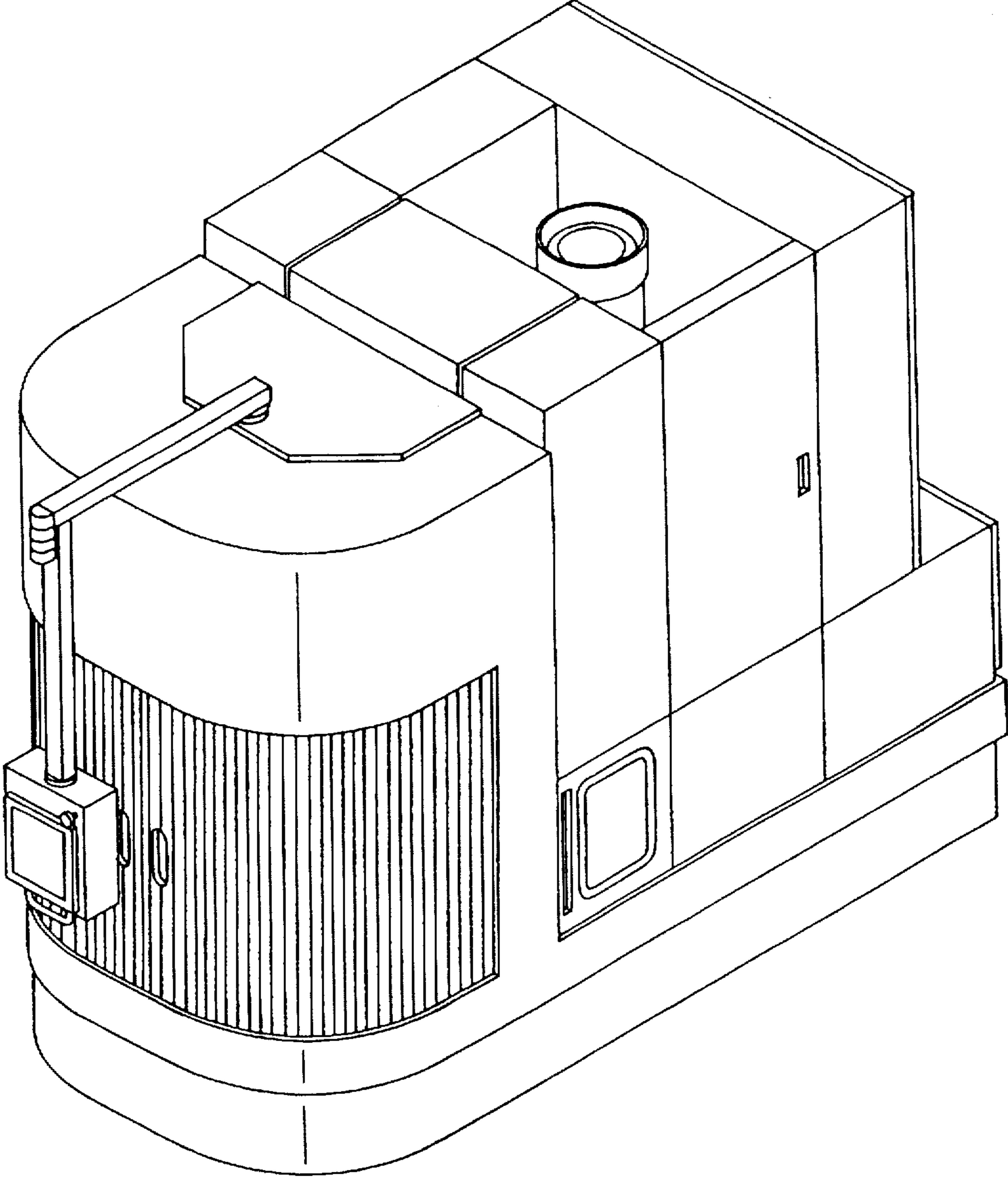

Fig. 26

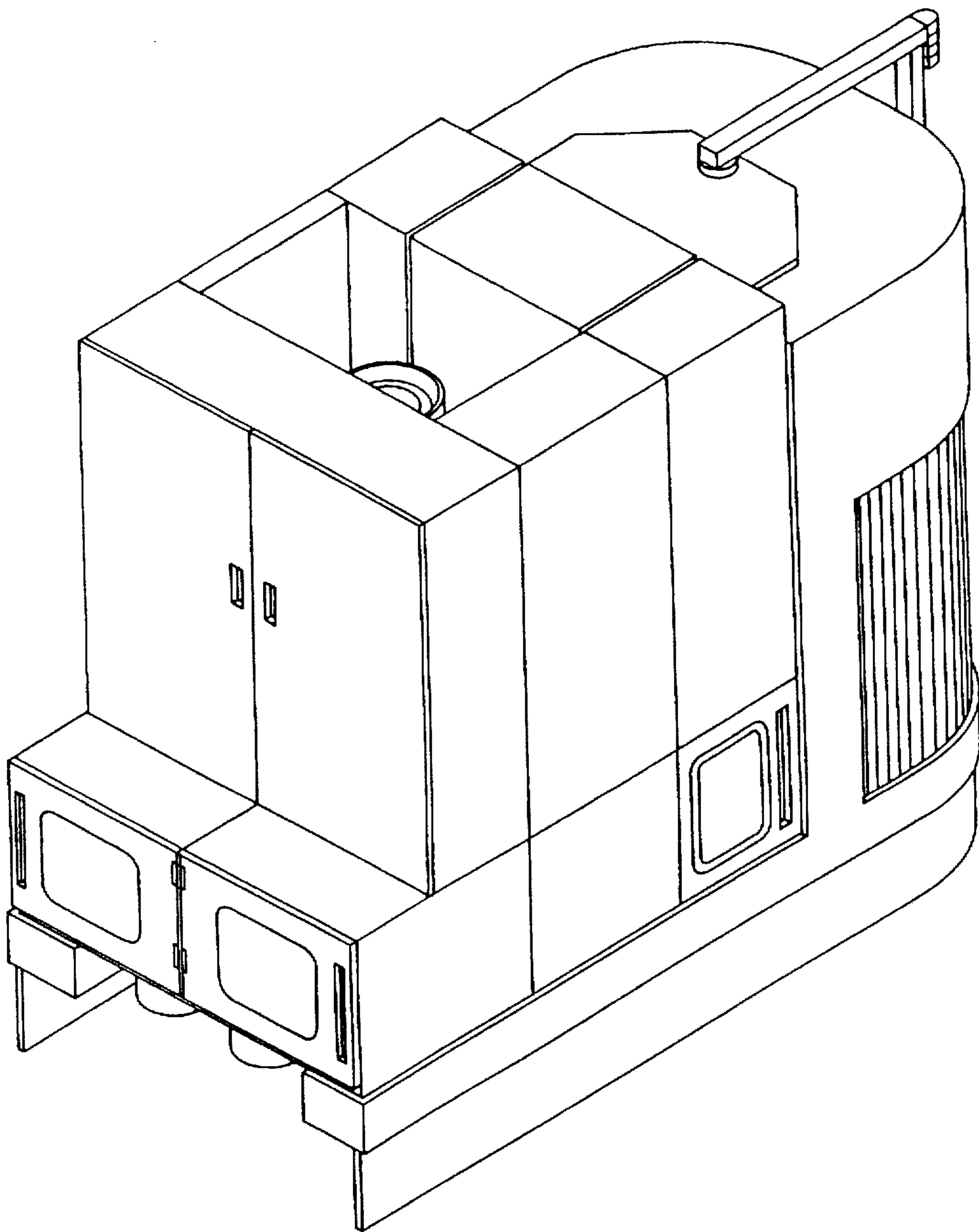

Fig. 27

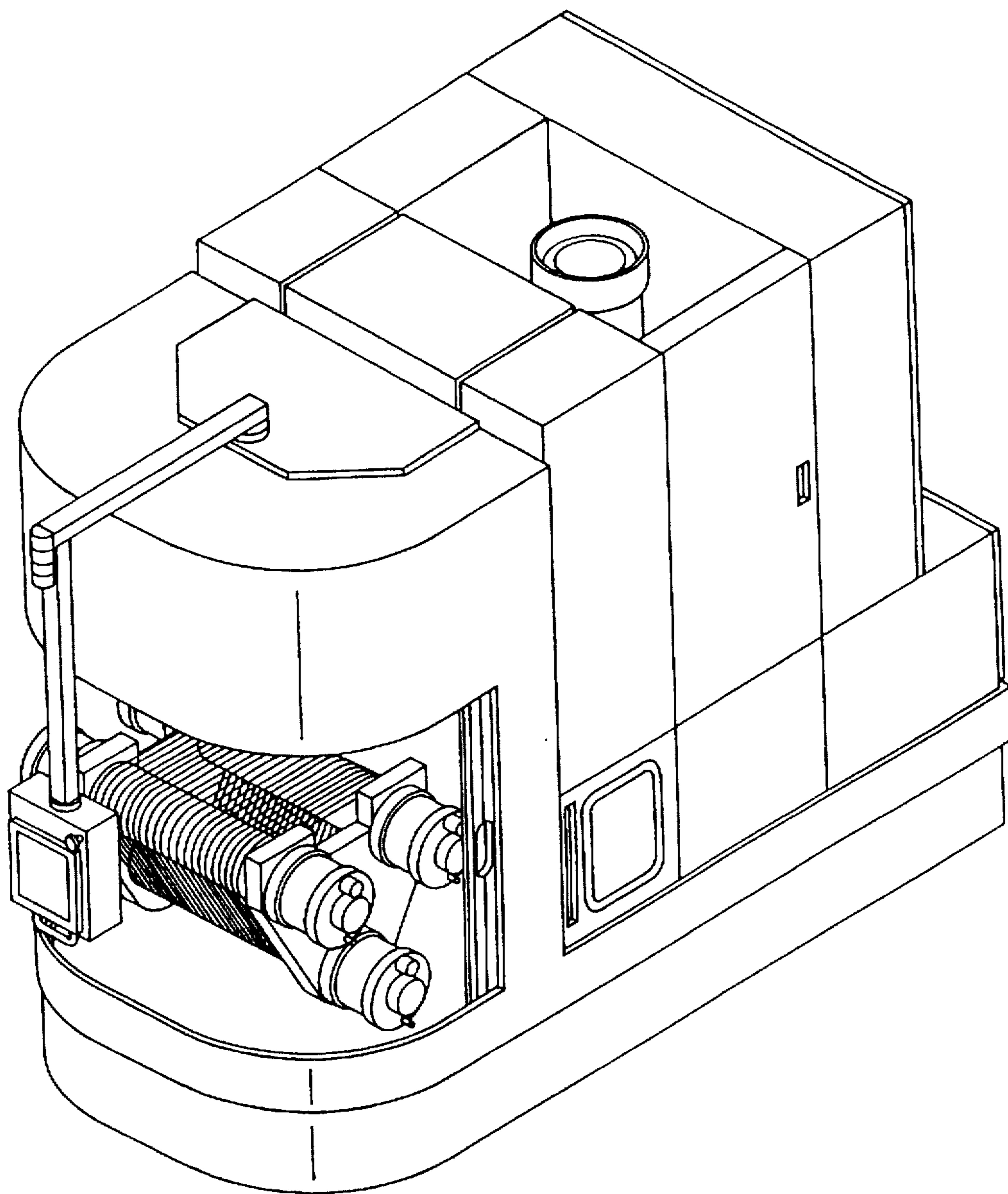

Fig. 28

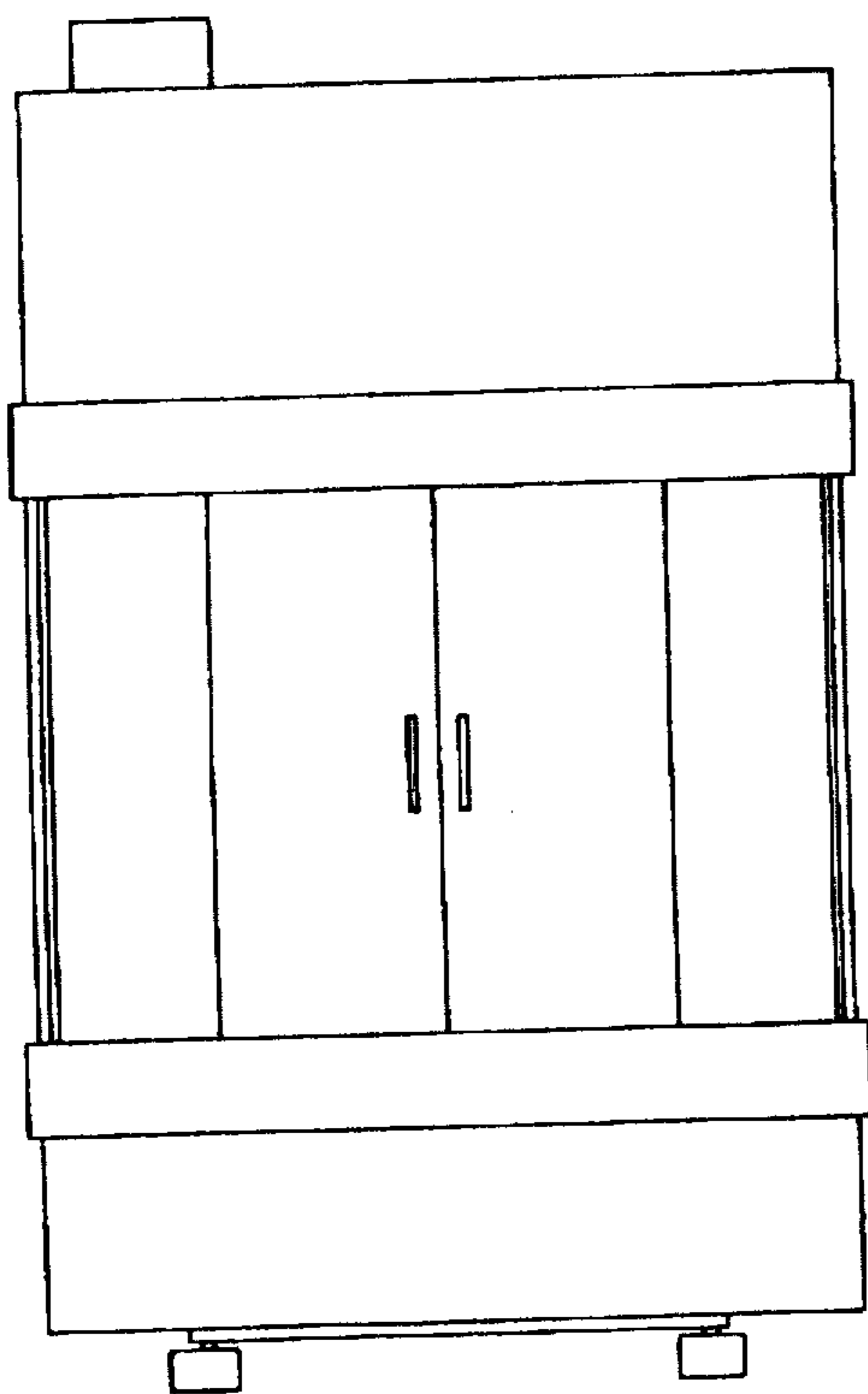

Fig. 29

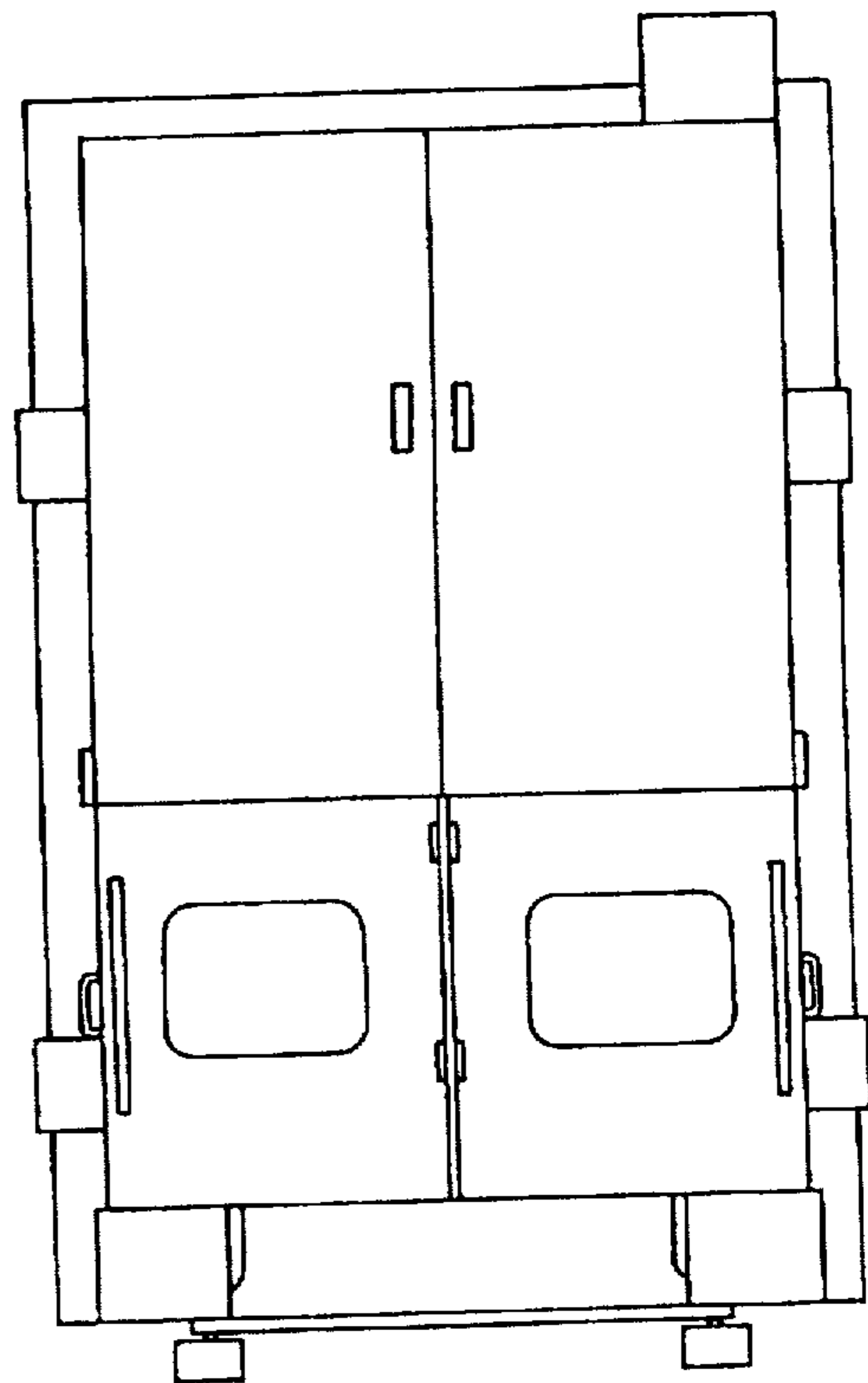

Fig. 30

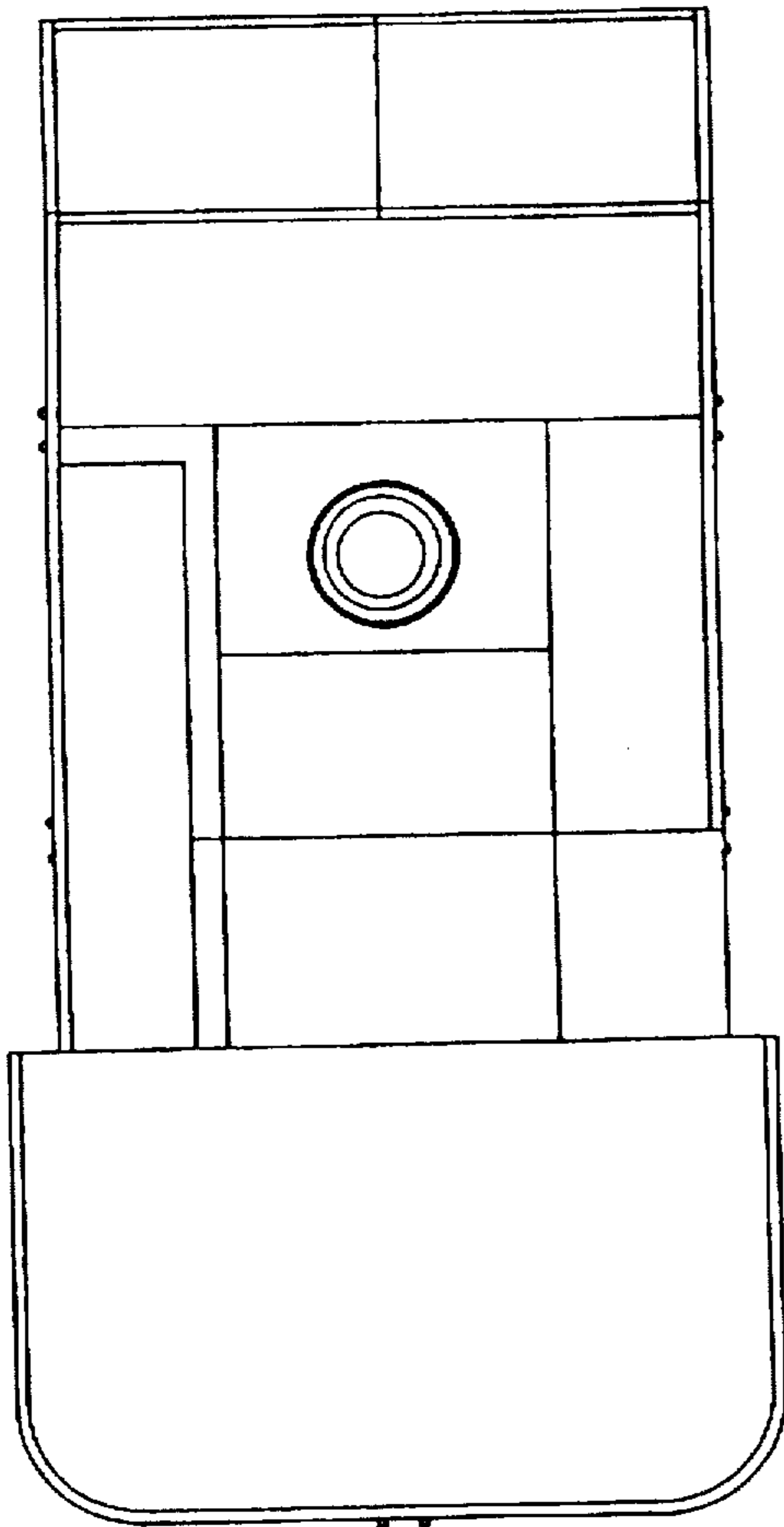

Fig. 31

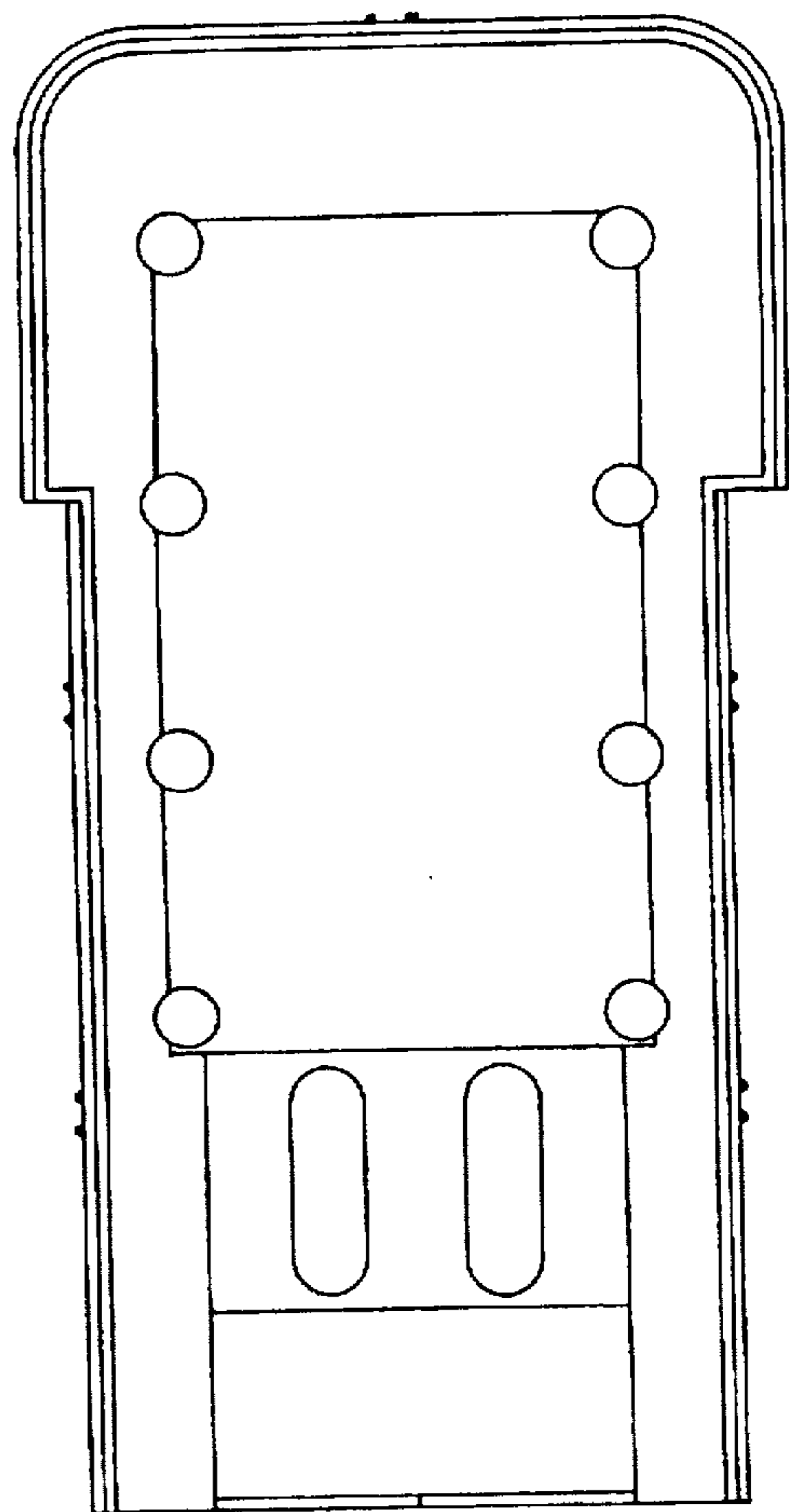

Fig. 32

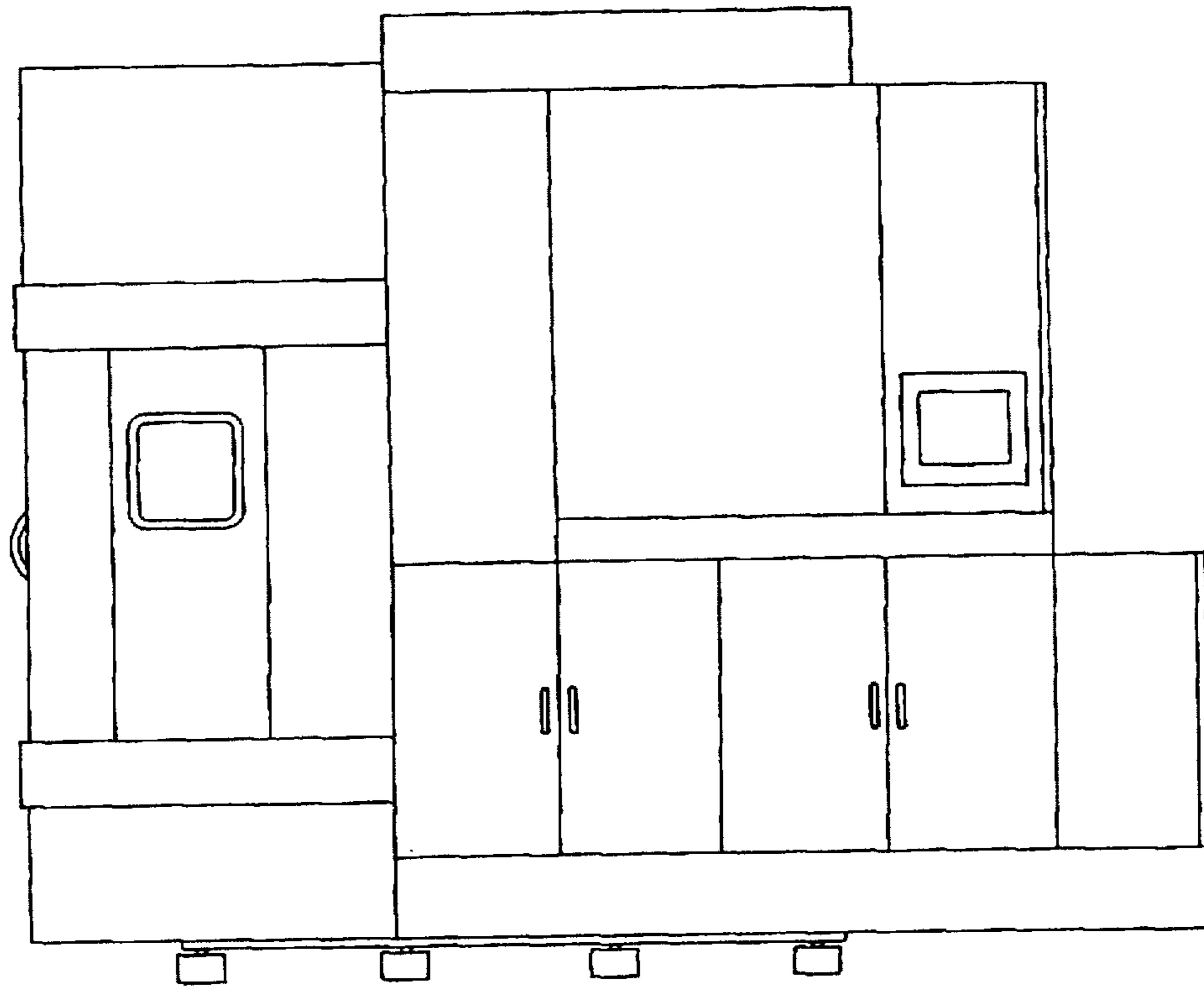

Fig. 33

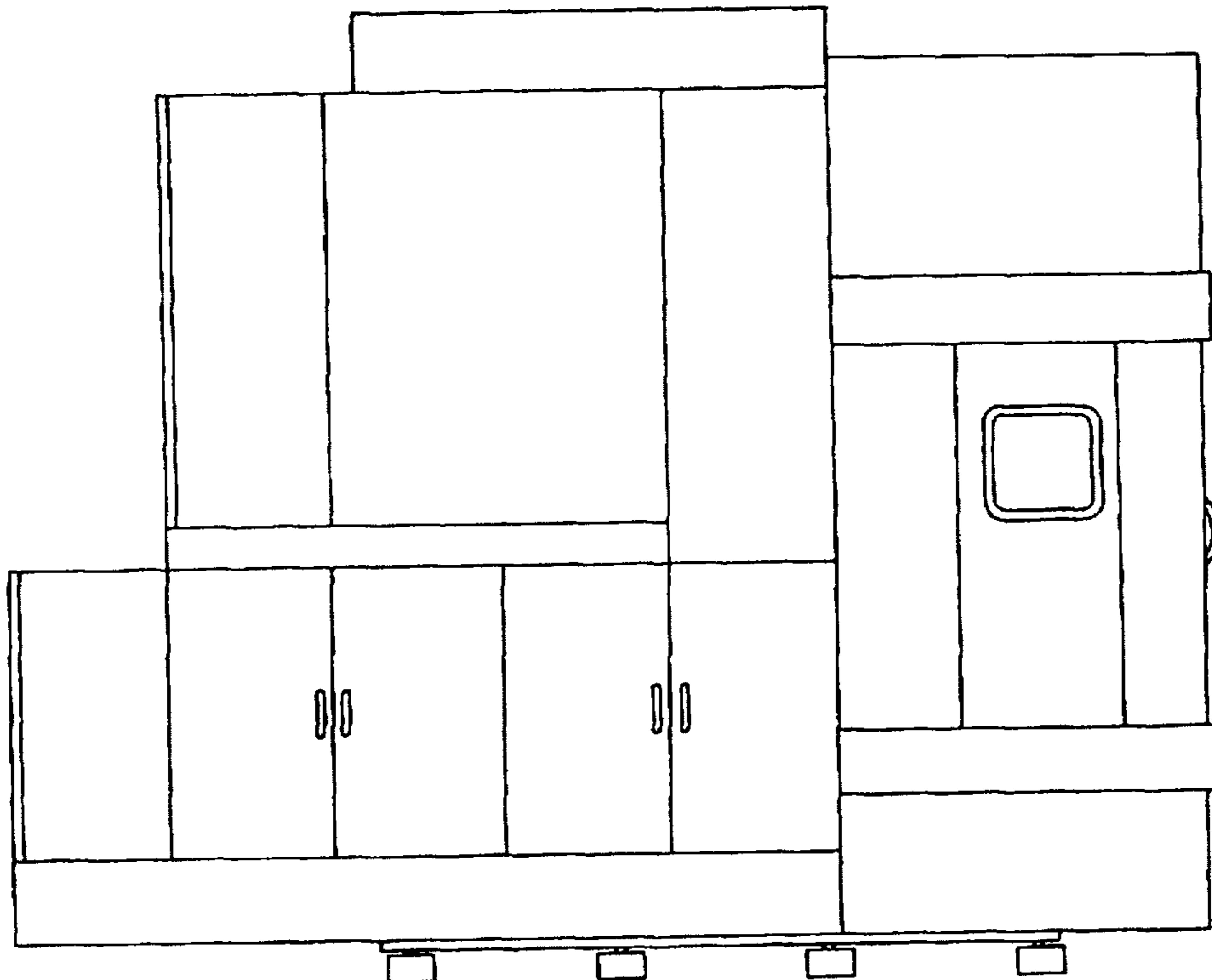

Fig. 34

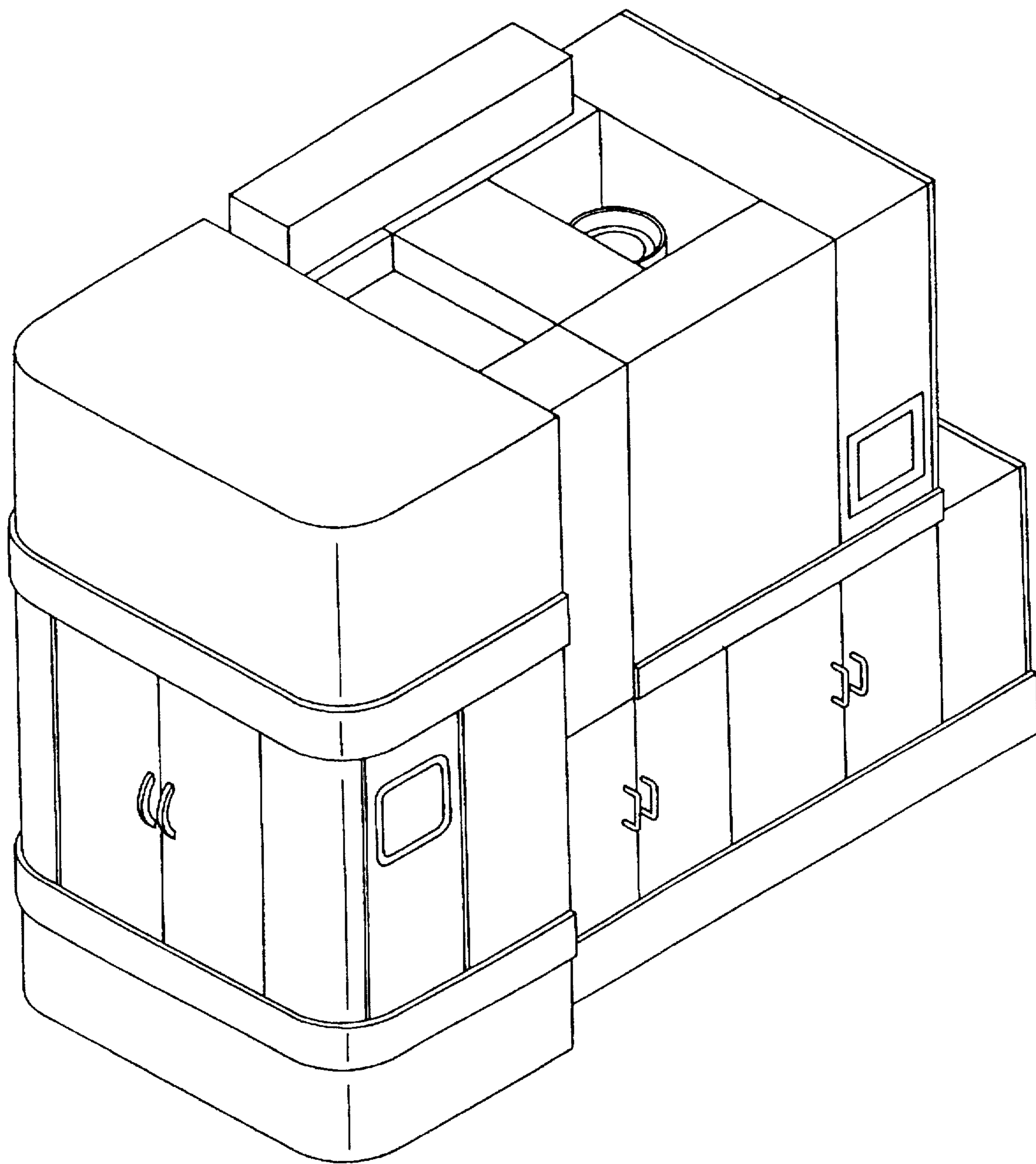

Fig. 35

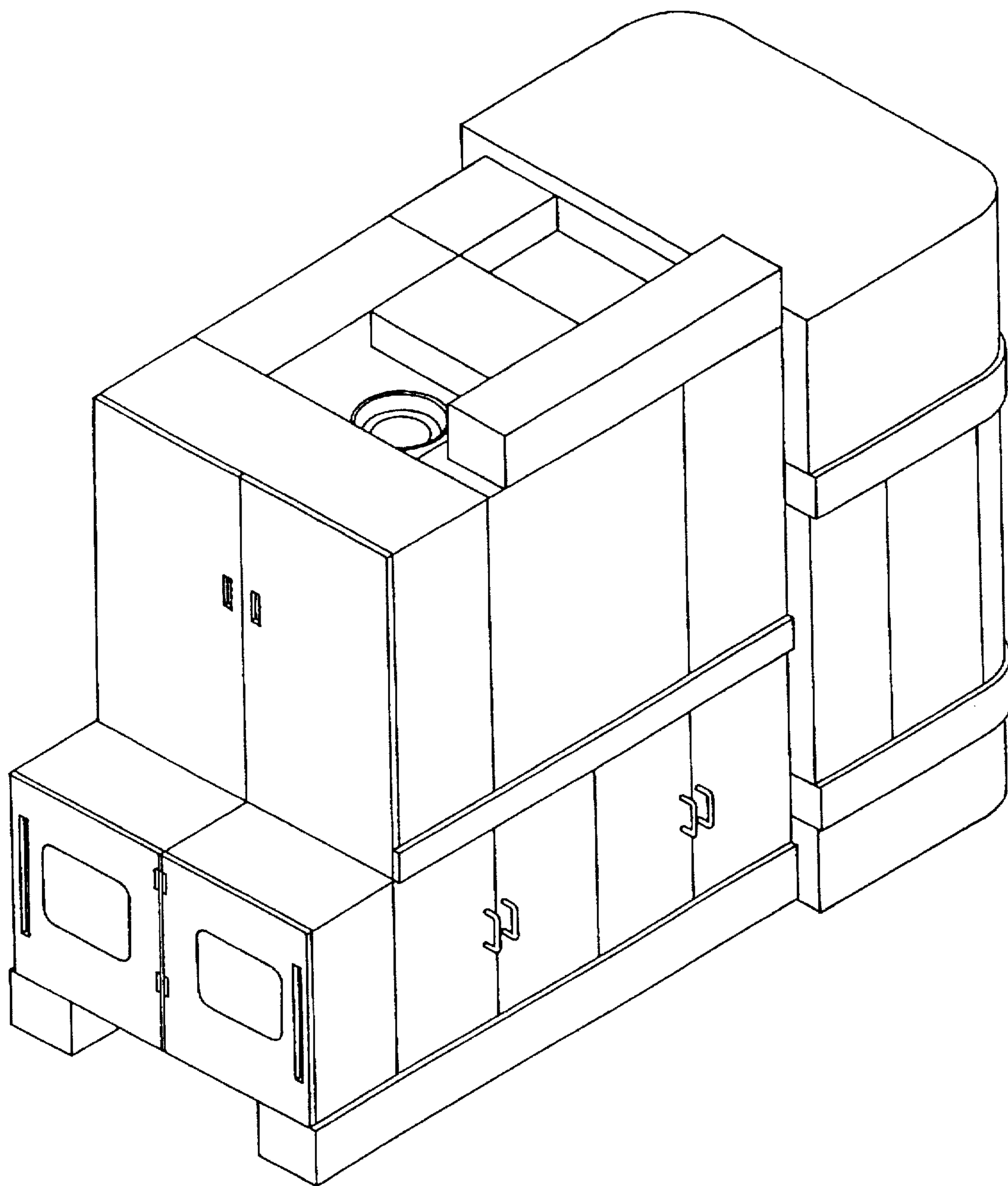

Fig. 36

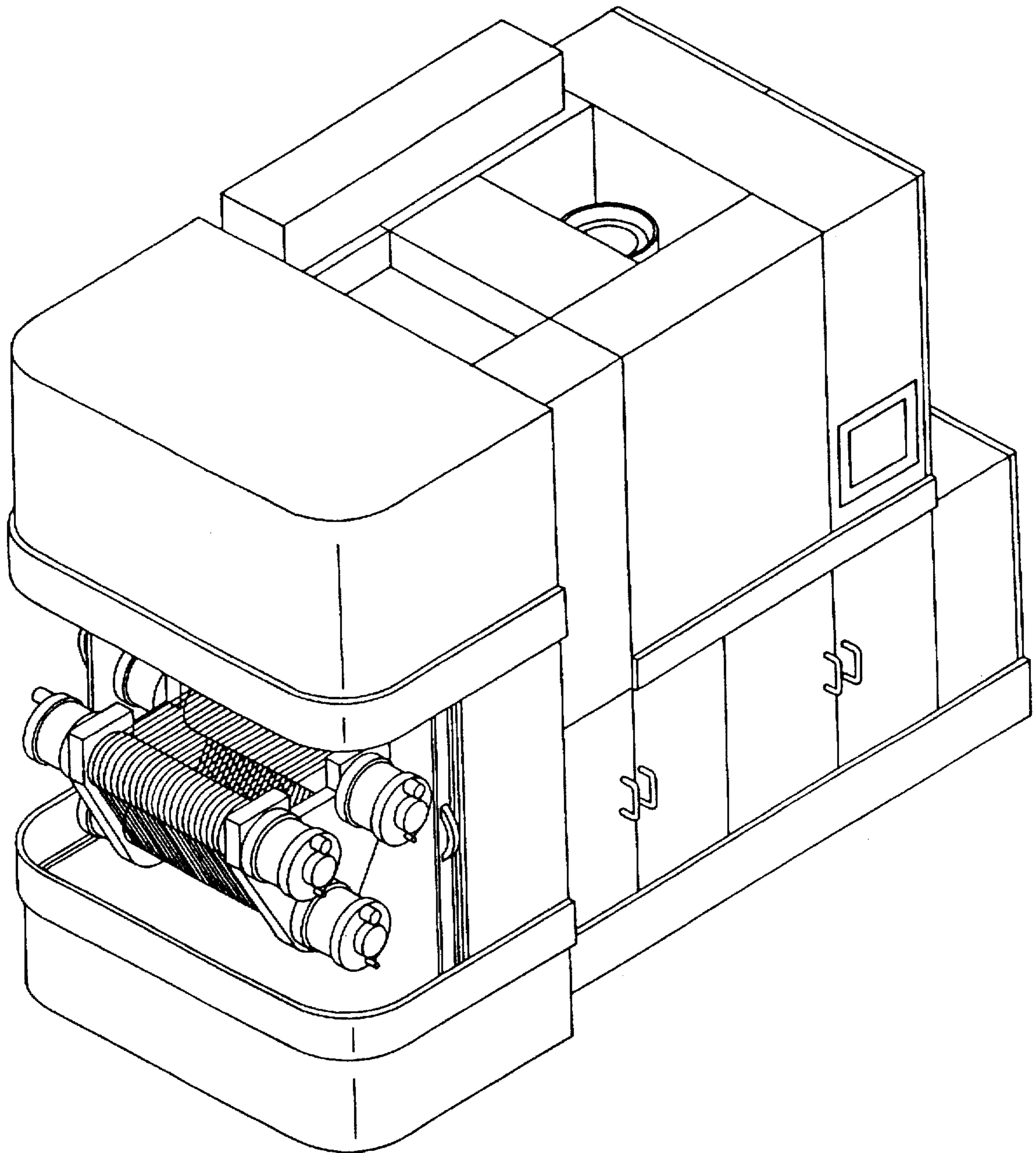

Fig. 37

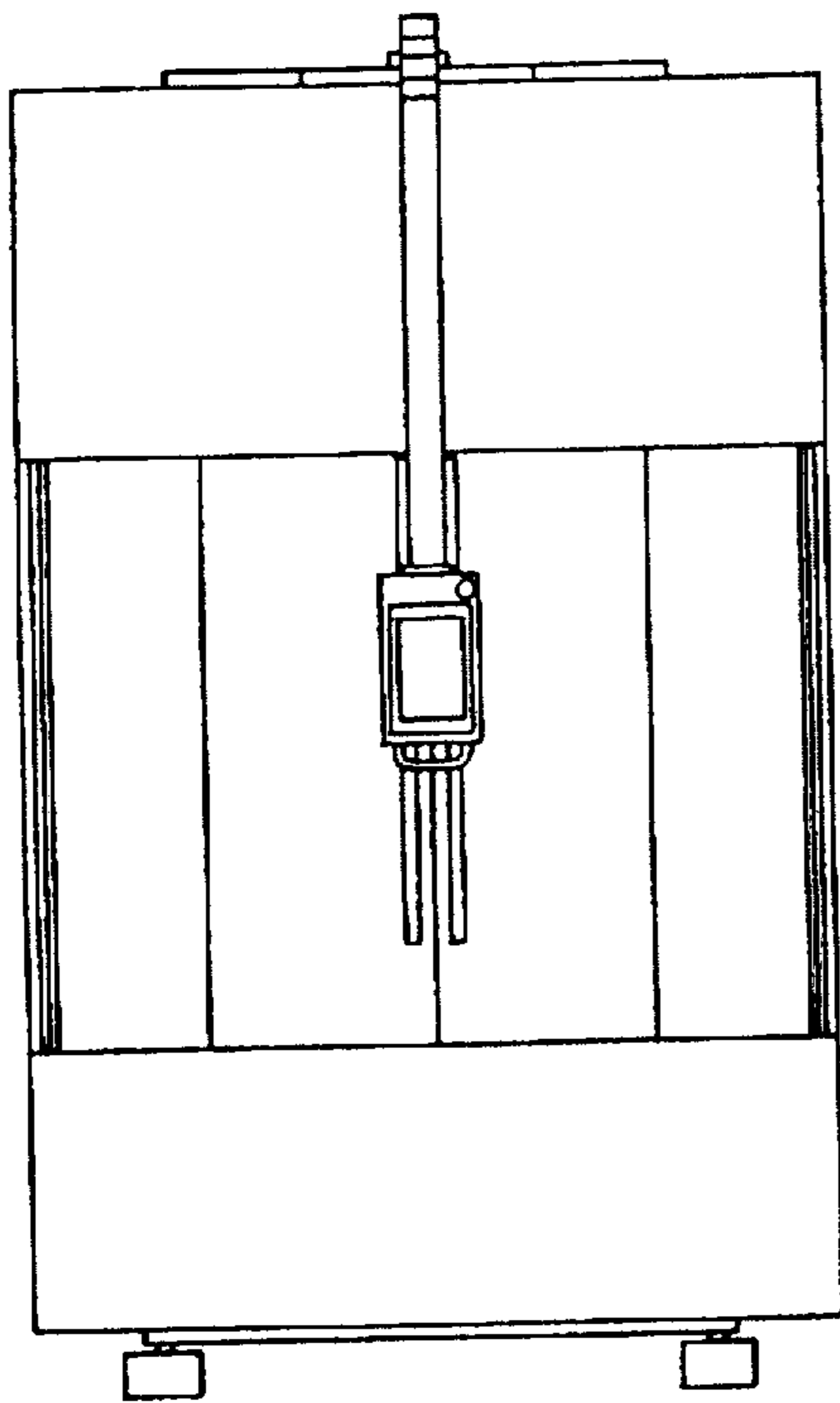

Fig. 38

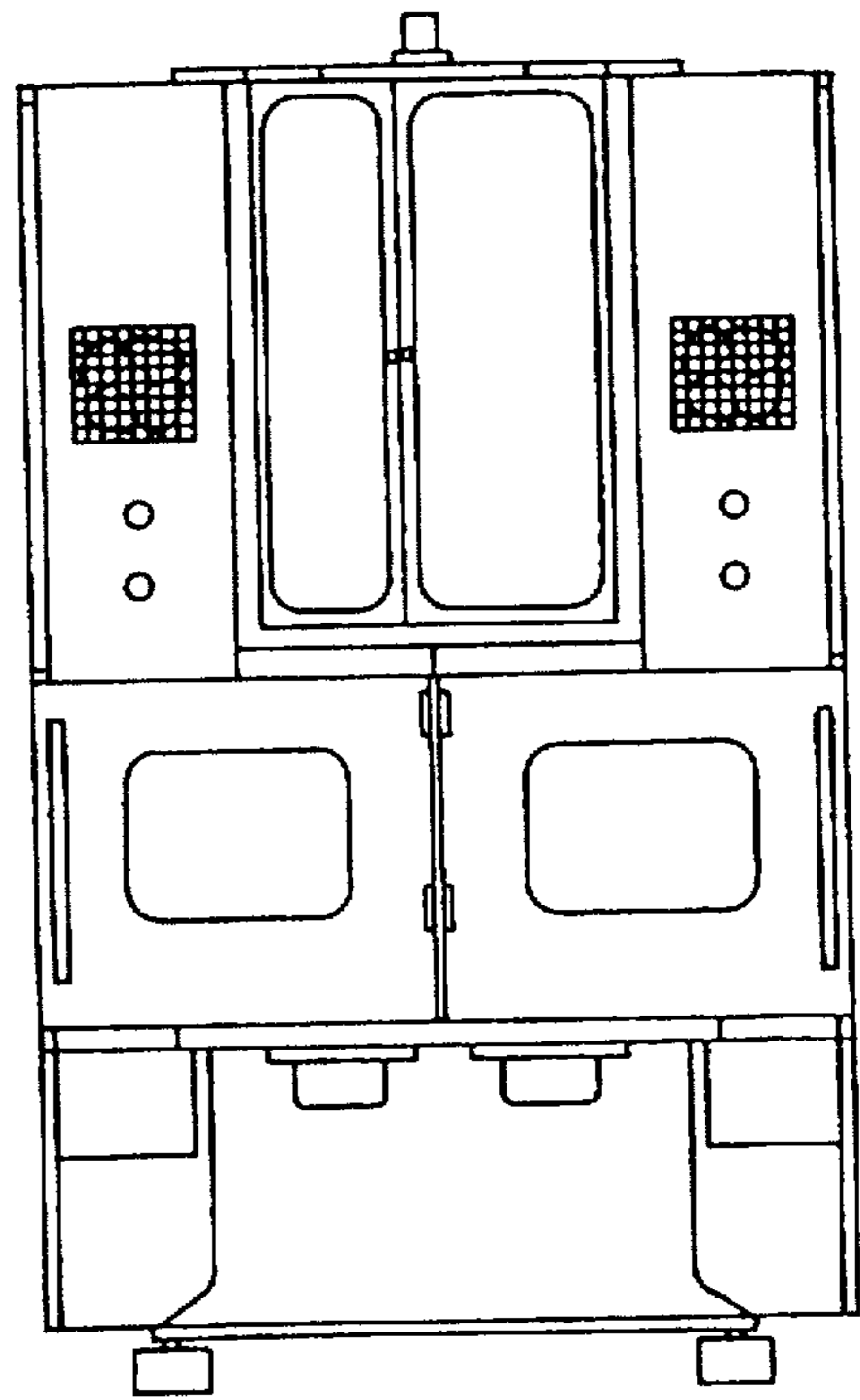

Fig. 39

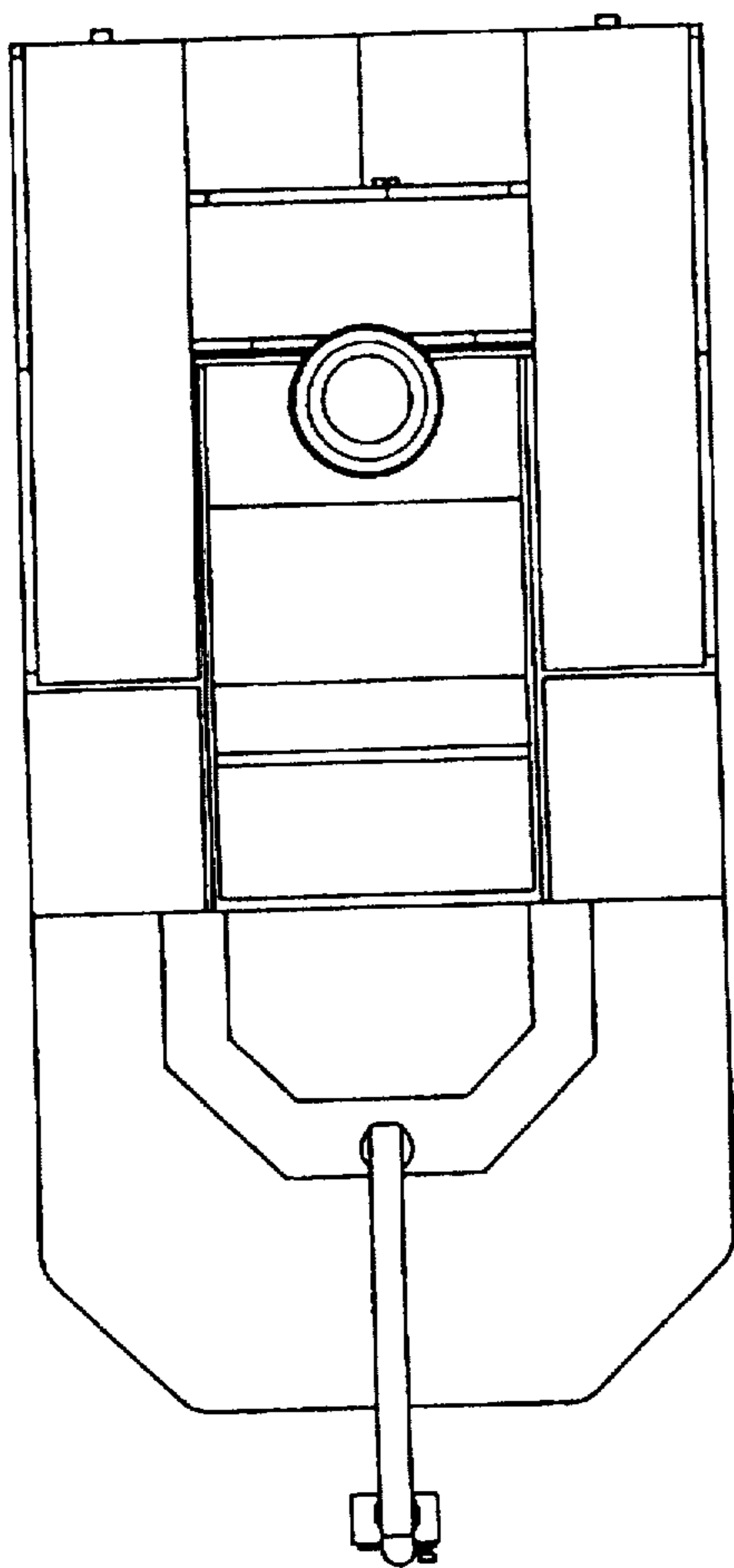

Fig. 40

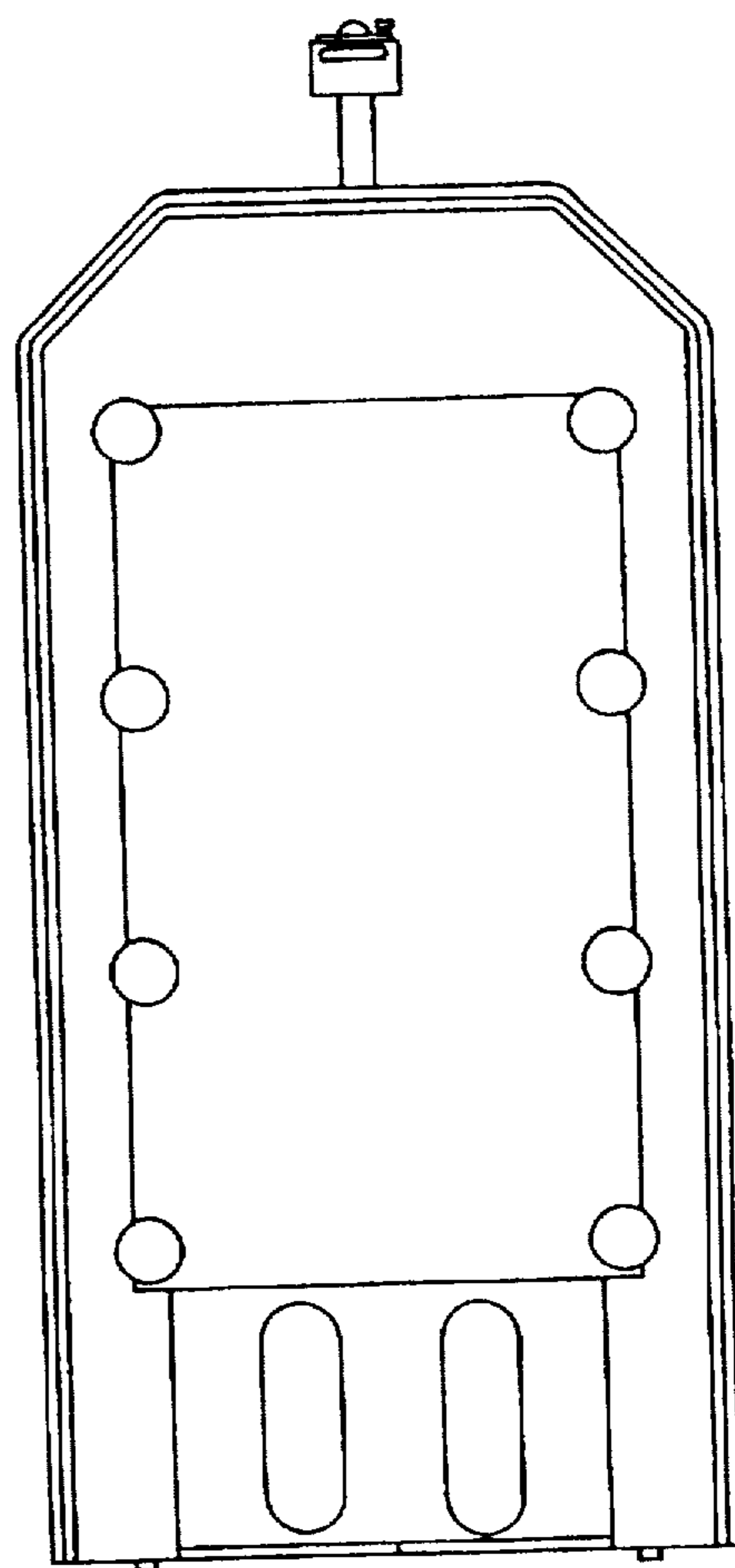

Fig. 41

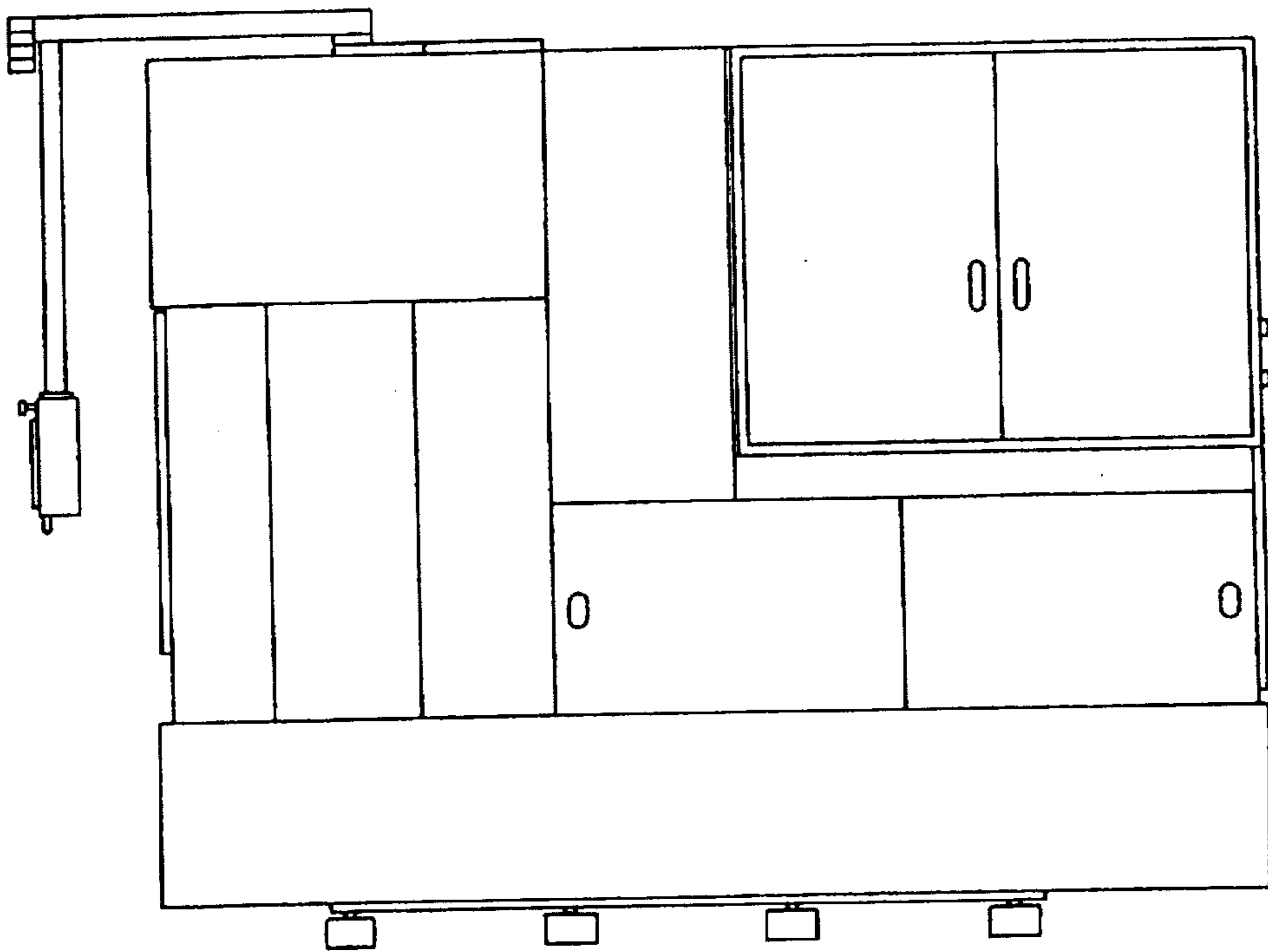

Fig. 42

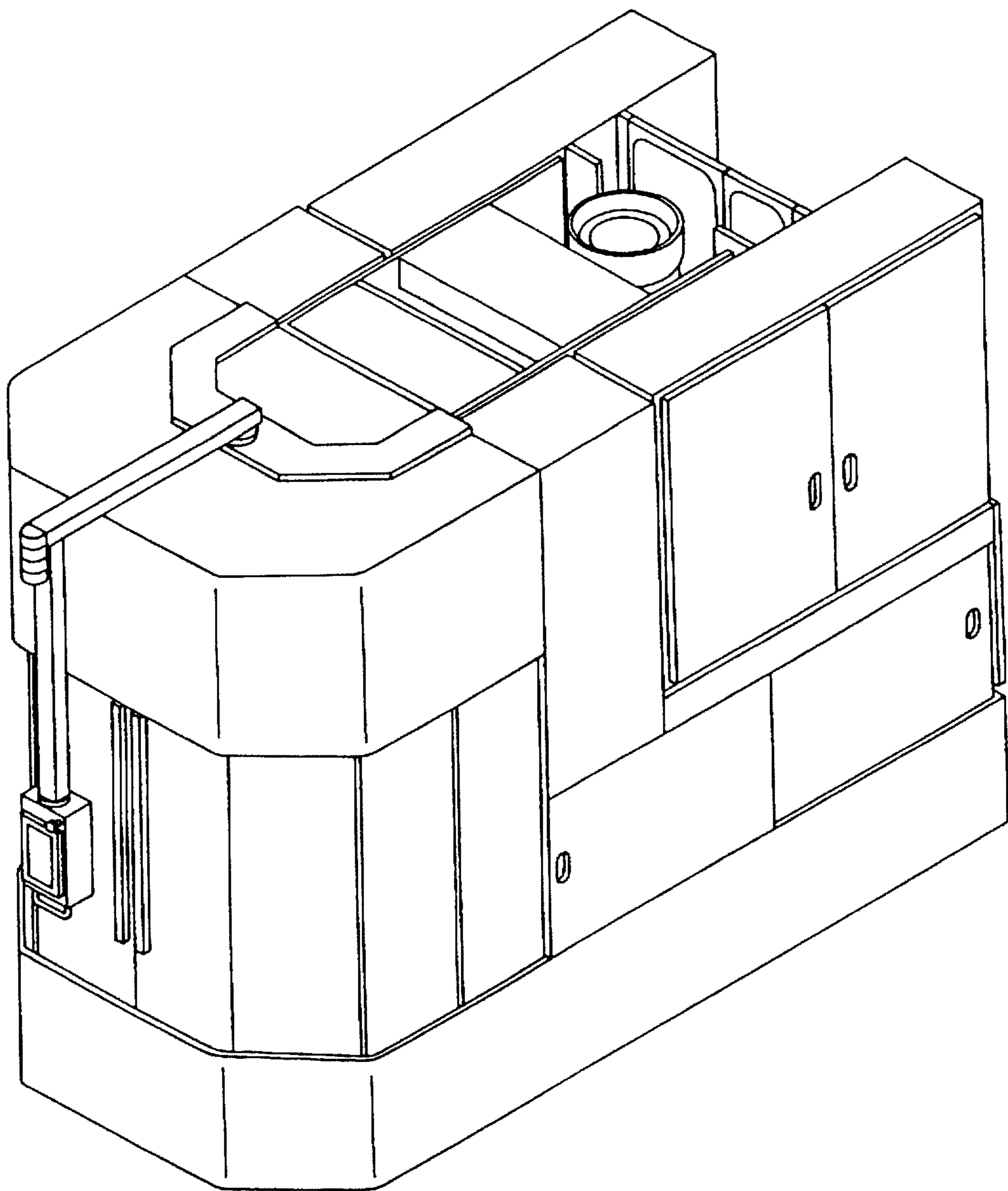

Fig. 43

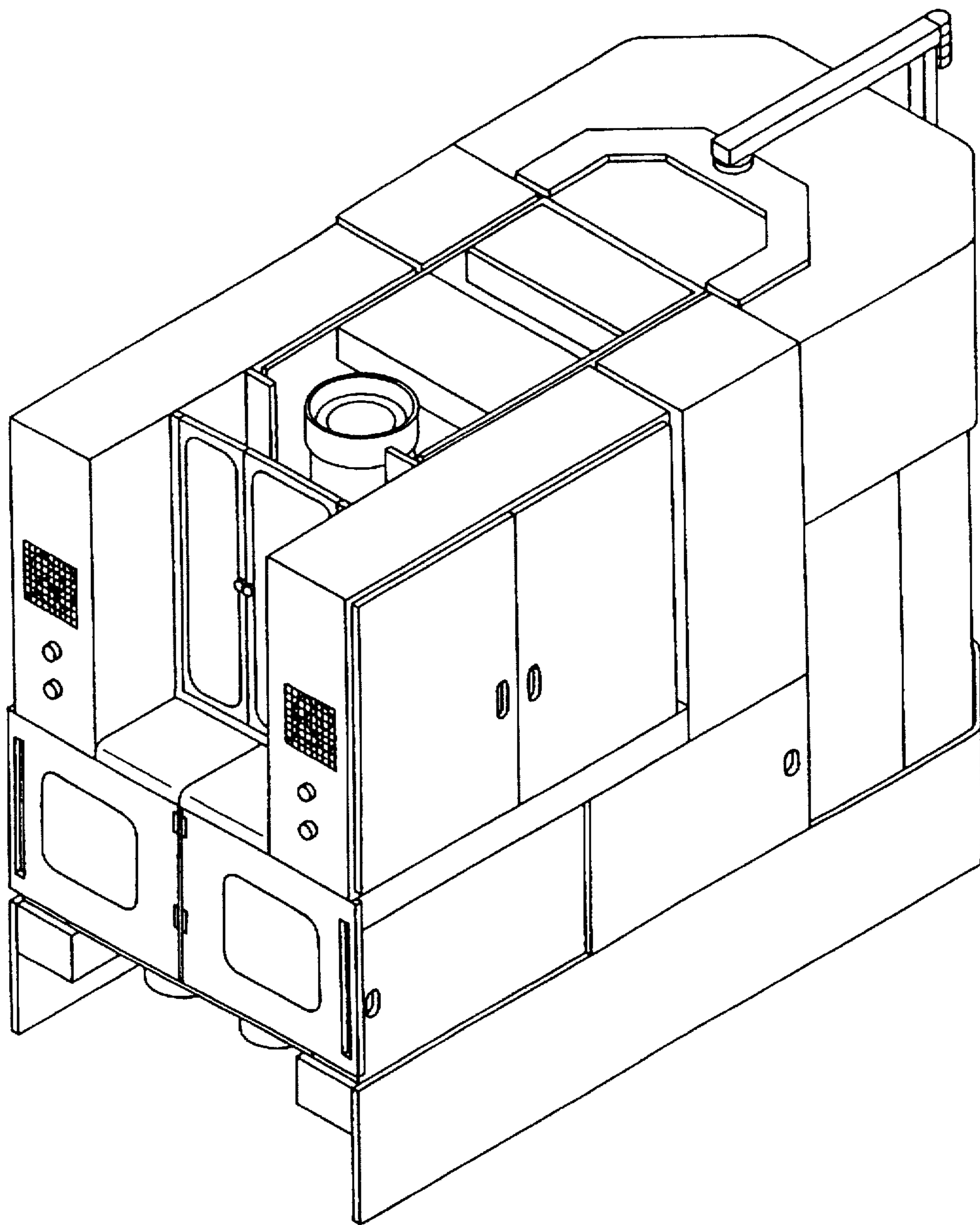

Fig. 44

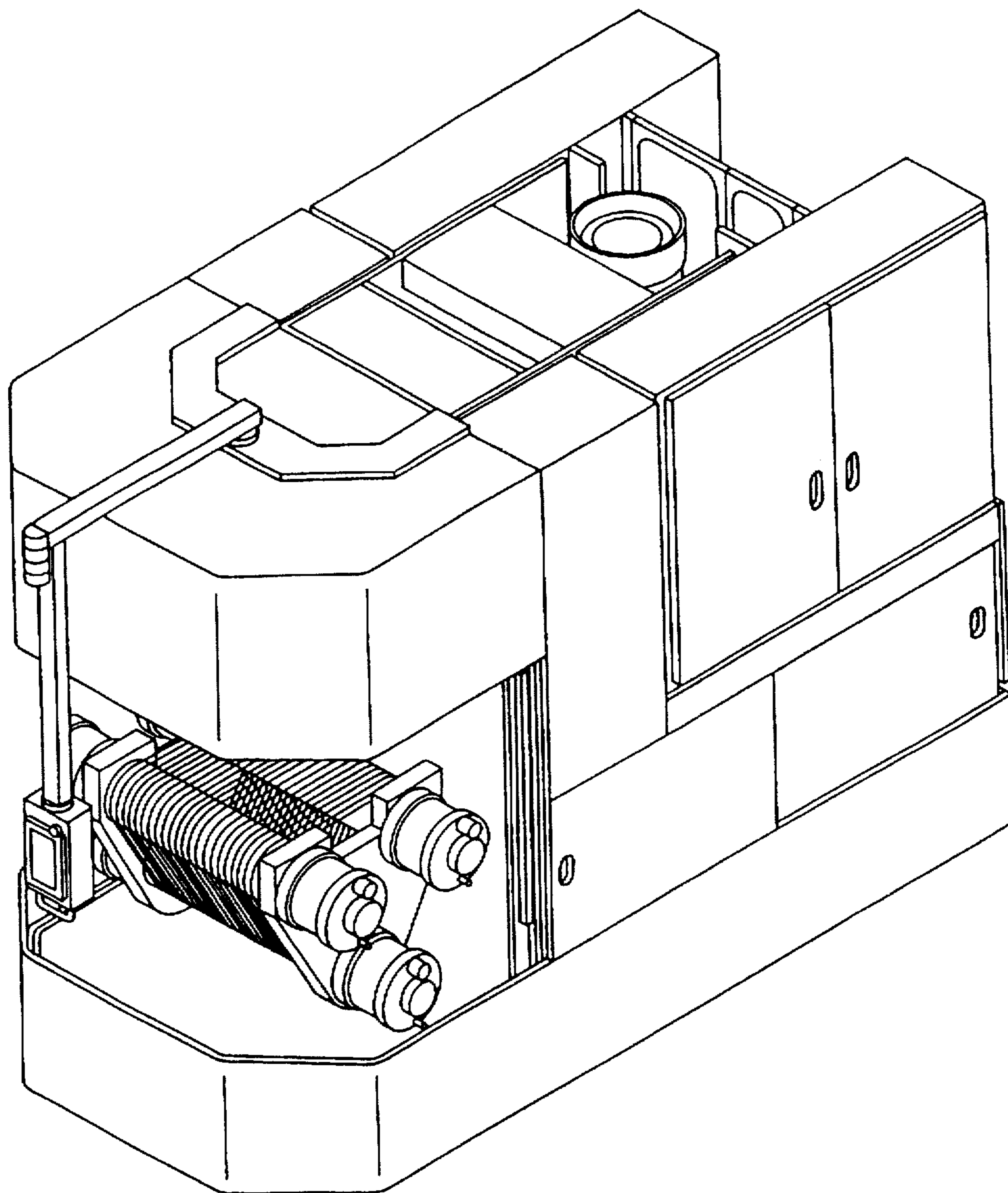

Fig. 45

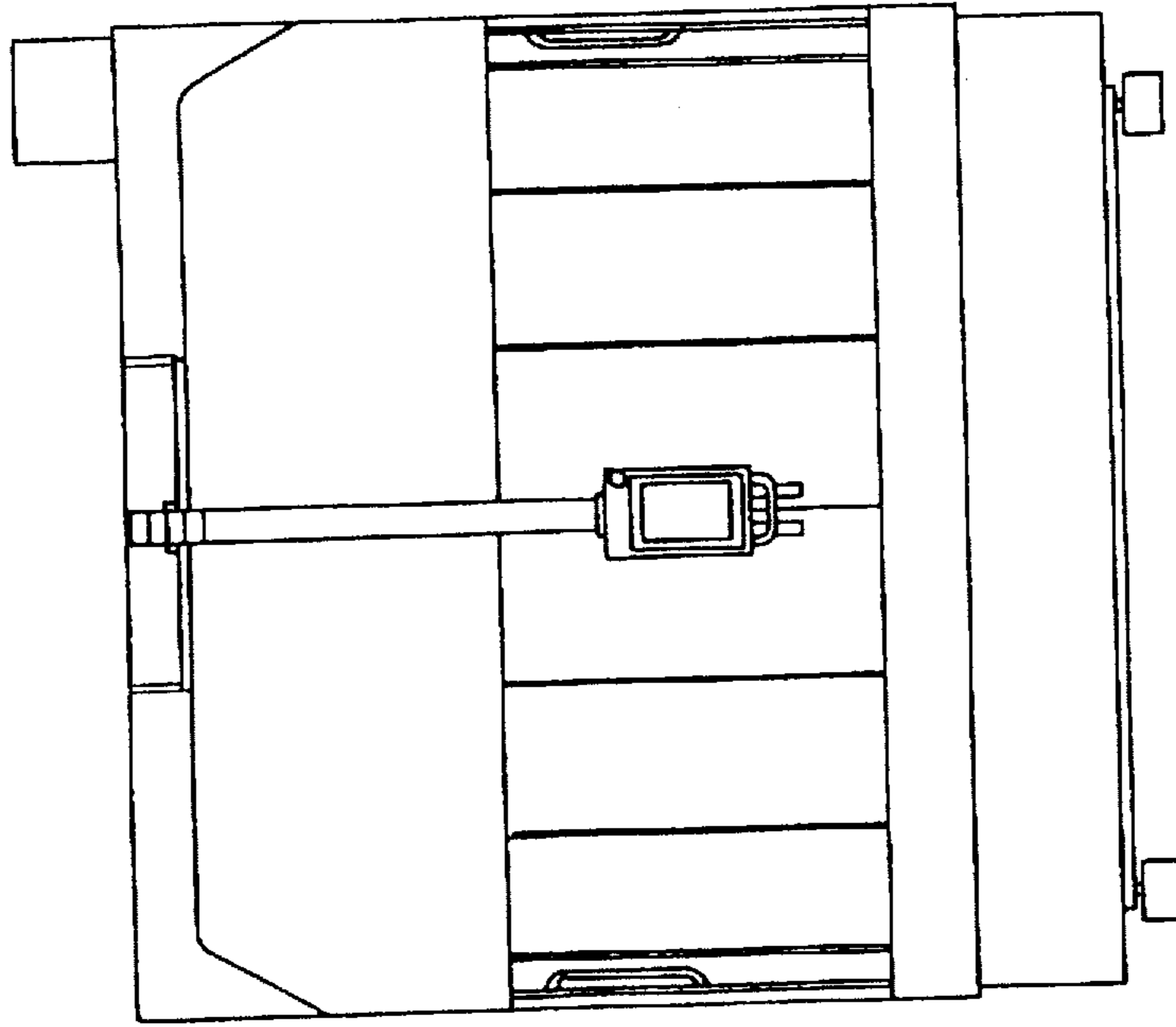

Fig. 46

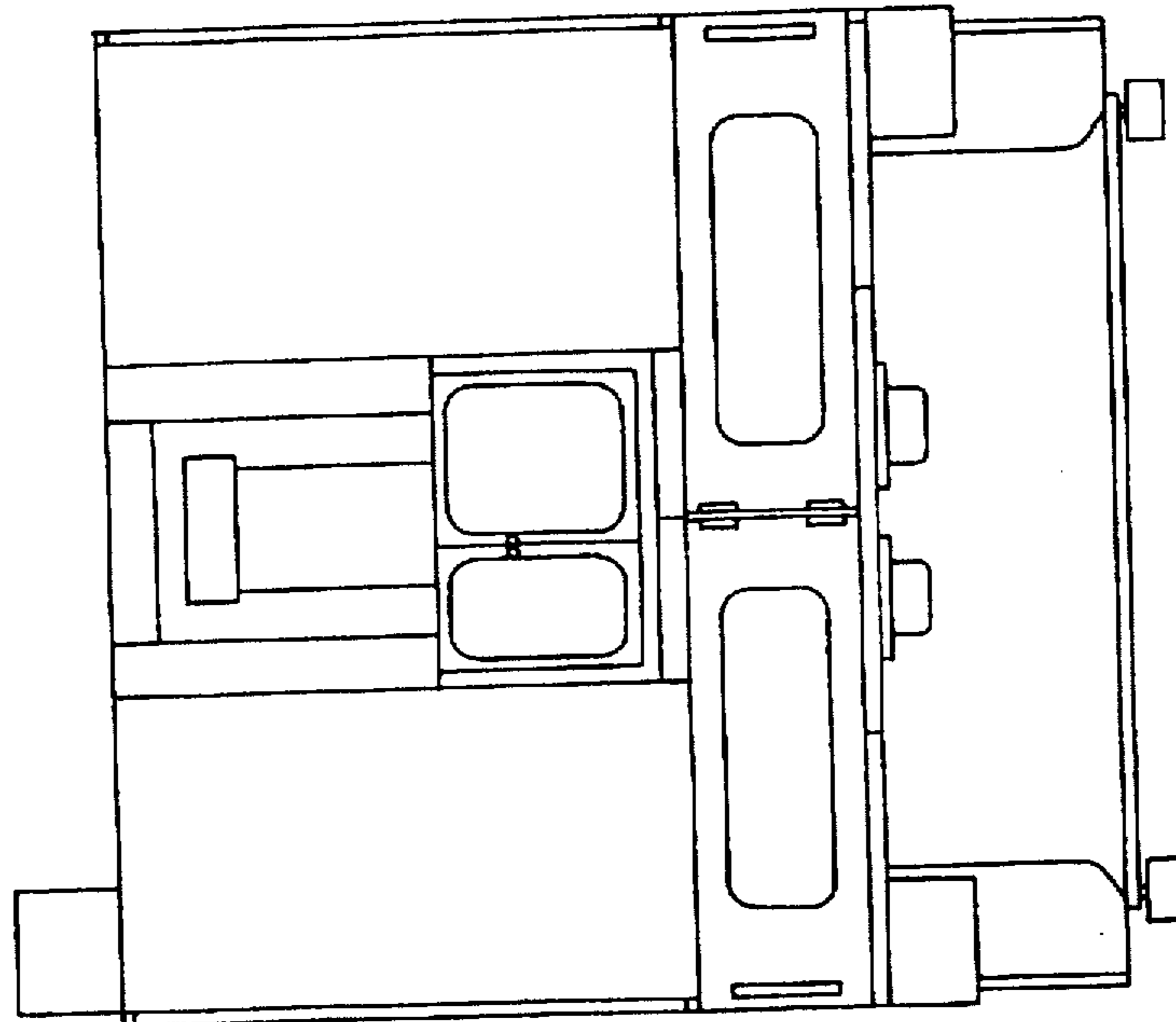

Fig. 47

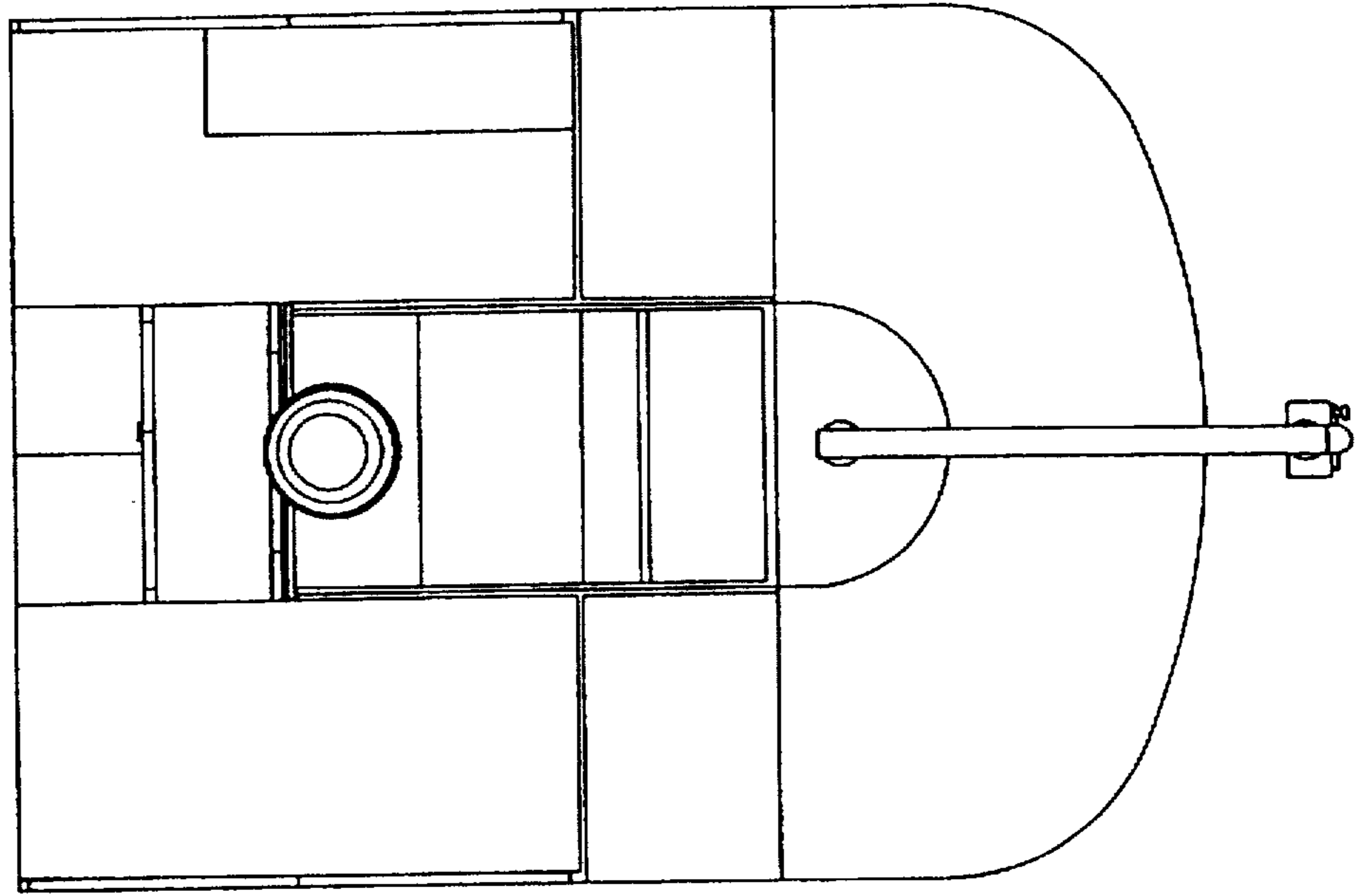

Fig. 48

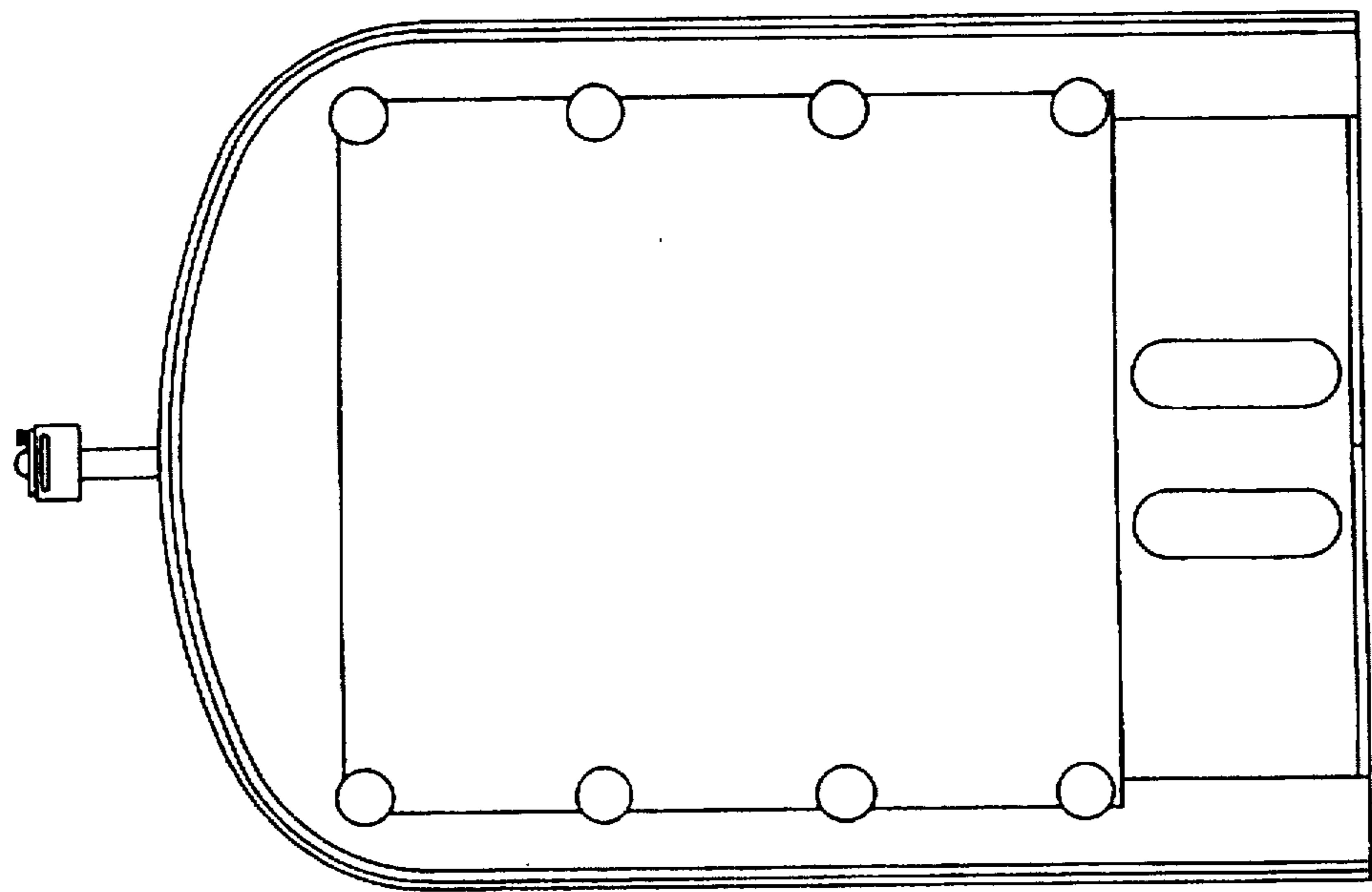

Fig. 49

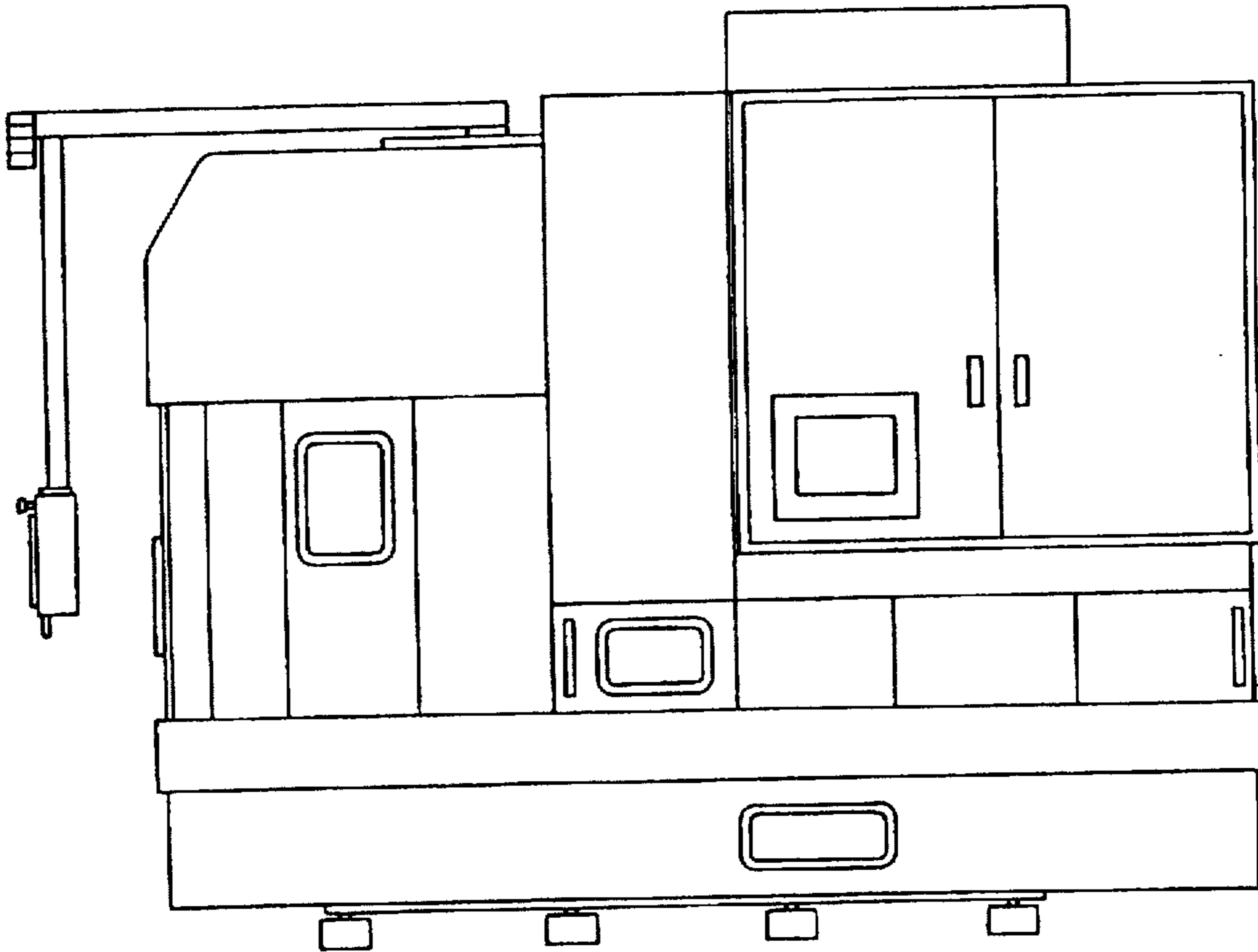

Fig. 50

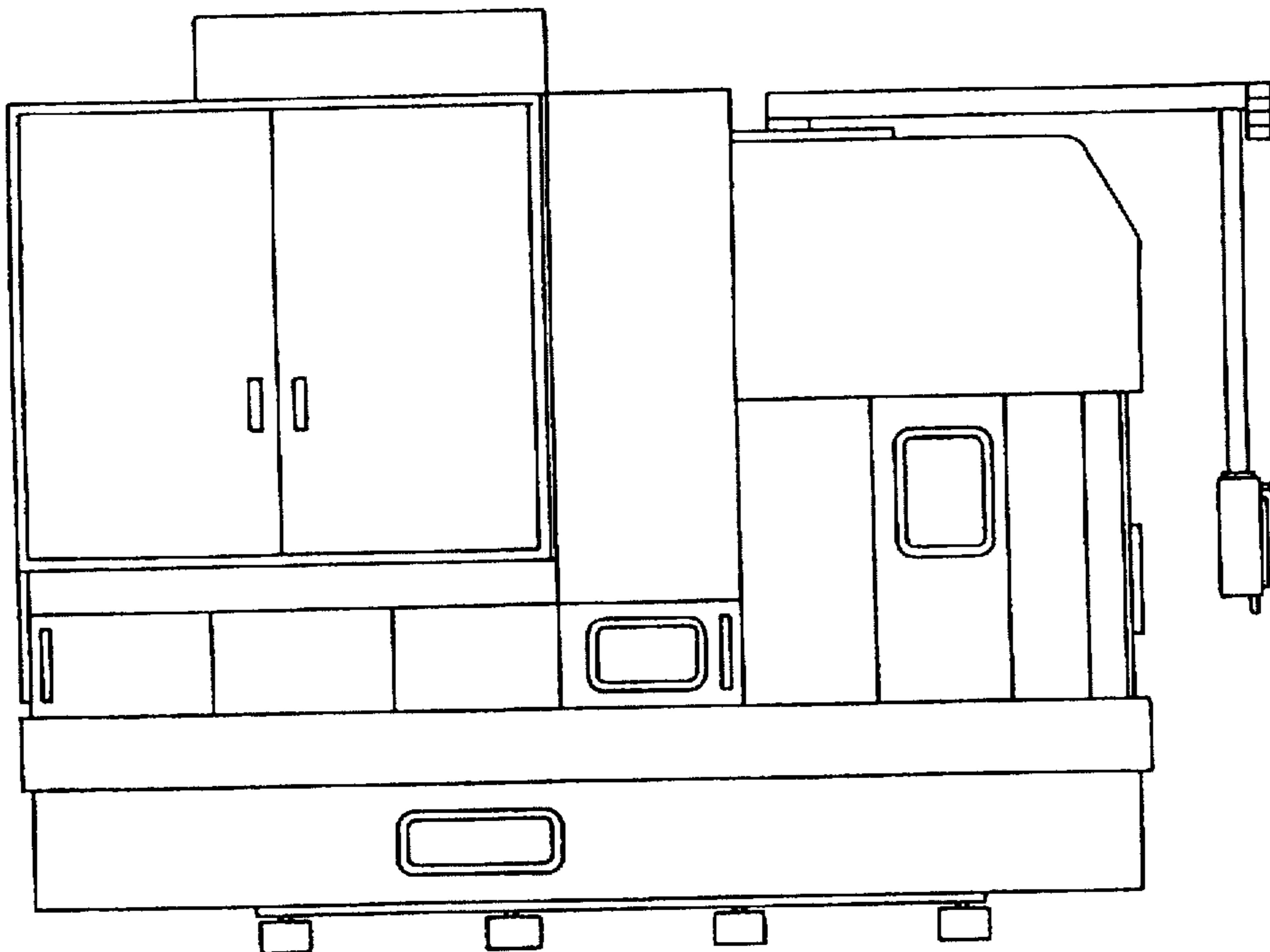

Fig. 51

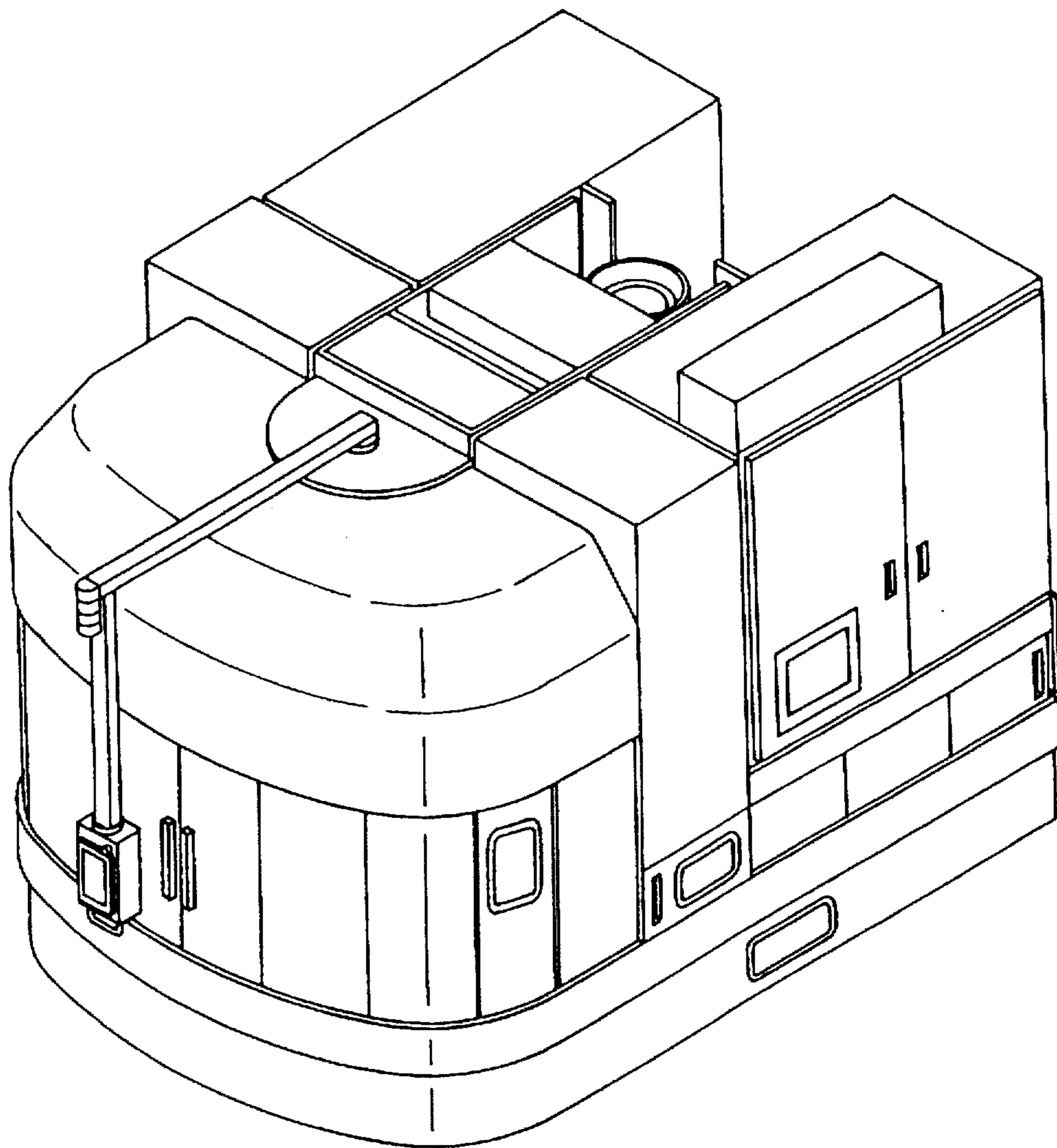

Fig. 52

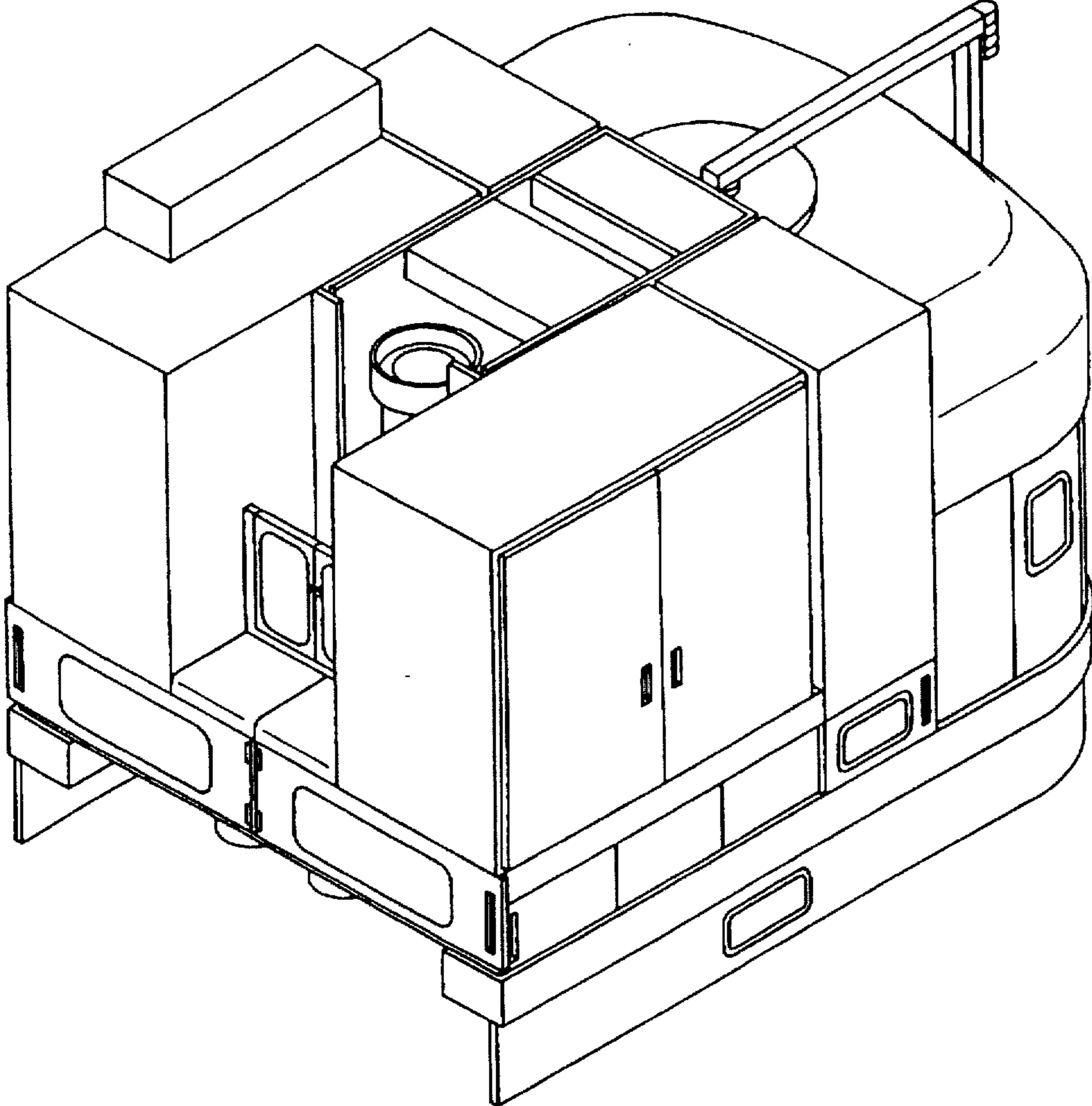

Fig. 53

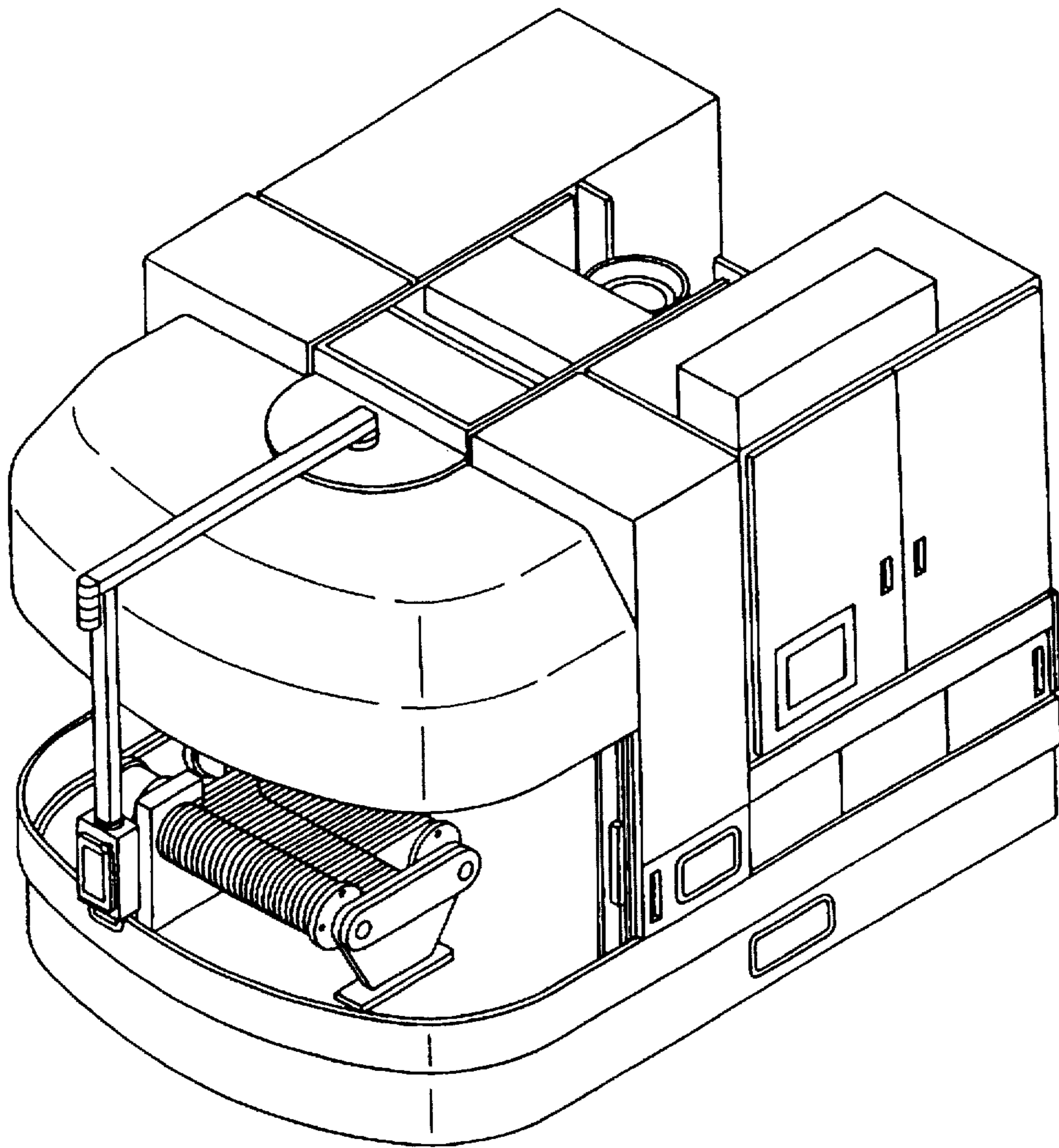

Fig. 54

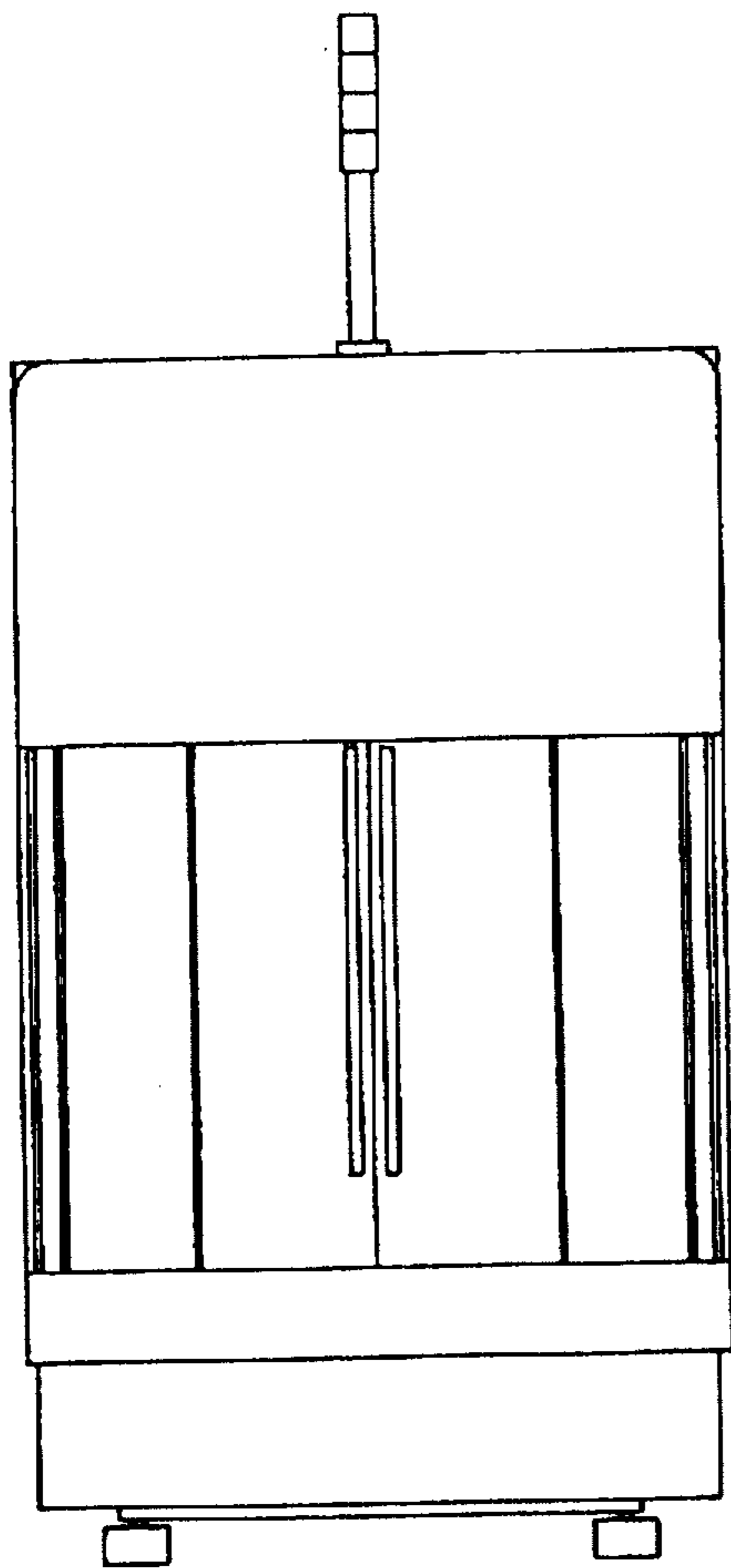

Fig. 55

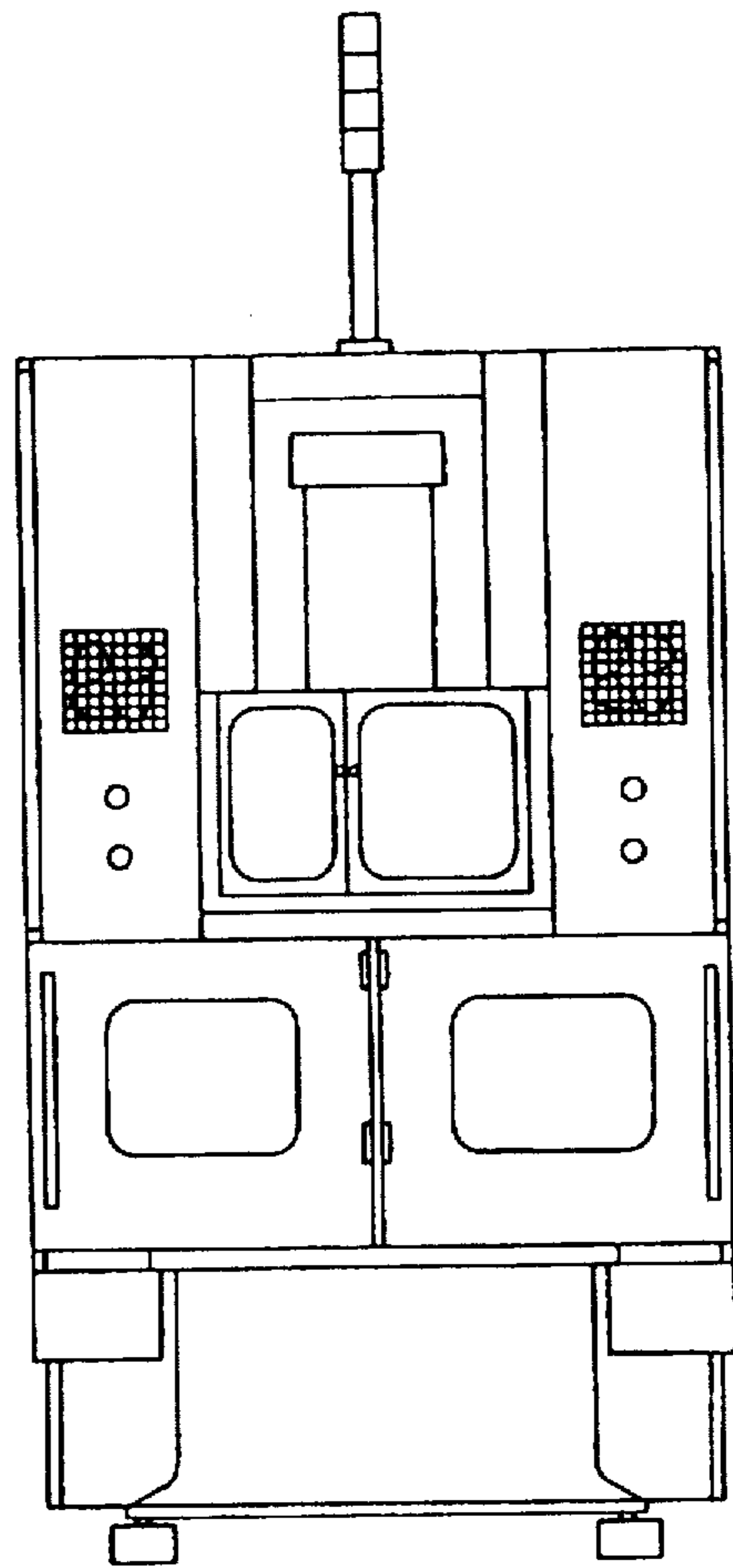

Fig. 56

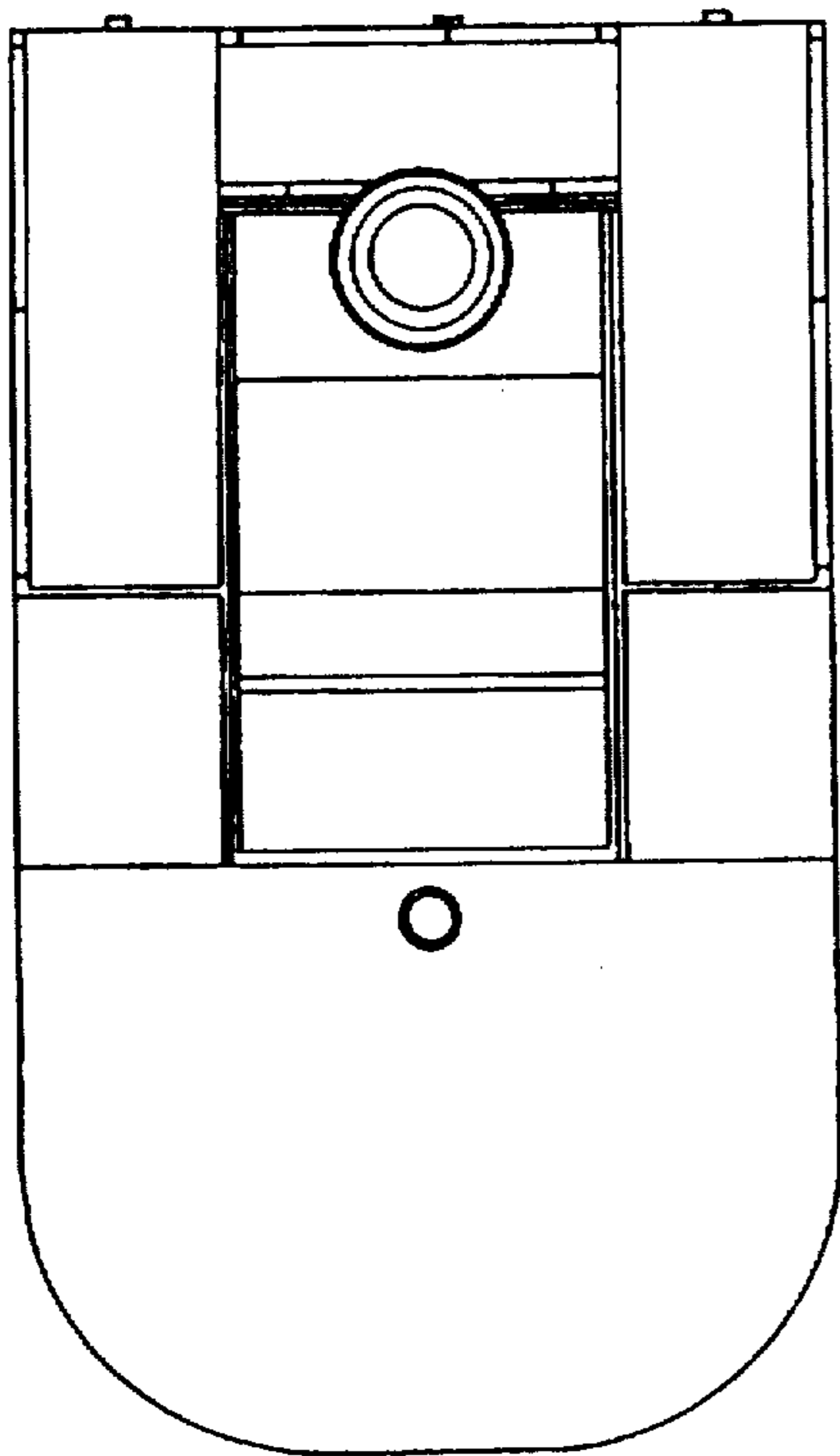

Fig. 57

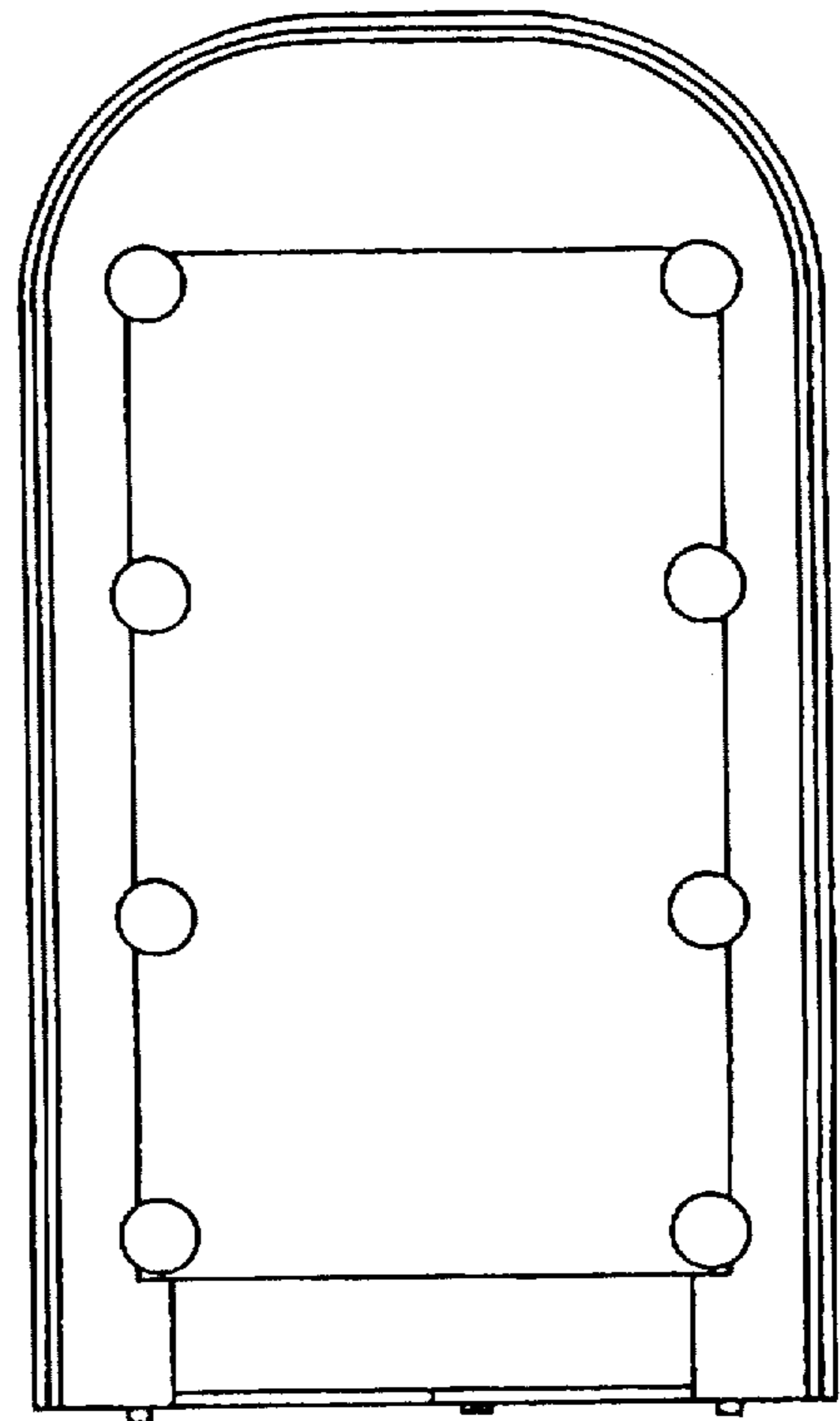

Fig. 58

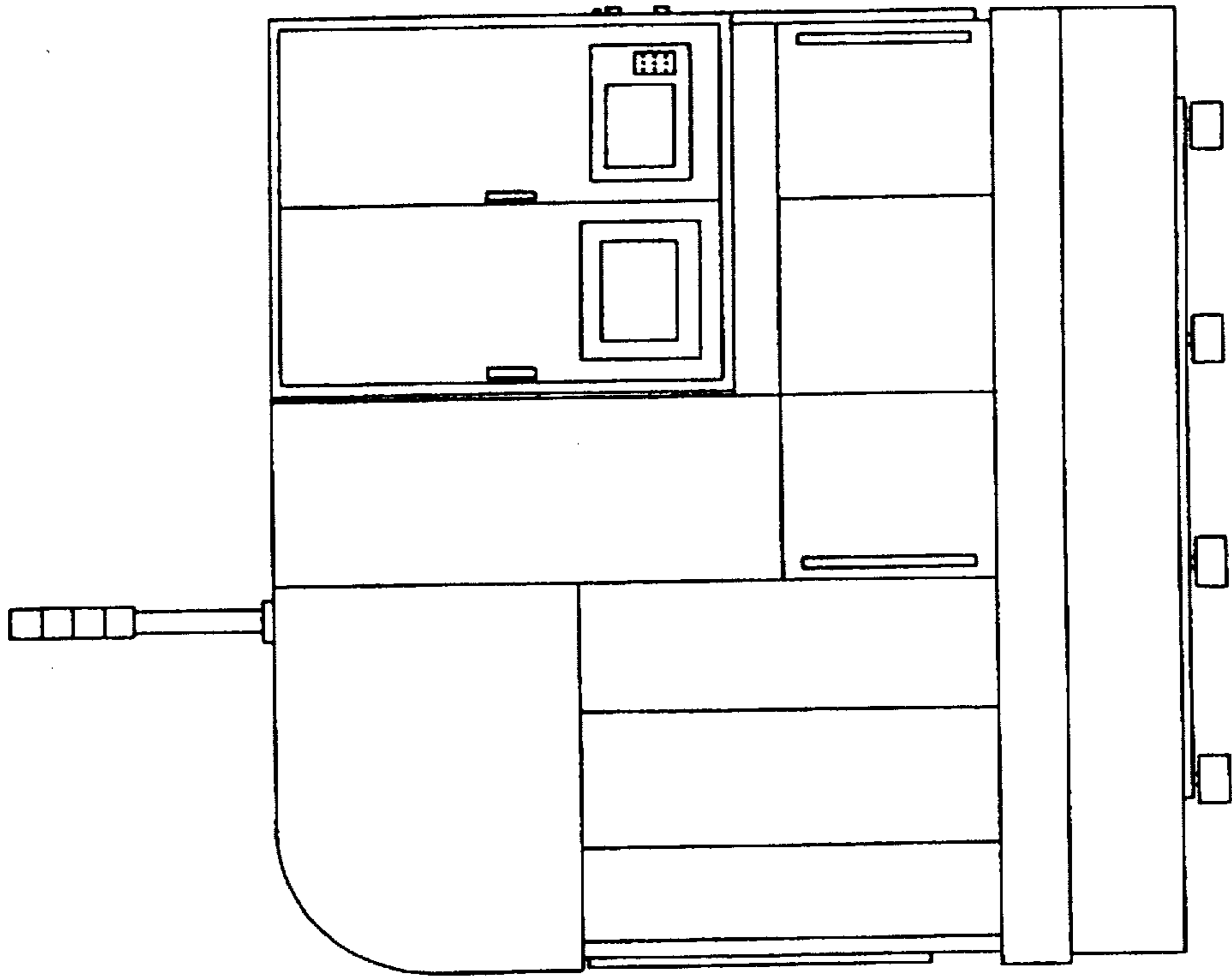

Fig. 59

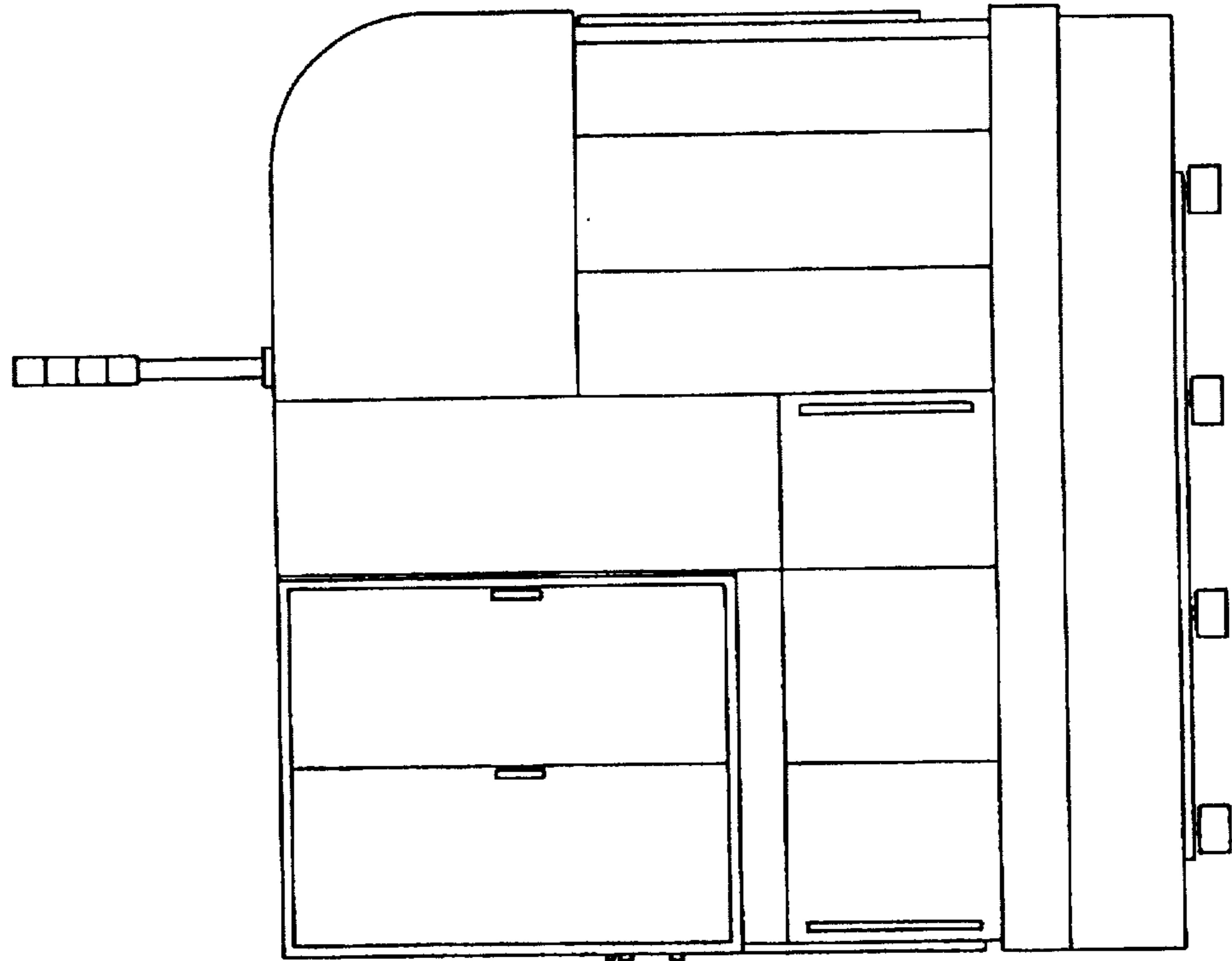

Fig. 60

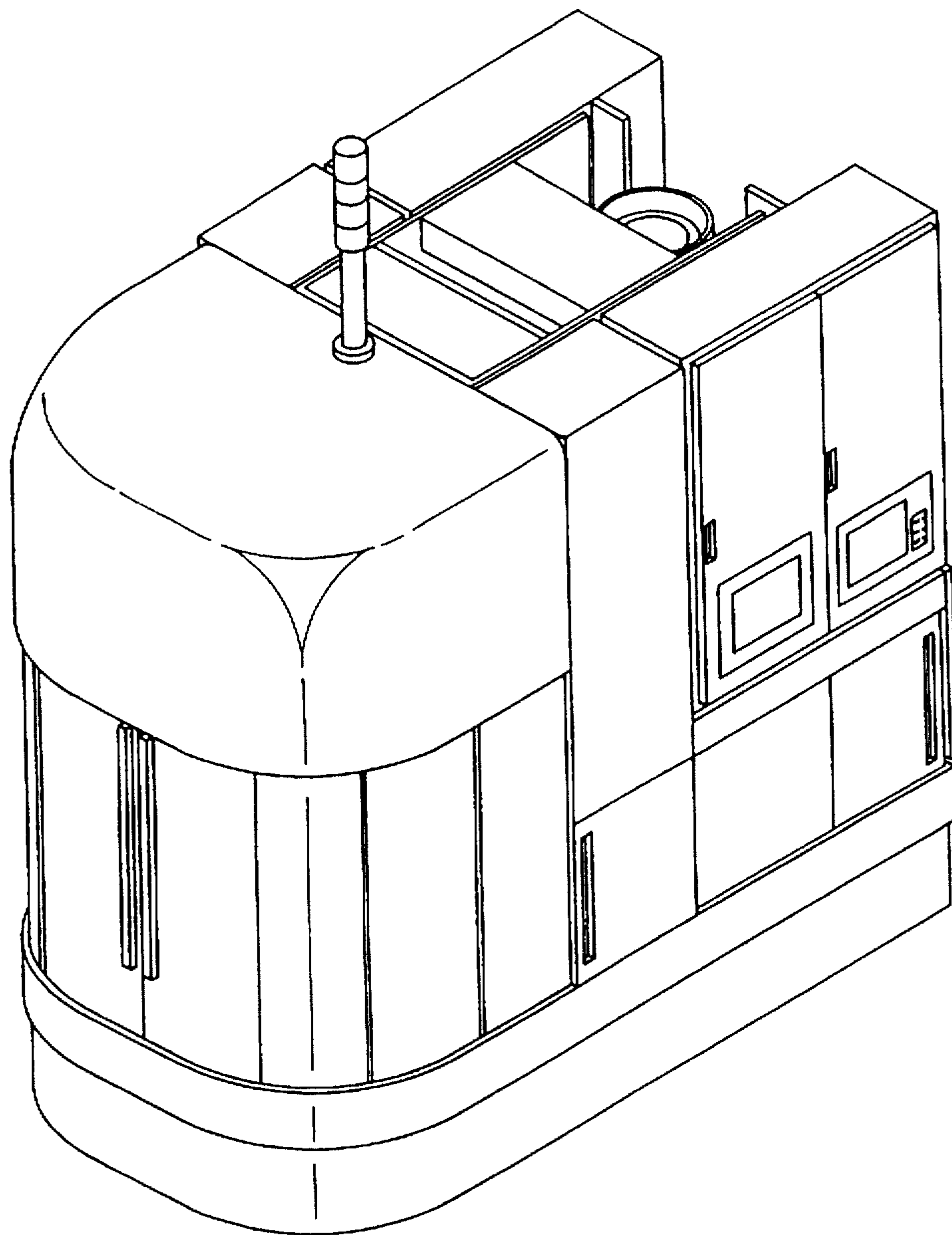

Fig. 61

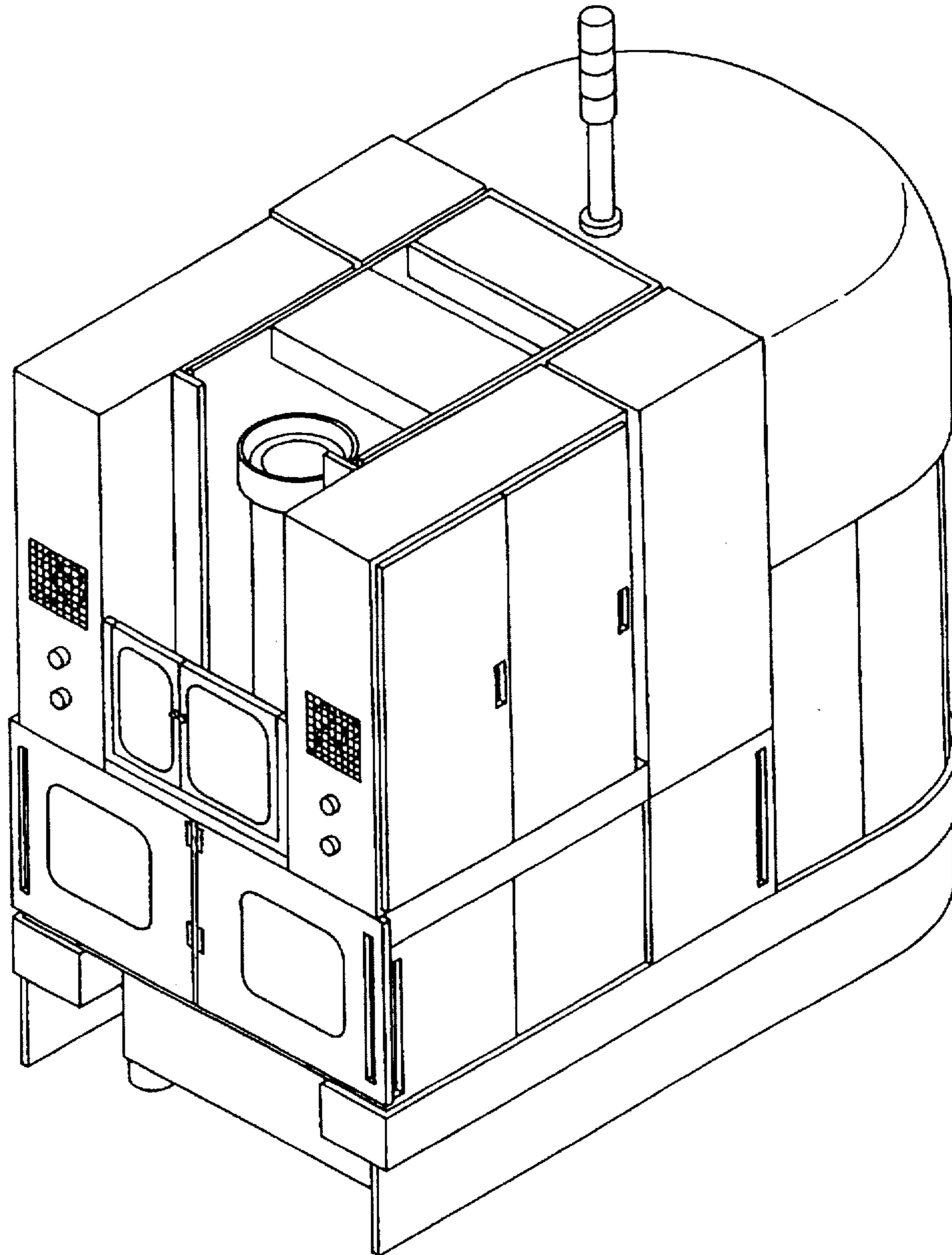

Fig. 62

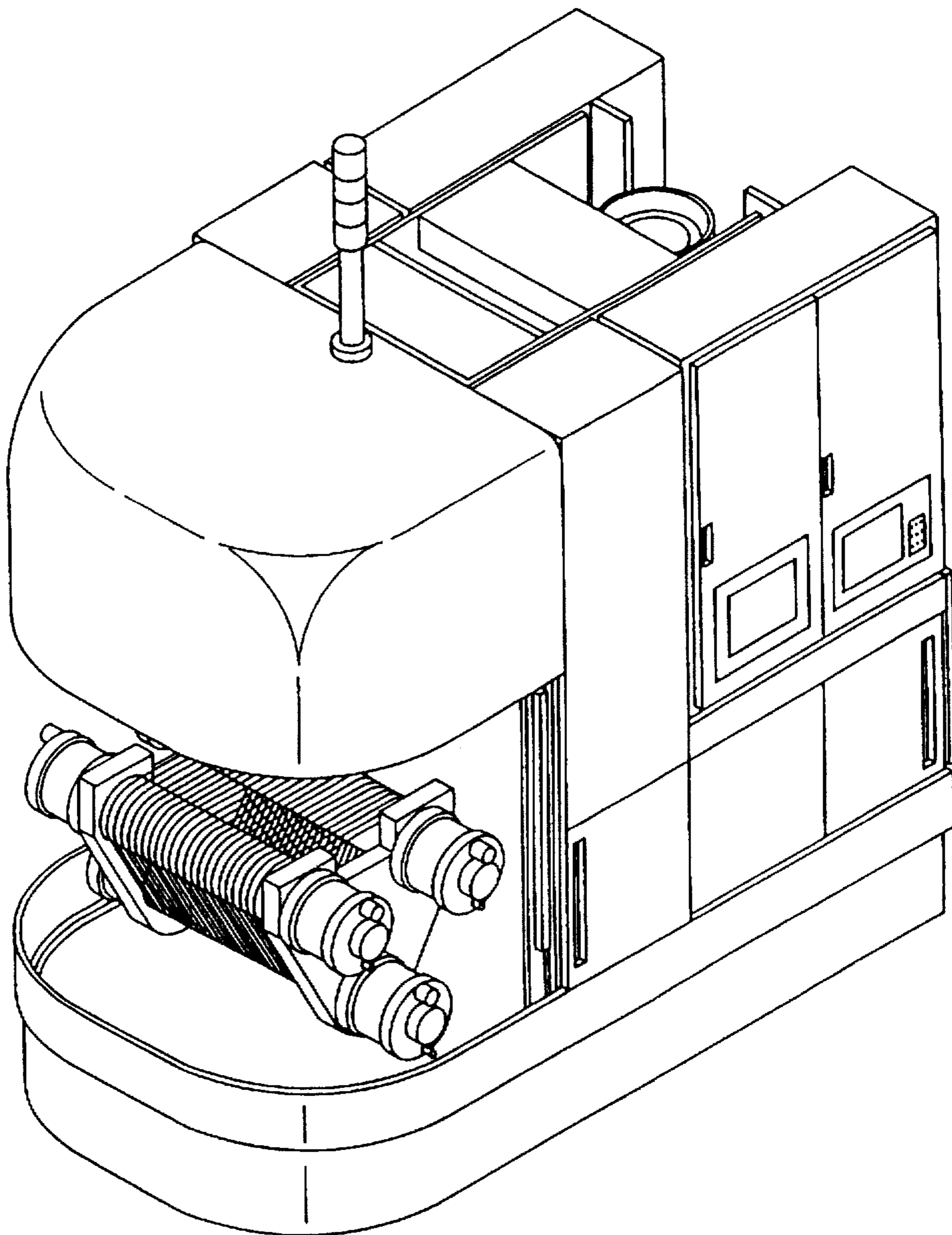

Fig. 63

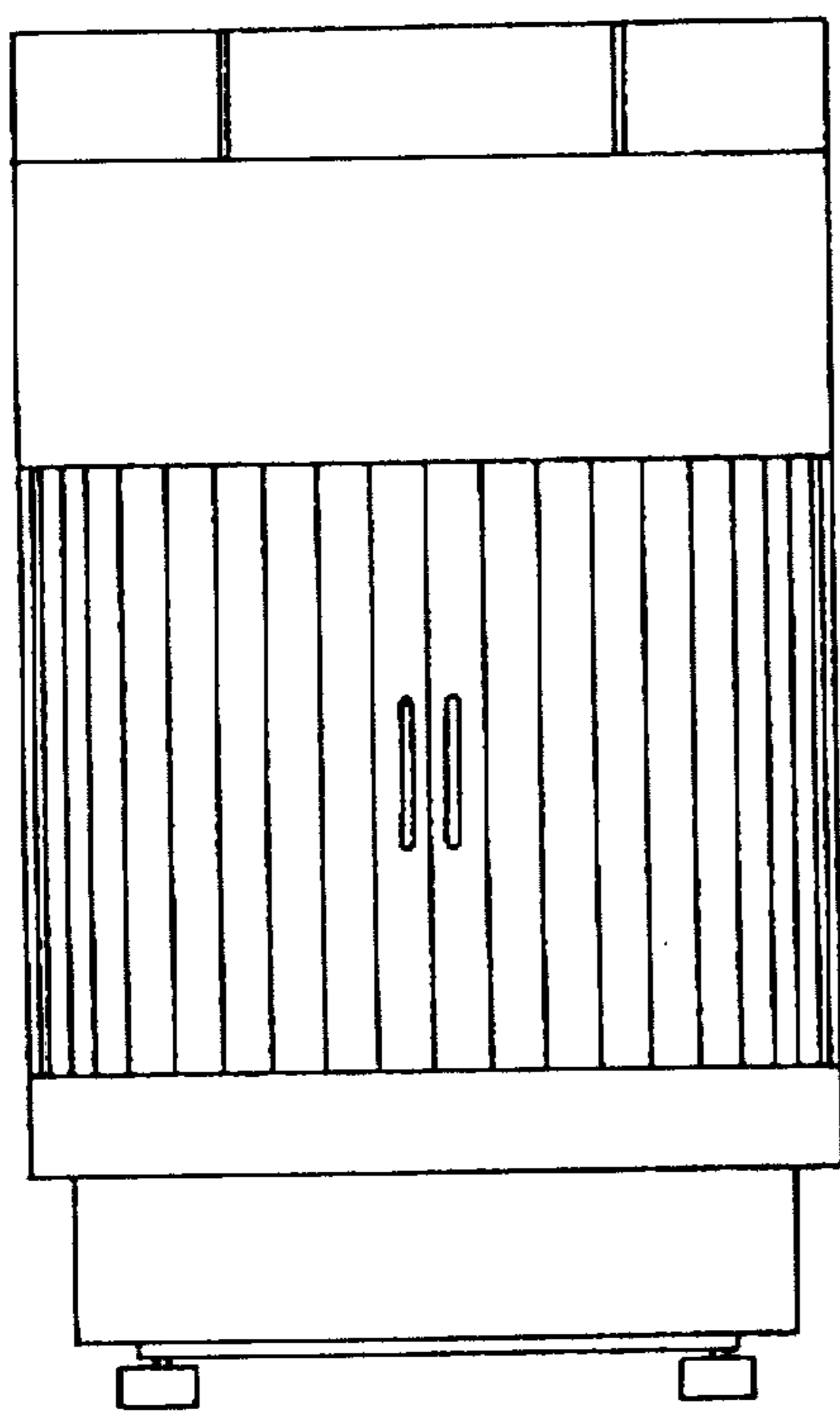

Fig. 64

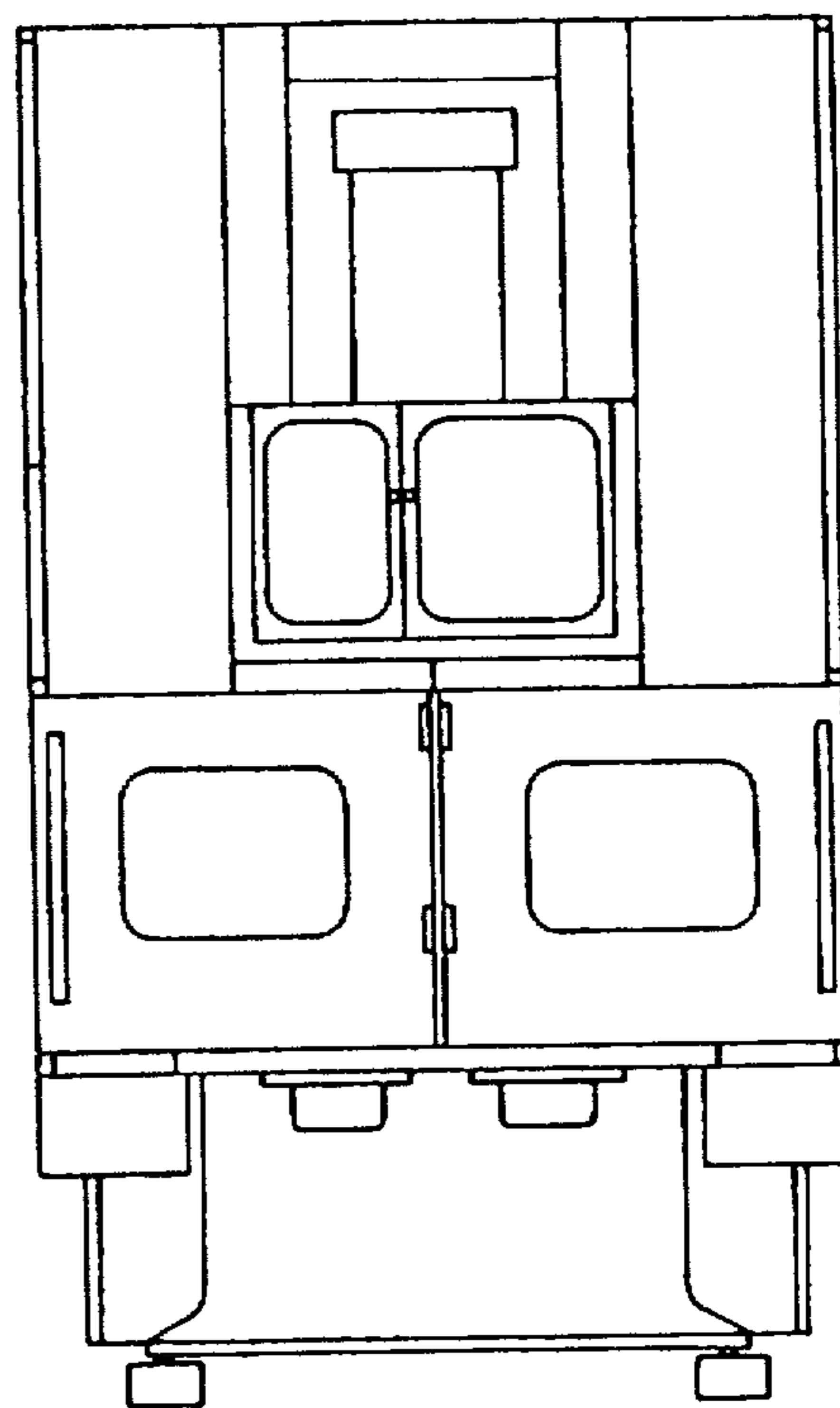

Fig. 65

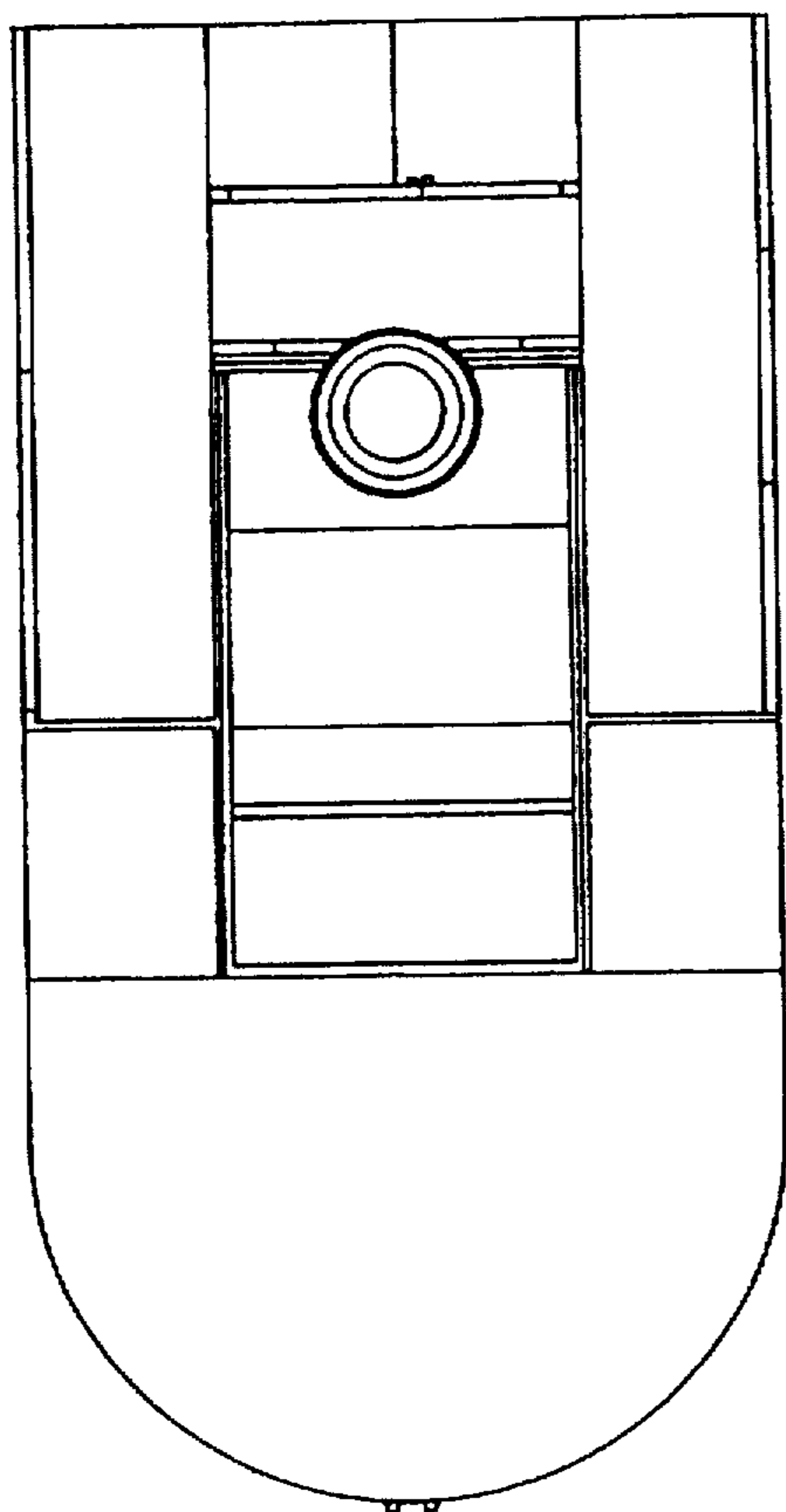

Fig. 66

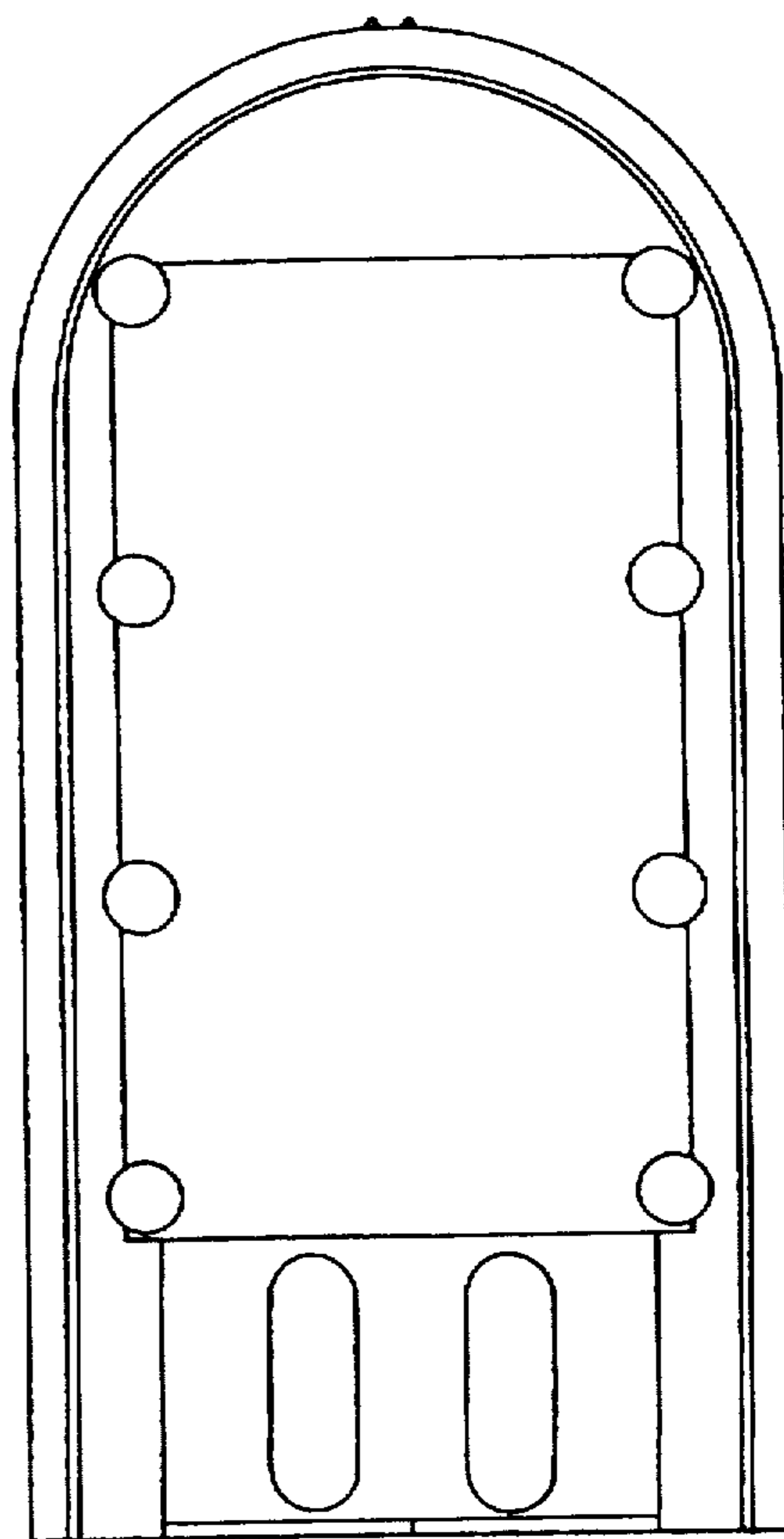

Fig. 67

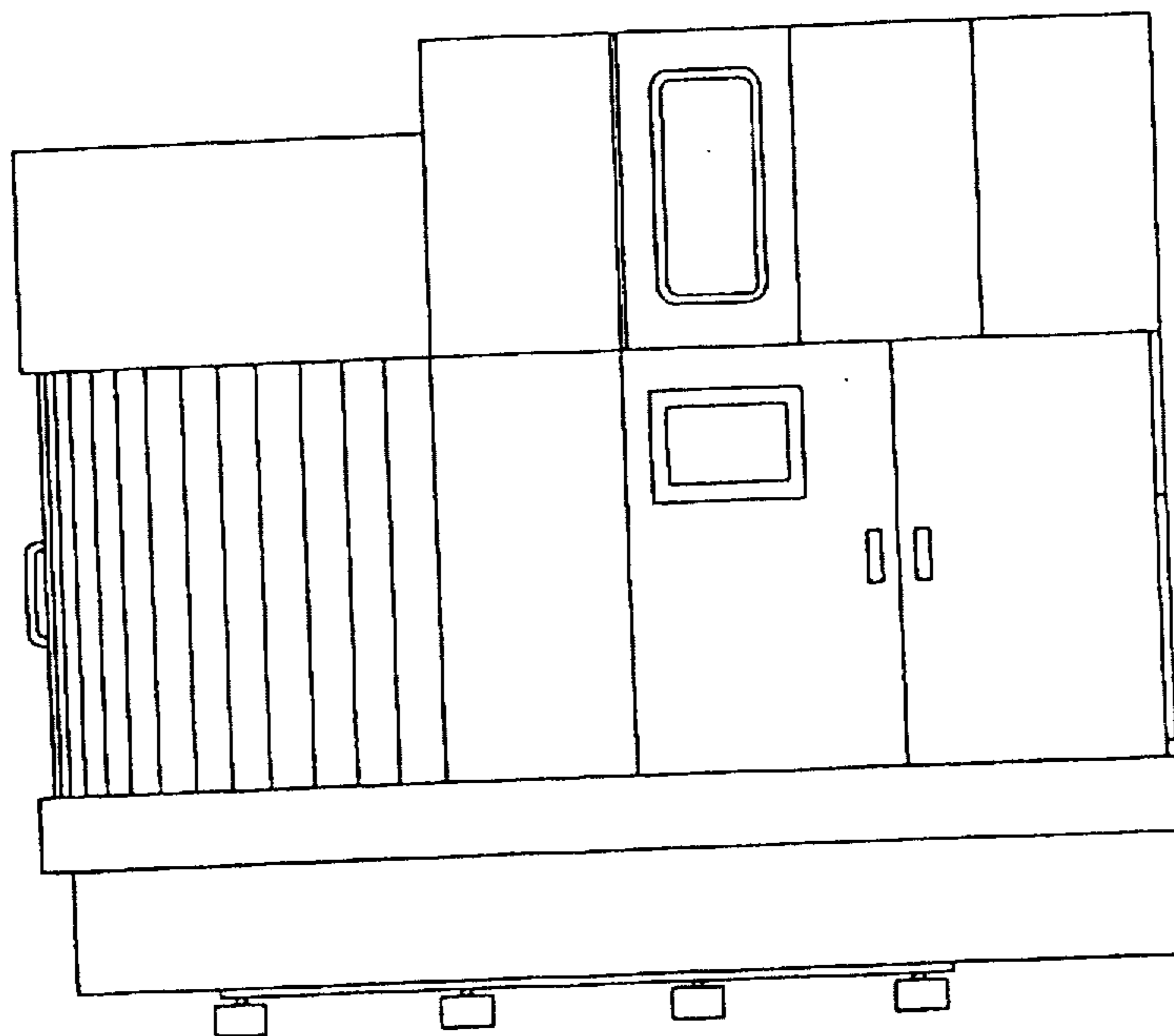

Fig. 68

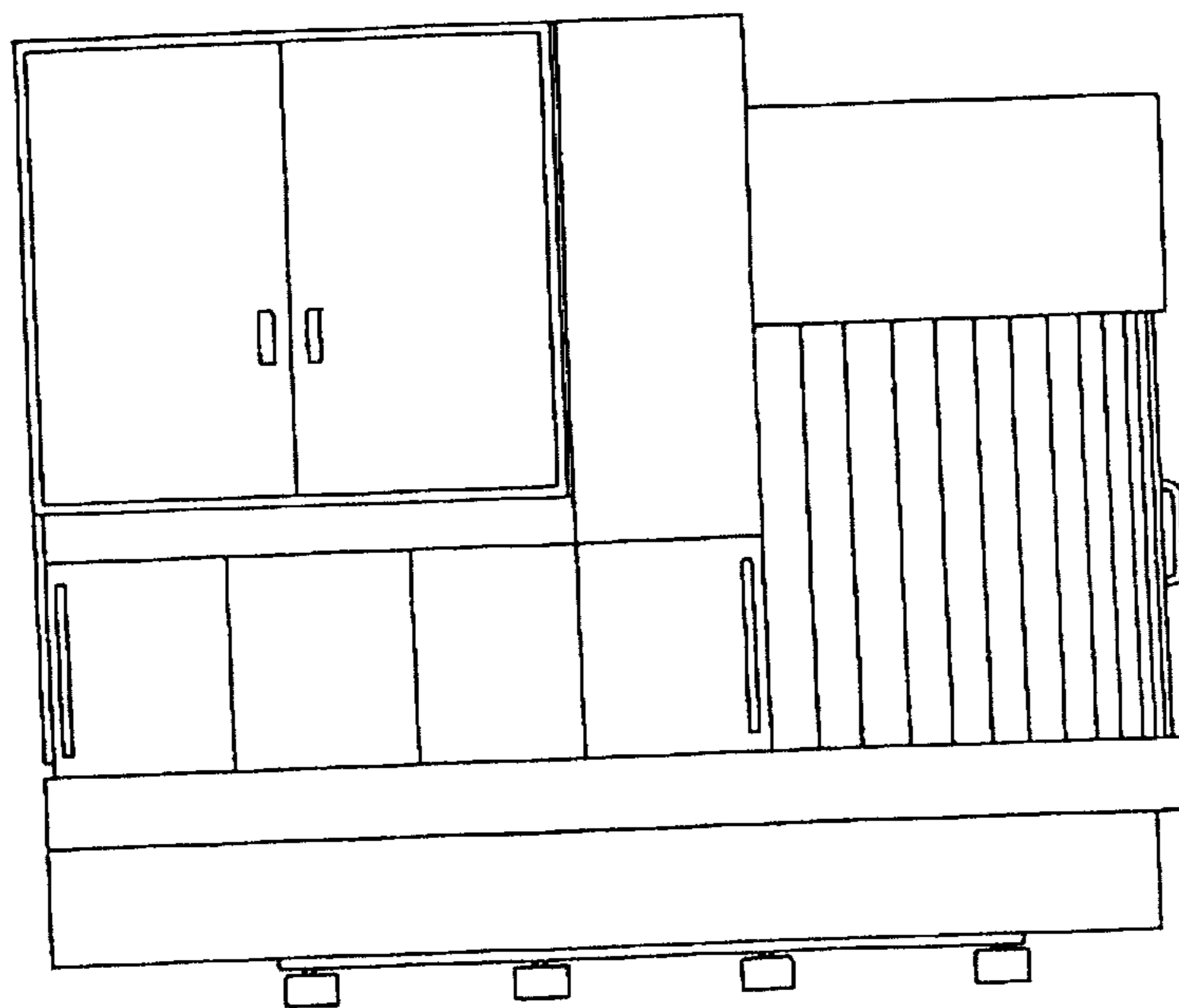

Fig. 69

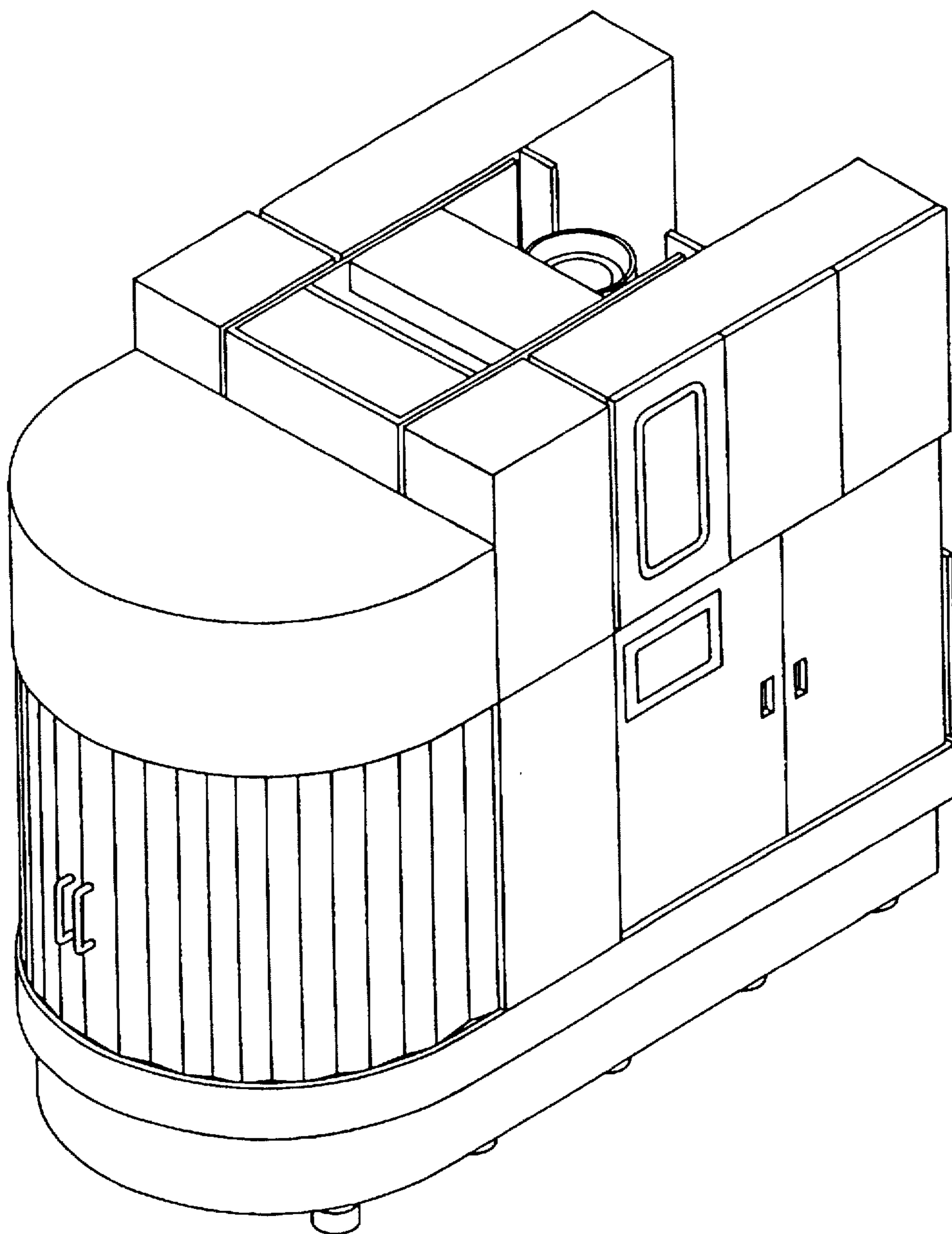

Fig. 70

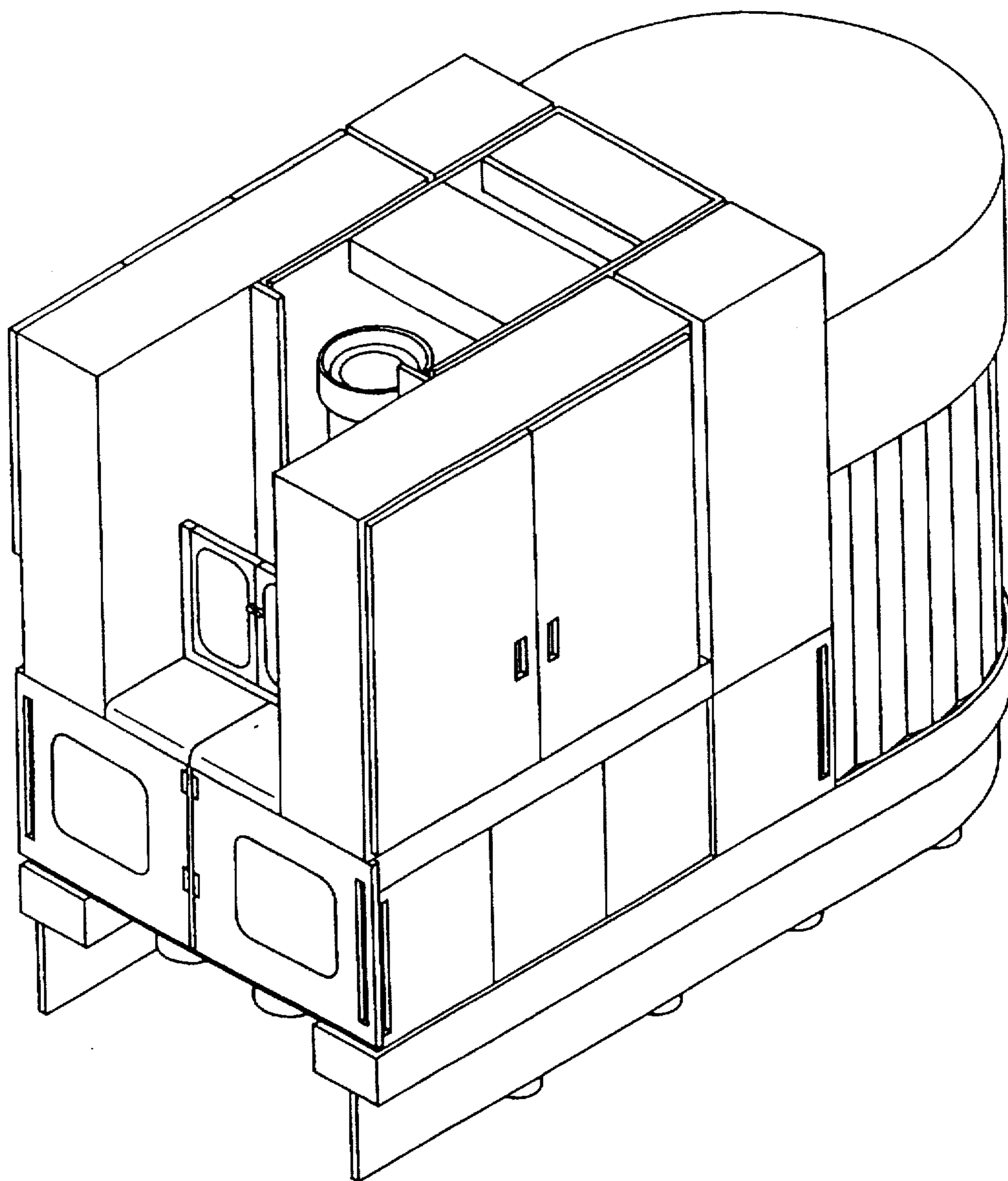

Fig. 71

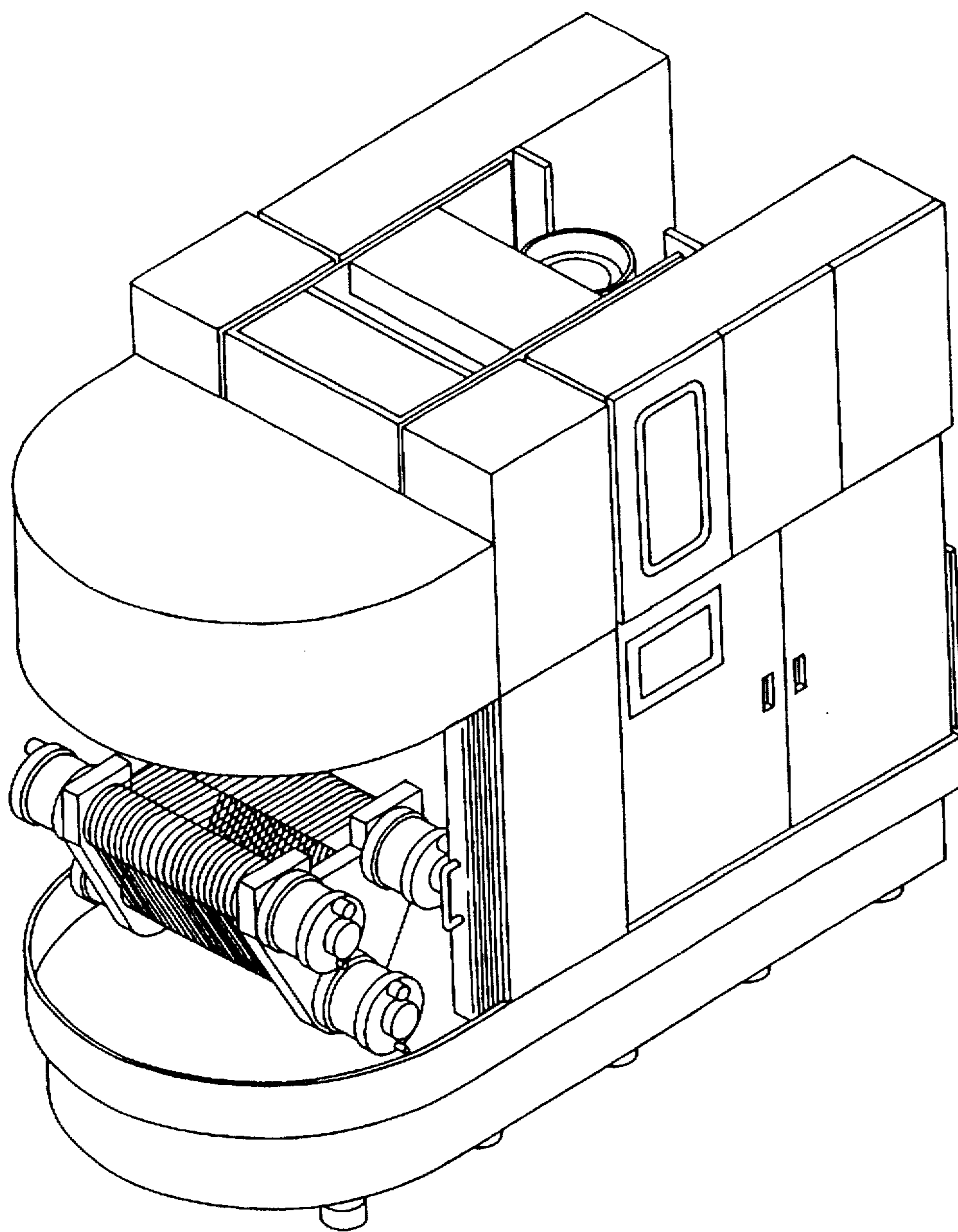

Fig. 72

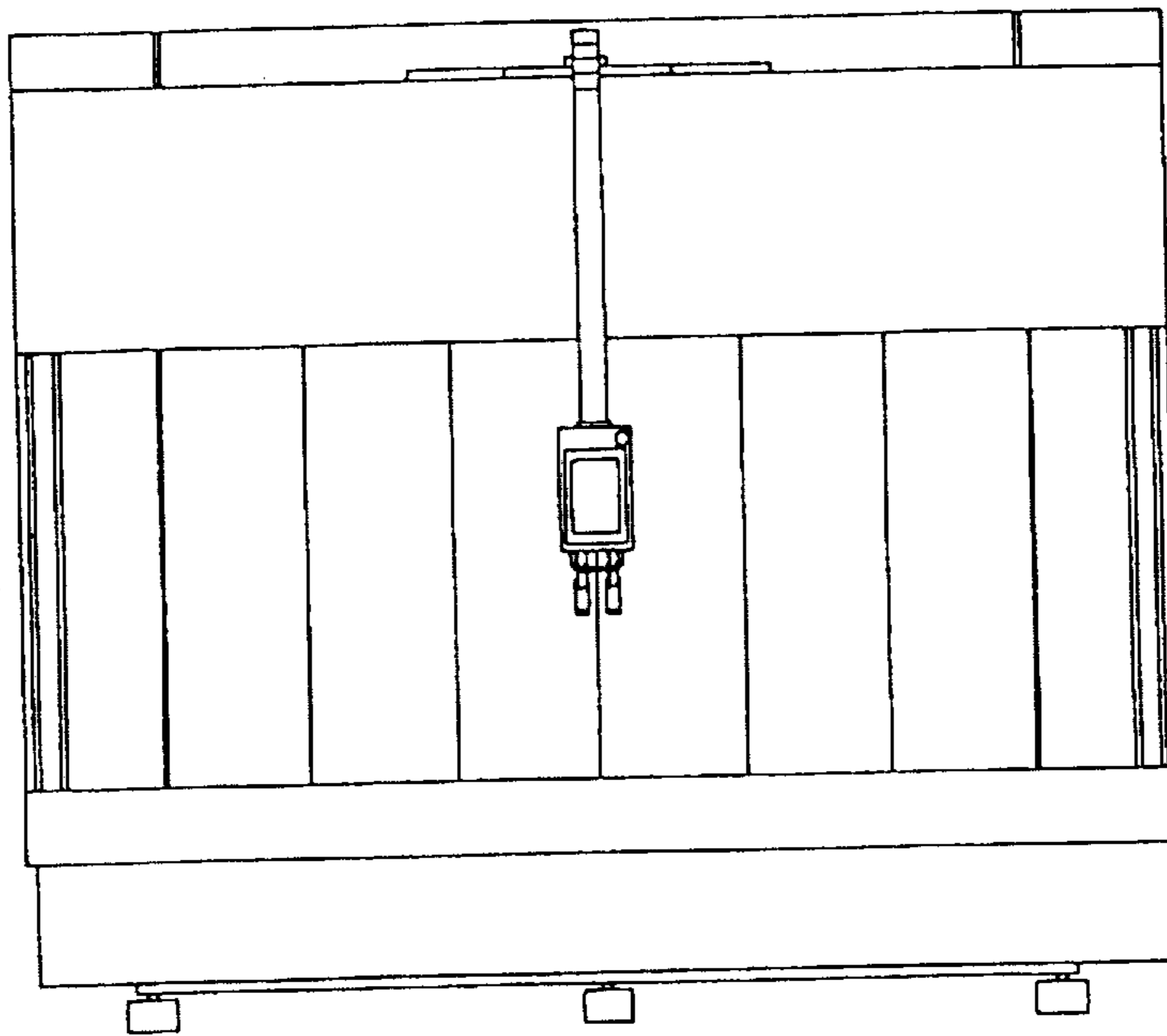

Fig. 73

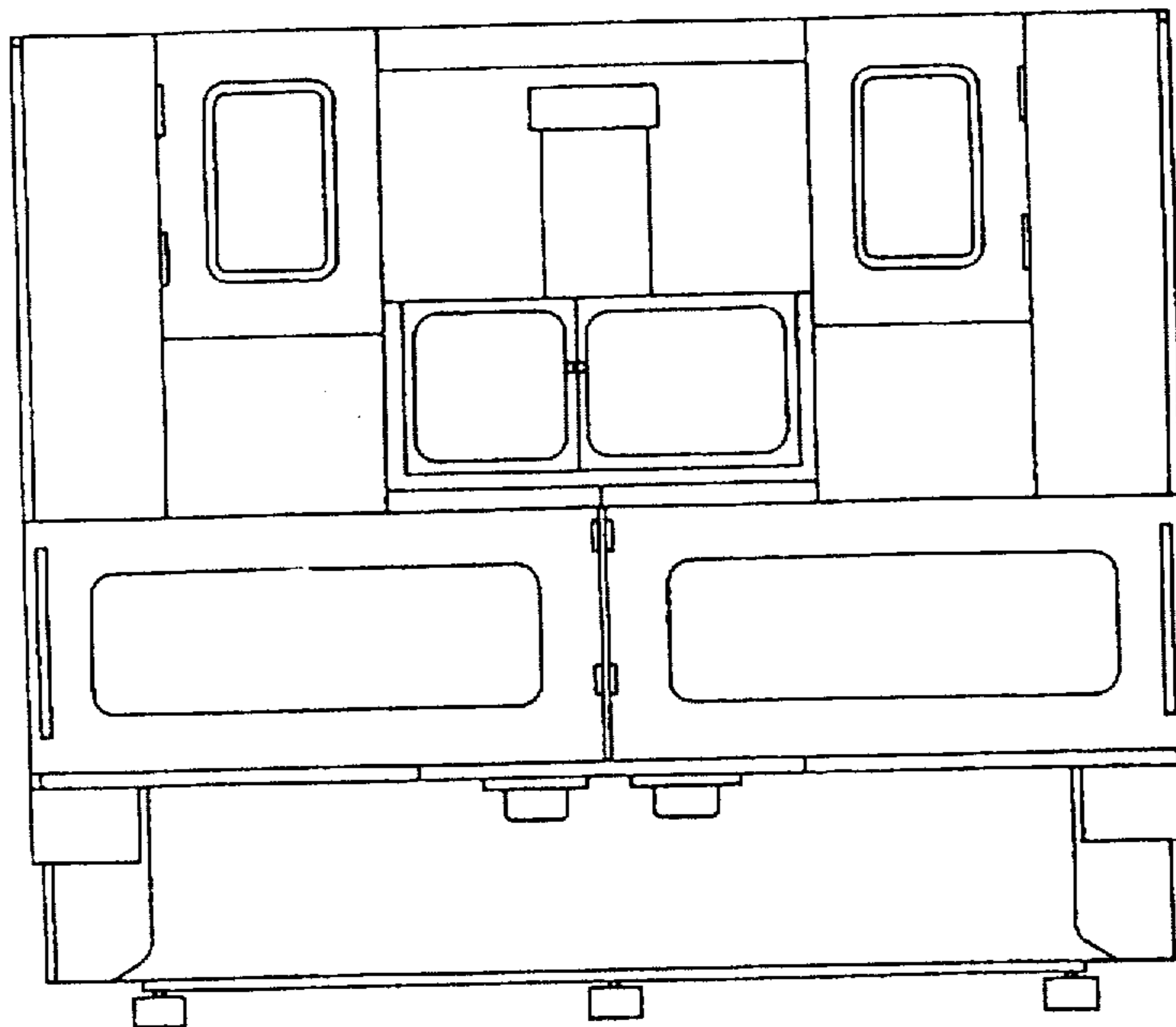

Fig. 74

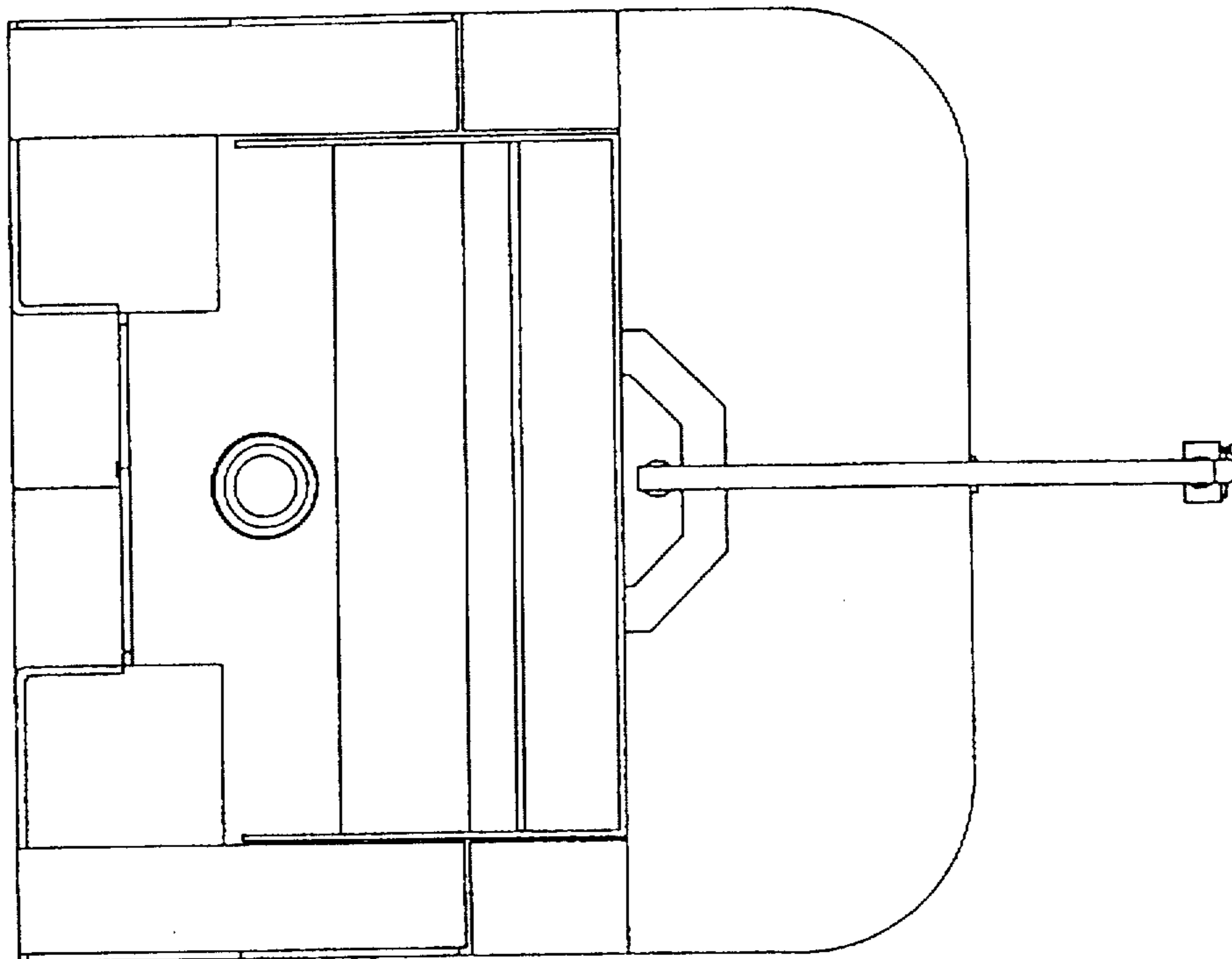

Fig. 75

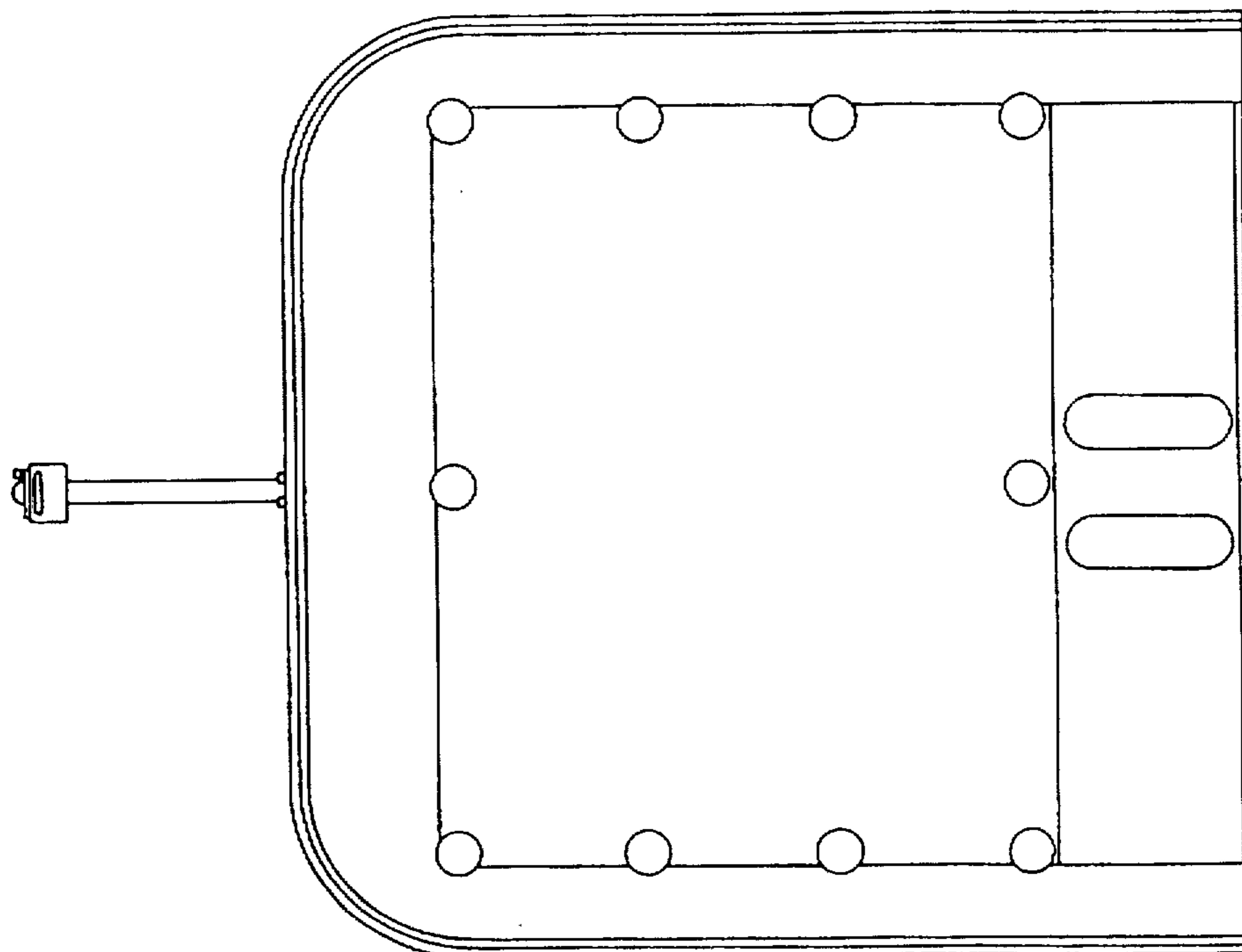

Fig. 76

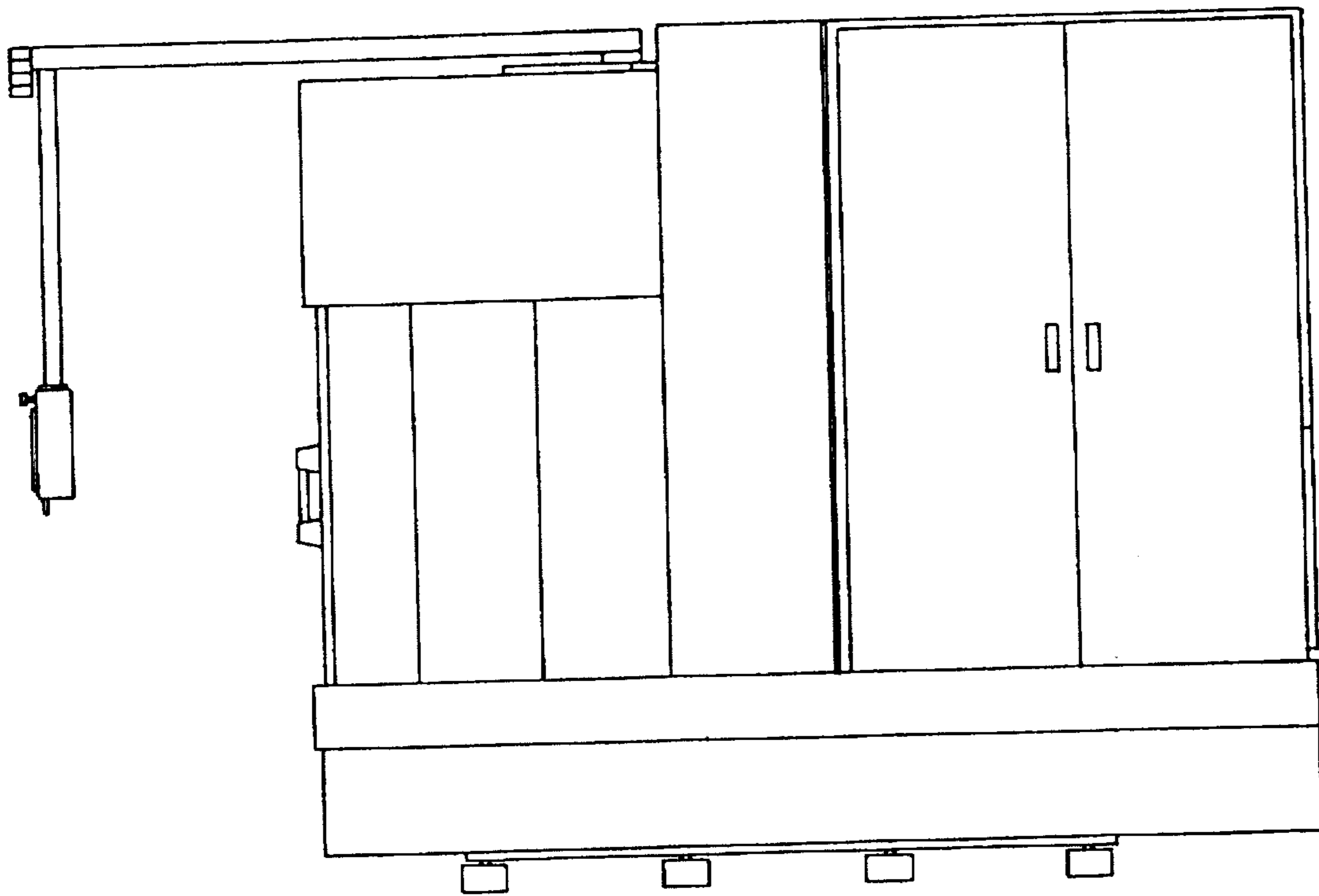

Fig. 77

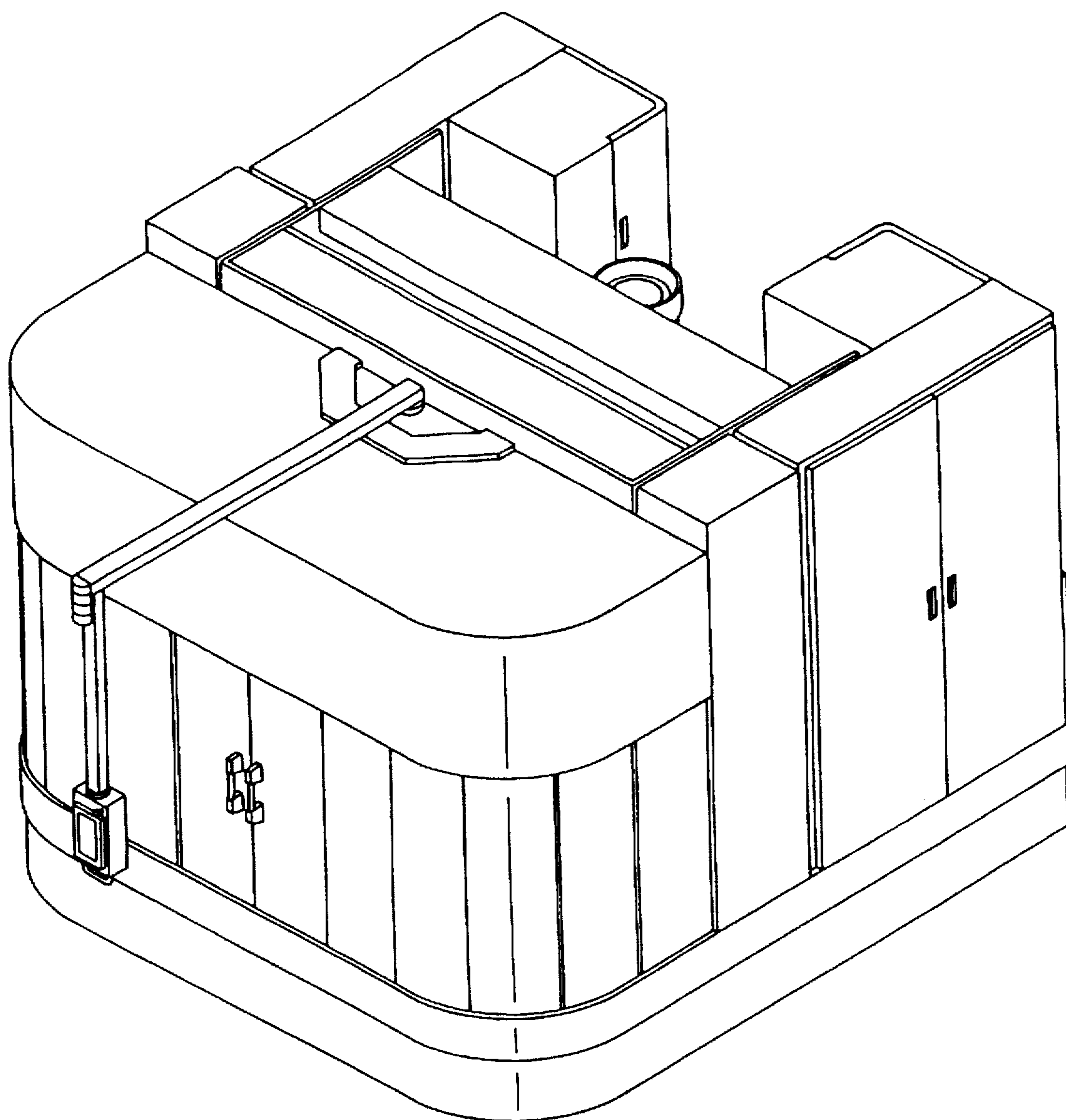

Fig. 78

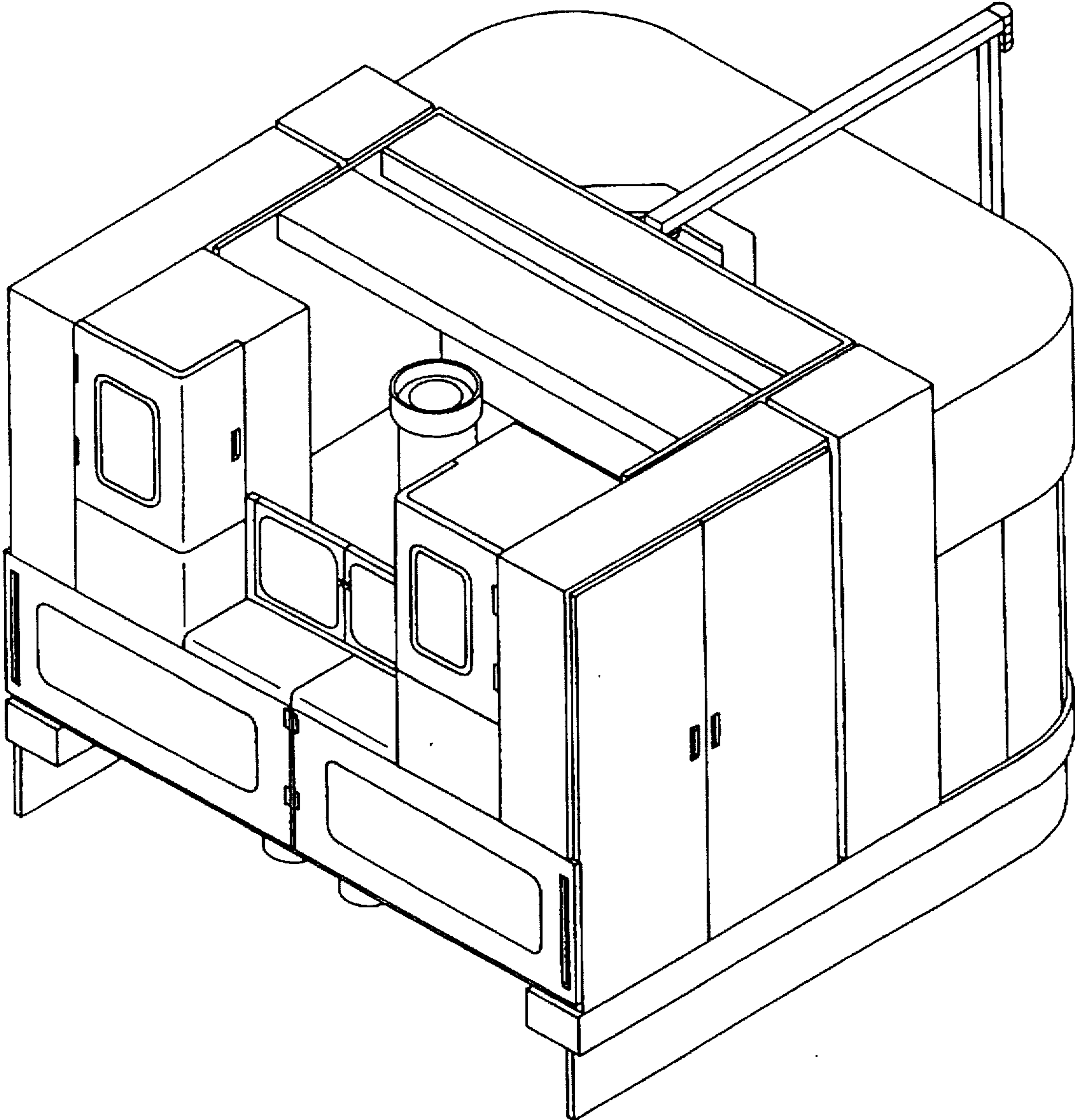

Fig. 79

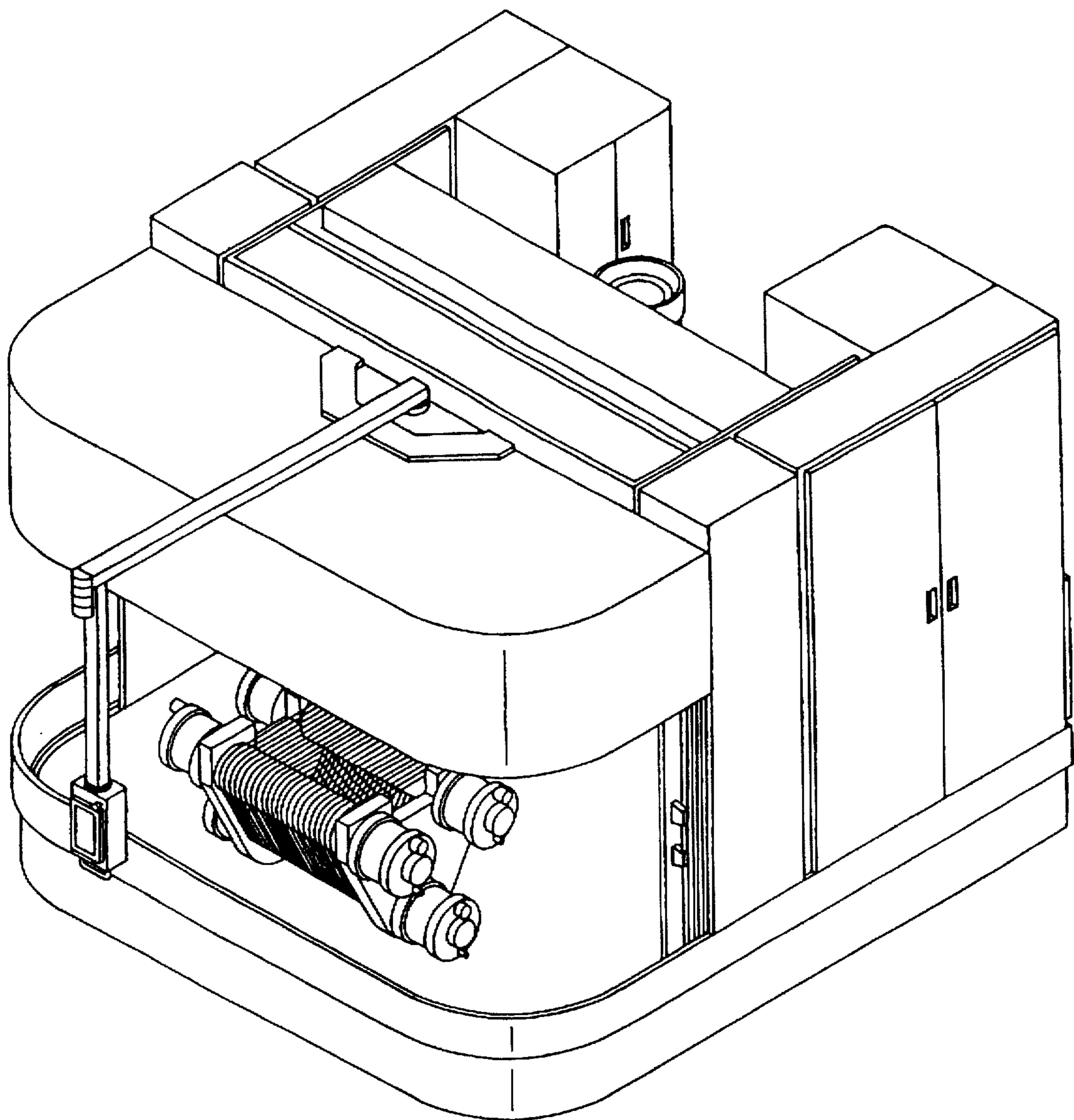

Fig. 80

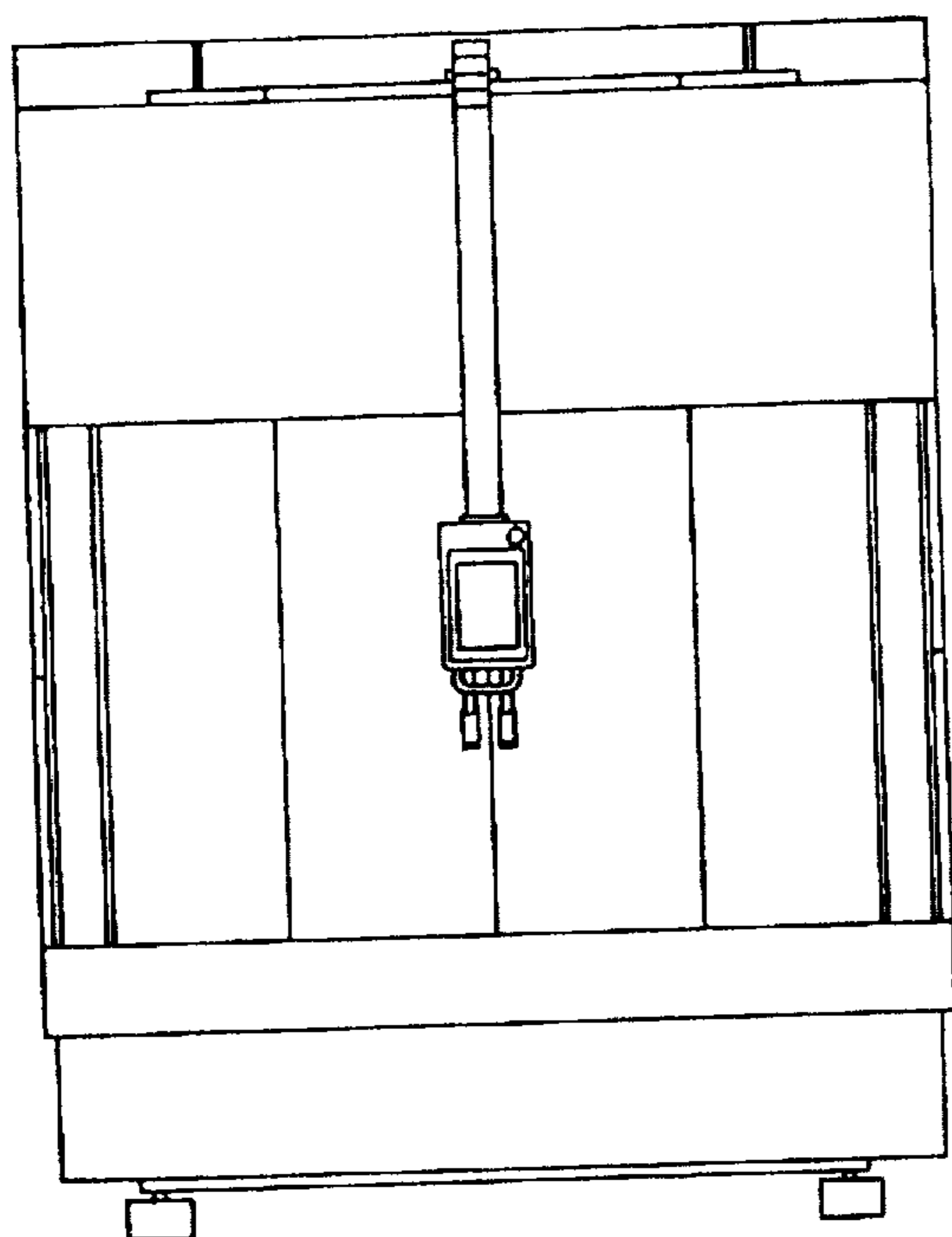

Fig. 81

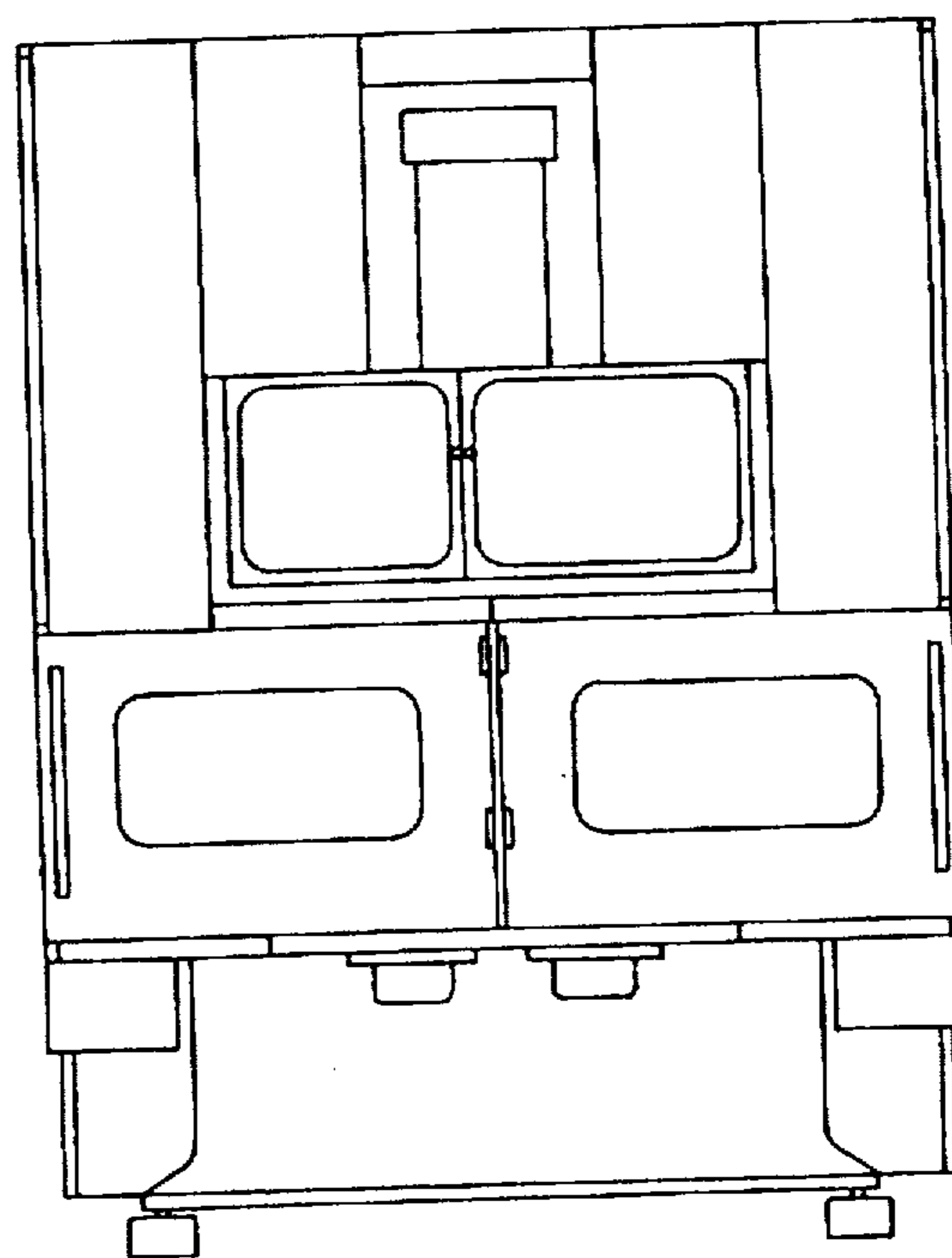

Fig. 82

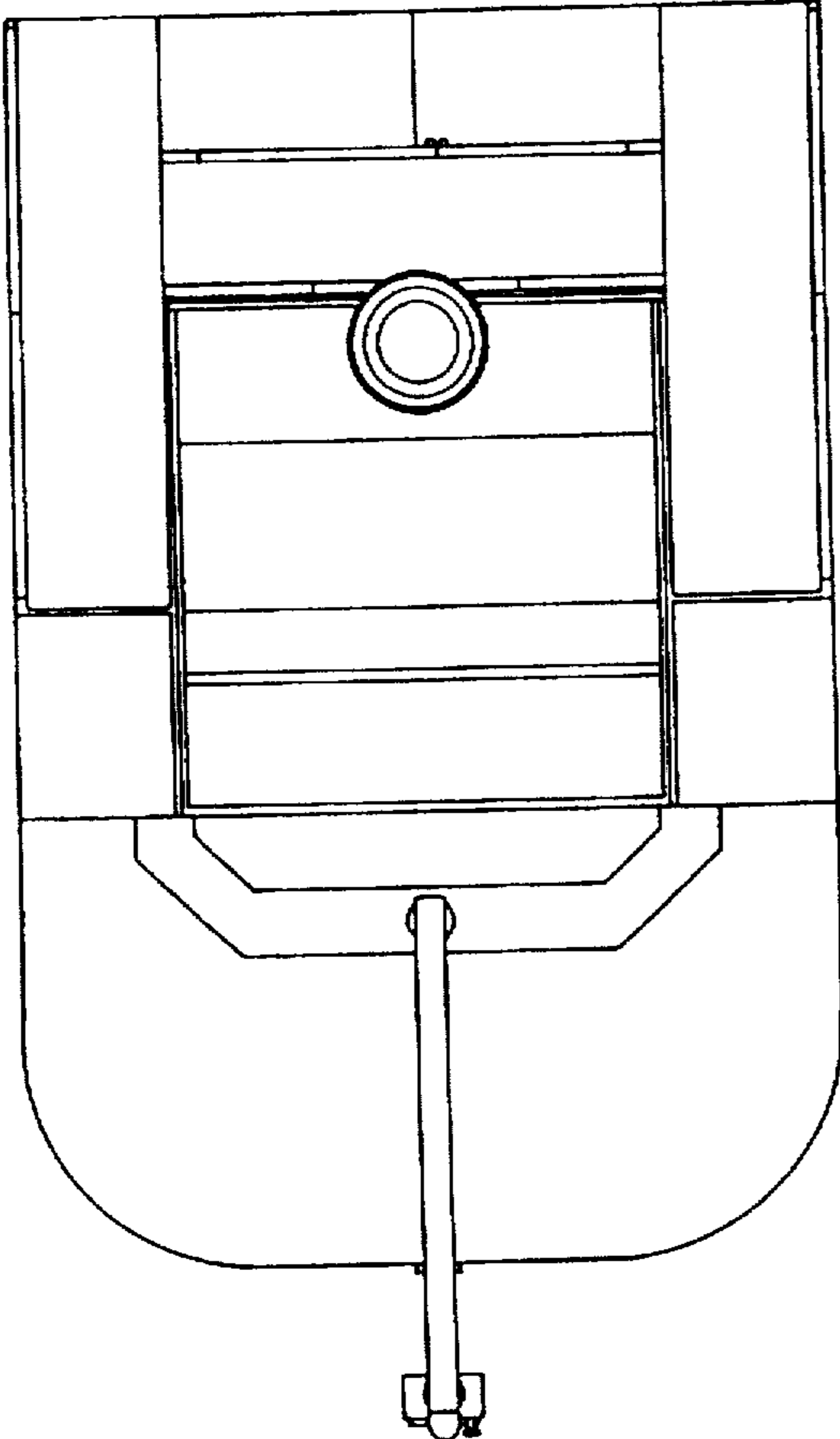

Fig. 83

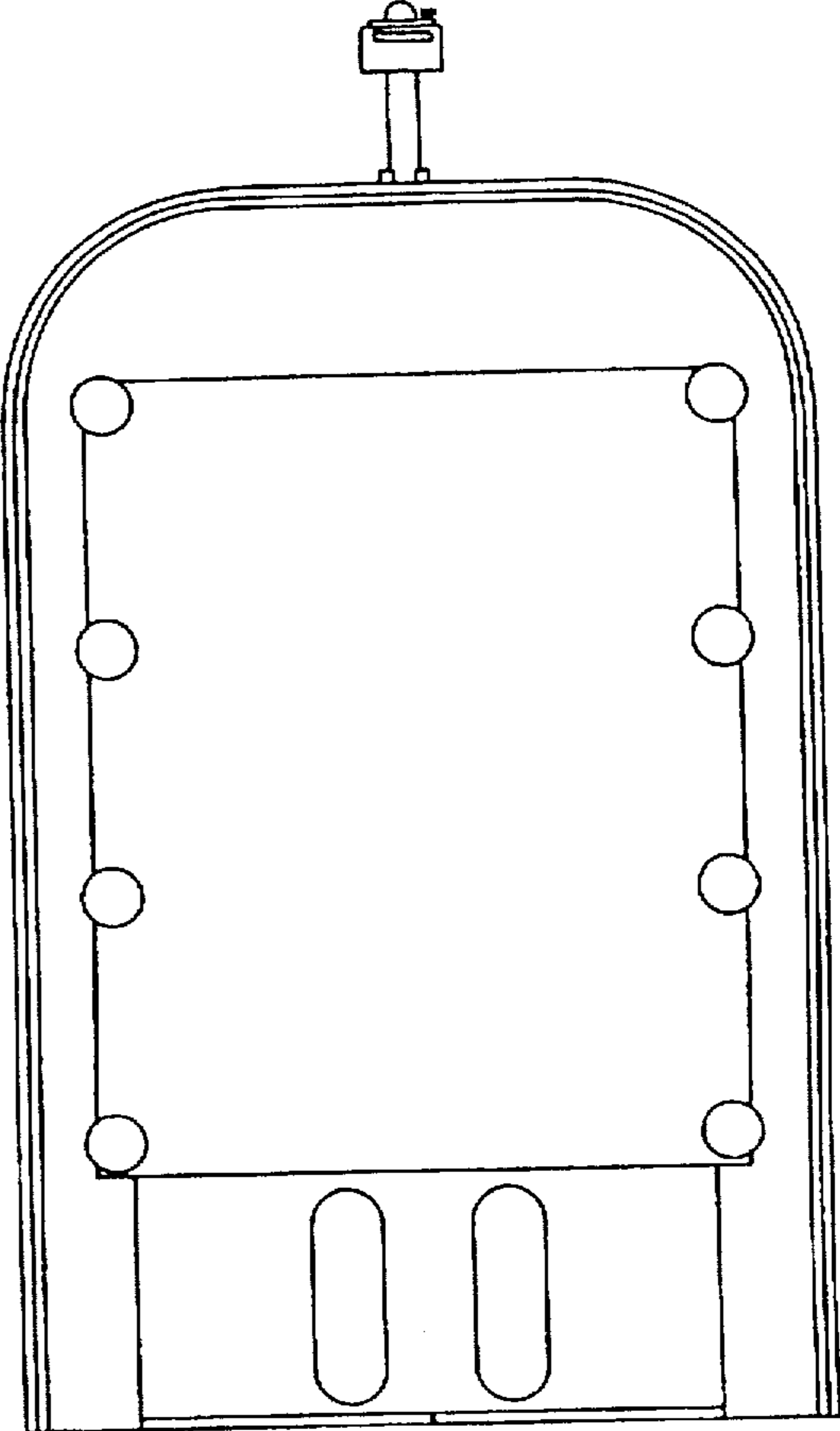

Fig. 84

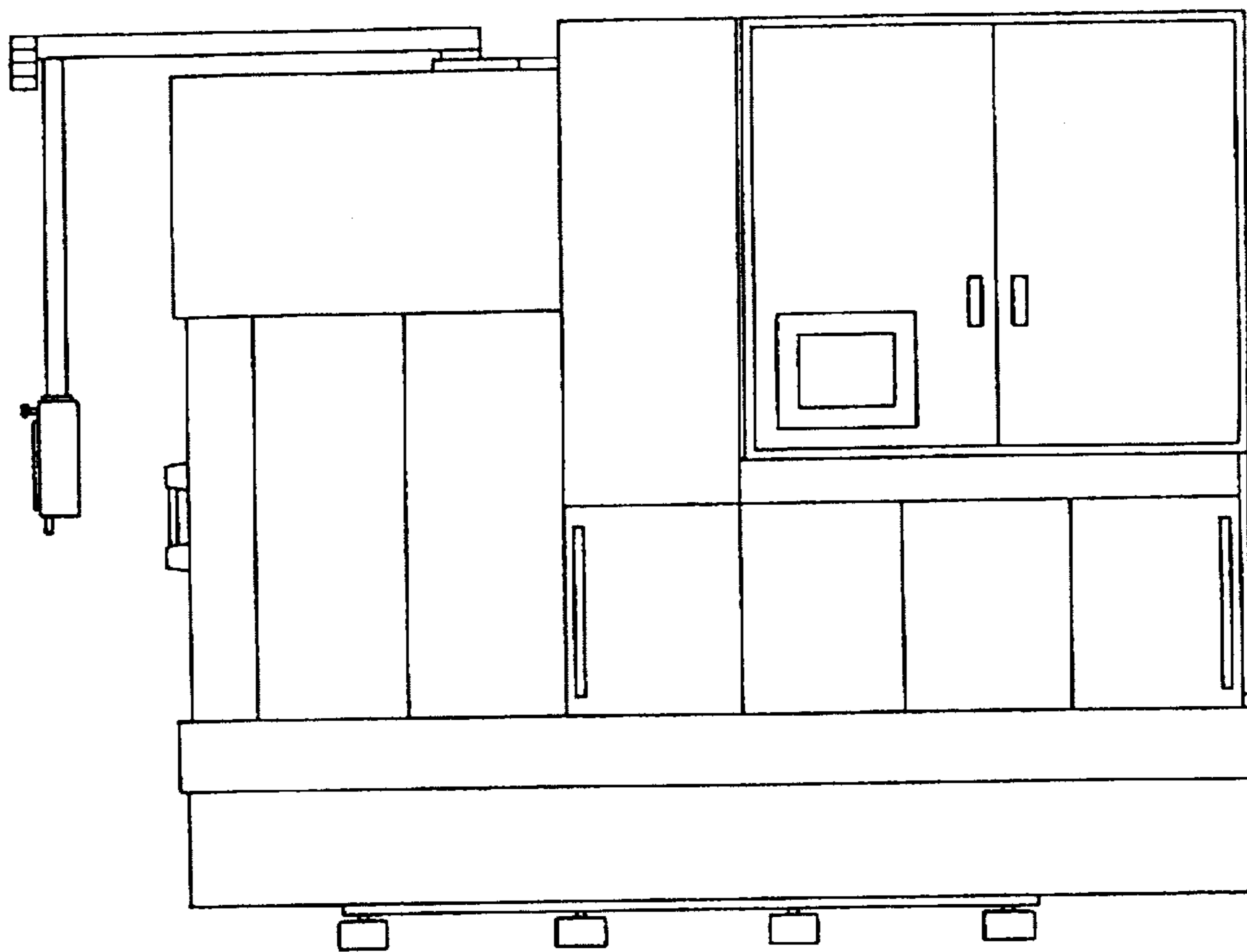

Fig. 85

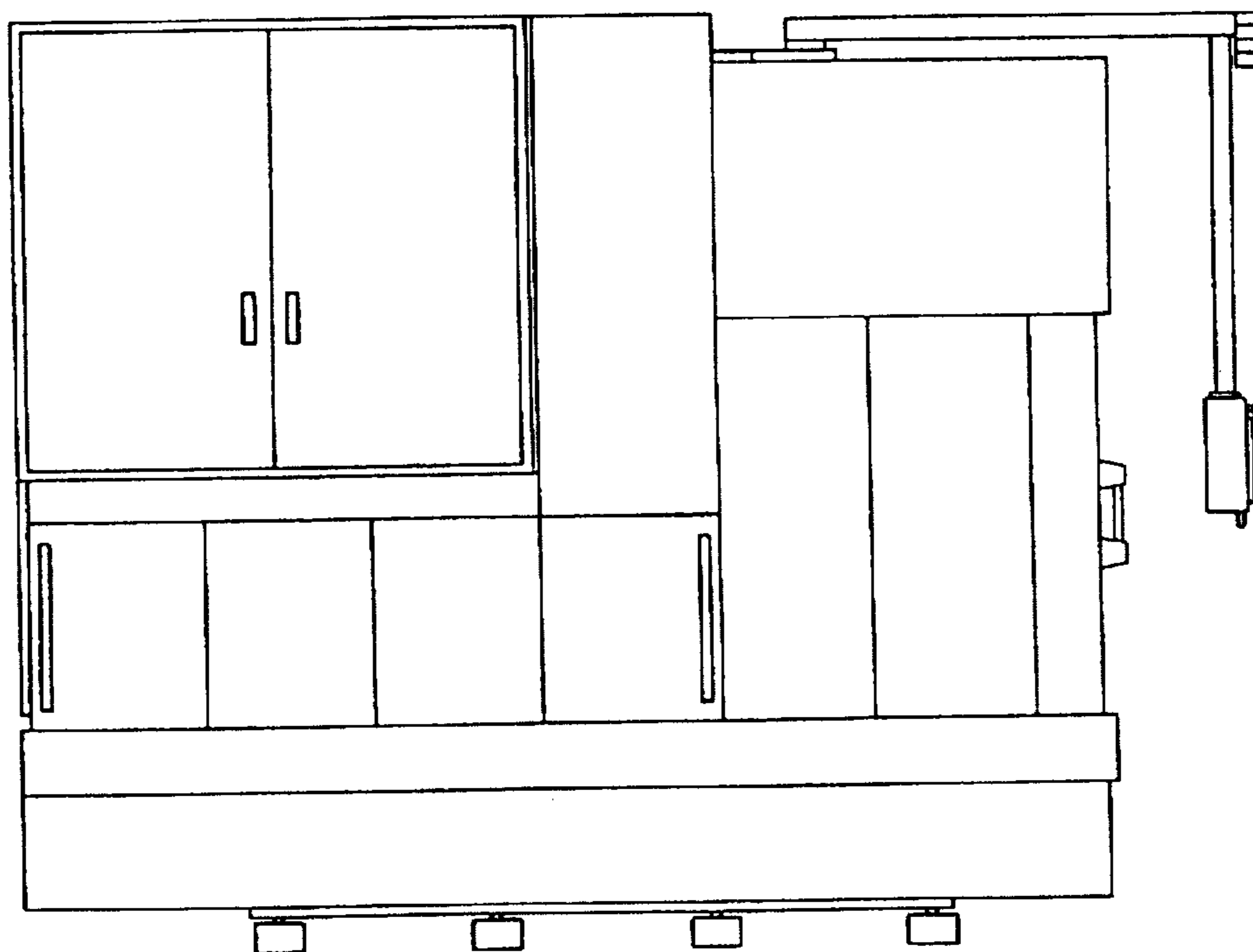

Fig. 86

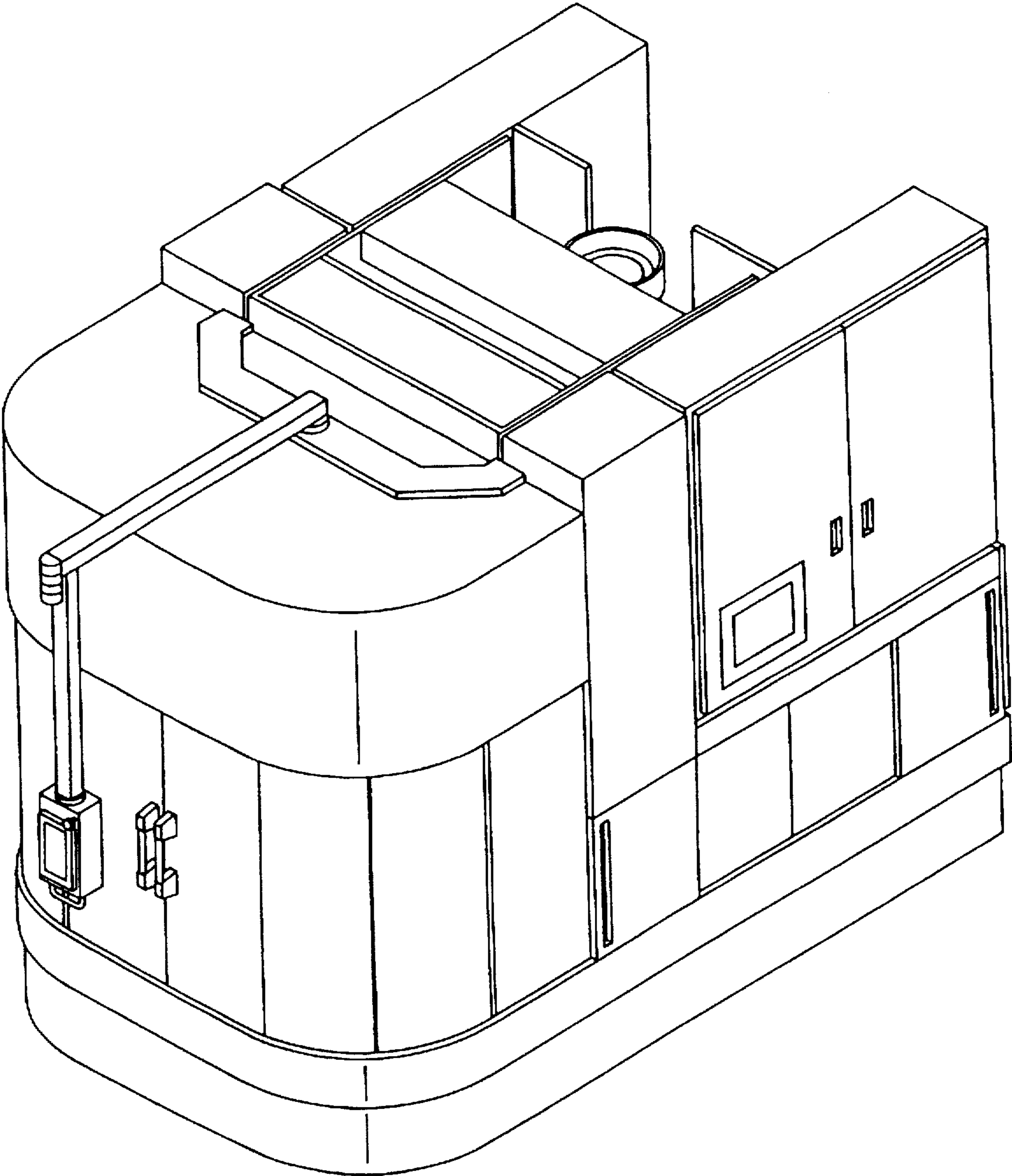

Fig. 87

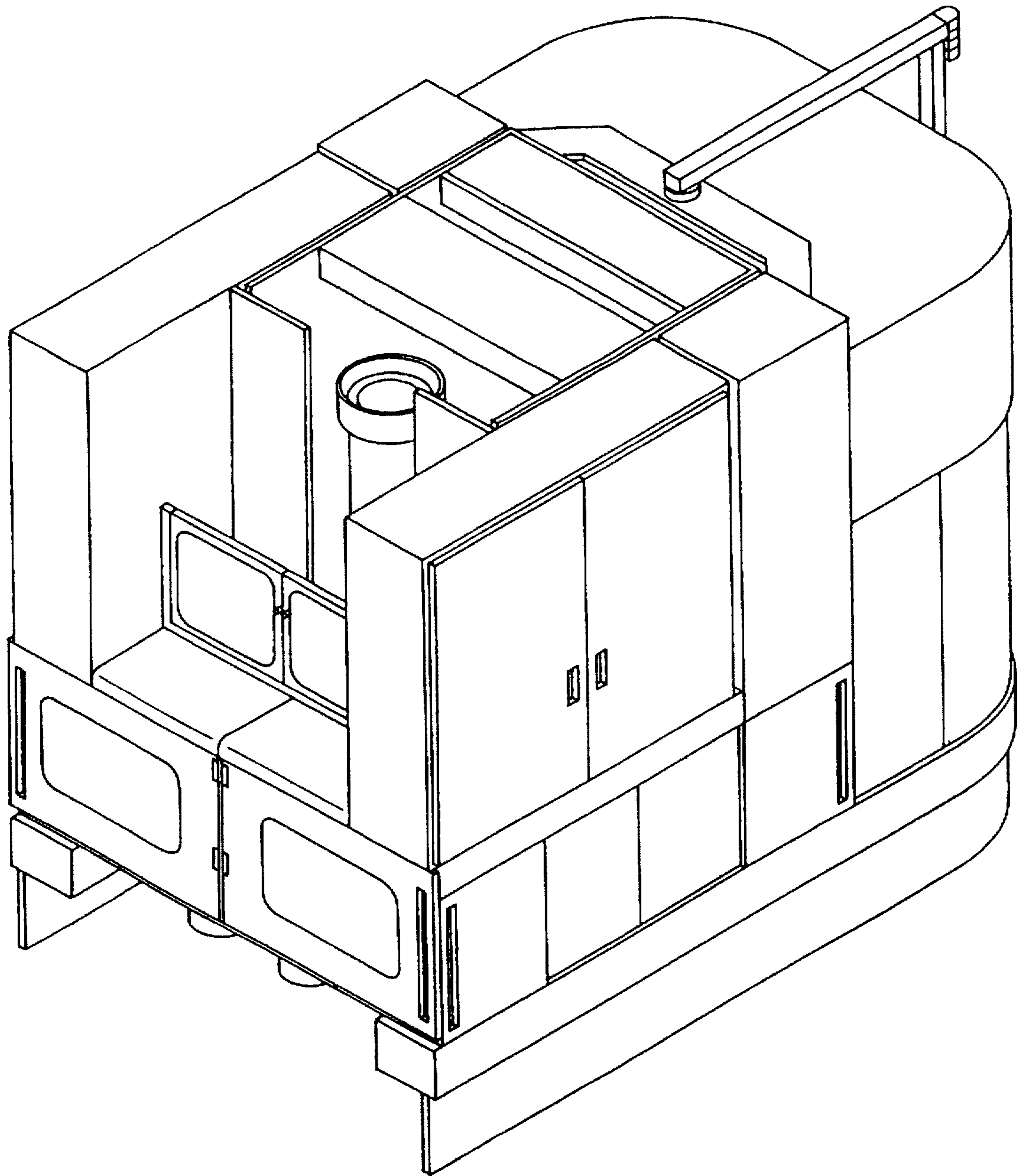

Fig. 88

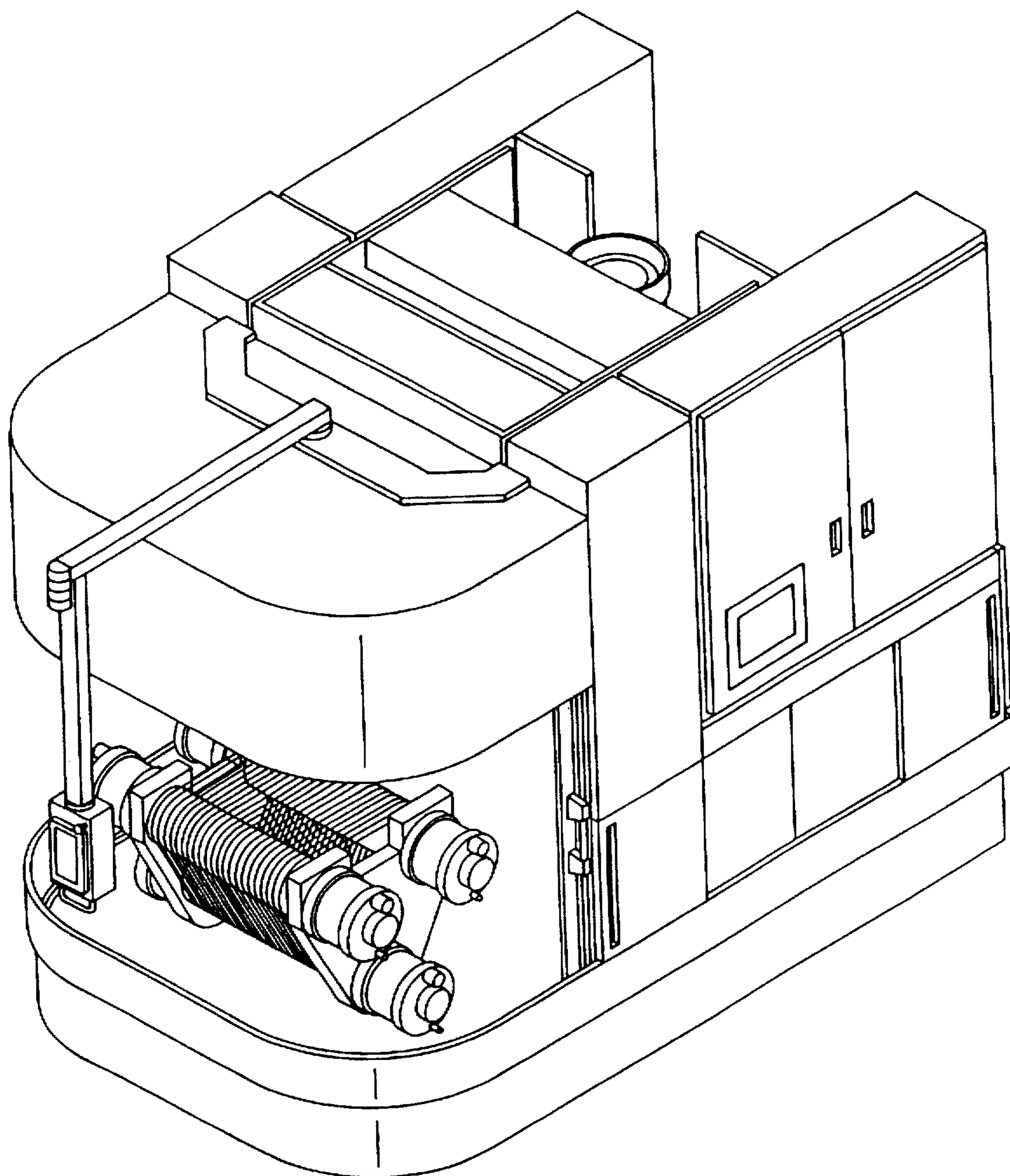

Fig. 89

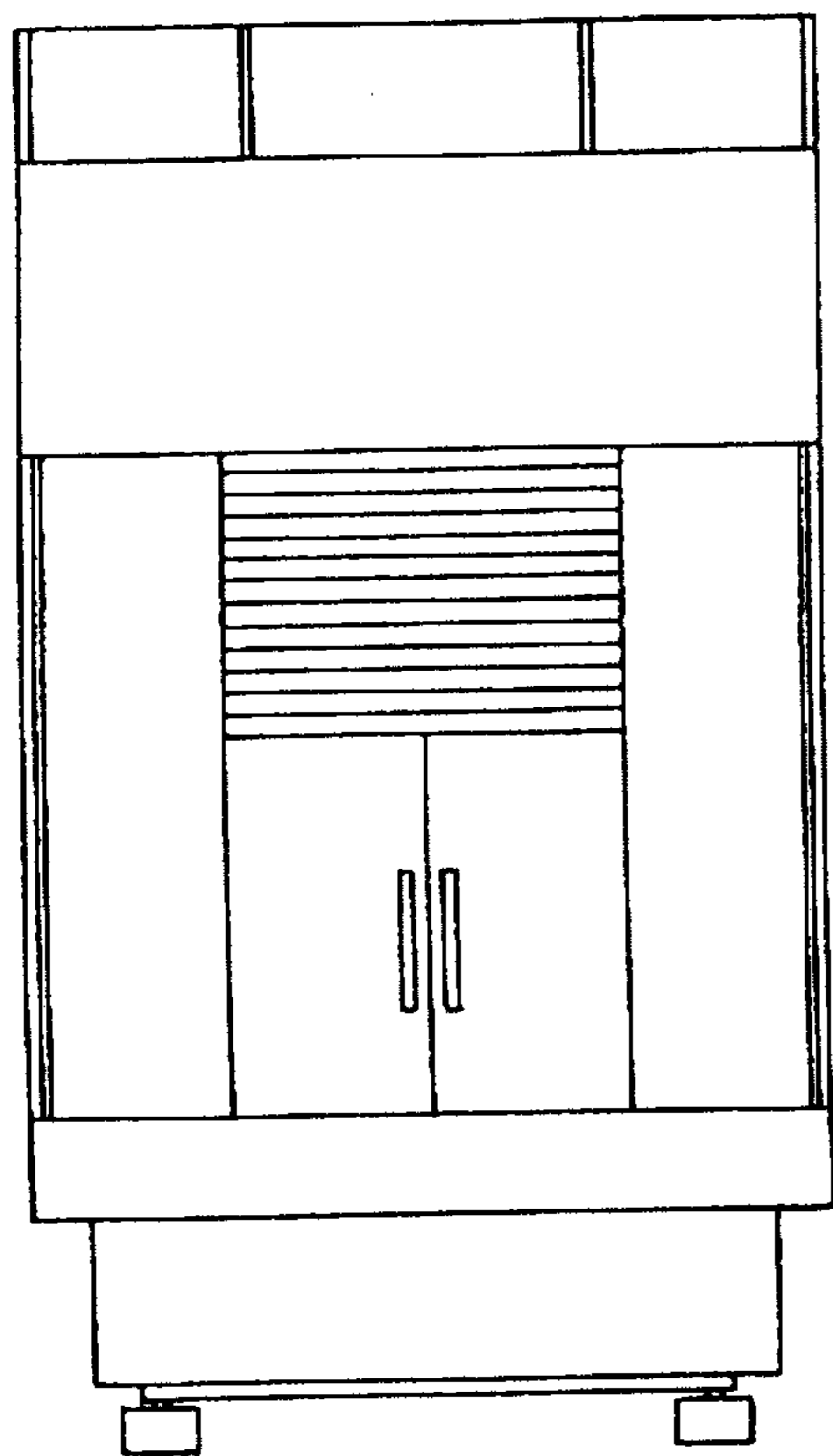

Fig. 90

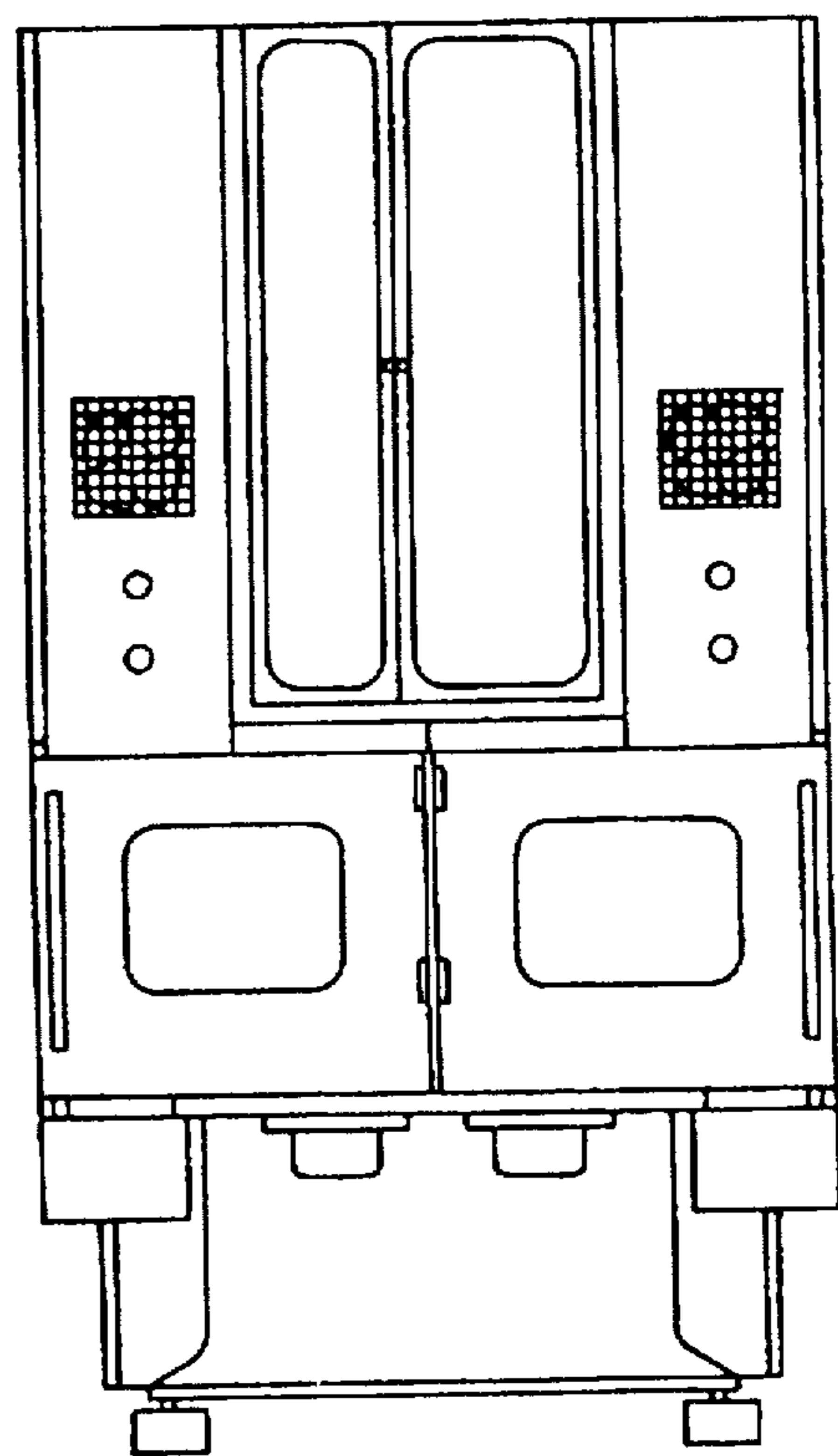

Fig. 91

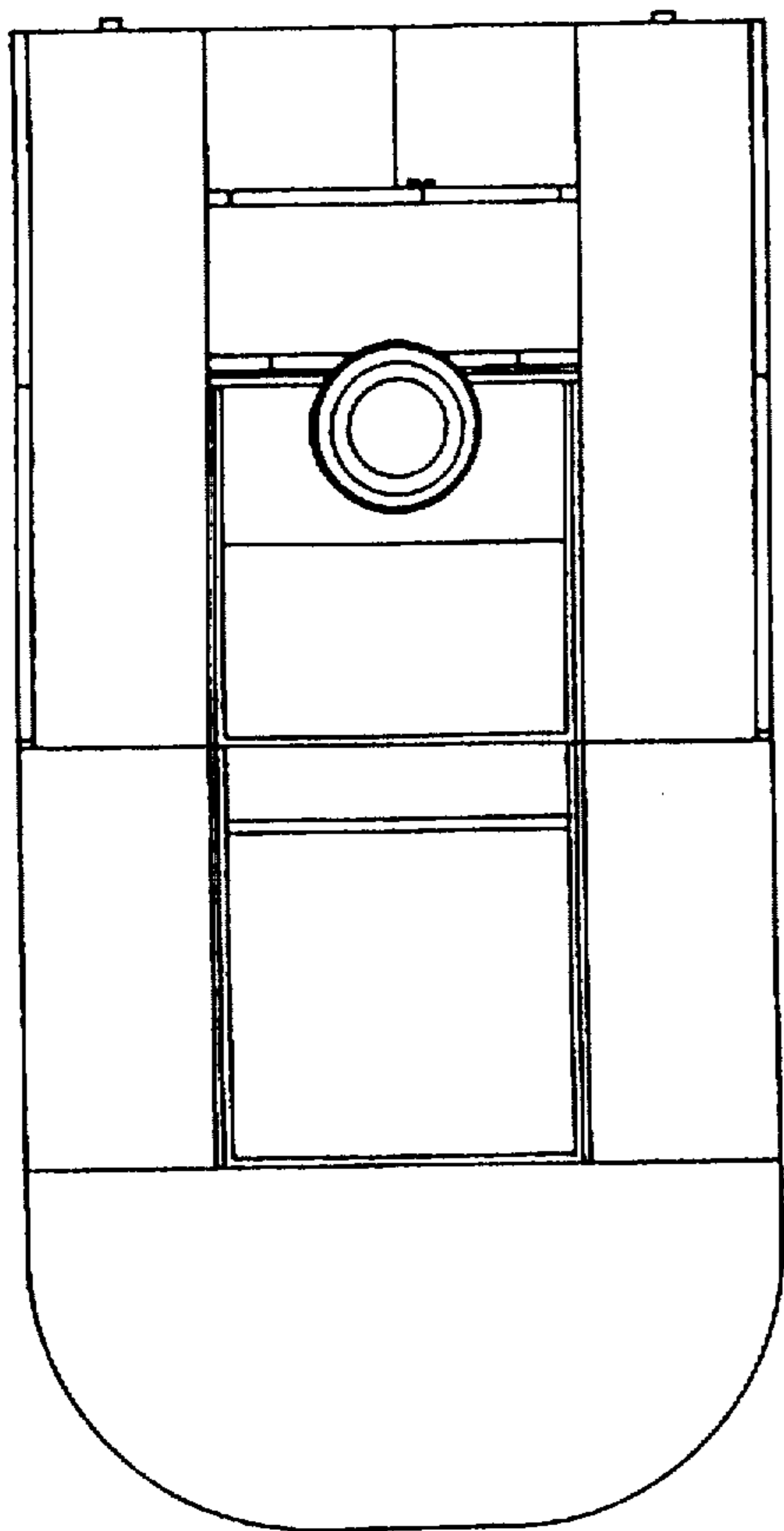

Fig. 92

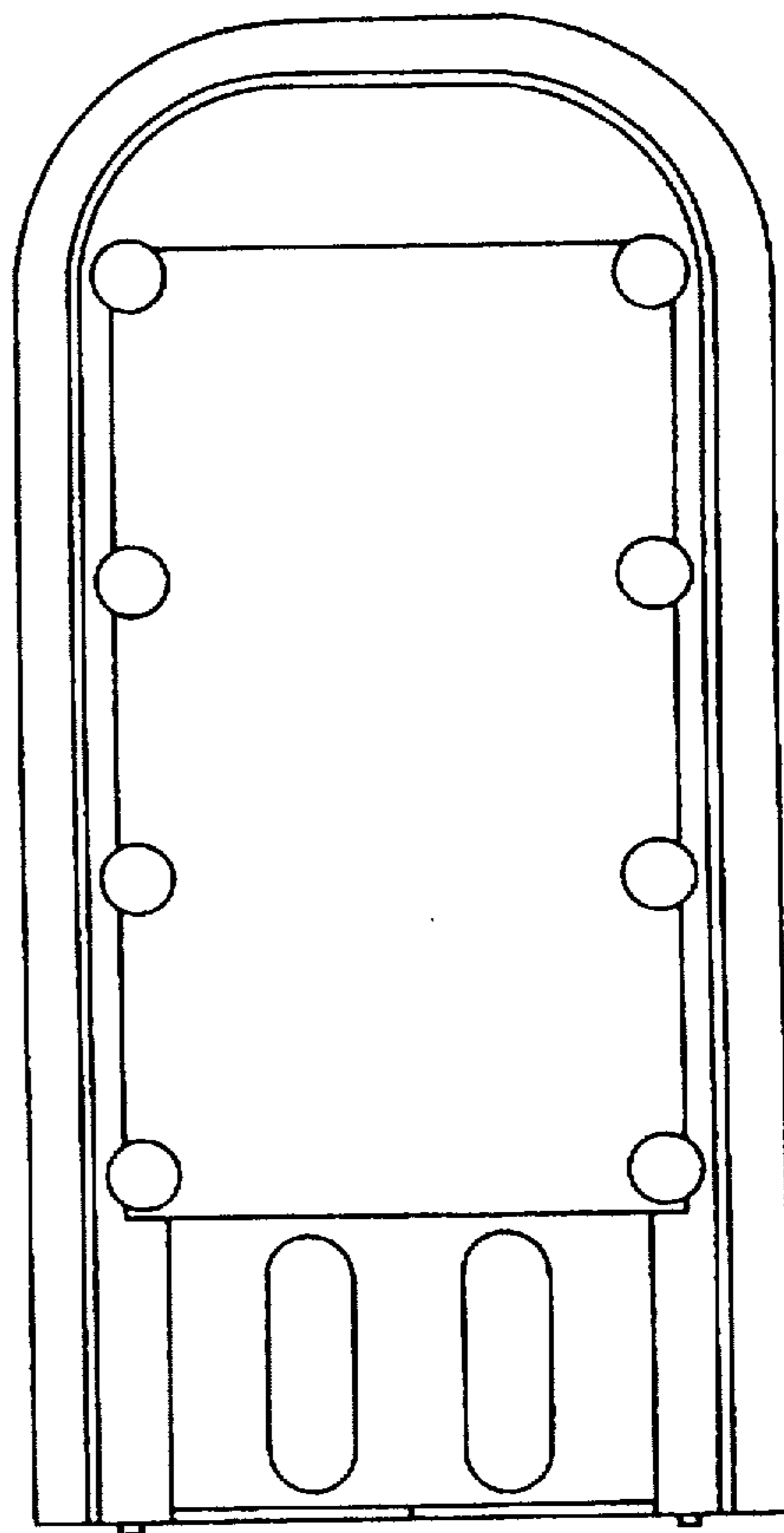

Fig. 93

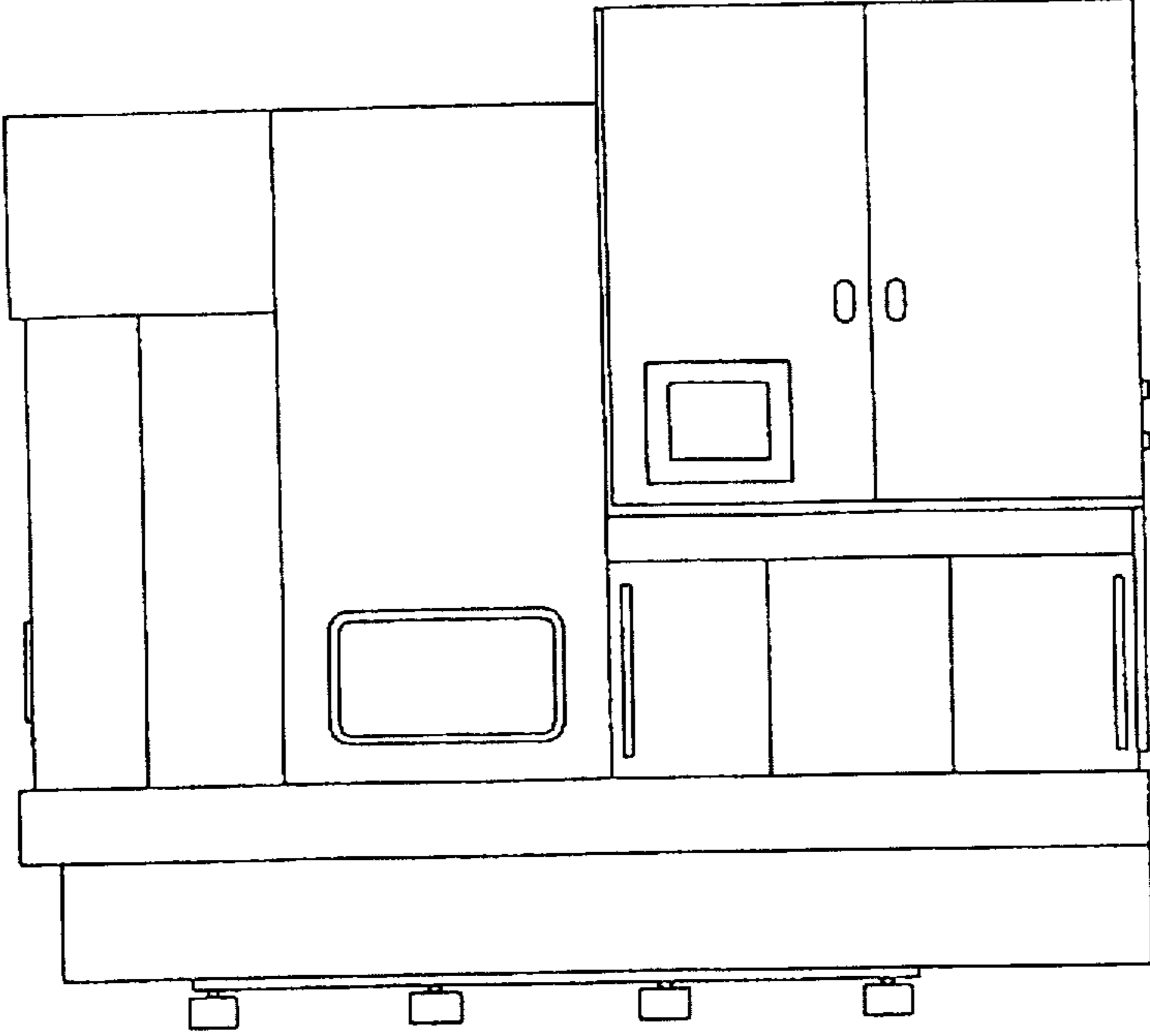

Fig. 94

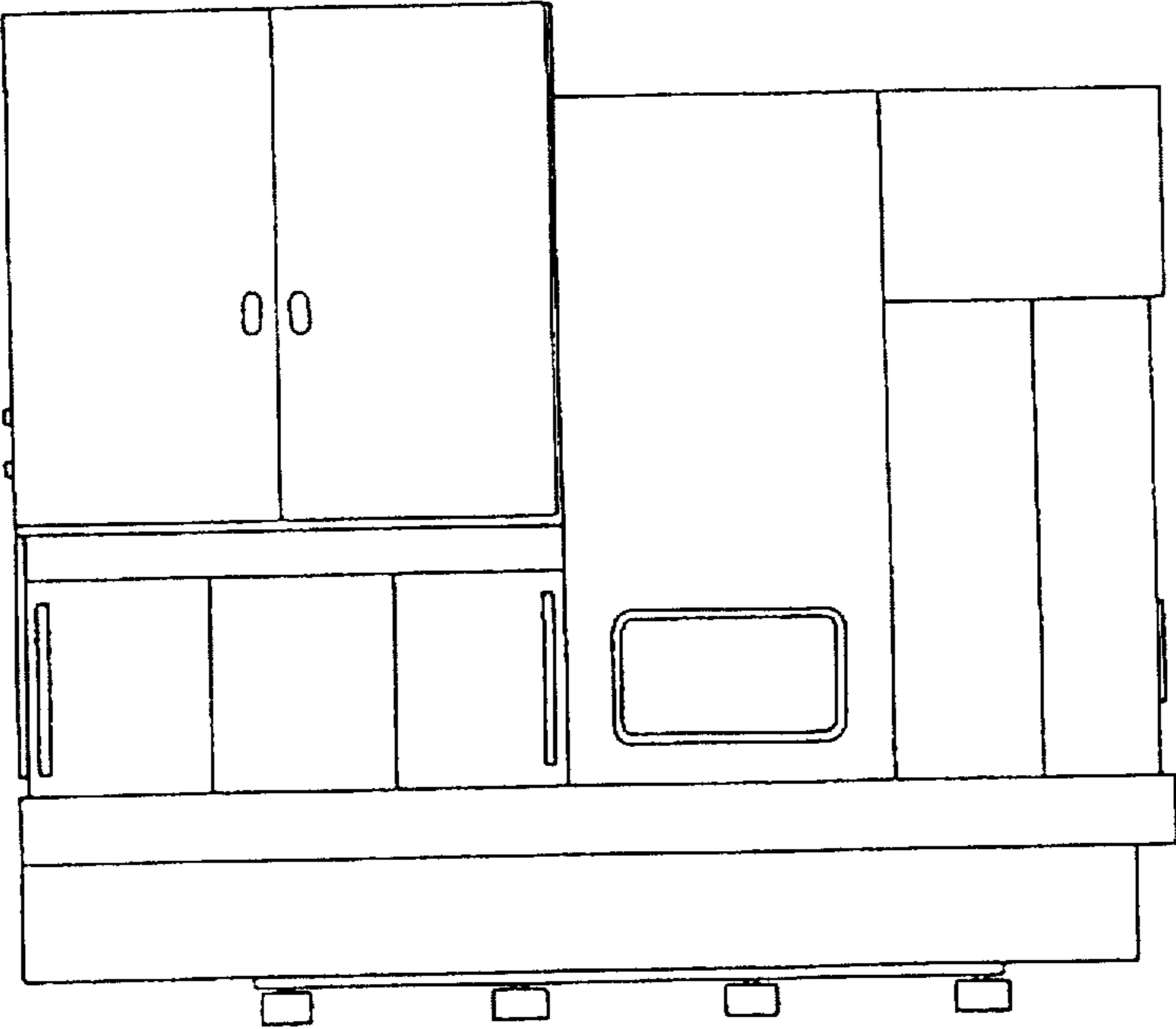

Fig. 95

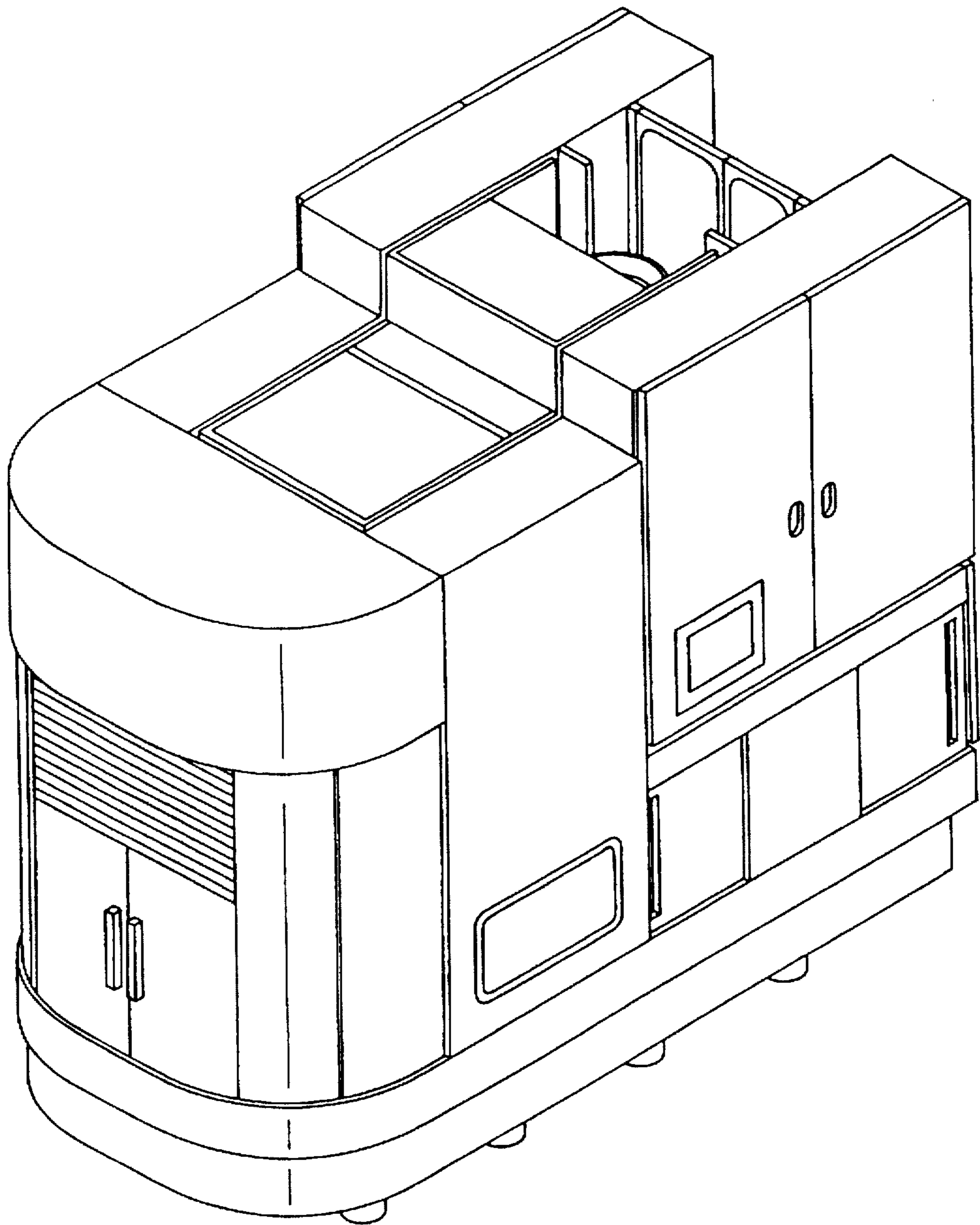

Fig. 96

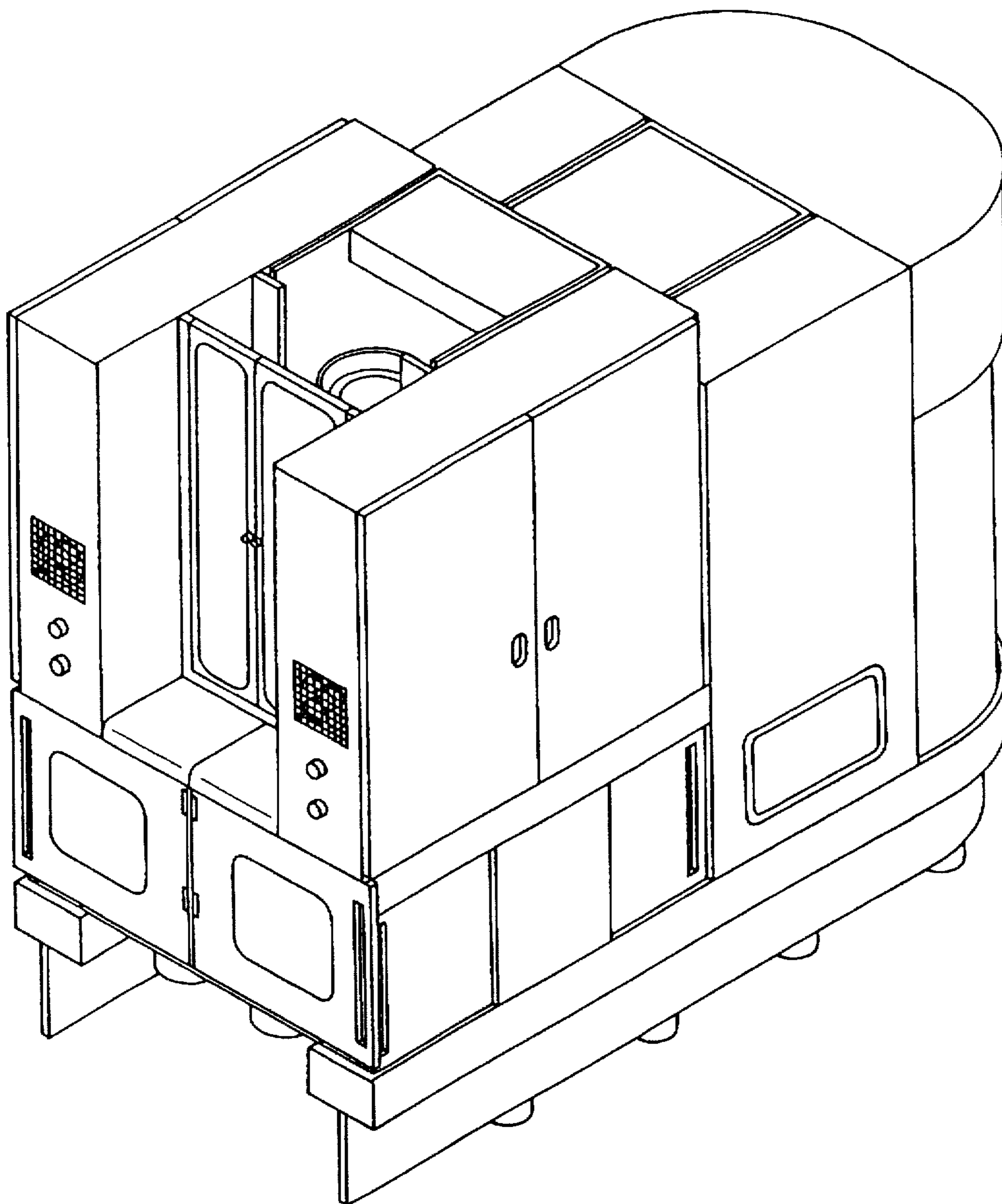

Fig. 97

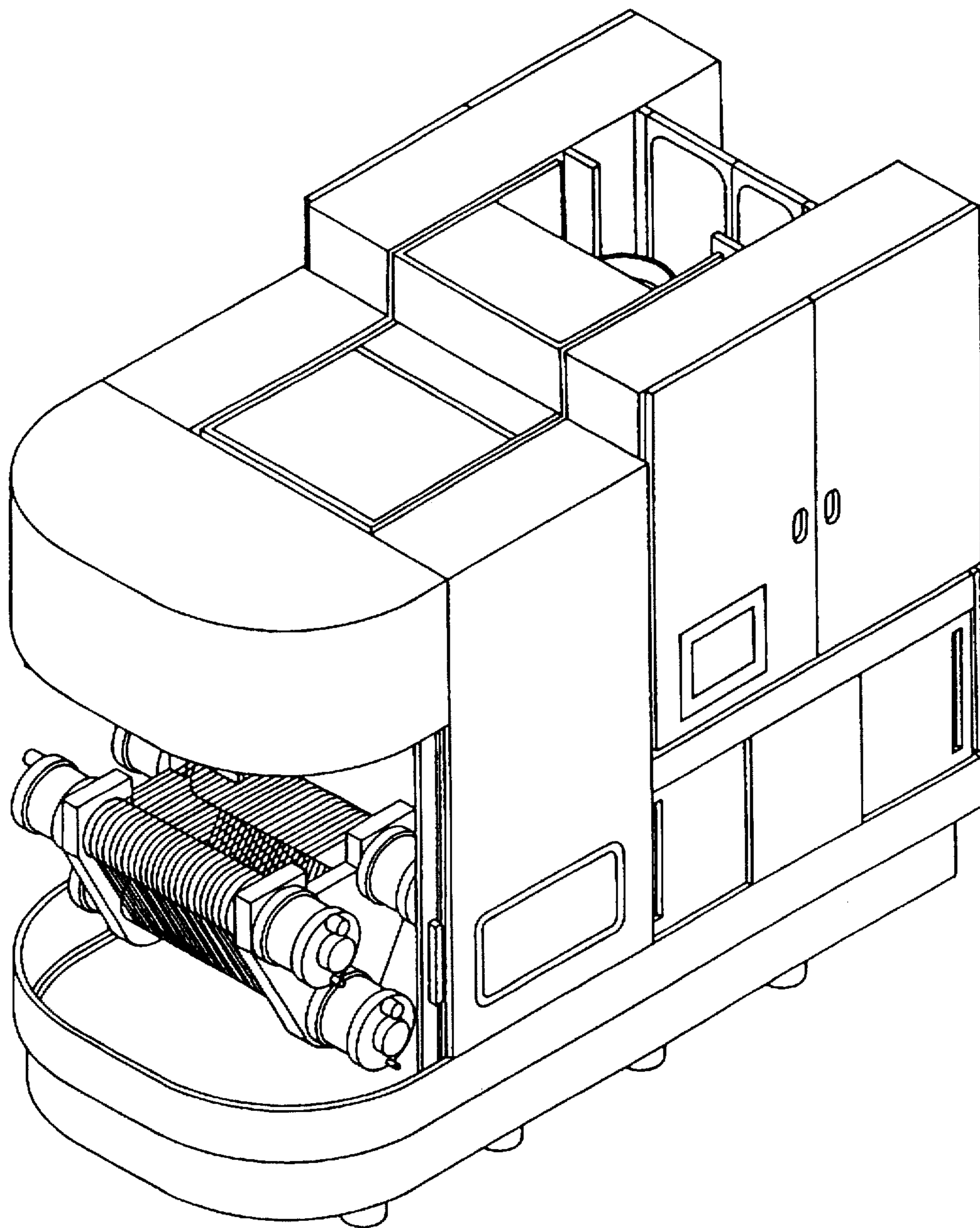

Fig. 98

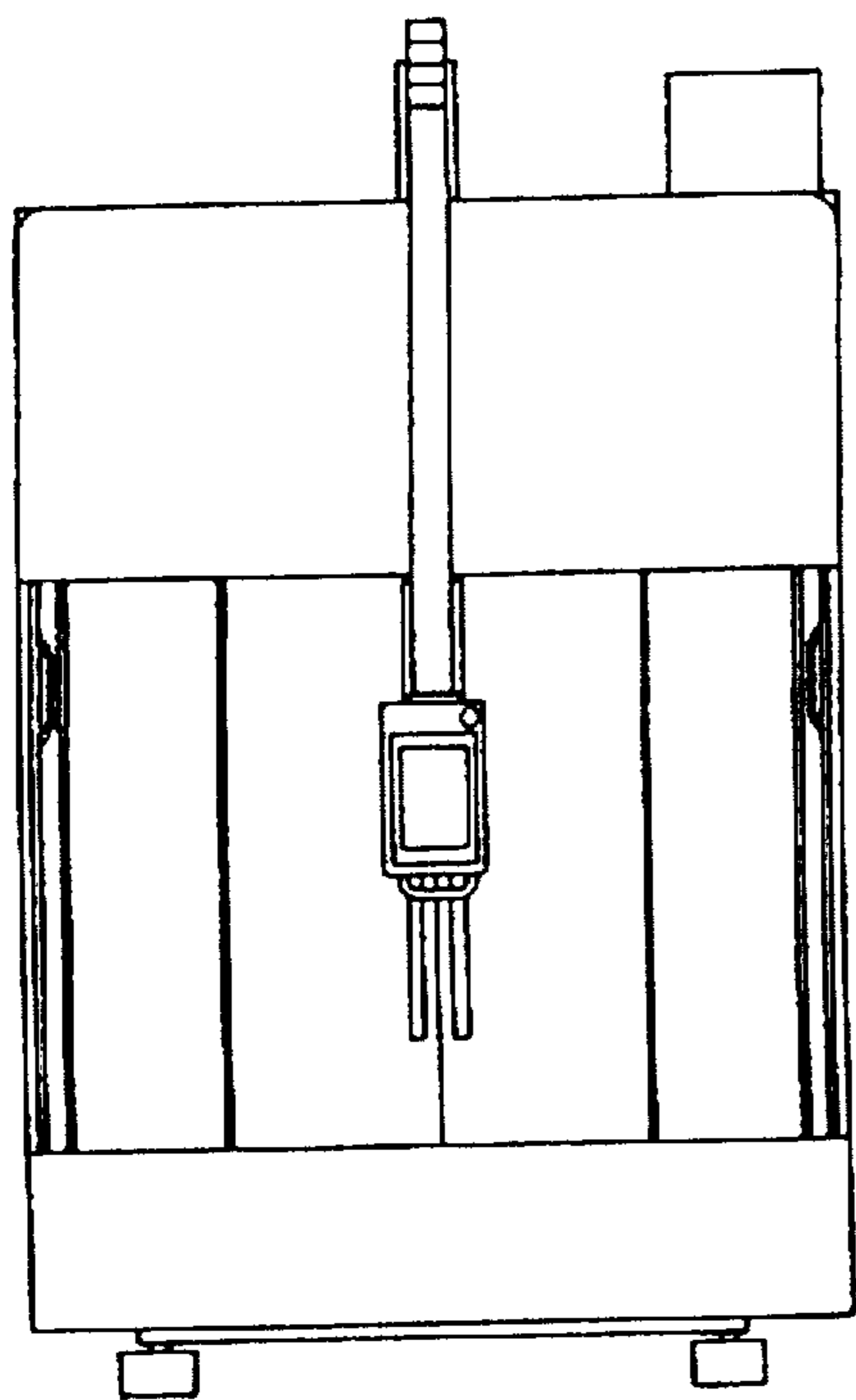

Fig. 99

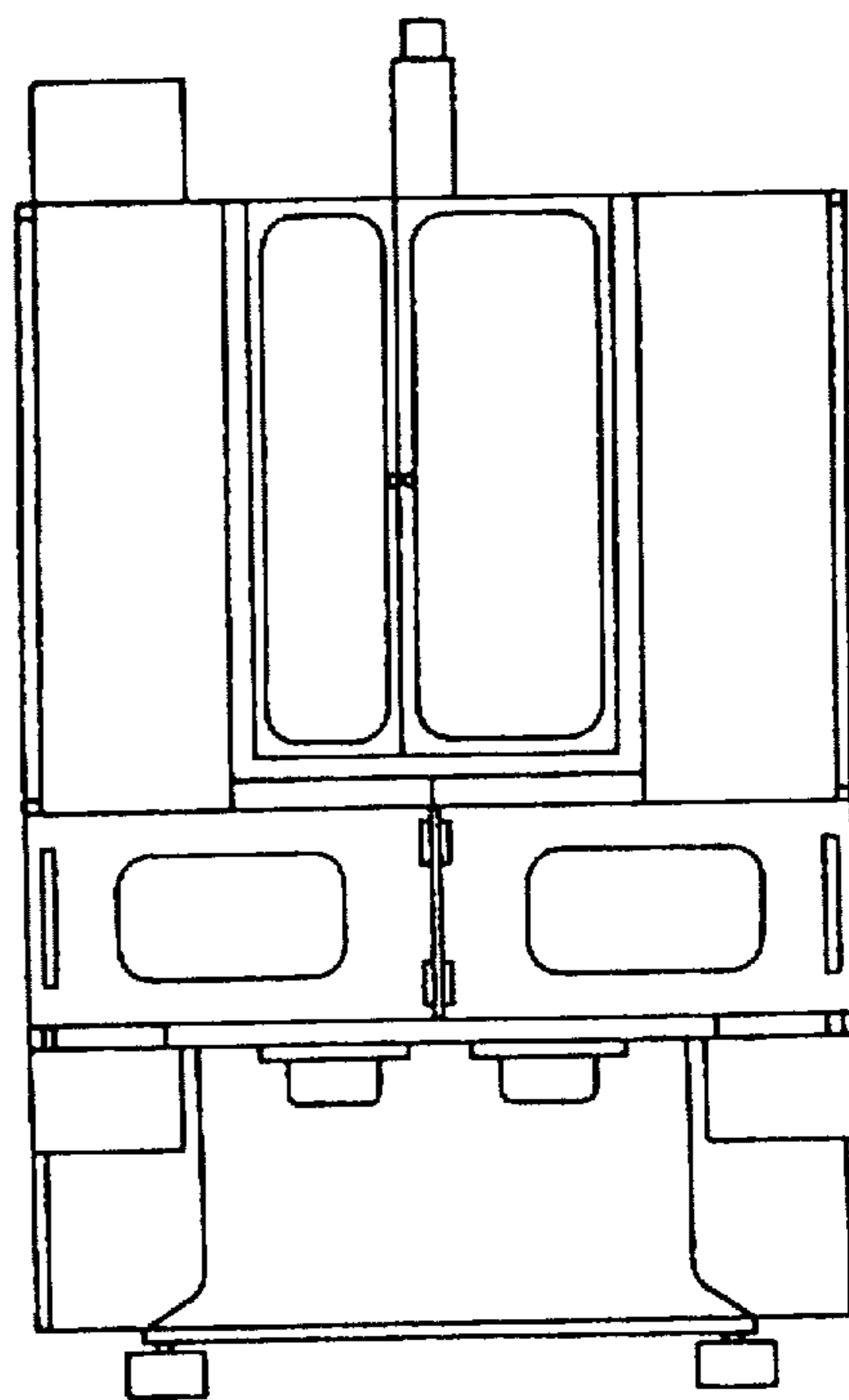

Fig. 100

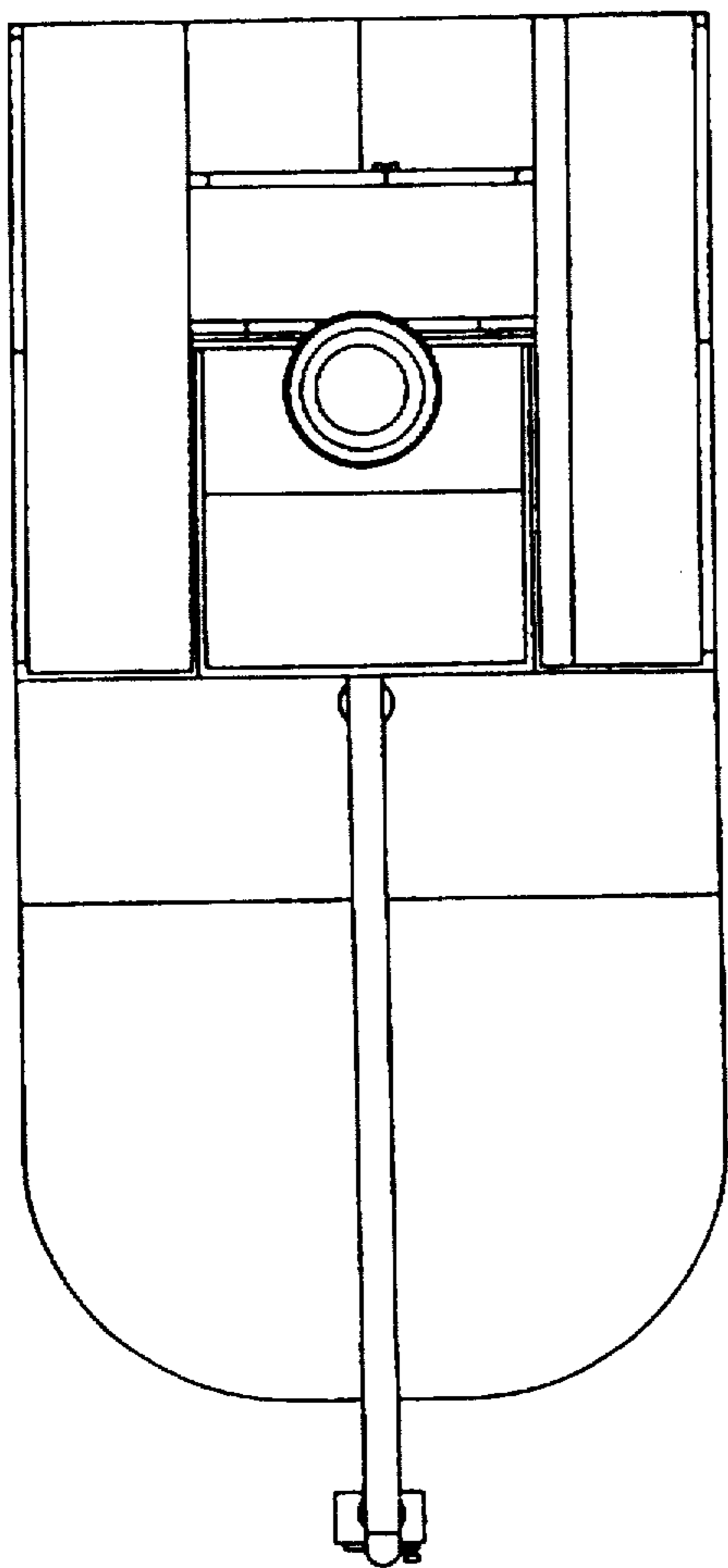

Fig. 101

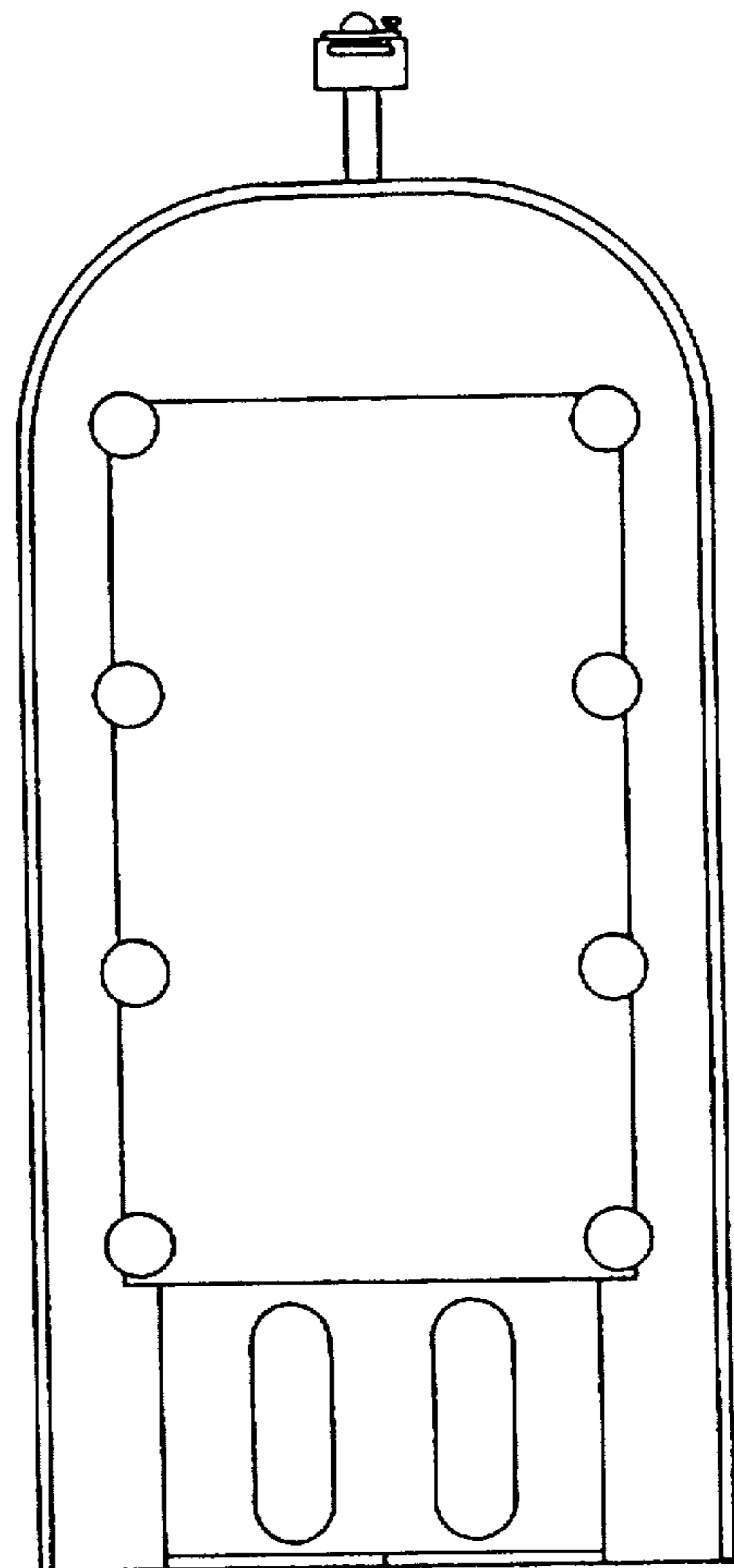

Fig. 102

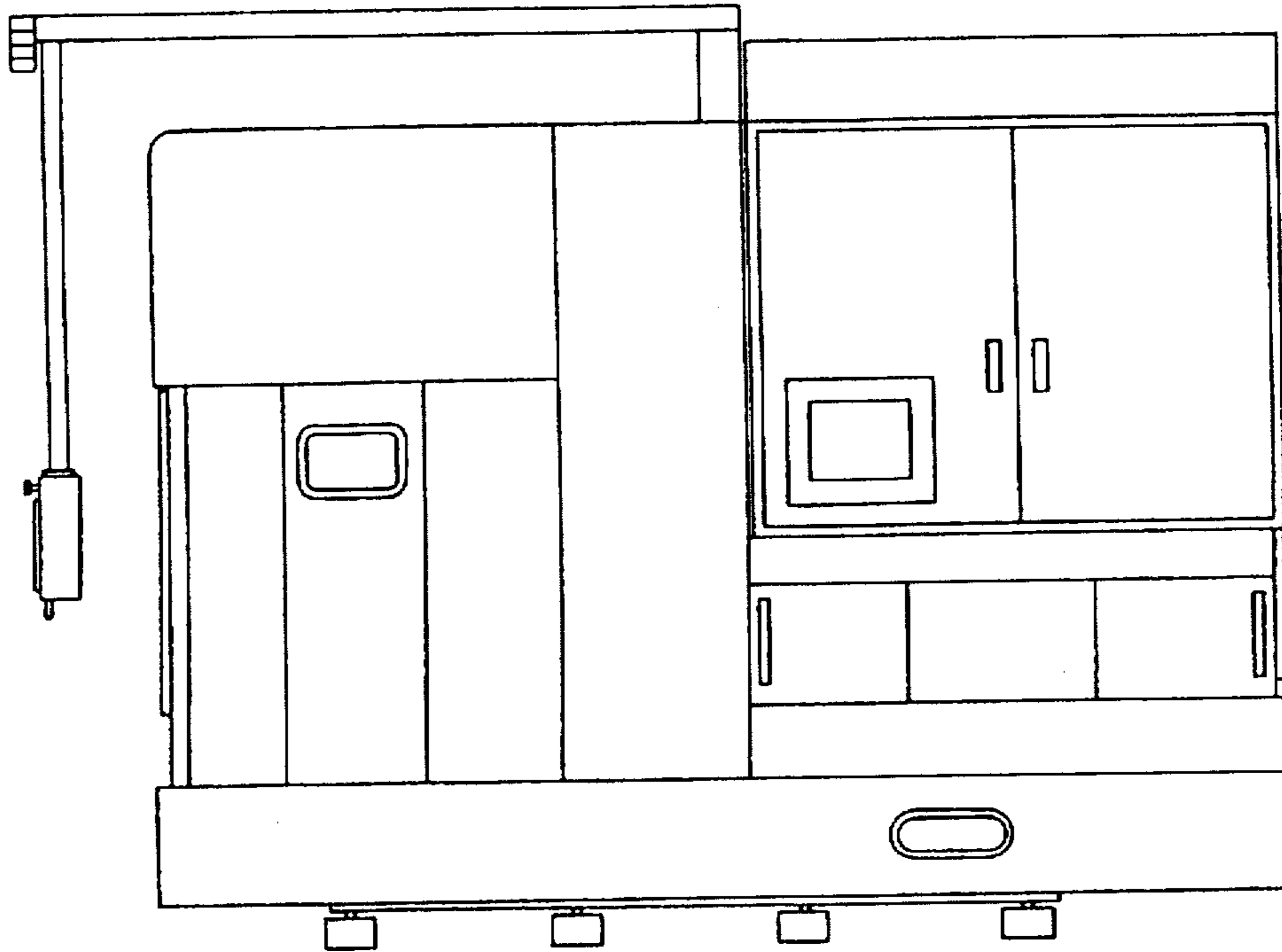

Fig. 103

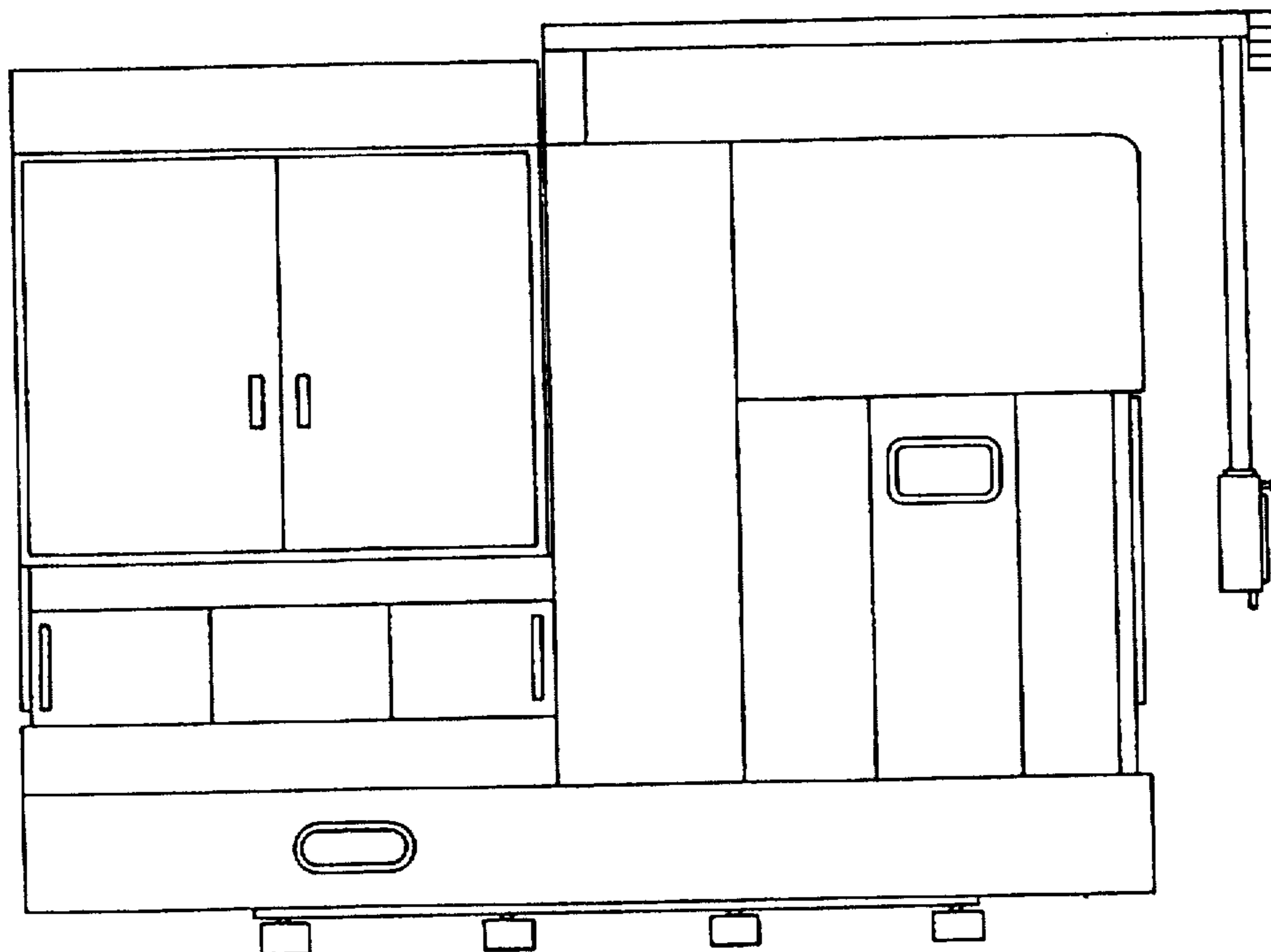

Fig. 104

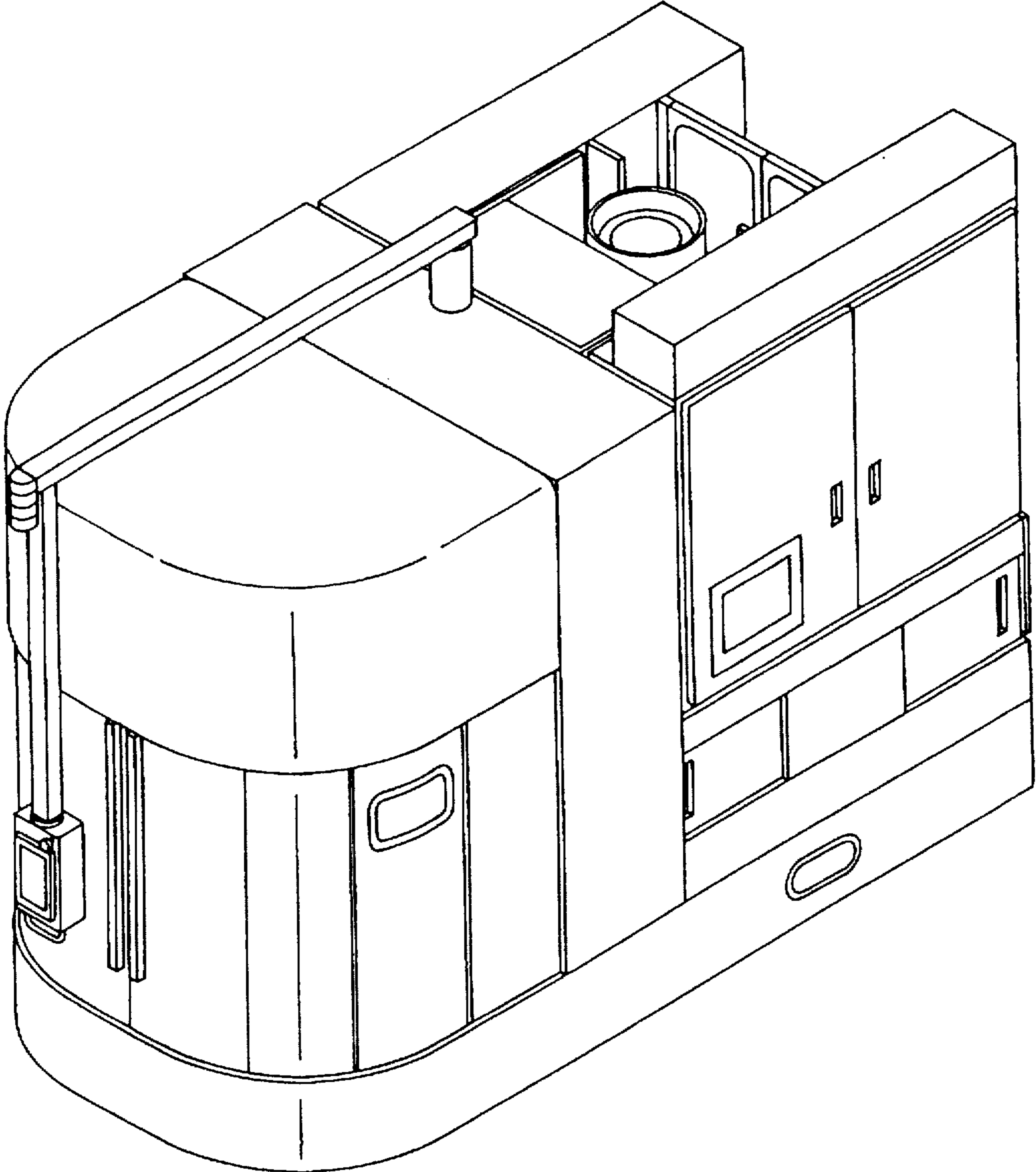

Fig. 105

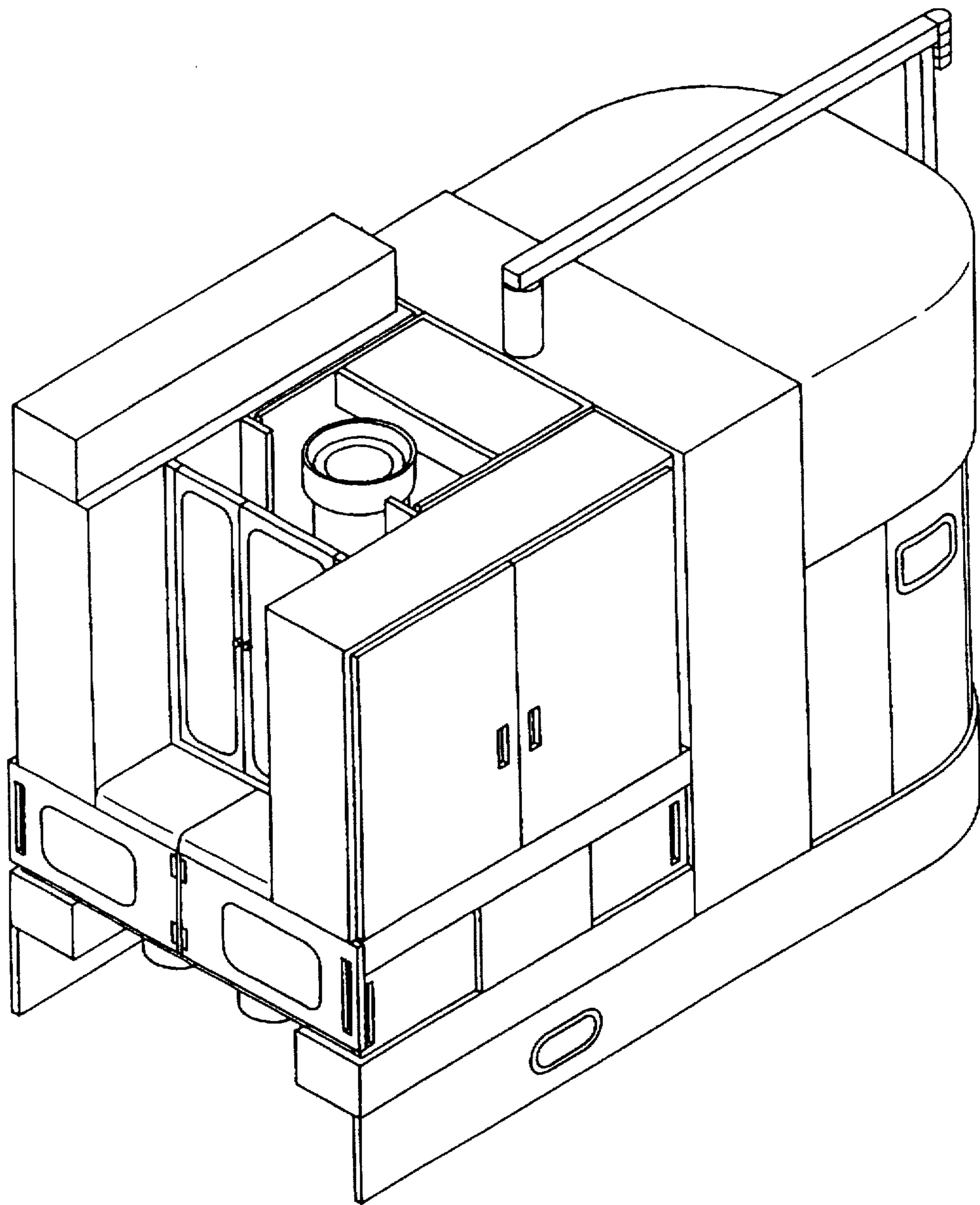

Fig. 106

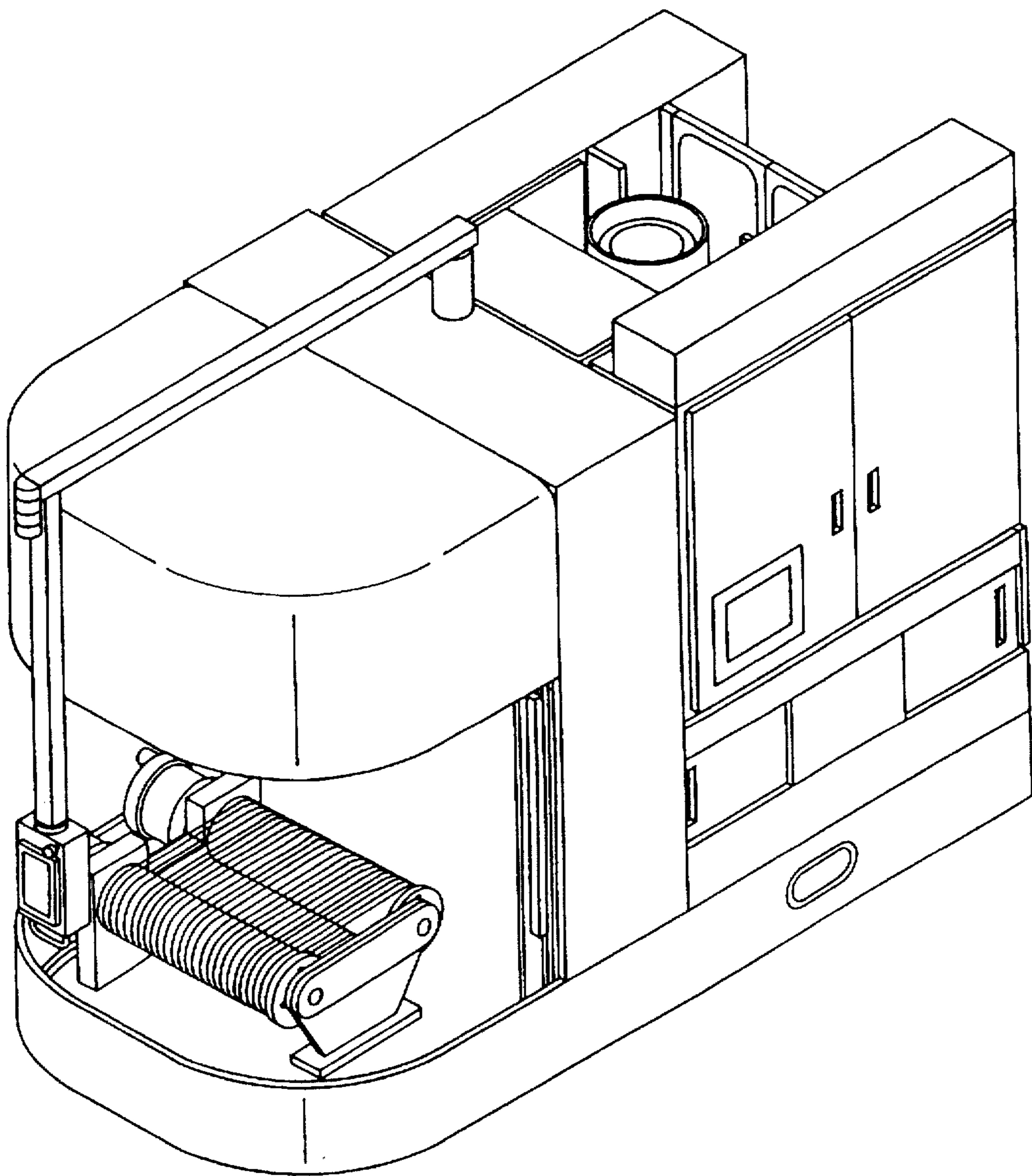

Fig. 107

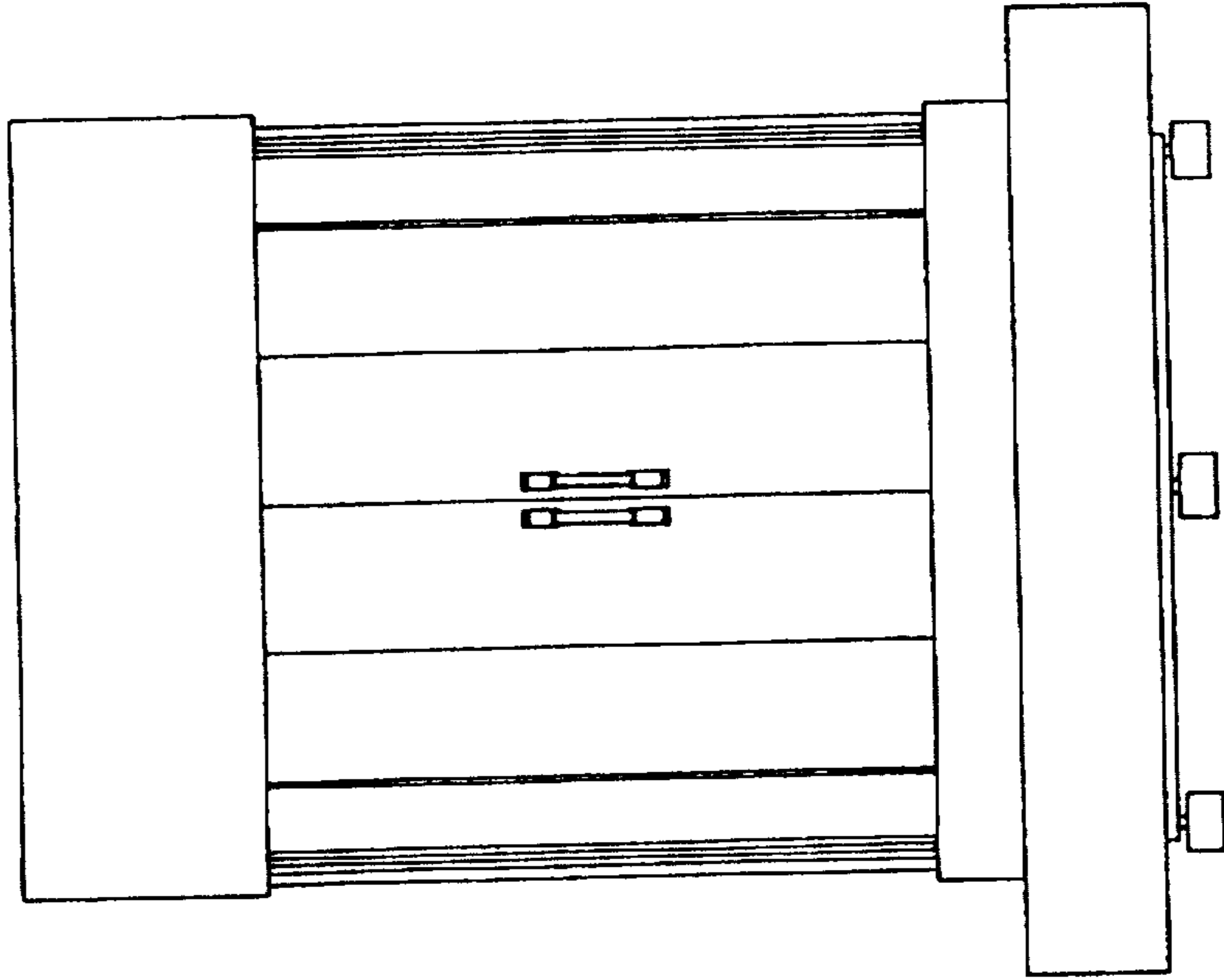

Fig. 108

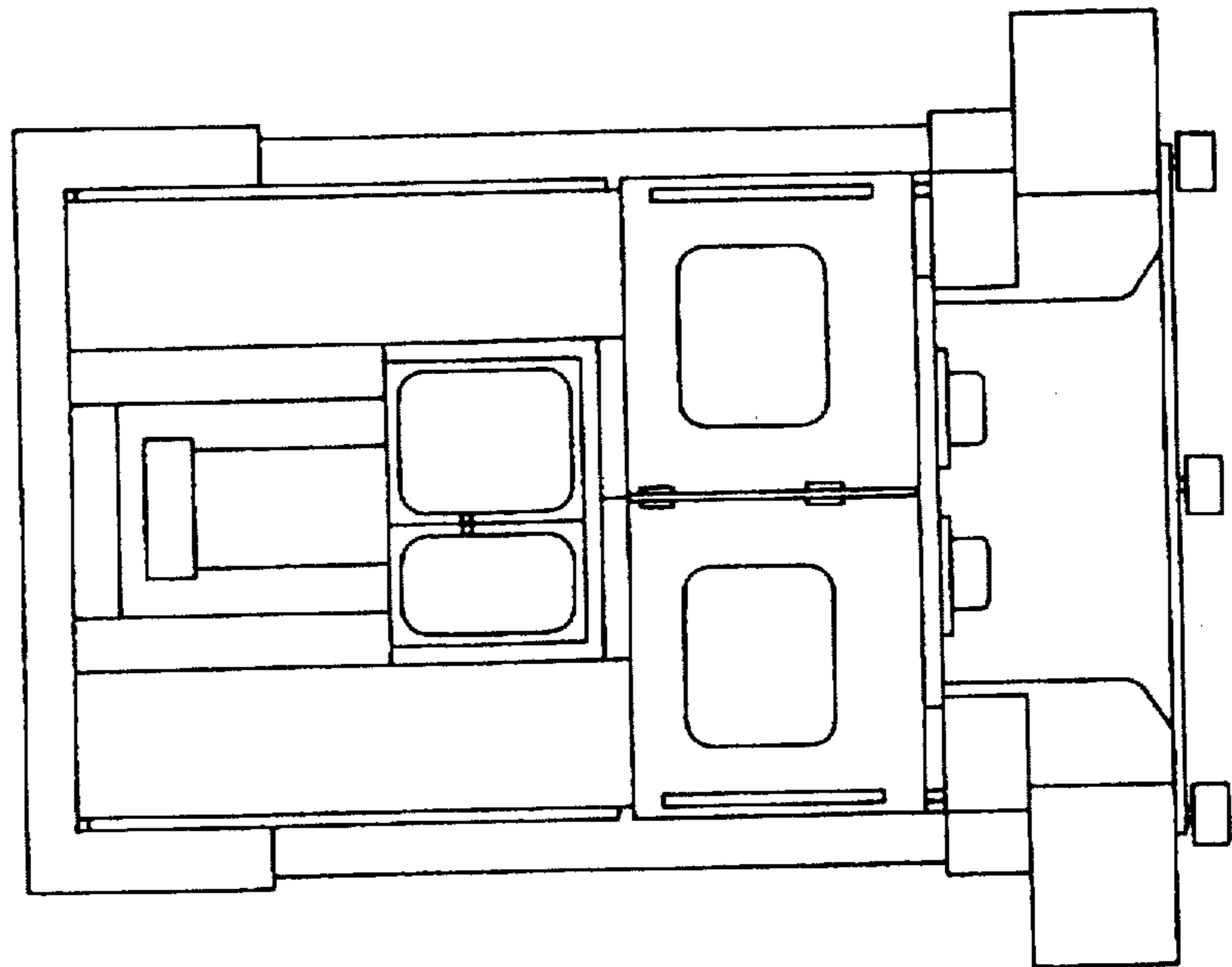

Fig. 109

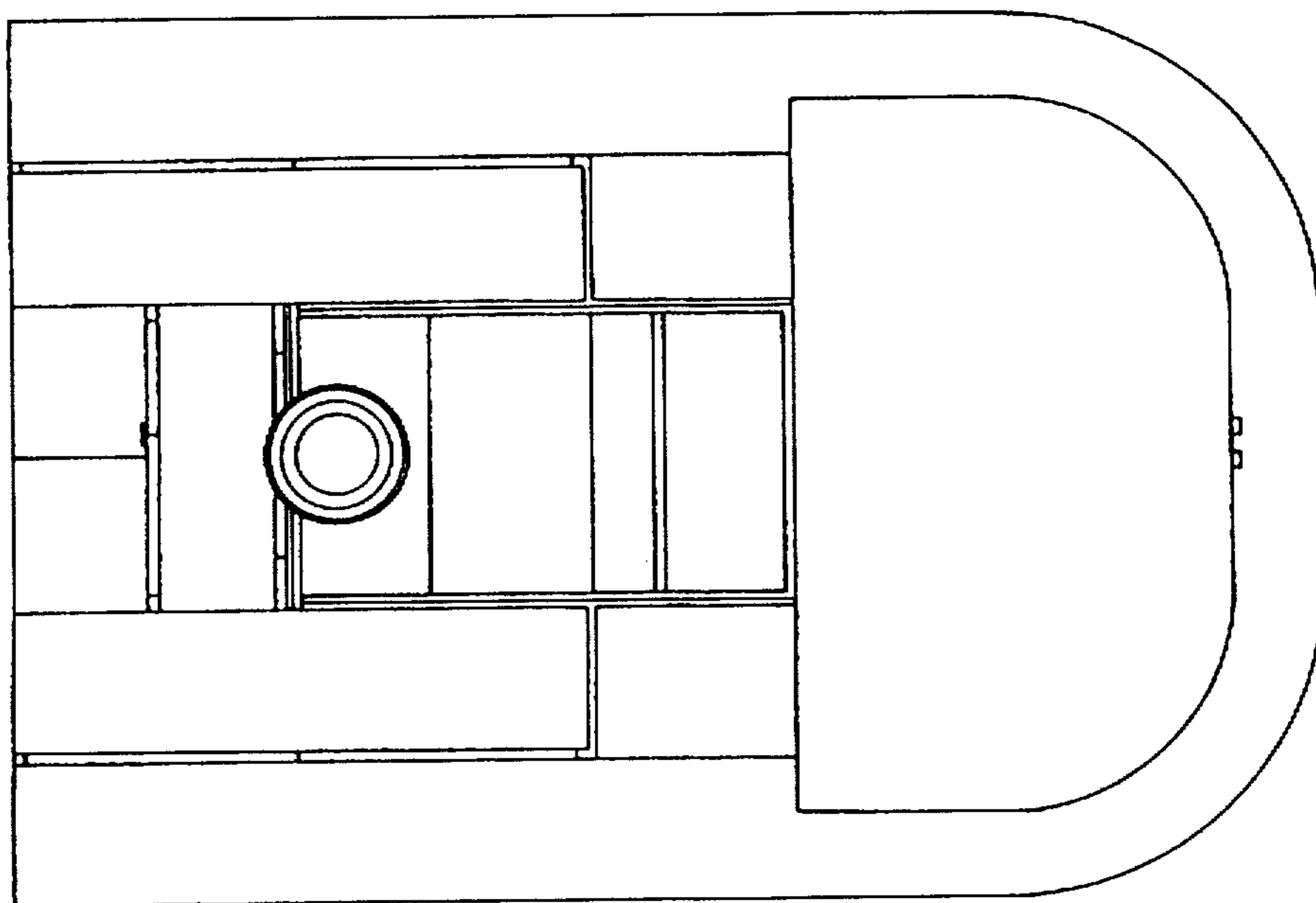

Fig. 110

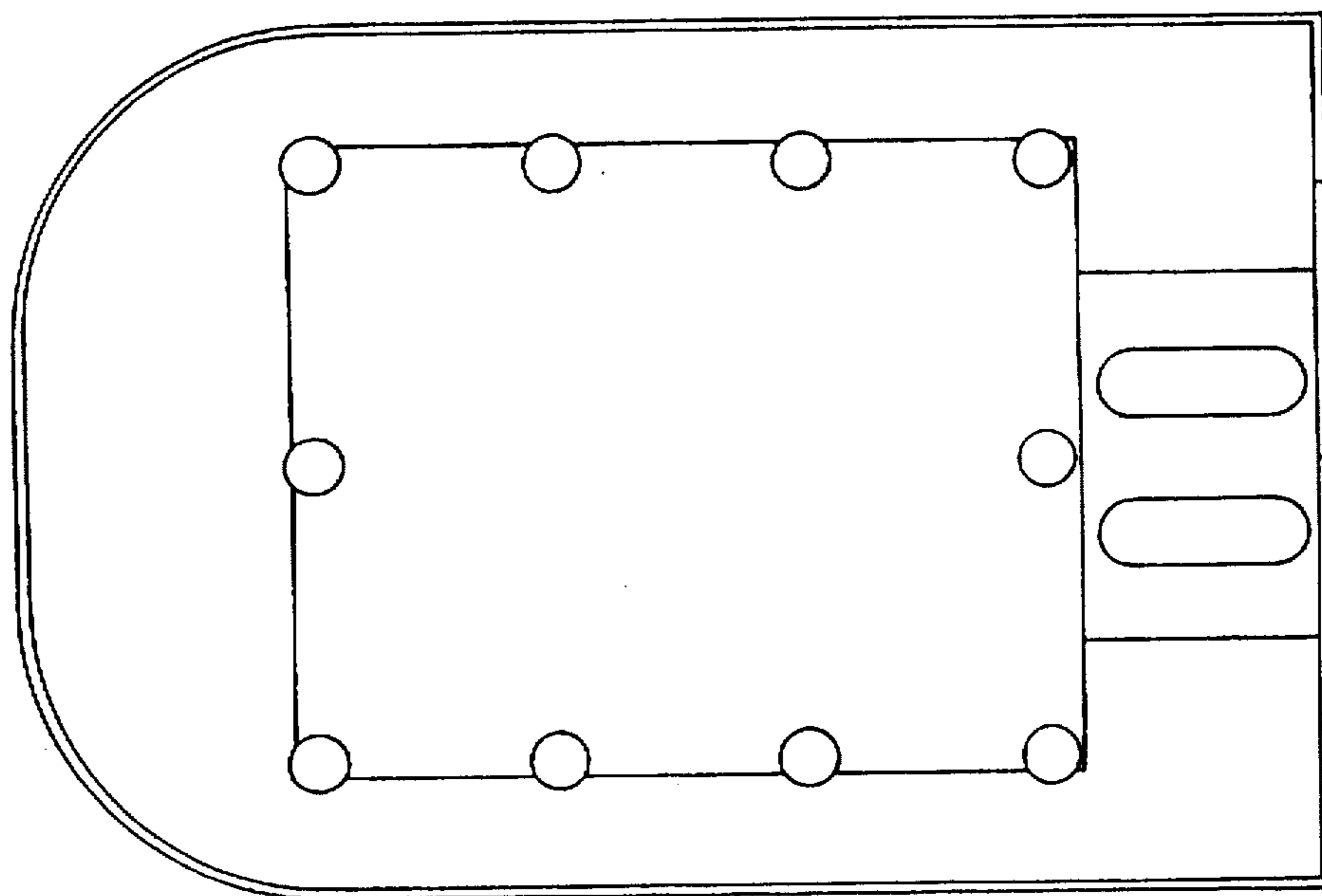

Fig. 111

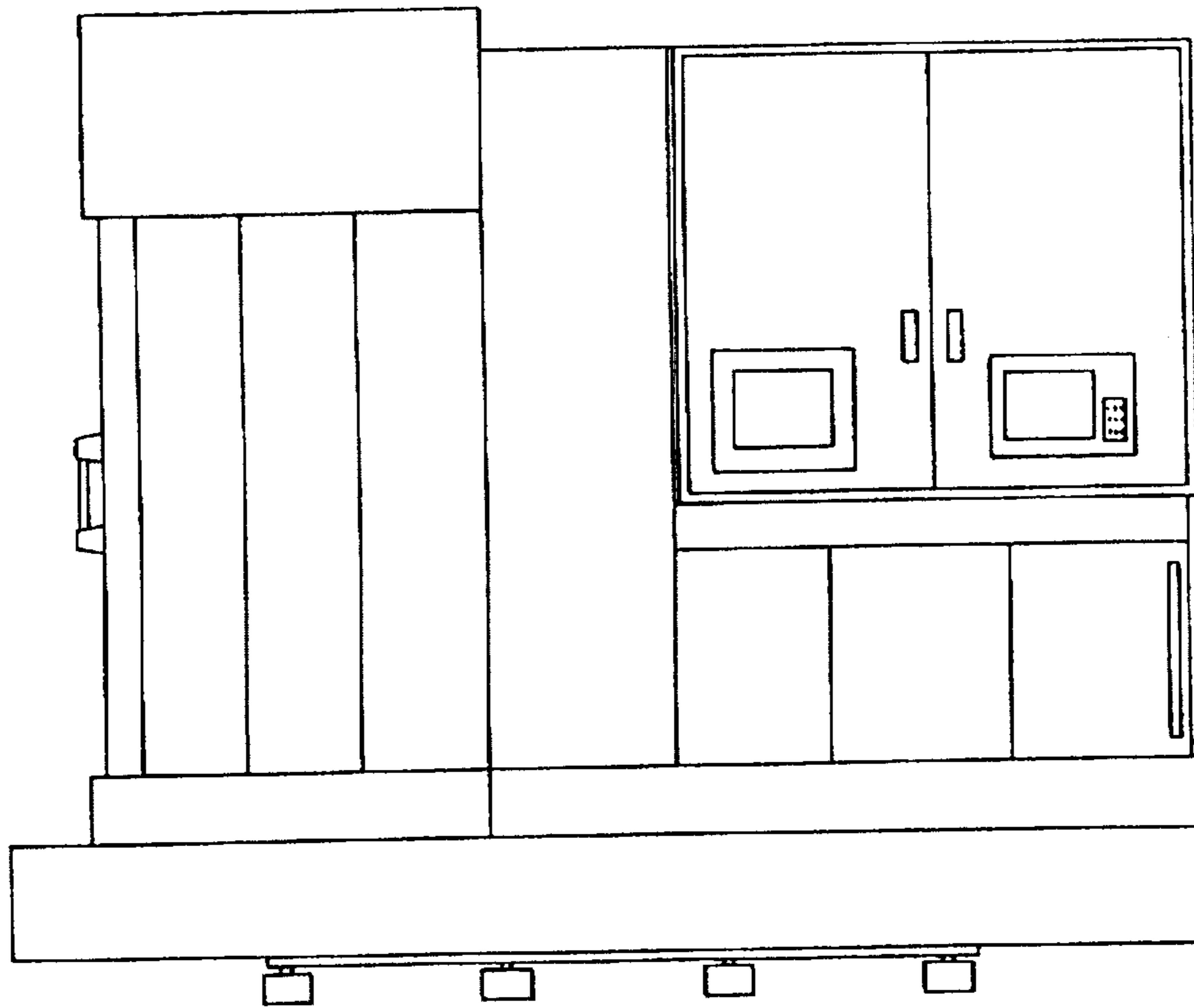

Fig. 112

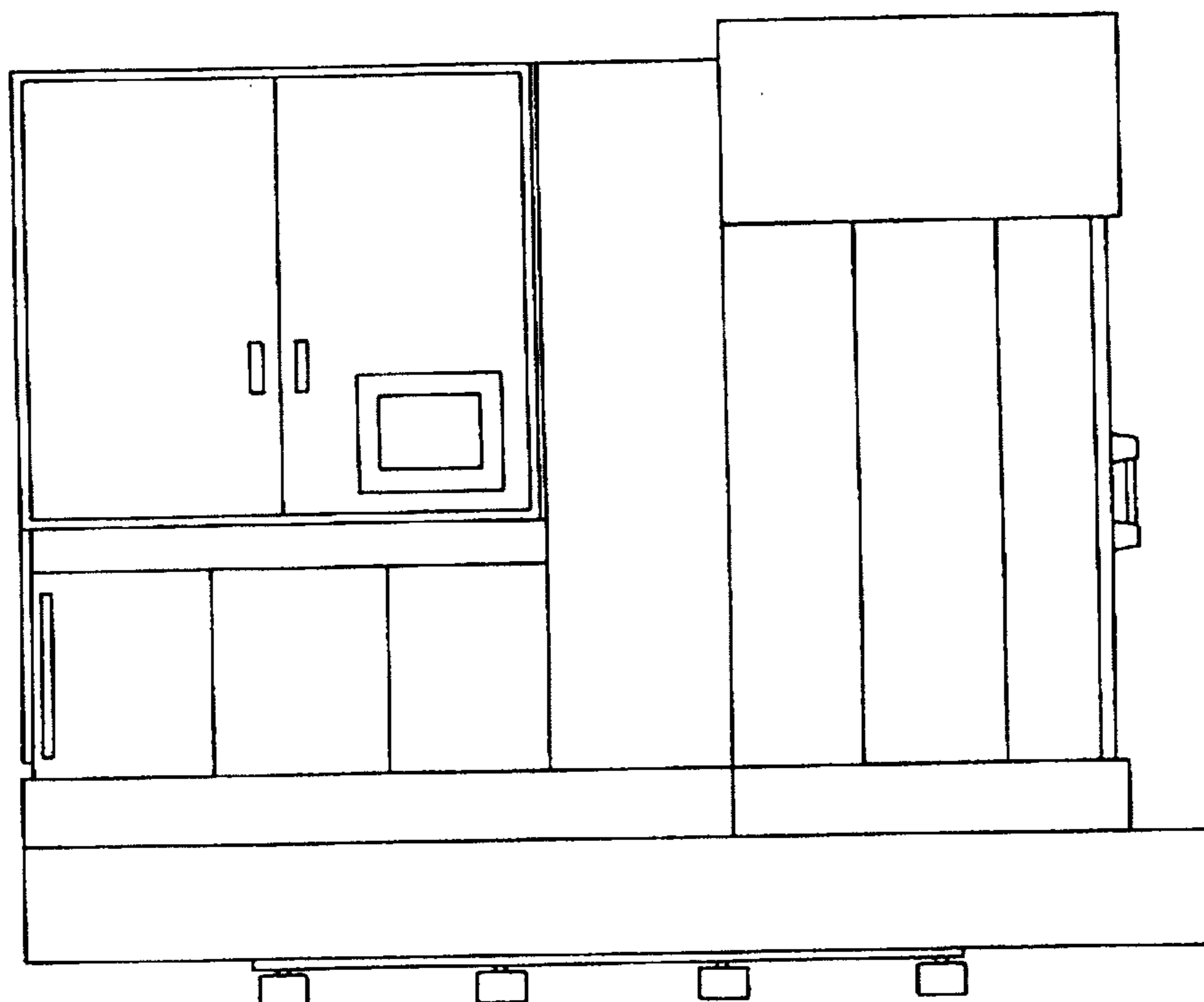

Fig. 113

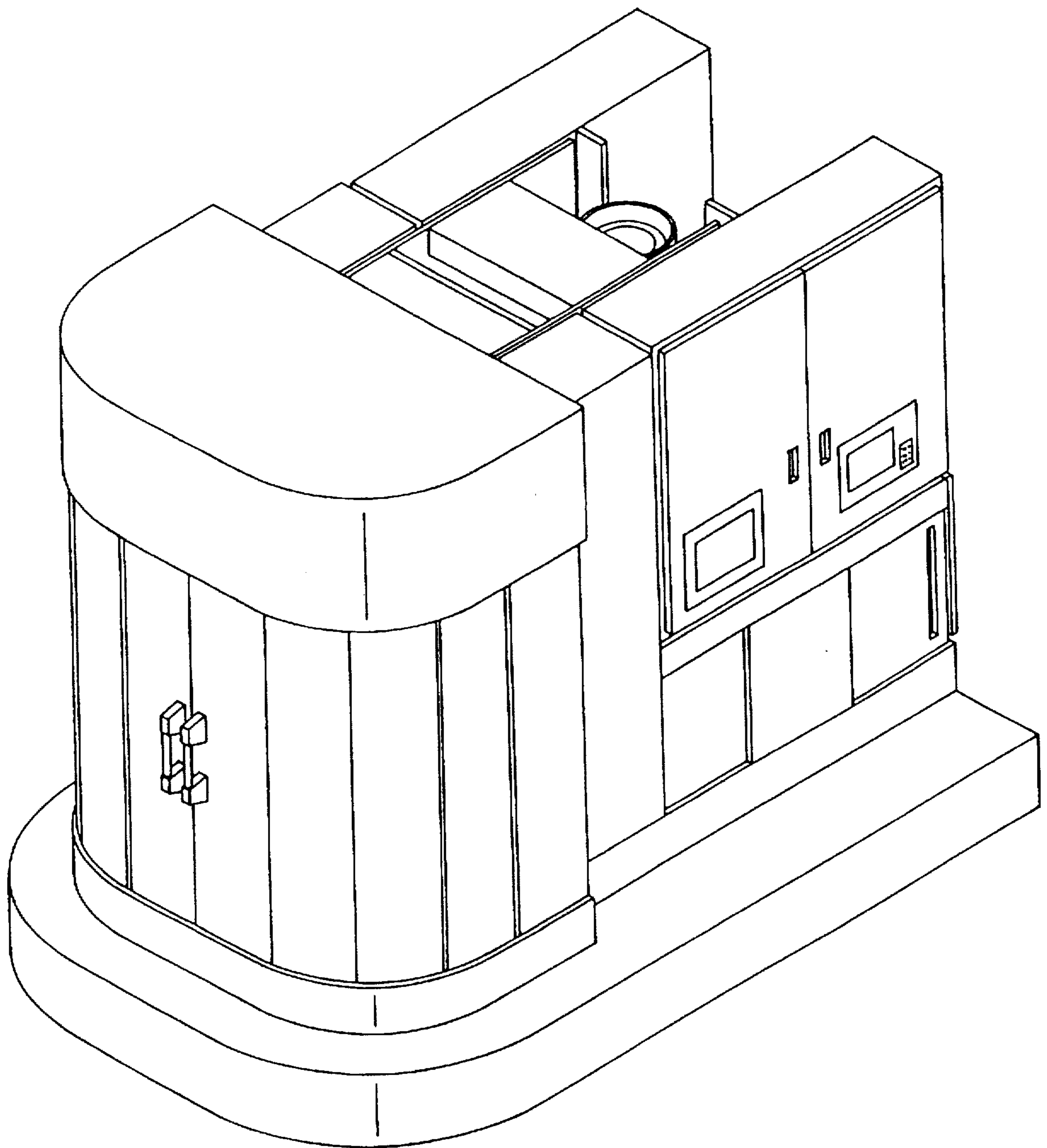

Fig. 114

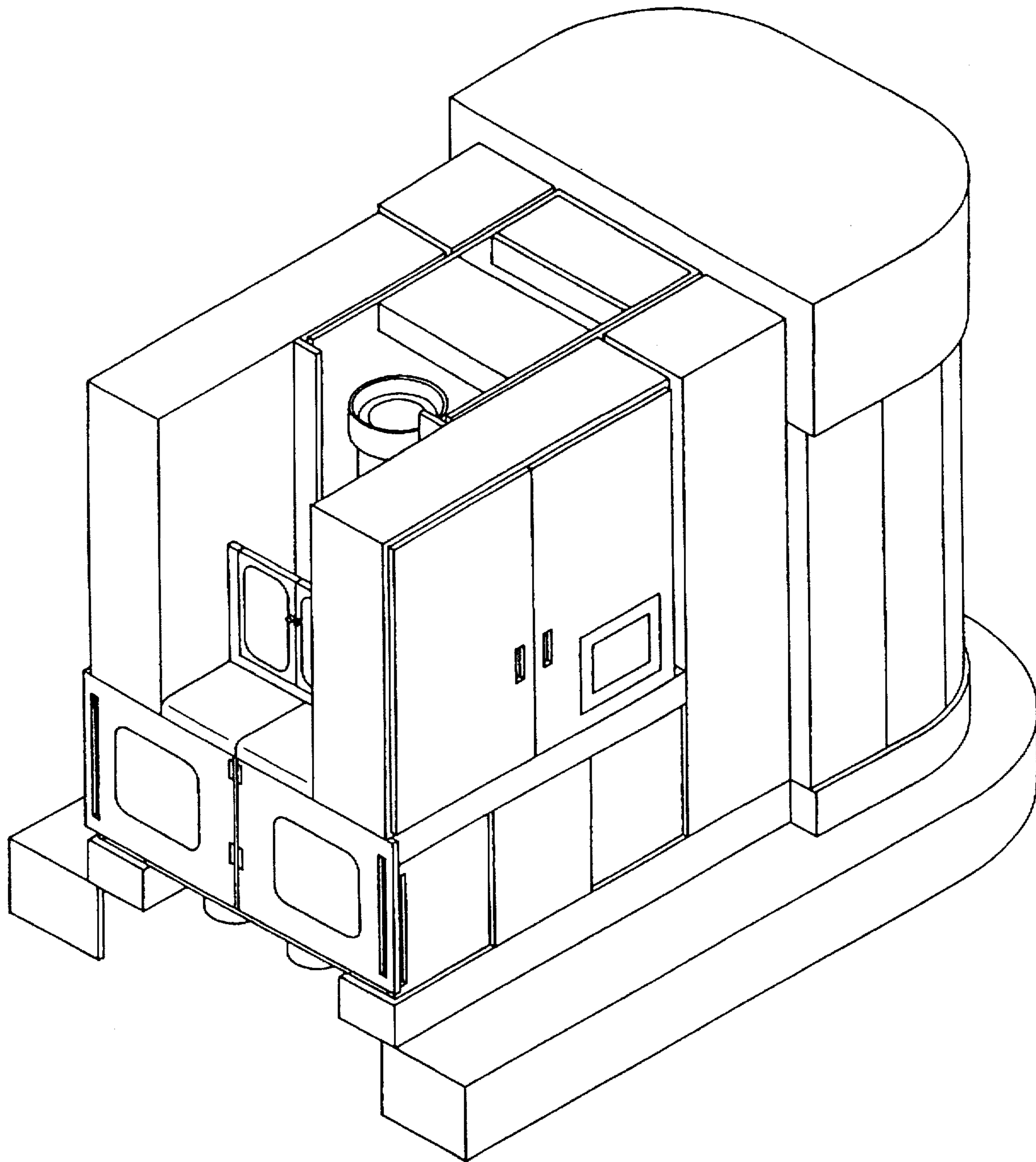

Fig. 115

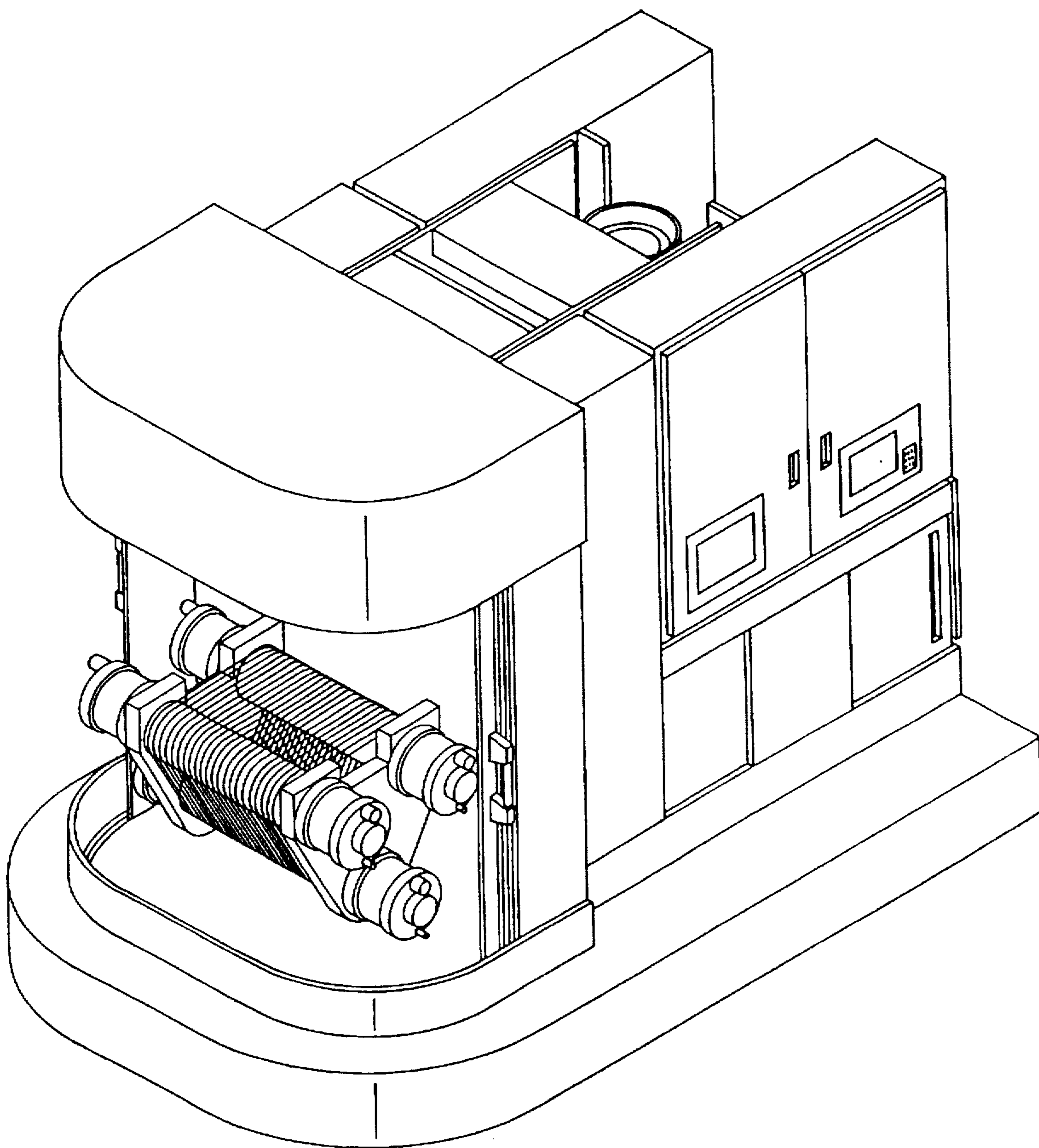

Fig. 116

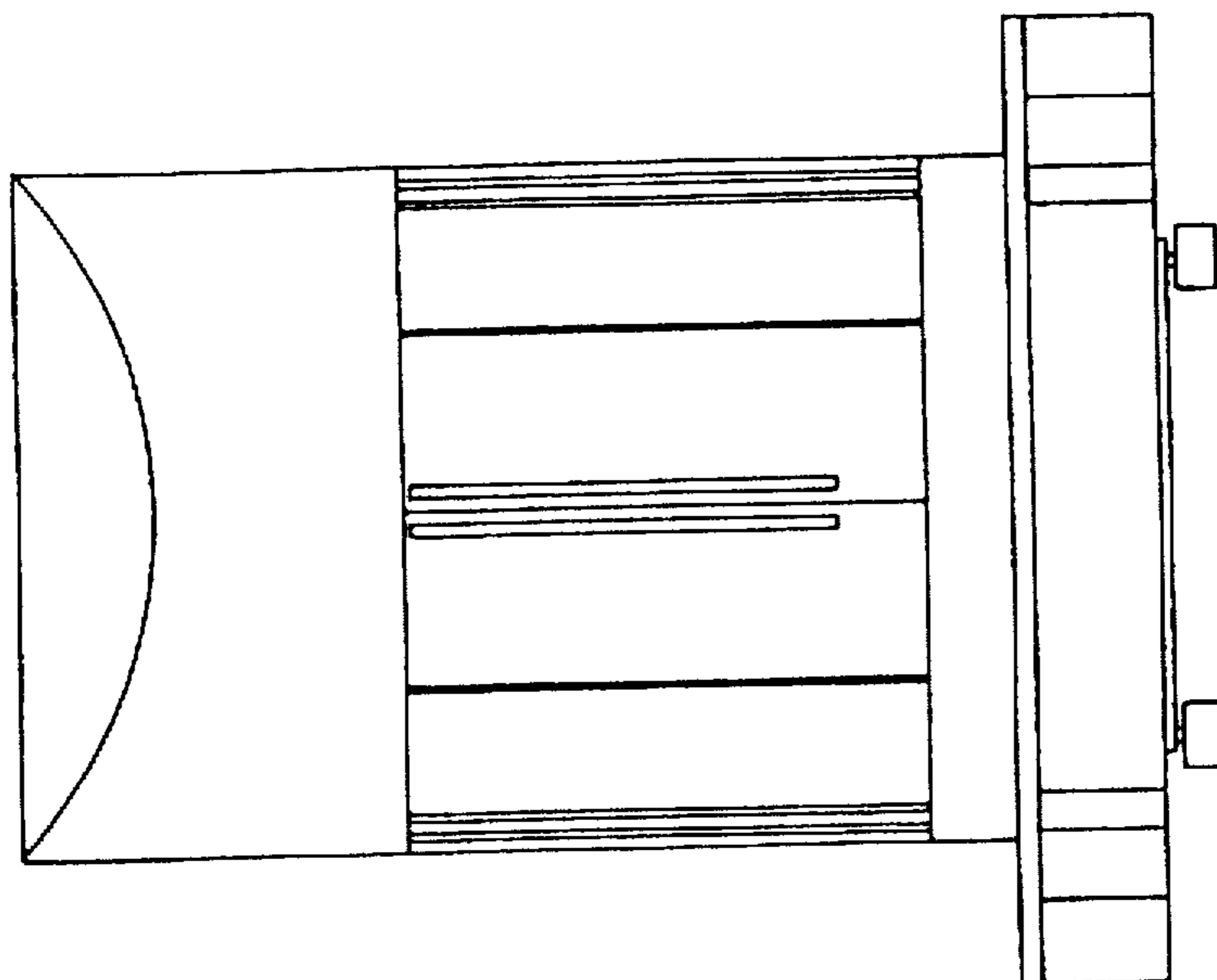

Fig. 117

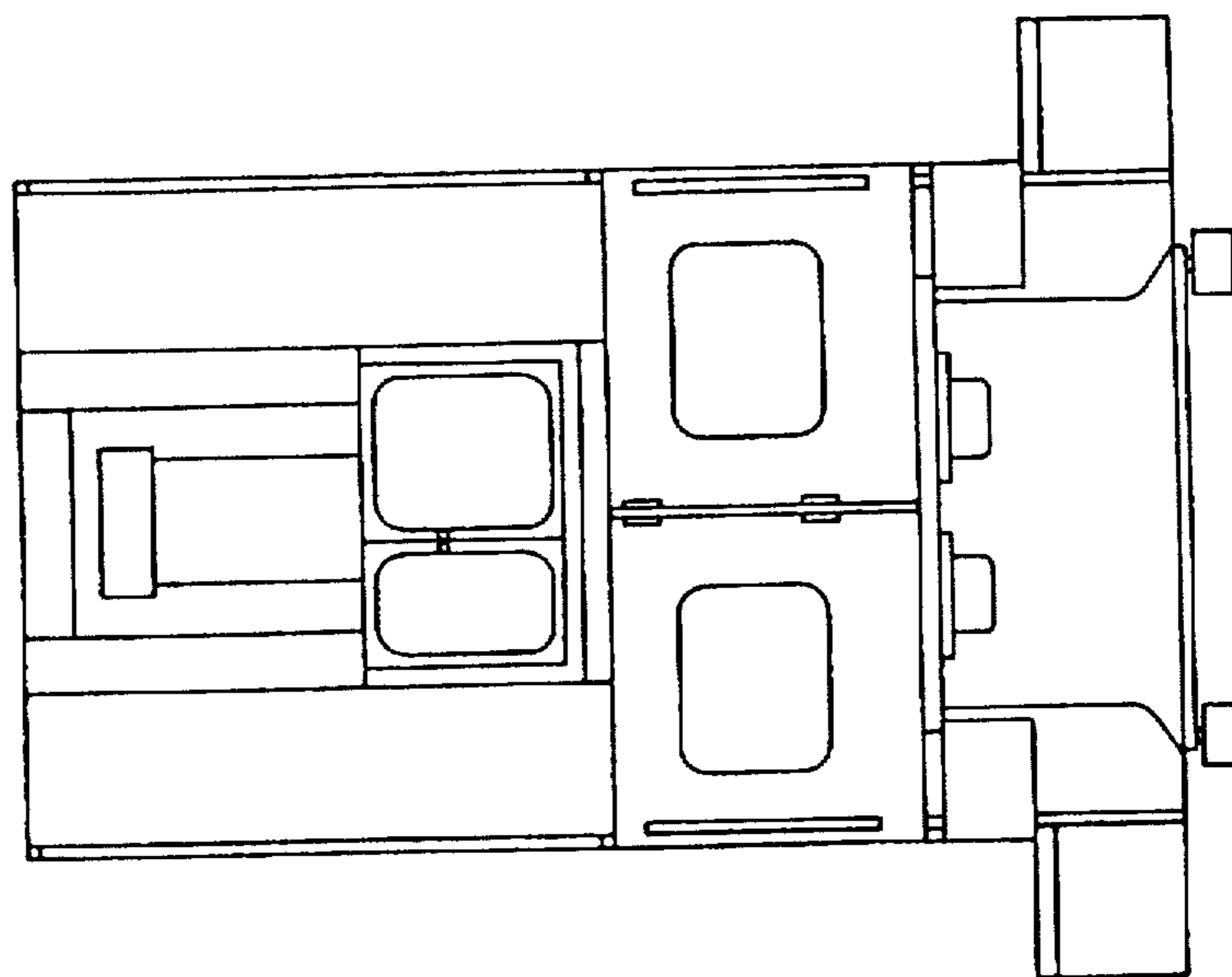

Fig. 118

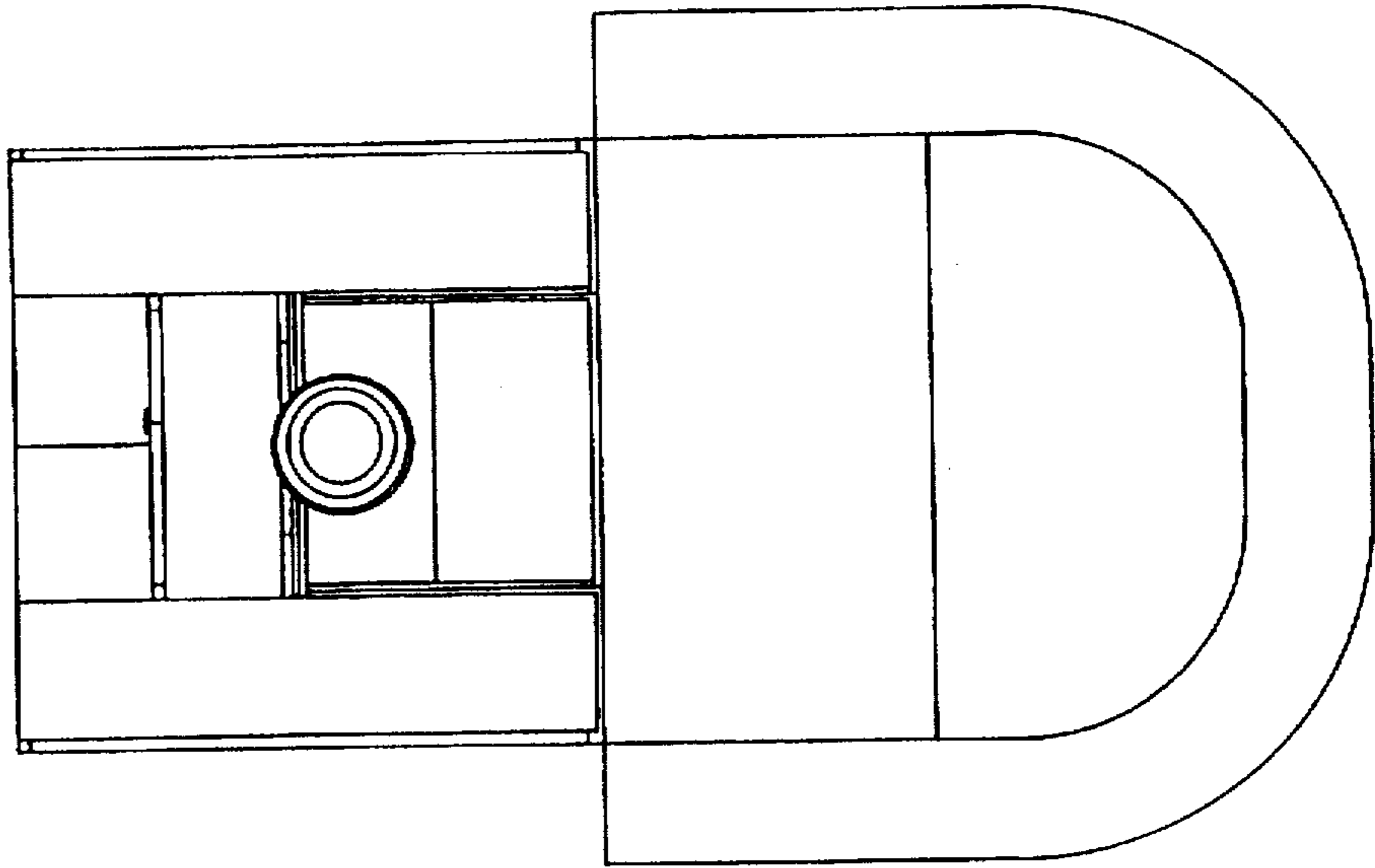

Fig. 119

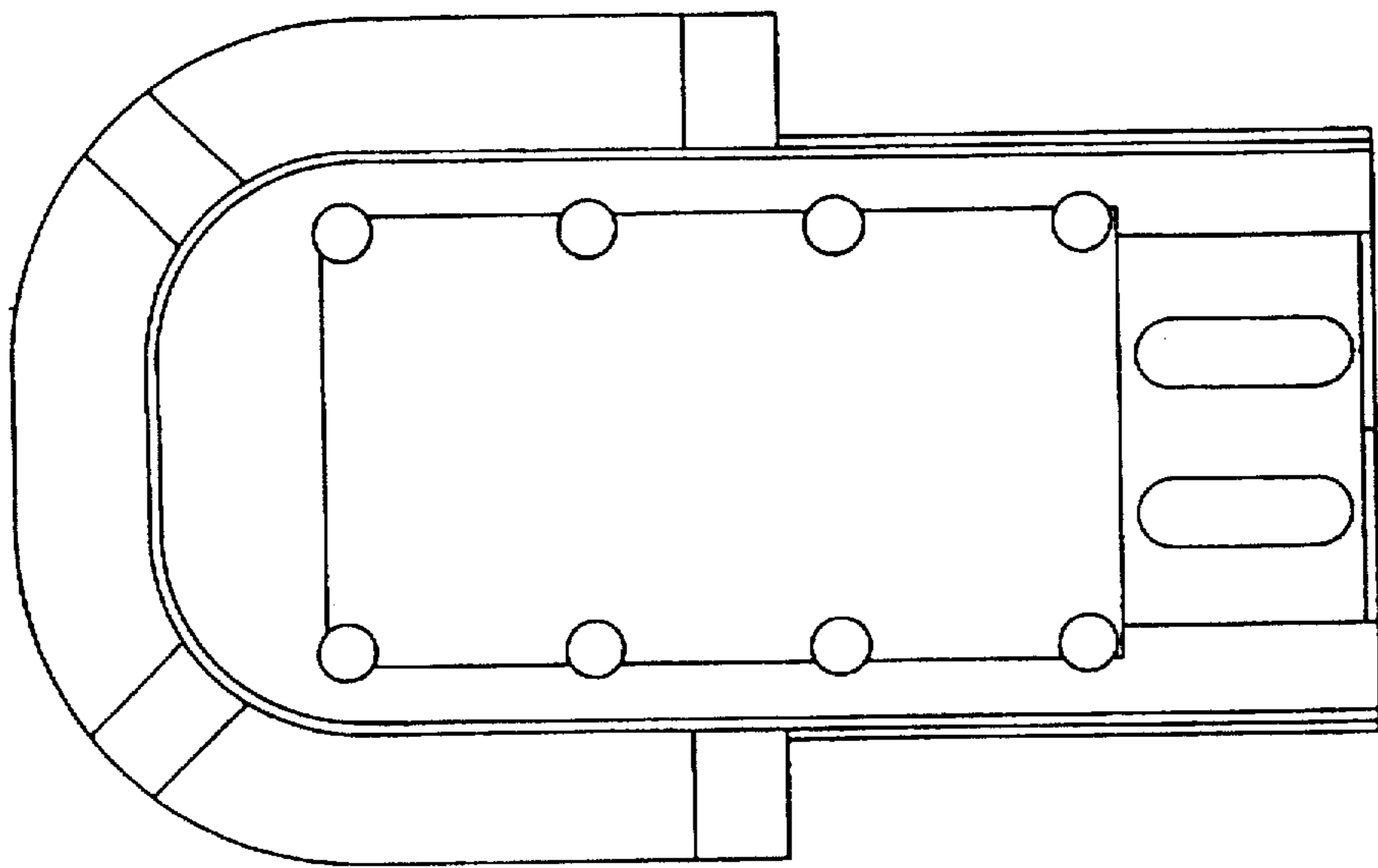

Fig. 120

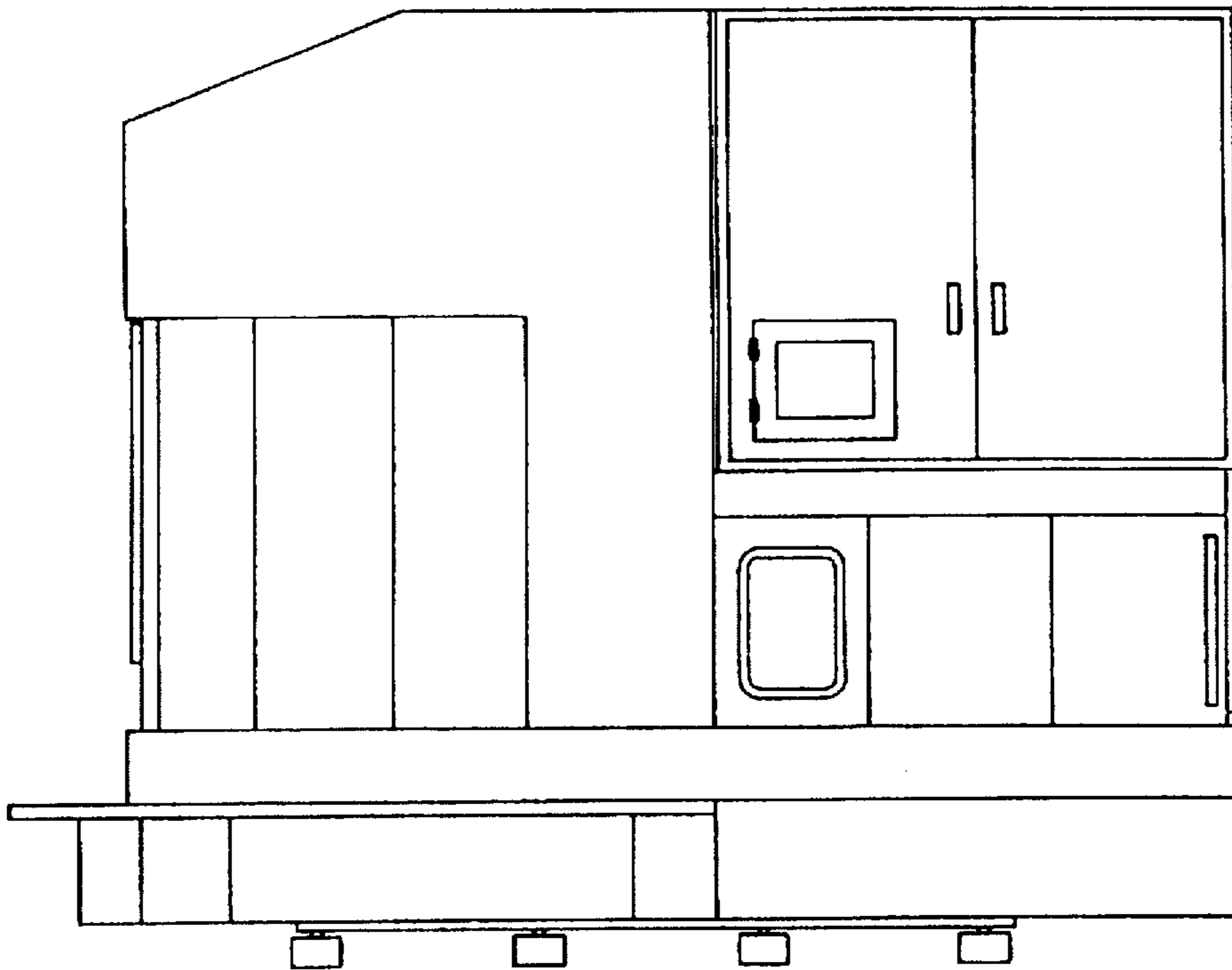

Fig. 121

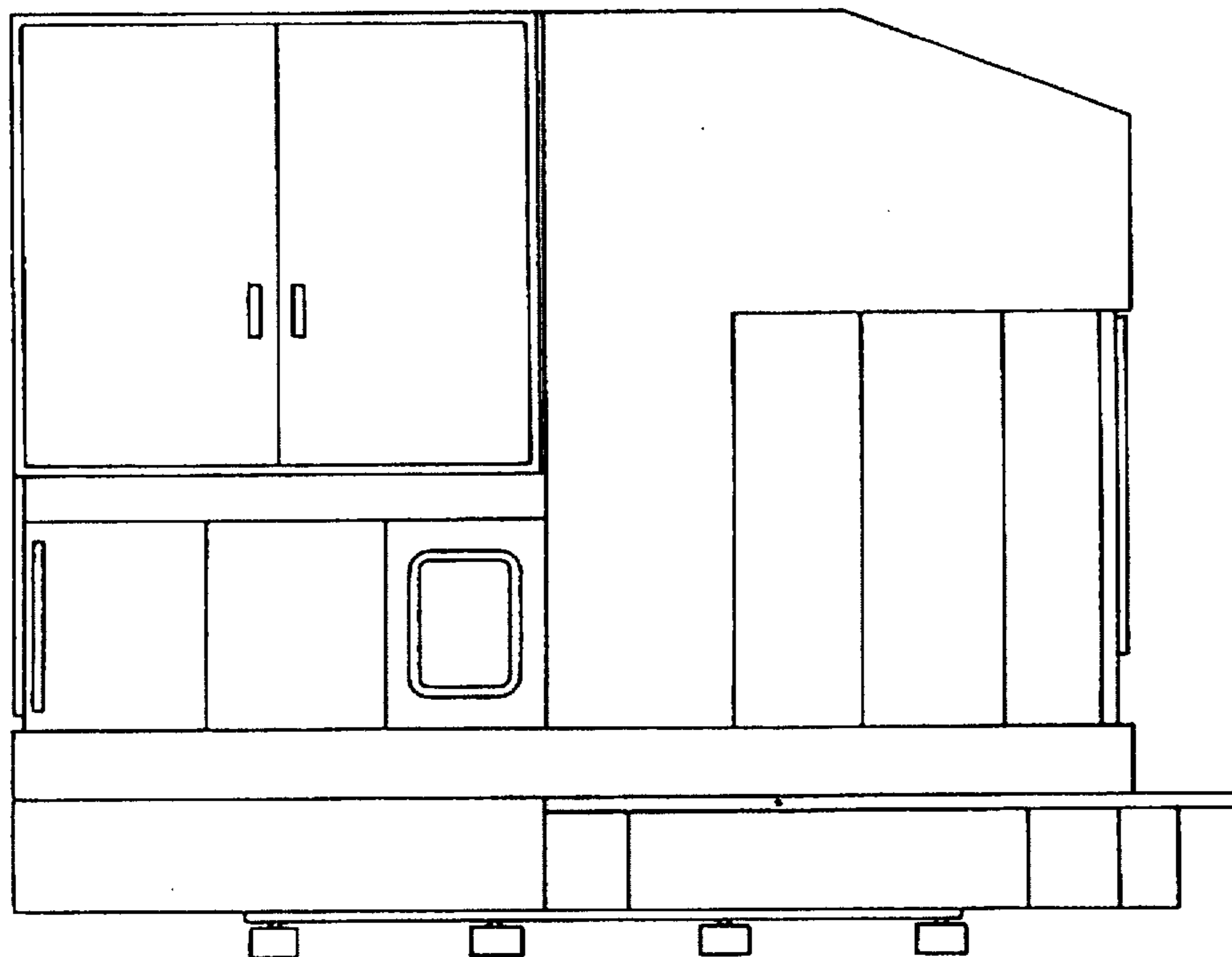

Fig. 122

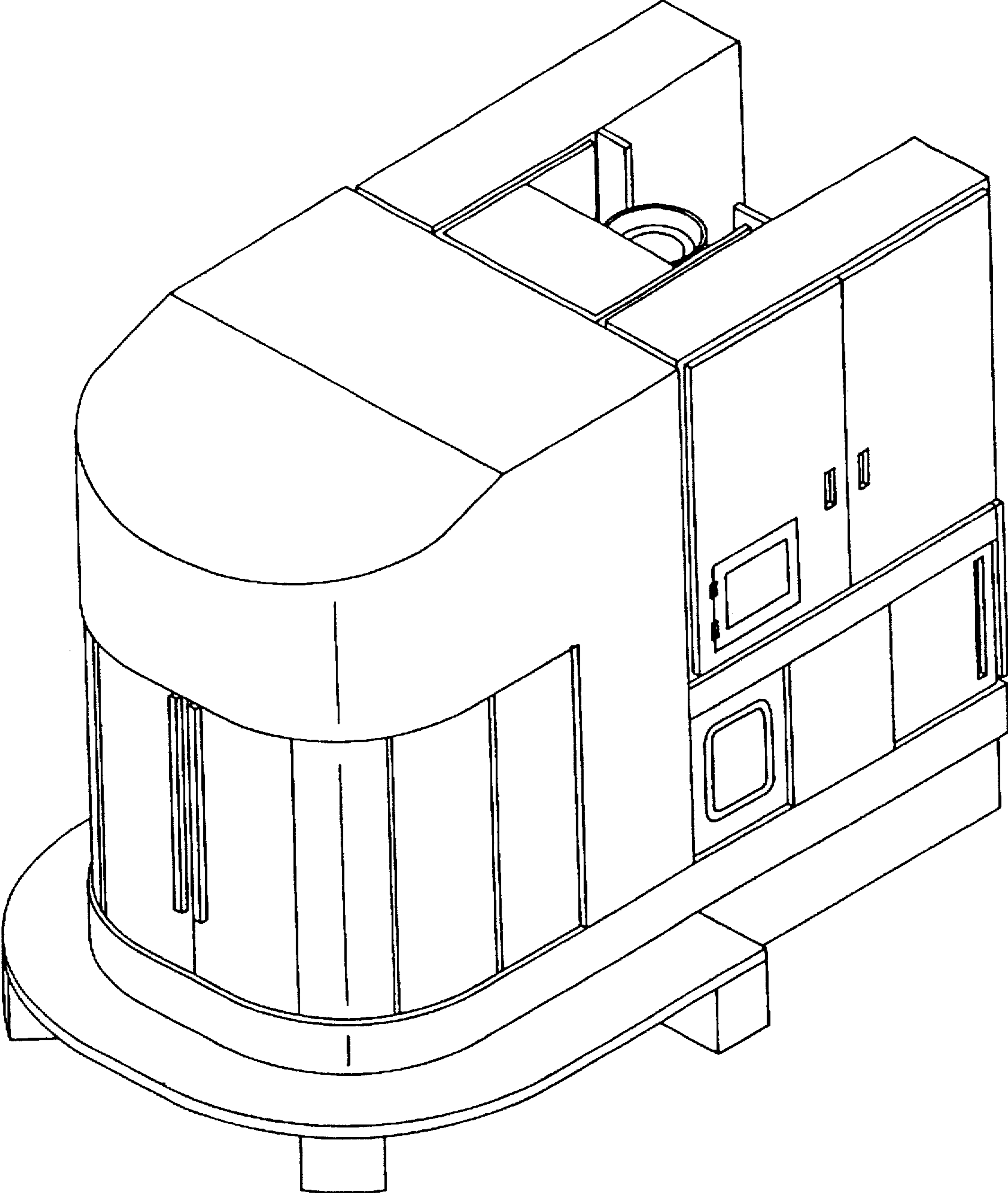

Fig. 123

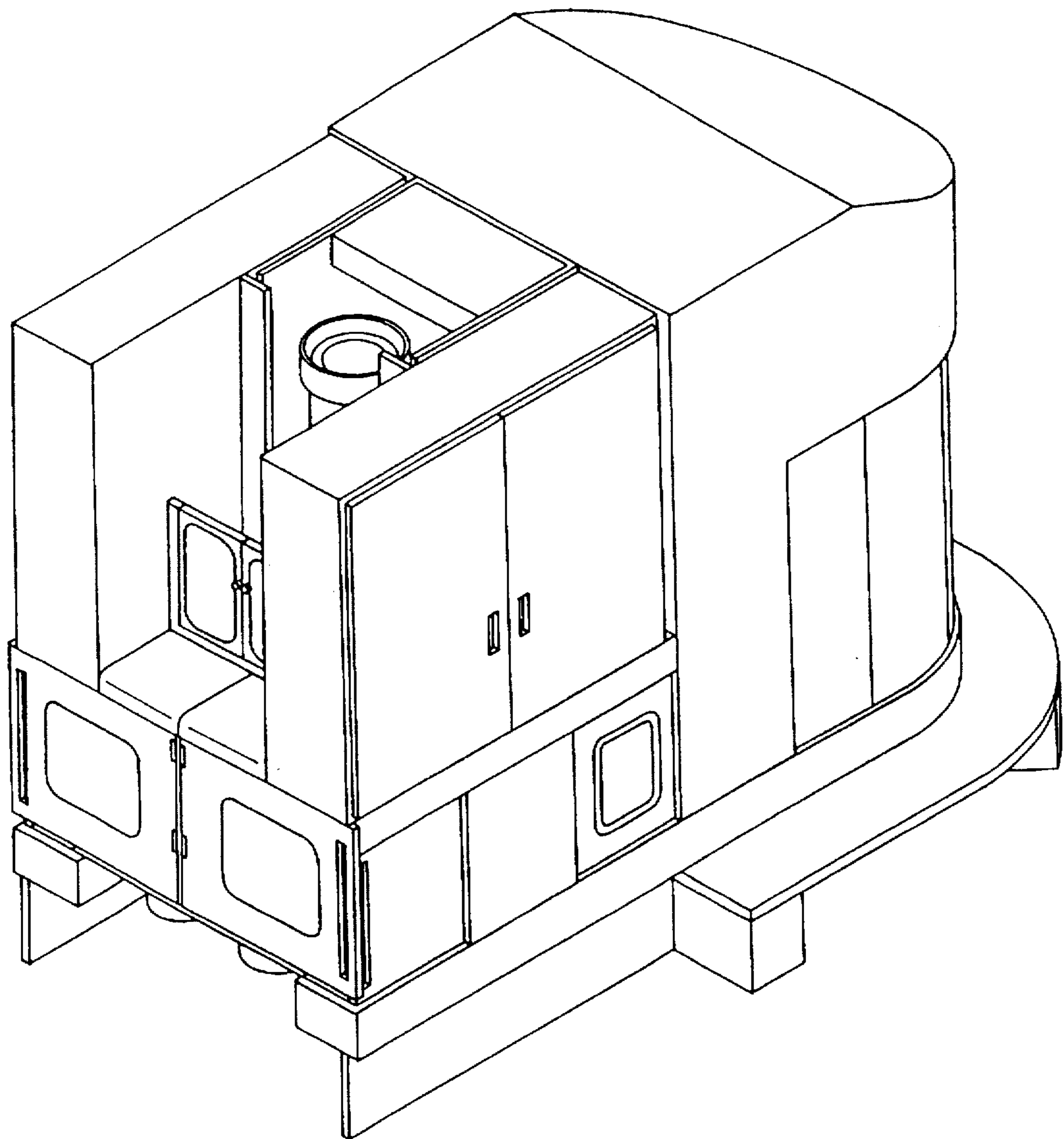

Fig. 124

