



US00D403388S

United States Patent [19]

Robins et al.

[11] Patent Number: Des. 403,388

[45] Date of Patent: **Dec. 29, 1998

[54] SET OF IN-LINE WHEELS

[75] Inventors: **Duncan G. Robins**, Woodland Hills;
Richard D. Grossman, Grenada Hills,
both of Calif.

[73] Assignee: **Jas D. Easton, Inc.**, Van Nuys, Calif.

[**] Term: **14 Years**

[21] Appl. No.: **76,950**

[22] Filed: **Sep. 19, 1997**

[51] LOC (6) Cl. **21-02**

[52] U.S. Cl. **D21/779**

[58] Field of Search D21/224-227;
280/11.19, 11.2, 11.22, 11.26-11.28, 809,
841, 843; 301/5.3, 5.7

[56] **References Cited**

U.S. PATENT DOCUMENTS

D. 321,393	11/1991	Olson et al.	D21/226
D. 324,713	3/1992	Rubin	D21/226
D. 325,417	4/1992	McNamara et al.	D21/226
1,778,850	10/1930	Duisenberg .	
2,570,349	10/1951	Kardhordo	280/11.22
5,207,454	5/1993	Blankenburg et al.	280/843

5,271,633	12/1993	Hill, Jr.	280/11.22
5,286,043	2/1994	Tkaczyk	280/11.22
5,385,356	1/1995	Conte	280/11.22
5,388,846	2/1995	Gierveld	280/11.22
5,413,362	5/1995	De Santis	280/11.2
5,492,345	2/1996	Kruczek	280/11.15
5,551,713	9/1996	Alexander	280/11.19

Primary Examiner—Sandra L. Morris
Attorney, Agent, or Firm—Lyon & Lyon LLP

[57] **CLAIM**

The ornamental design for a set of in-line wheels, as shown and described.

DESCRIPTION

FIG. 1 is a side elevational view of a set of in-line wheels, showing our new design;
FIG. 2 is a side elevational view of a second embodiment of the design in FIG. 2;
FIG. 3 is a top plan view of both of the embodiments thereof;
FIG. 4 is a front elevational view thereof;
FIG. 5 is a bottom plan view thereof; and,
FIG. 6 is a rear elevational view thereof.

The broken line showing of the skate is for illustrative purposes only, and forms no part of the claimed design.

1 Claim, 4 Drawing Sheets

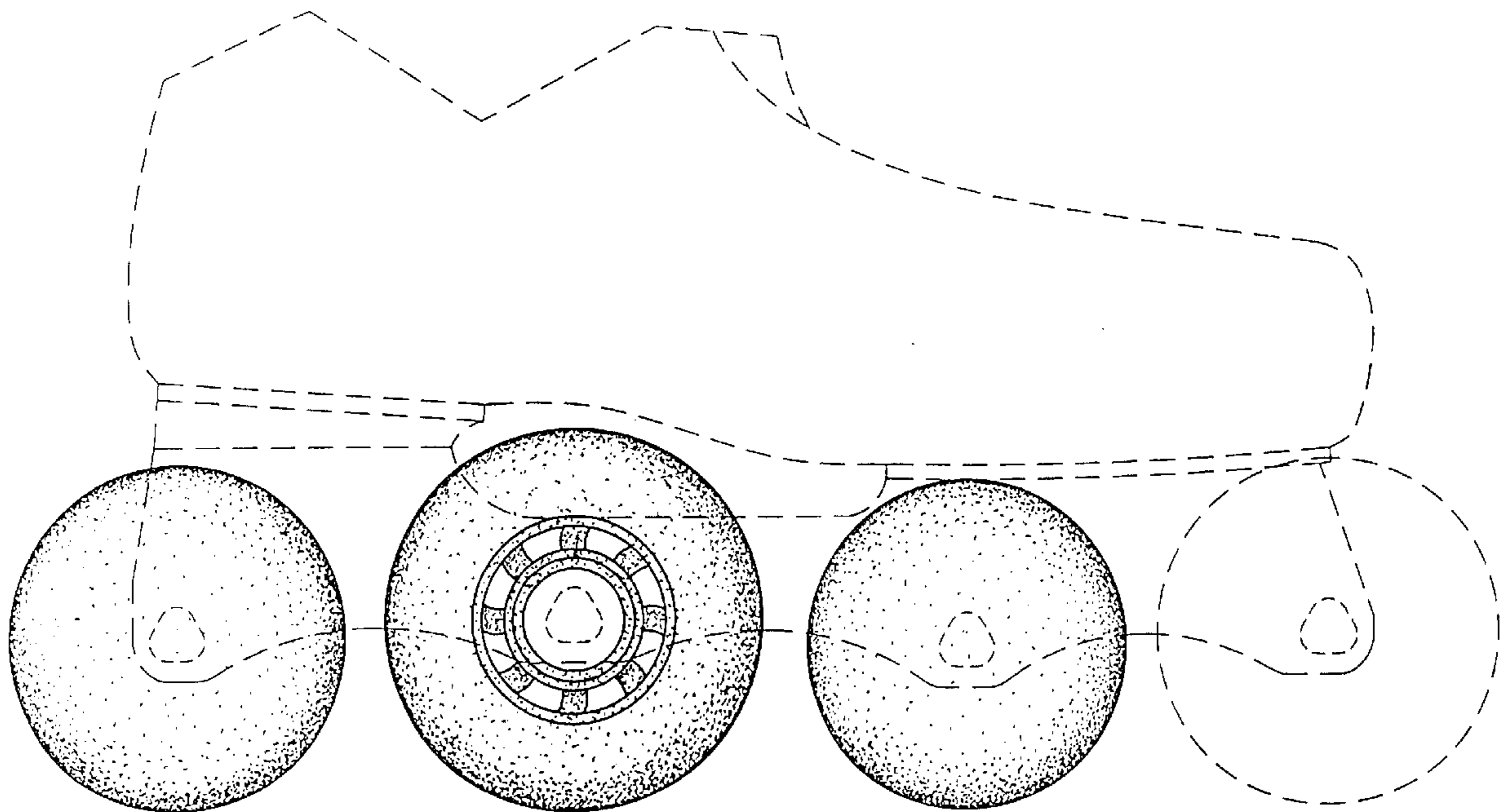

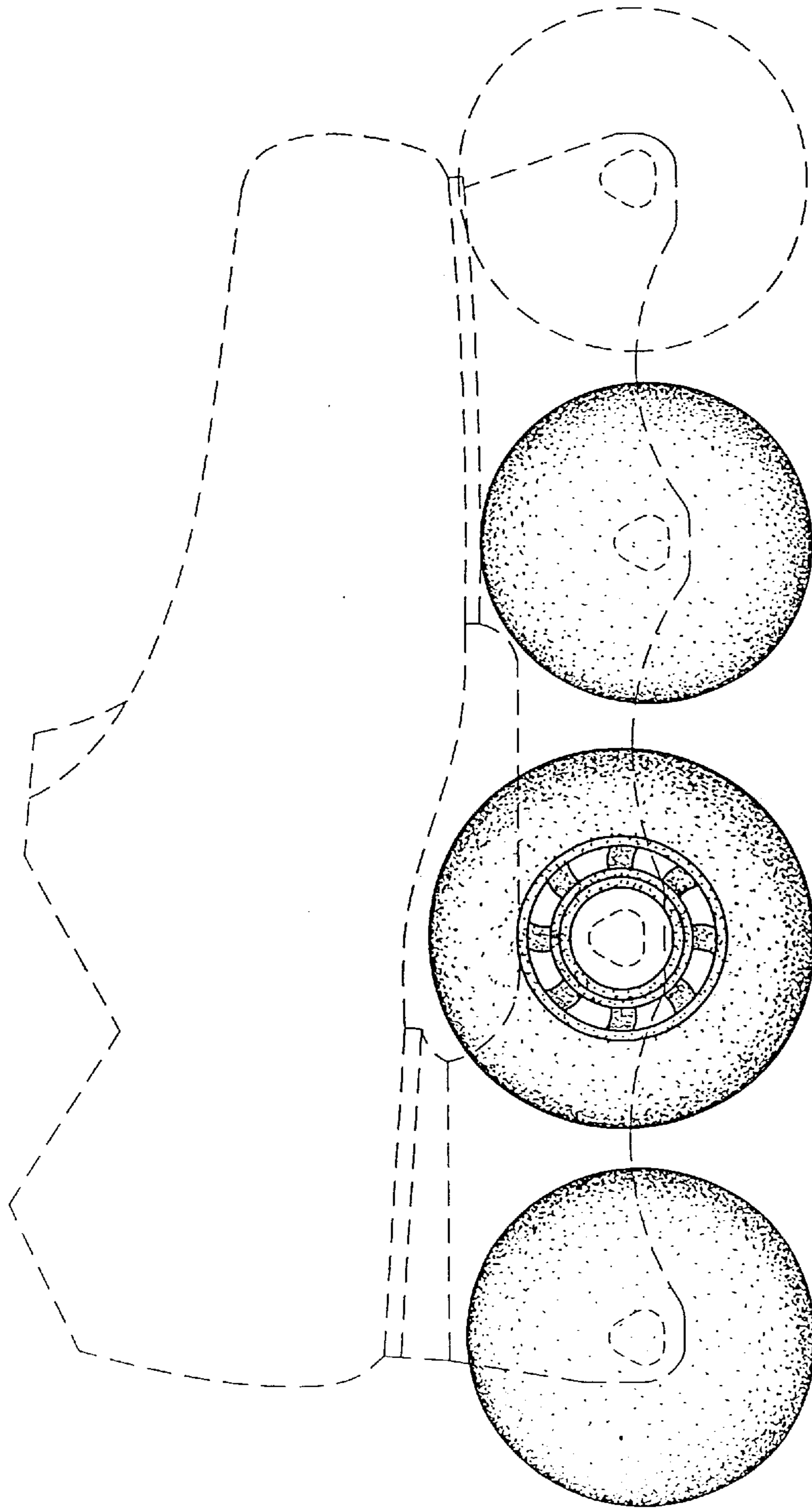

Fig. 1

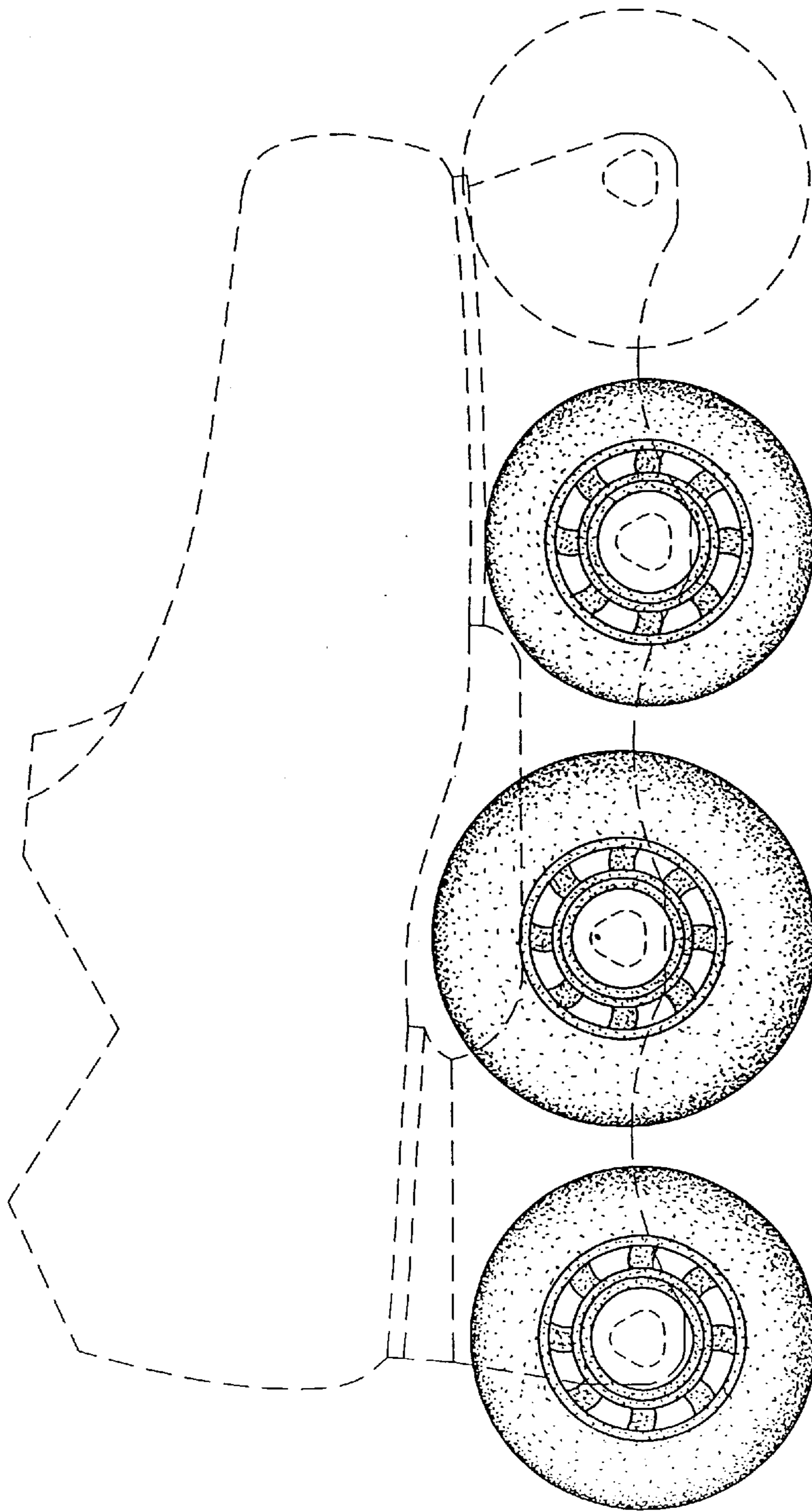

Fig. 2

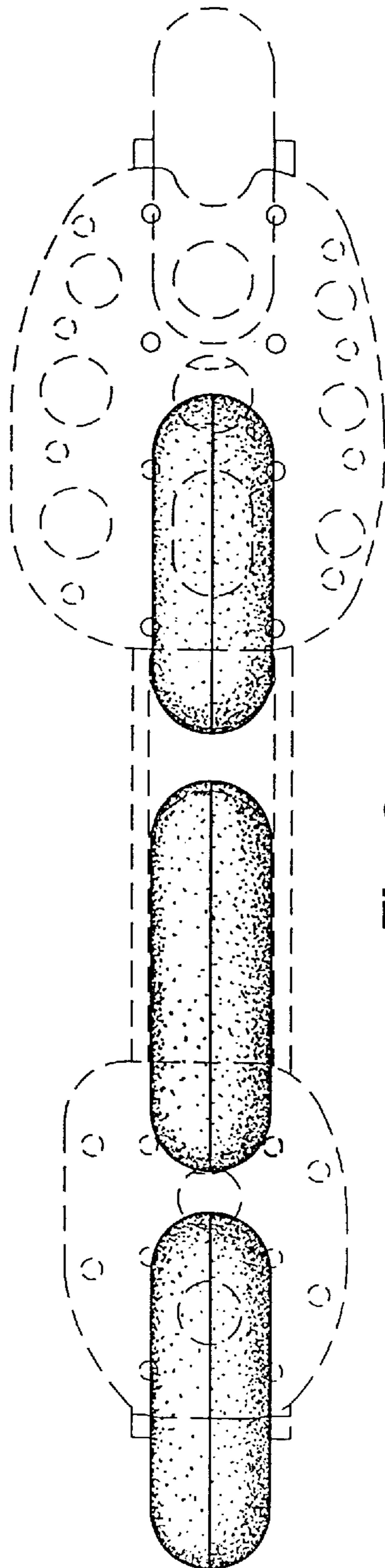

Fig. 3

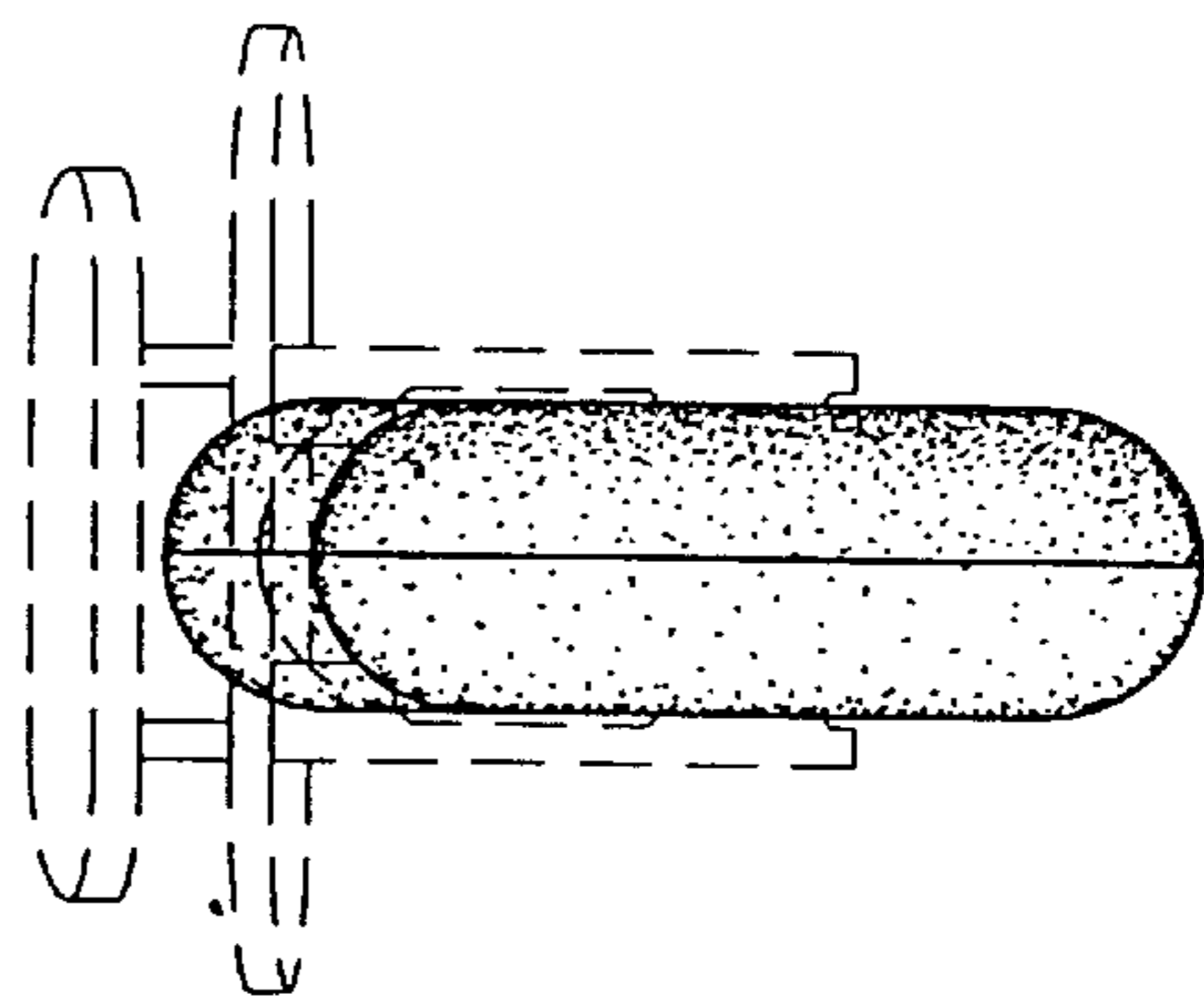

Fig. 4

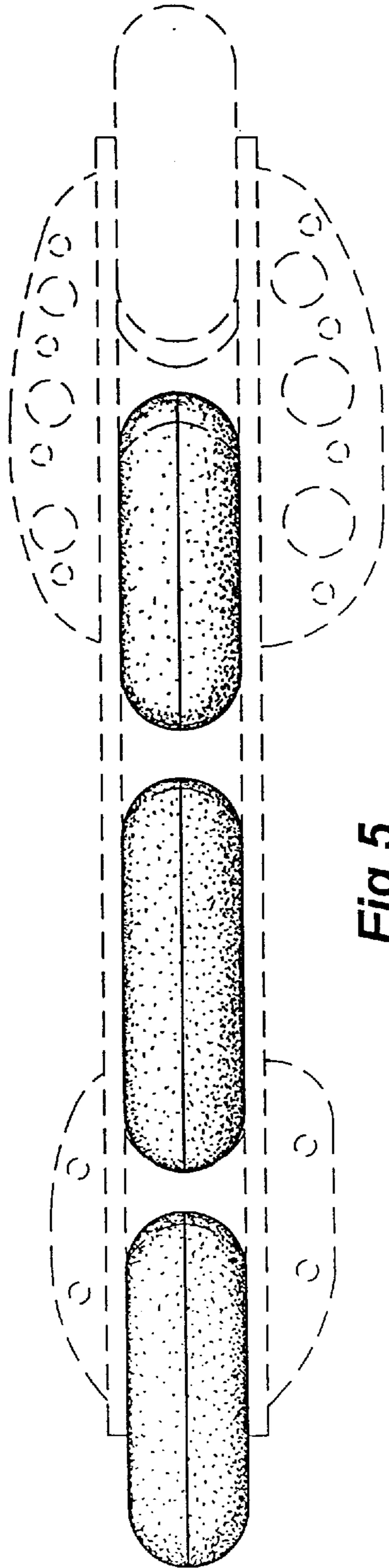

Fig. 5

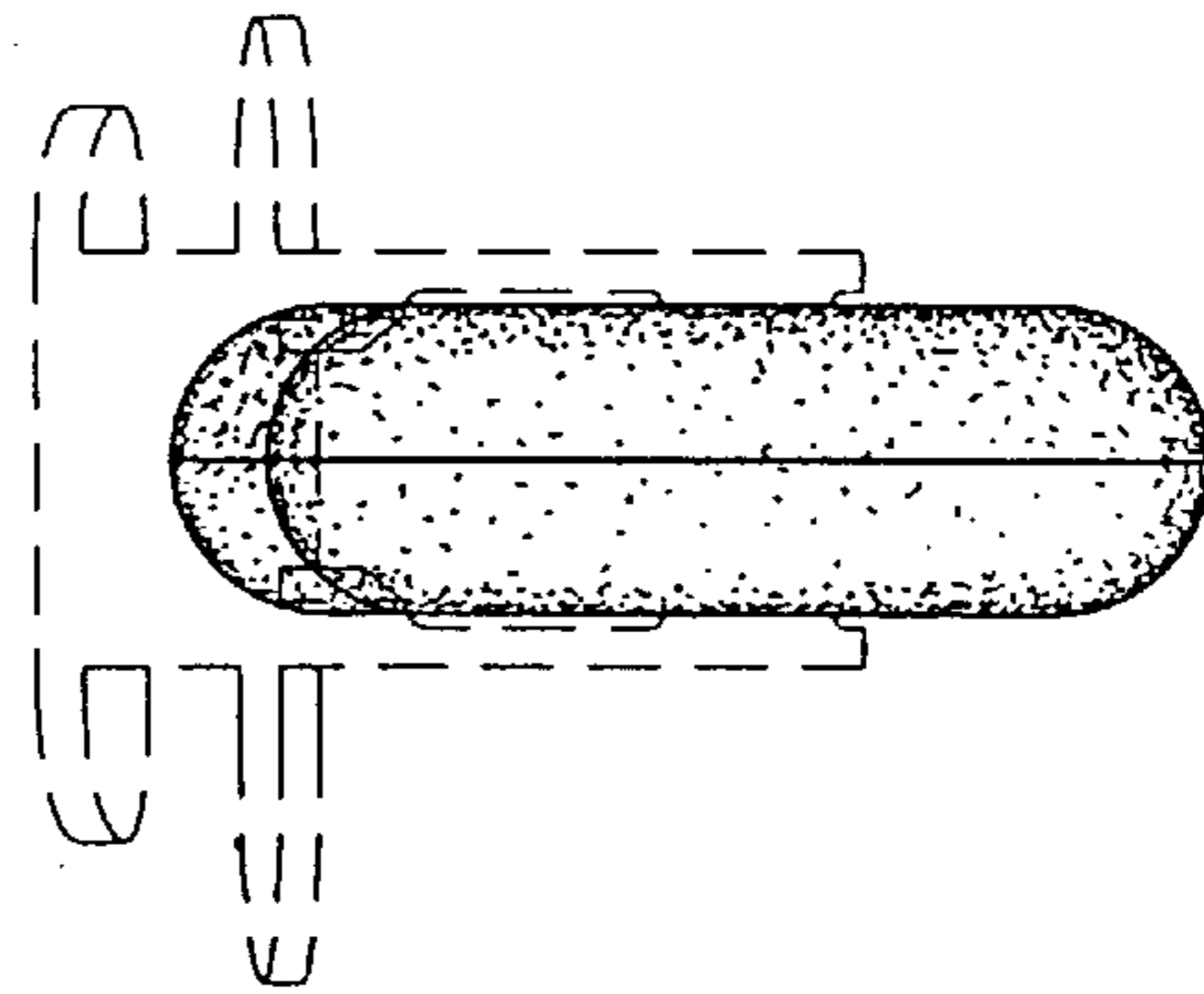

Fig. 6