



US00D403216S

United States Patent [19]

[11] **Patent Number: Des. 403,216**

Romine et al.

[45] **Date of Patent: **Dec. 29, 1998**

[54] **WELDING GUN HANDLE AND HOUSING**

[75] Inventors: **Gary L. Romine**, Emporia; **Dale Robert Bervig**, Wichita, both of Kans.

[73] Assignee: **Tweco Products, Inc.**, Wichita, Kans.

[**] Term: **14 Years**

[21] Appl. No.: **76,234**

[22] Filed: **Sep. 5, 1997**

[51] **LOC (6) Cl. 08-05**

[52] **U.S. Cl. D8/30**

[58] **Field of Search D8/30; 219/137.31-137.63, 219/136, 221, 227**

[56] **References Cited**

U.S. PATENT DOCUMENTS

D. 303,070	8/1989	Hinden et al.	D8/30
3,629,547	12/1971	Kester .	
4,954,690	9/1990	Kensrue	219/137.31
5,326,958	7/1994	Geus	219/137.31
5,491,321	2/1996	Stuart et al. .	

OTHER PUBLICATIONS

Binzel brochure entitled "MIG Equipment", published before Sep. 5, 1997.

Binzel sales literature entitled "Push-Pull Welding Gun PP 24 D / 26 D / 36 D"; published before Sep. 5, 1997.

Hobart Welding Products sales literature entitled "Olympic 30A Semiautomatic Wire Feed System"; published before Sep. 5, 1997.

Hulfegger sales literature, published before Sep. 5, 1997. Nu-Tecsys Corp. brochure entitled PULLMIG 26/PULLMIG 501 published before Sep. 5, 1997.

MK Products, Inc. sales literature entitled "Cobramatic Specifications", published before Sep. 5, 1997.

Tweco sales literature entitled "Heavy-Range Mig-Guns", published before Sep. 5, 1997.

Primary Examiner—Terry A. Wallace

Attorney, Agent, or Firm—Senniger, Powers, Leavitt & Roedel

[57] **CLAIM**

The ornamental design for a welding gun handle and housing, as shown and described.

DESCRIPTION

FIG. 1 is a right side elevational view of a welding gun handle and housing showing our new design, the broken lines are for illustrative purposes only and form no part of the claimed design;

FIG. 2 is a left side elevational view thereof;

FIG. 3 is a front elevational view thereof;

FIG. 4 is a back elevational view thereof;

FIG. 5 is a top view thereof;

FIG. 6 is a bottom view thereof; and,

FIG. 7 is a perspective view thereof.

1 Claim, 5 Drawing Sheets

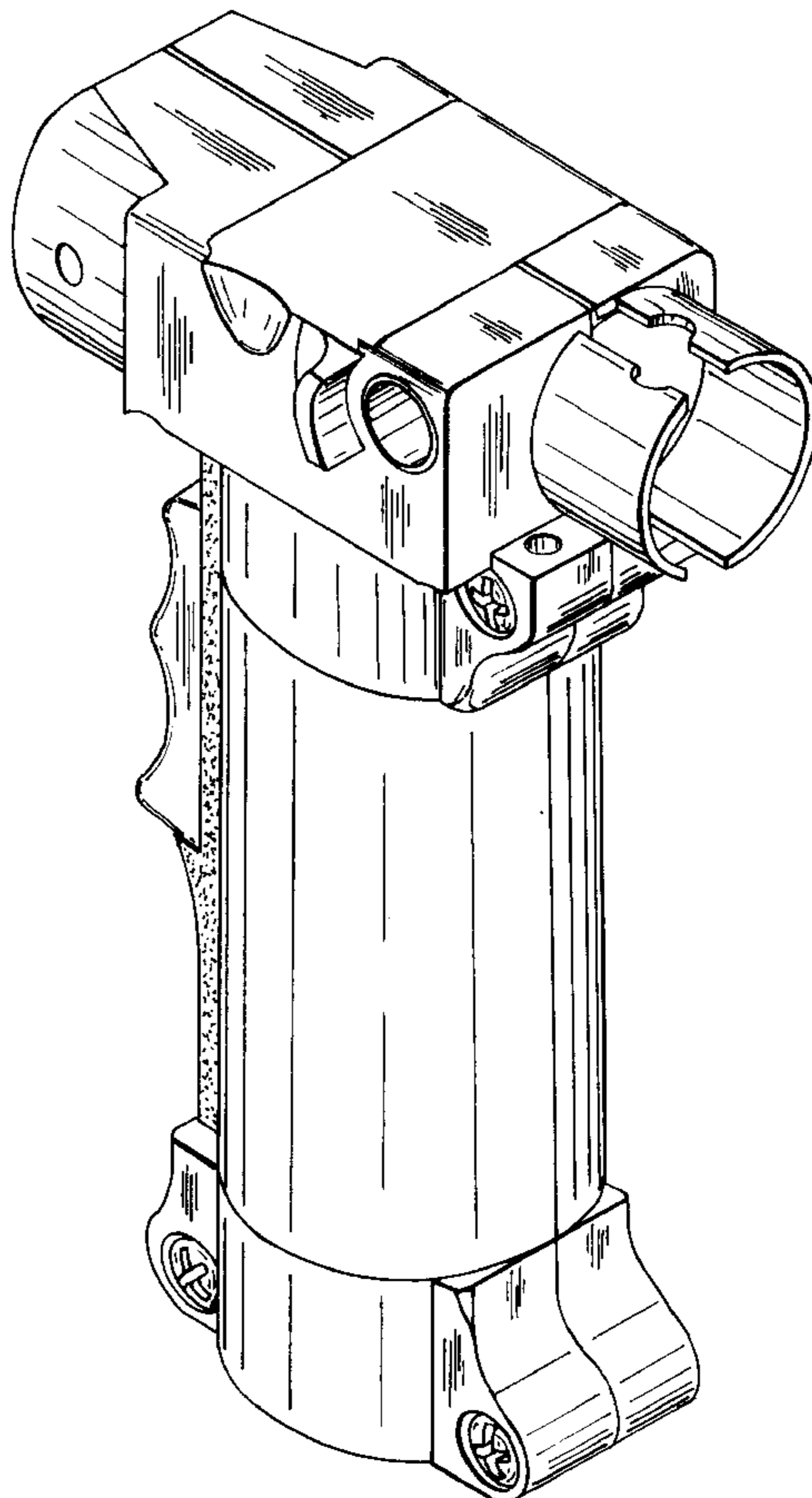

FIG. 1

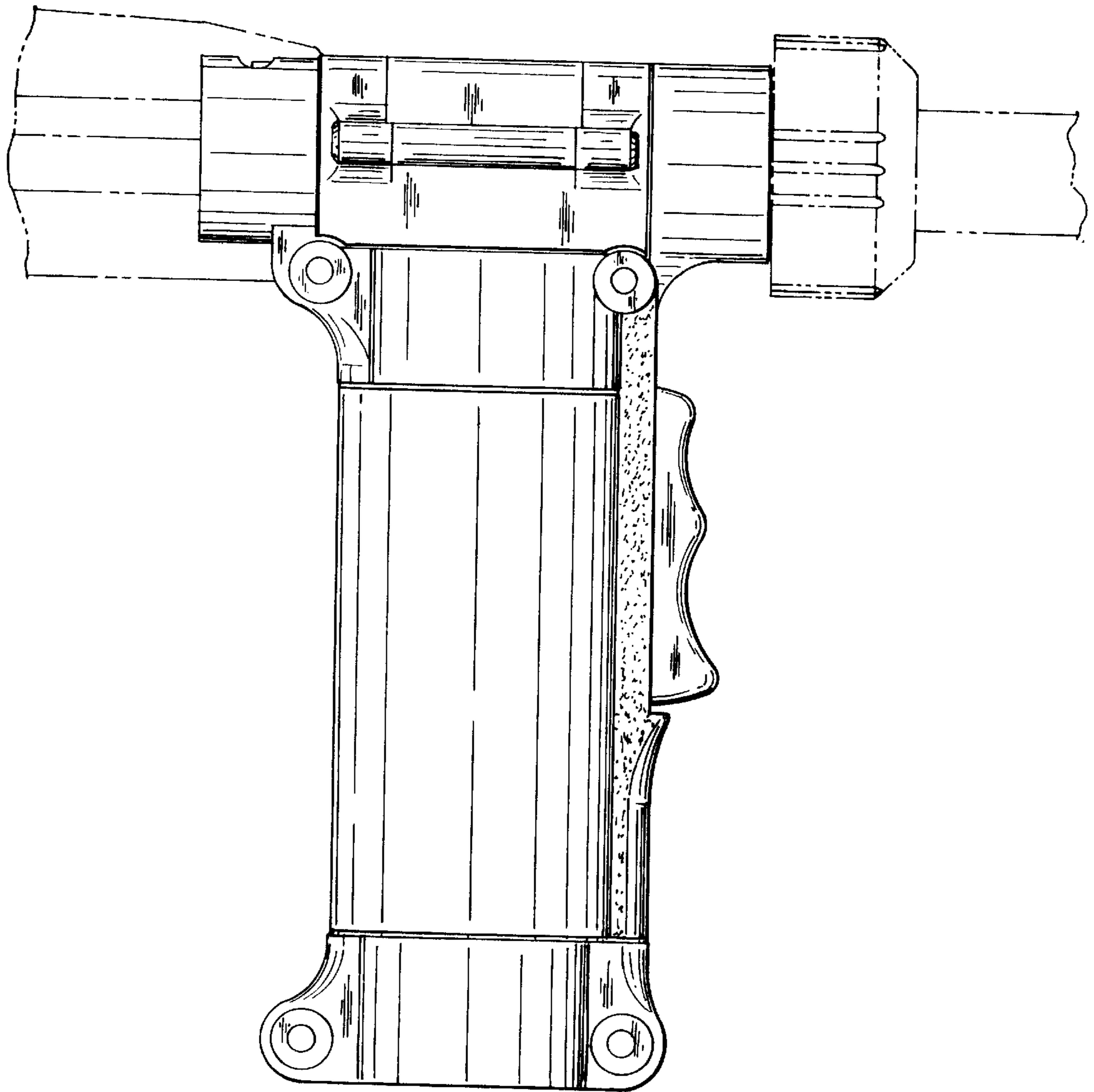

FIG. 2

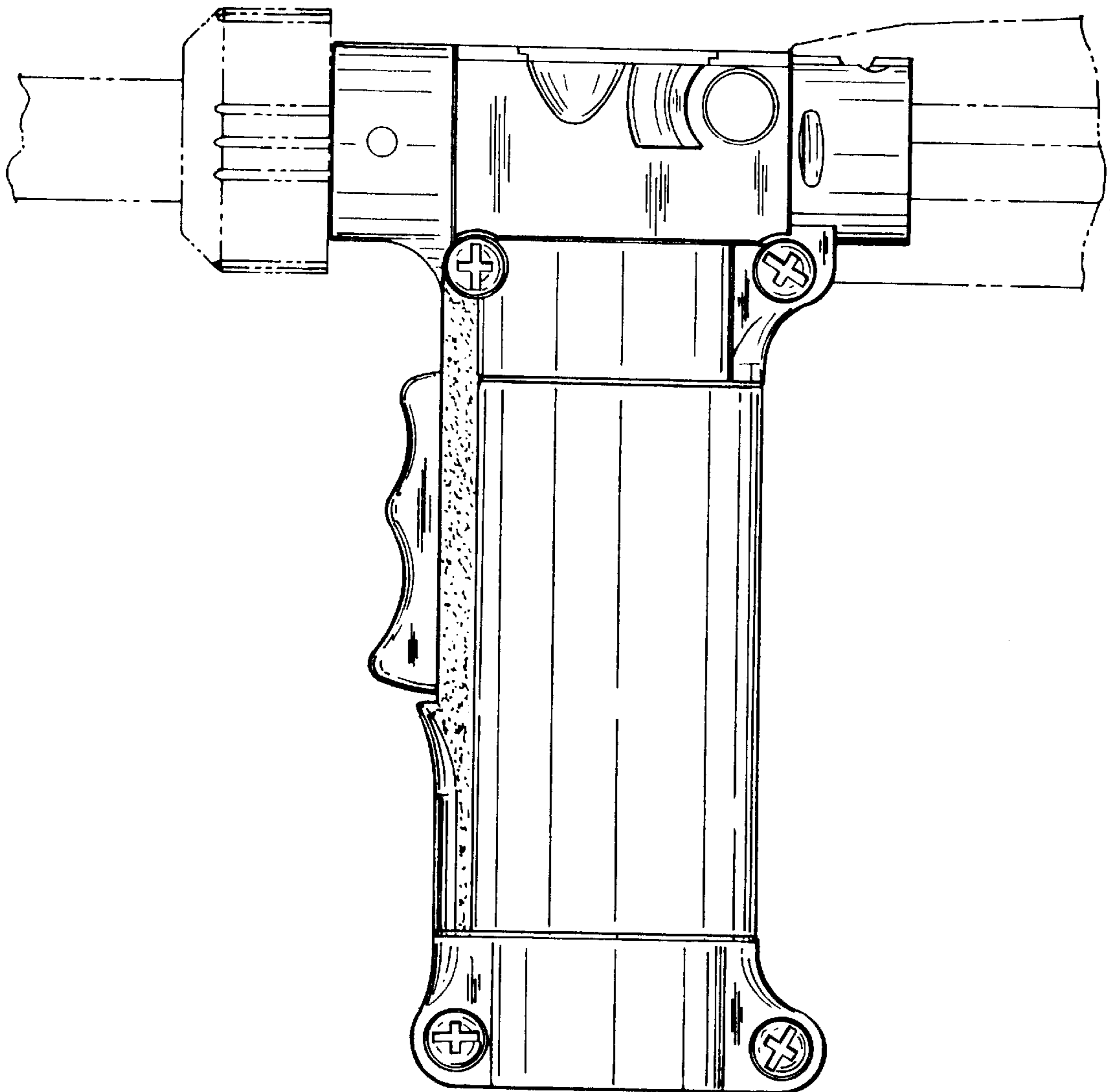

FIG. 3

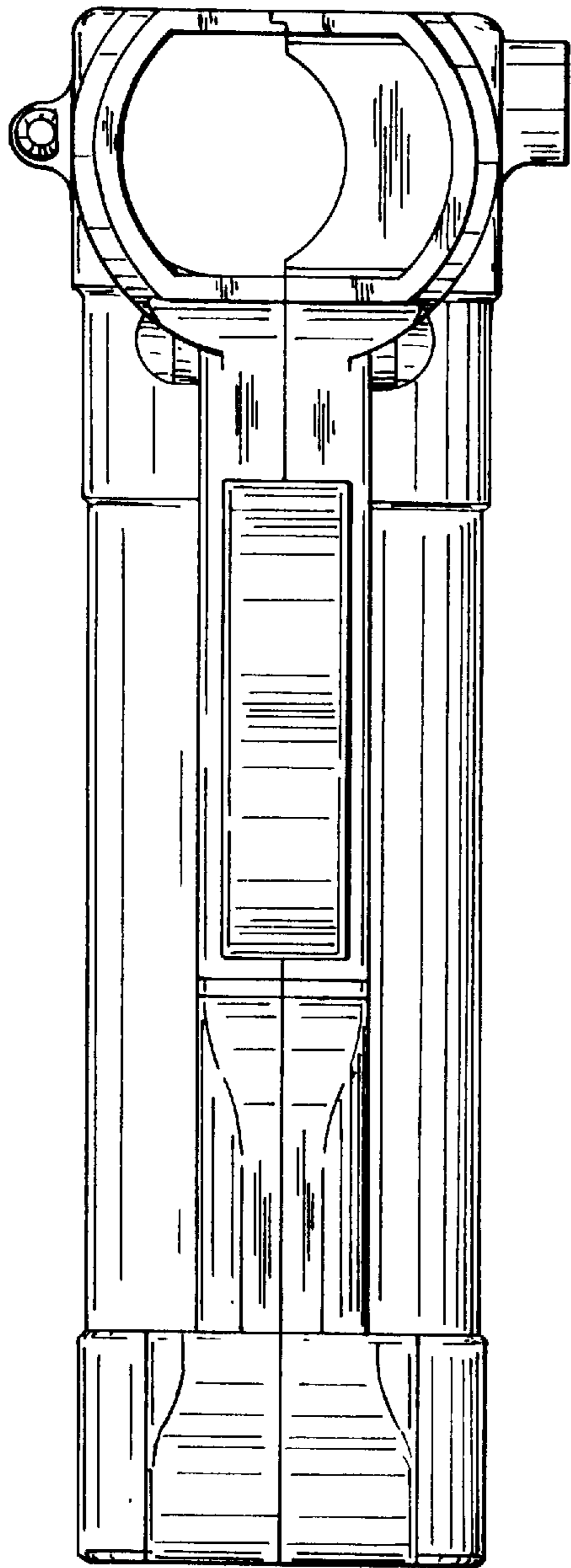

FIG. 4

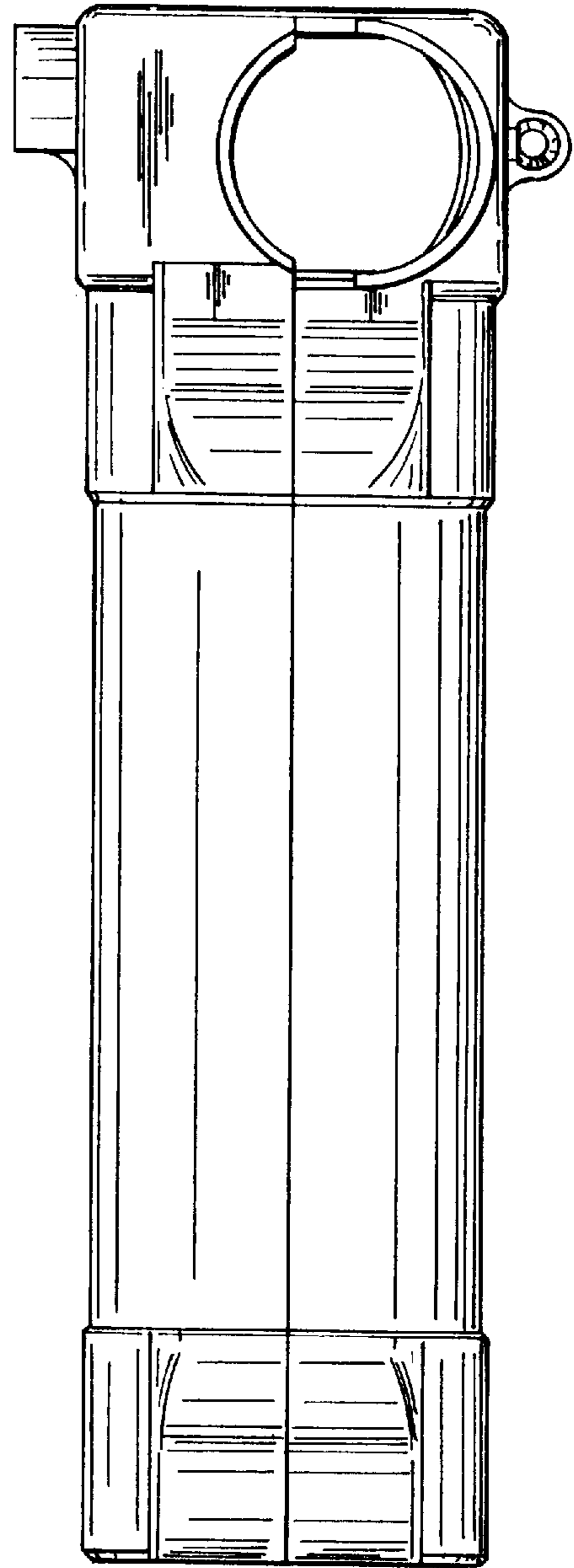

FIG. 5

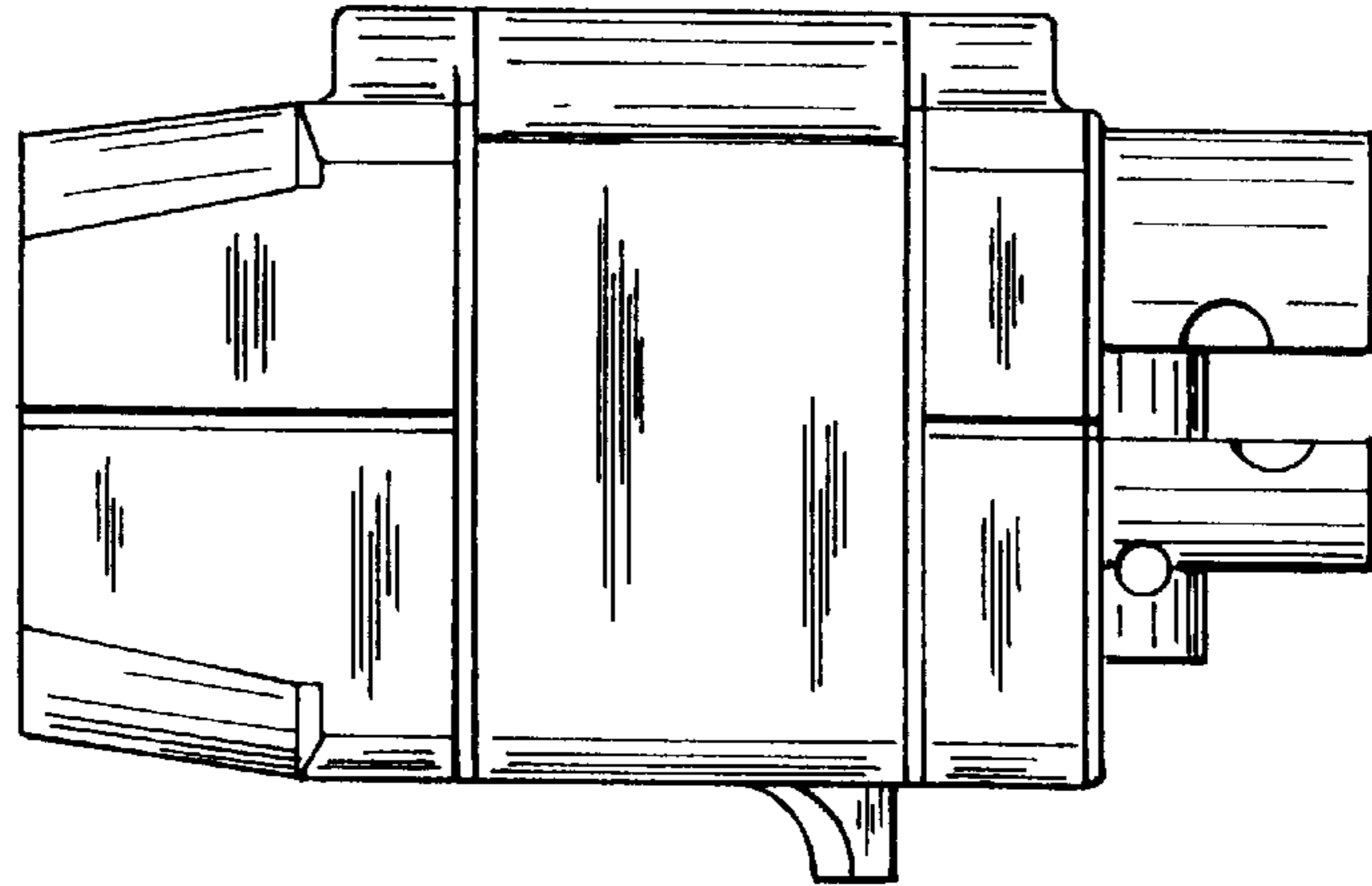

FIG. 6

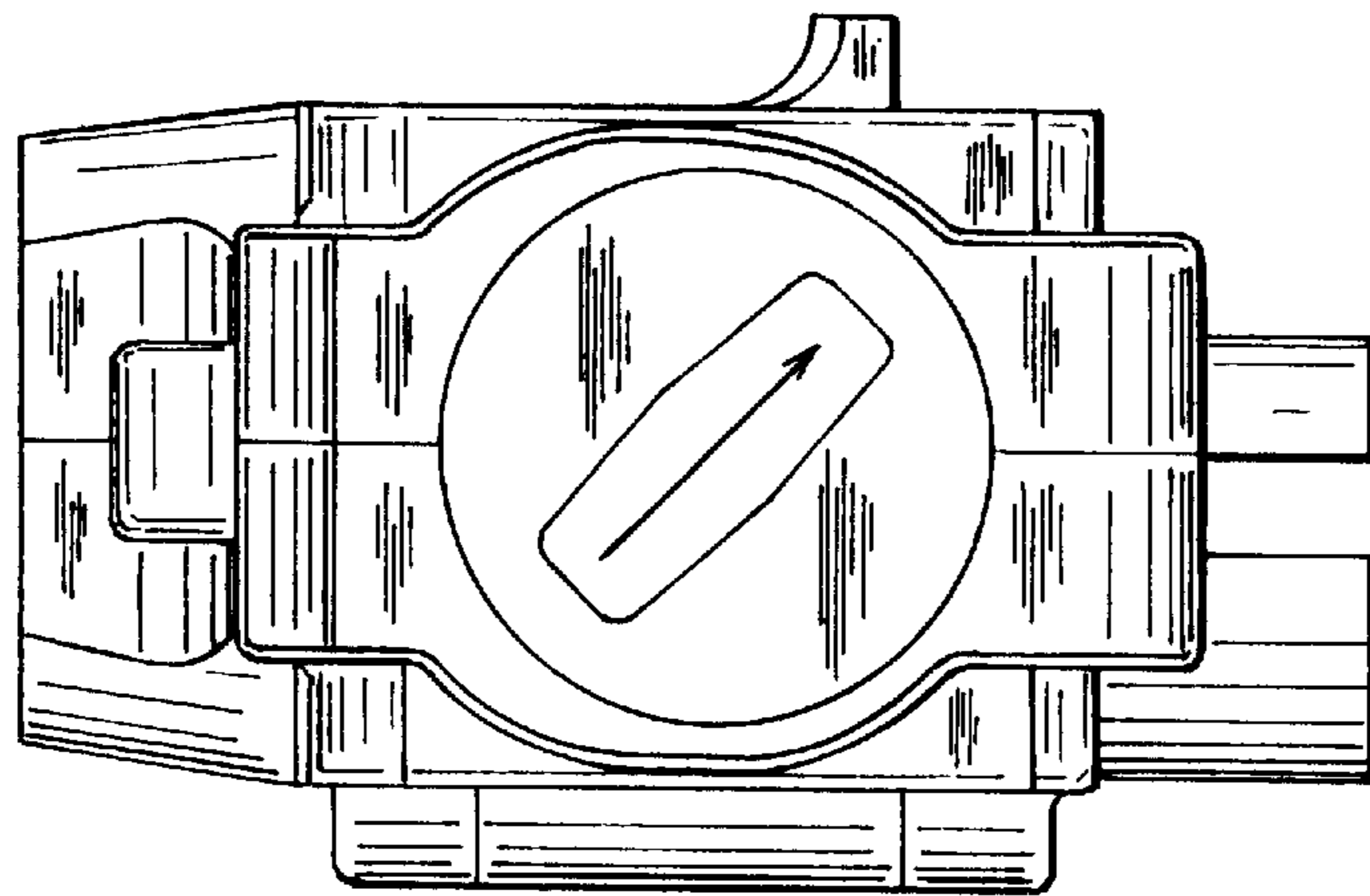

FIG. 7

