



US00D403139S

# United States Patent [19] Hunter

[11] Patent Number: Des. 403,139

[45] Date of Patent: \*\*Dec. 29, 1998

[54] NOVELTY CAP

5,510,961 4/1996 Peng .

[76] Inventor: James Dayle Hunter, 2110 Adamsville Rd., Zanesville, Ohio 43701

### FOREIGN PATENT DOCUMENTS

2268043 1/1994 United Kingdom .  
WO 92/20247 11/1992 WIPO .

[\*\*] Term: 14 Years

Primary Examiner—Paula A. Mortimer  
Attorney, Agent, or Firm—Richard C. Litman

[21] Appl. No.: 78,842

[22] Filed: Nov. 4, 1997

### [57] CLAIM

[51] LOC (6) Cl. .... 02-03

The ornamental design for a novelty cap, as shown and described.

[52] U.S. Cl. .... D2/866; D2/882

[58] Field of Search ..... D2/865, 866, 882,  
D2/891; 2/195.1, 195.6, 209.13; 362/105,  
106; 24/10 R; 248/74.1, 74.2; D8/395

### DESCRIPTION

### [56] References Cited

#### U.S. PATENT DOCUMENTS

D. 160,404	10/1950	Levine .	
D. 297,584	9/1988	Lenox et al. .	
D. 390,101	2/1998	Nygards .....	D8/395
2,169,067	8/1939	Dorsey .....	D2/891 X
2,718,010	9/1955	Giraham .....	2/195.6
3,313,009	4/1967	Beckerer .....	248/74.2
4,586,280	5/1986	Dane .	
4,839,926	6/1989	Choi .	
4,998,187	3/1991	Herrick .....	362/106
5,199,780	4/1993	Ekman .	
5,386,592	2/1995	Checkeroski .....	2/209.13
5,462,471	10/1995	Power-Fardy .	

FIG. 1 is a perspective view of a novelty cap showing my new design;  
FIG. 2 is a top plan view of a novelty cap showing my new design;  
FIG. 3 is a front elevational view thereof;  
FIG. 4 is a right side elevational view with the left side being a mirror image thereof;  
FIG. 5 is a rear elevational view thereof;  
FIG. 6 is a bottom plan view thereof; and,  
FIG. 7 is an environmental perspective view thereof.  
The broken line showing of the car in FIG. 7 is for illustrative purposes only and forms no part of the claimed design.

1 Claim, 5 Drawing Sheets

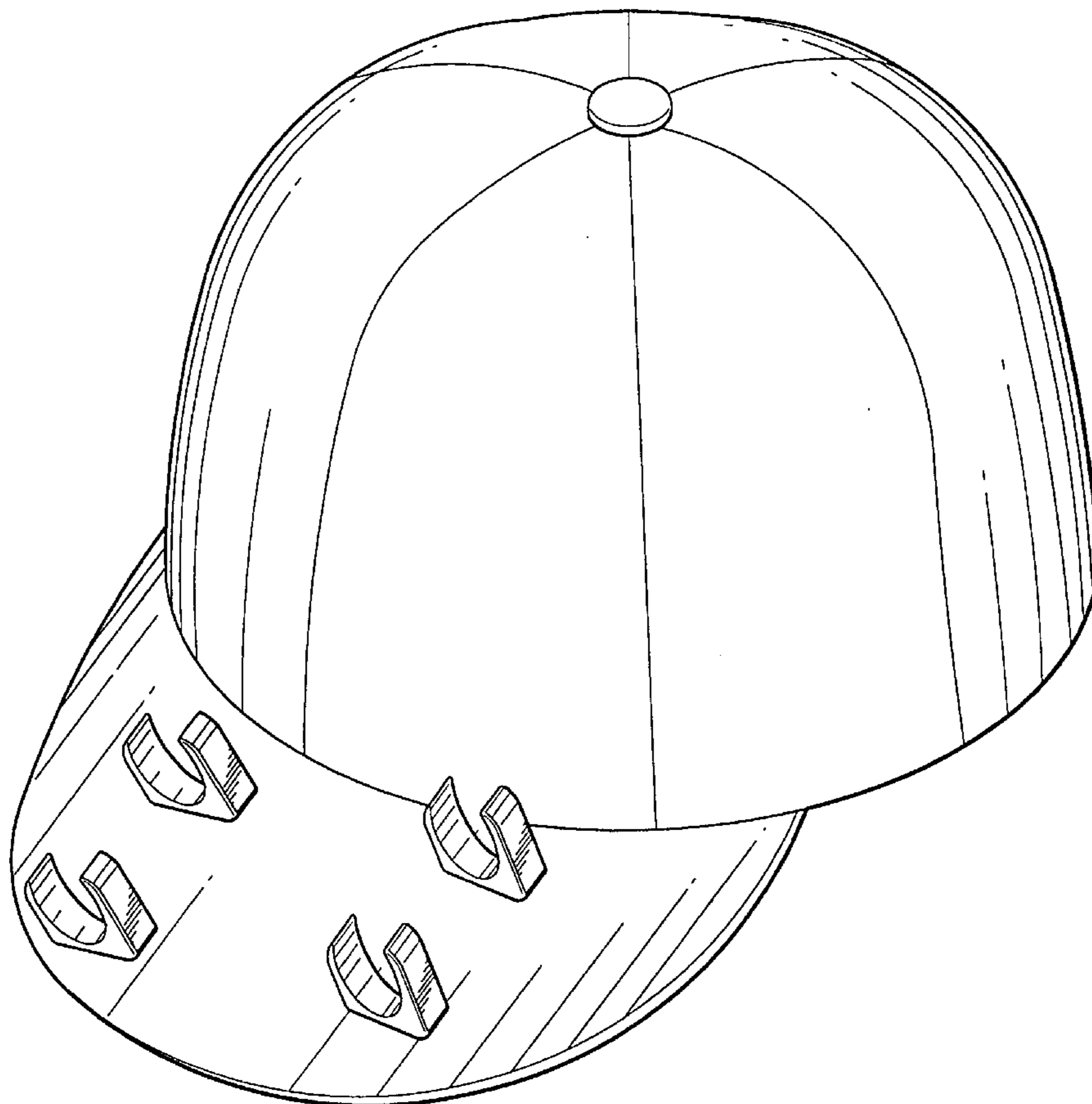

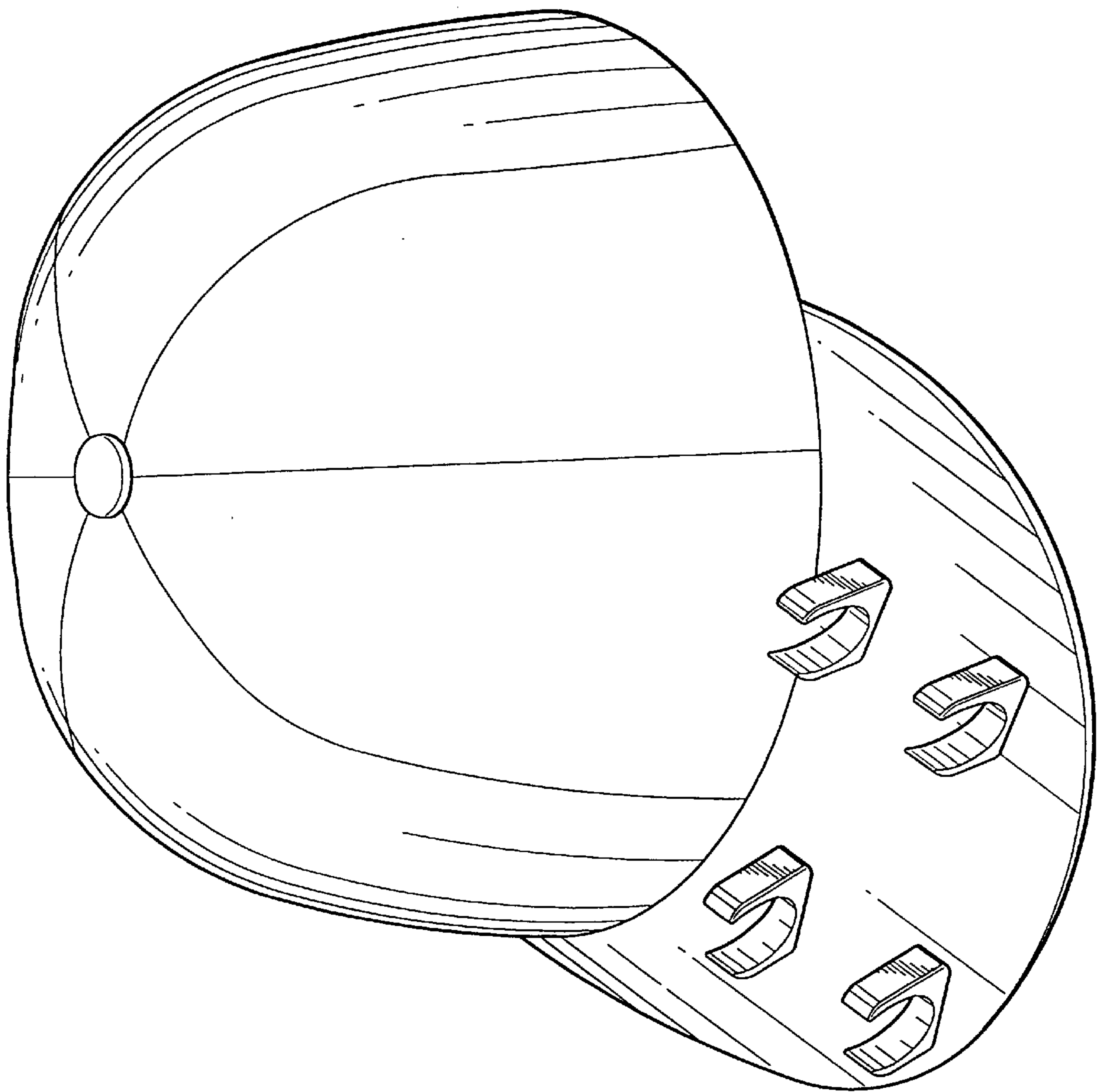

FIG. 1

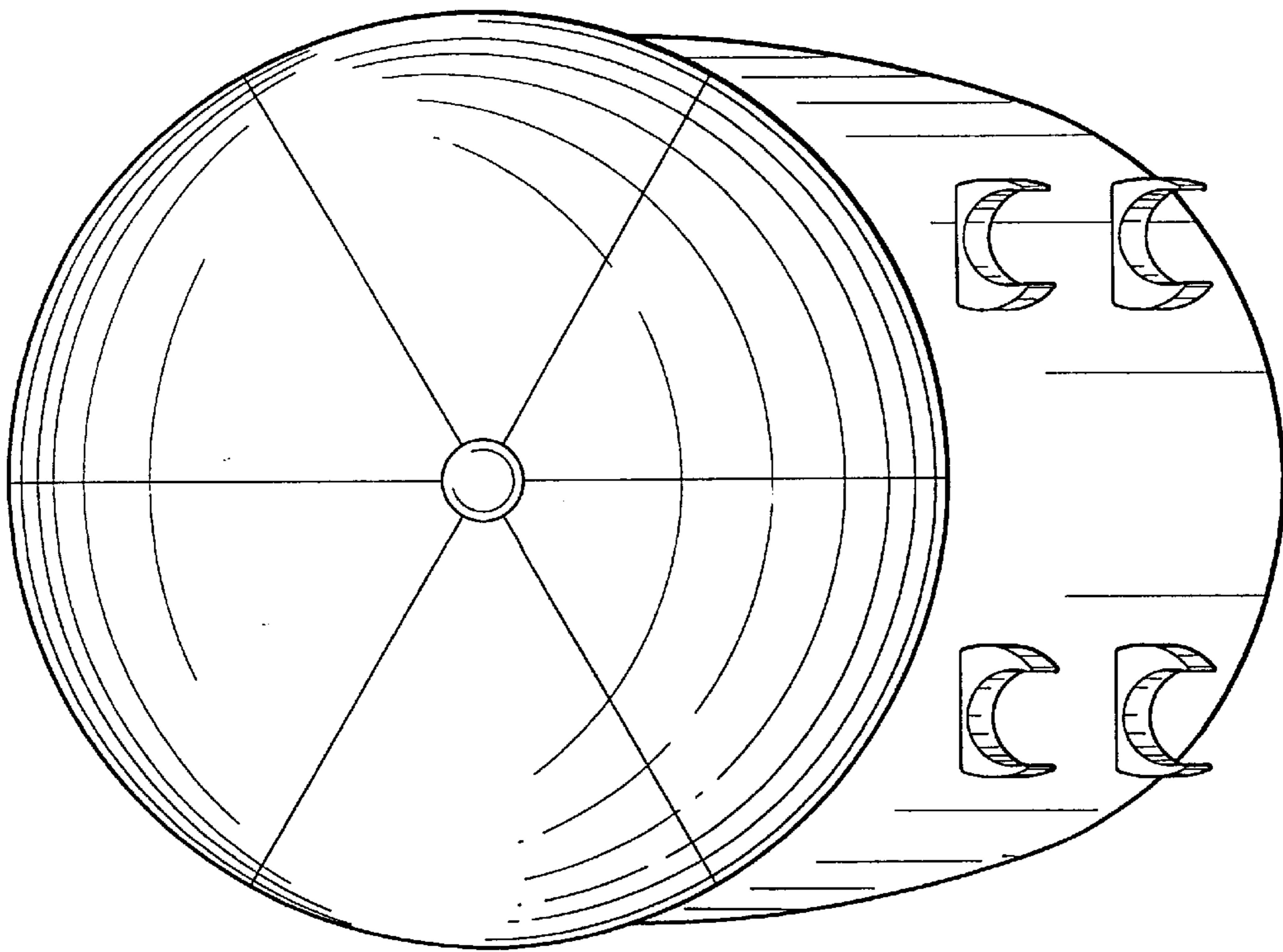

FIG. 2

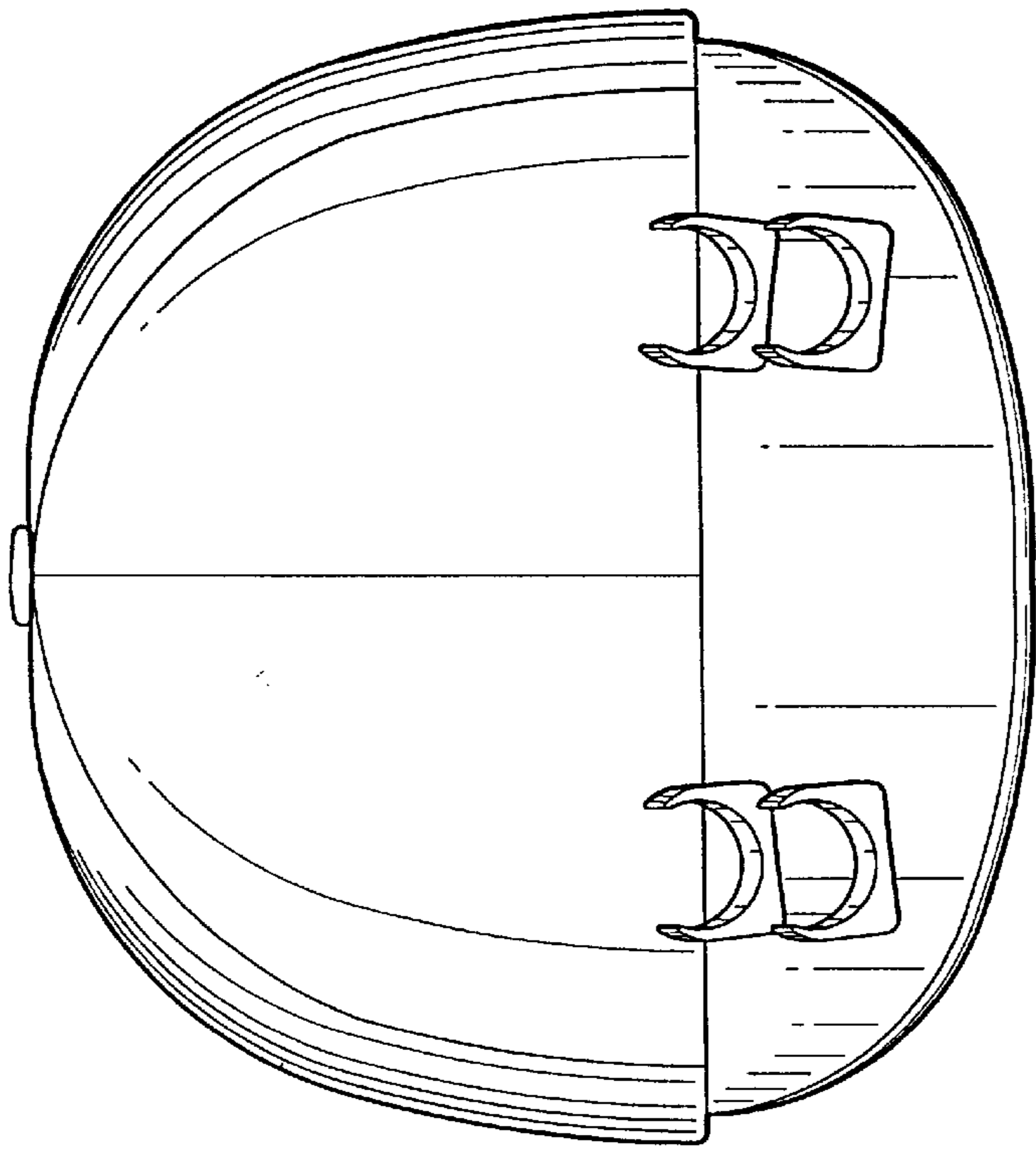

FIG. 3

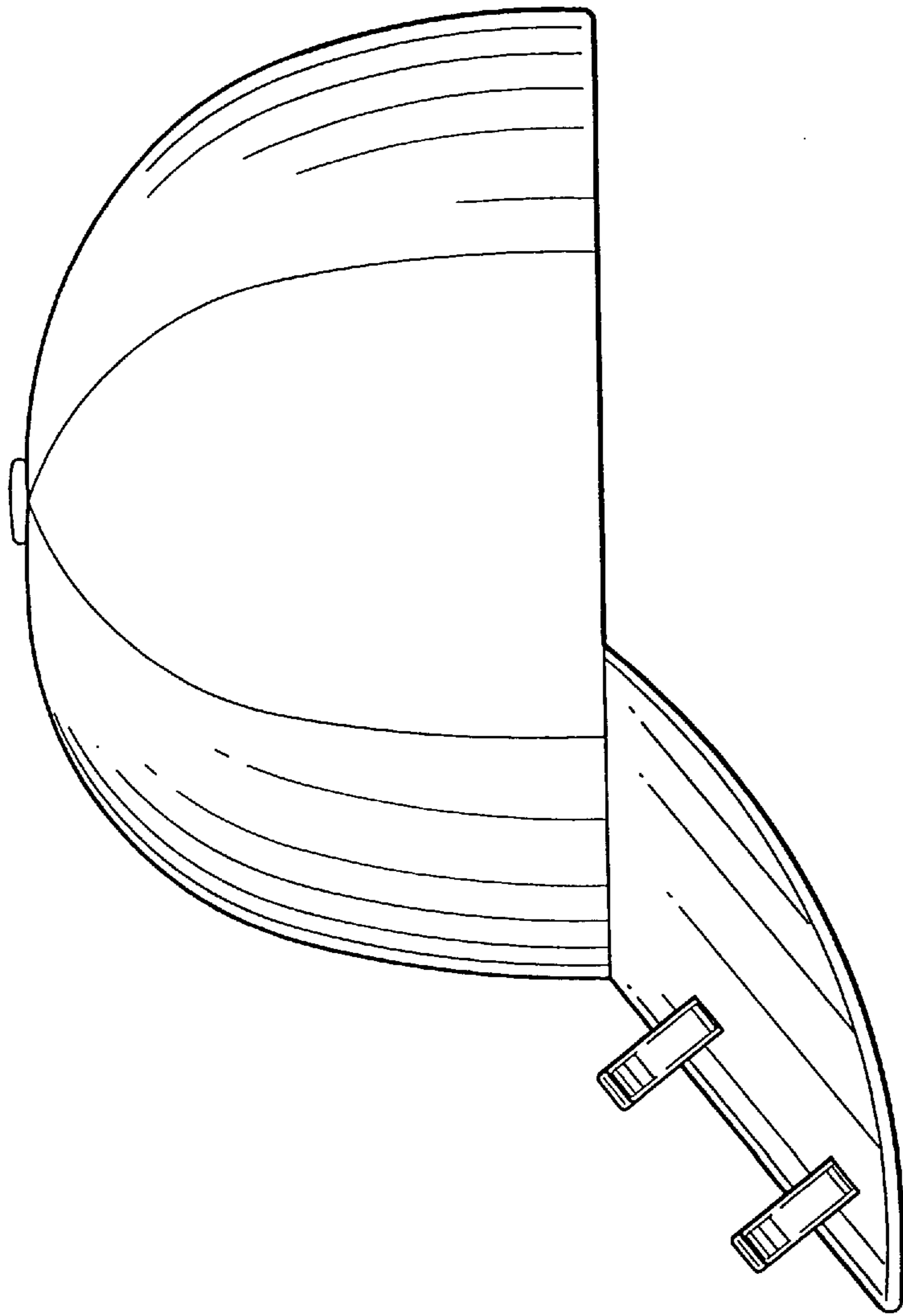

FIG. 4

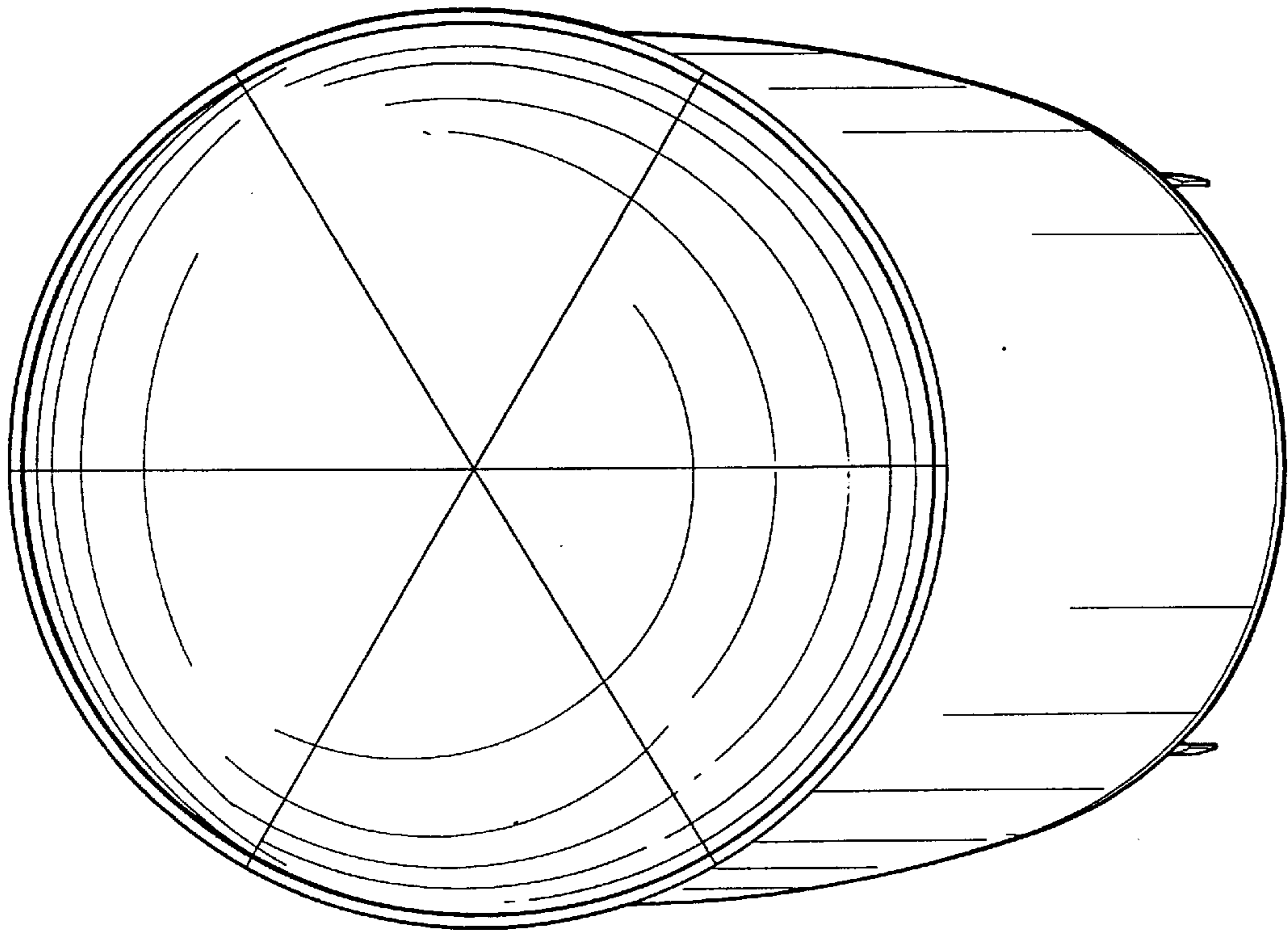

FIG. 6

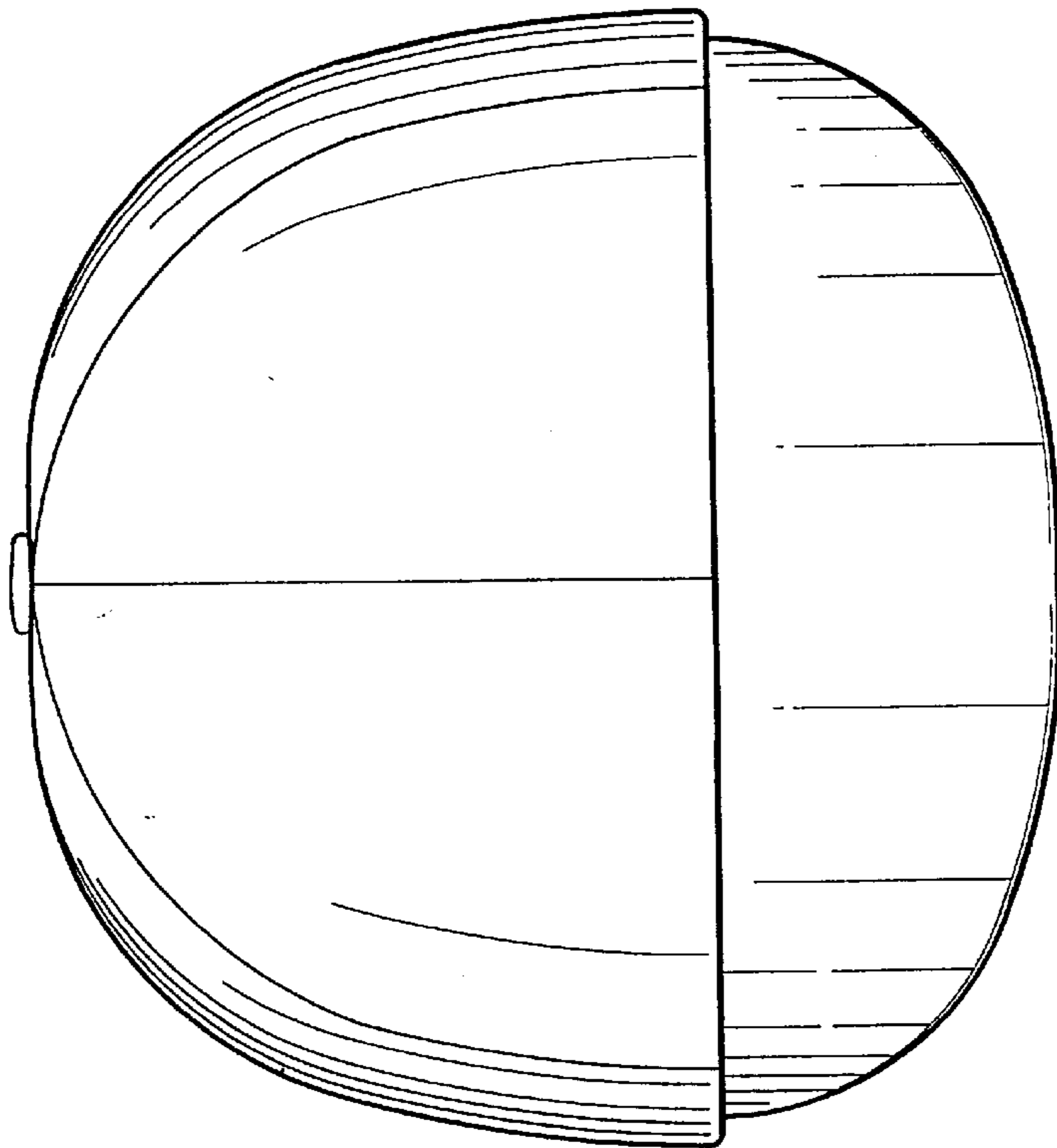

FIG. 5

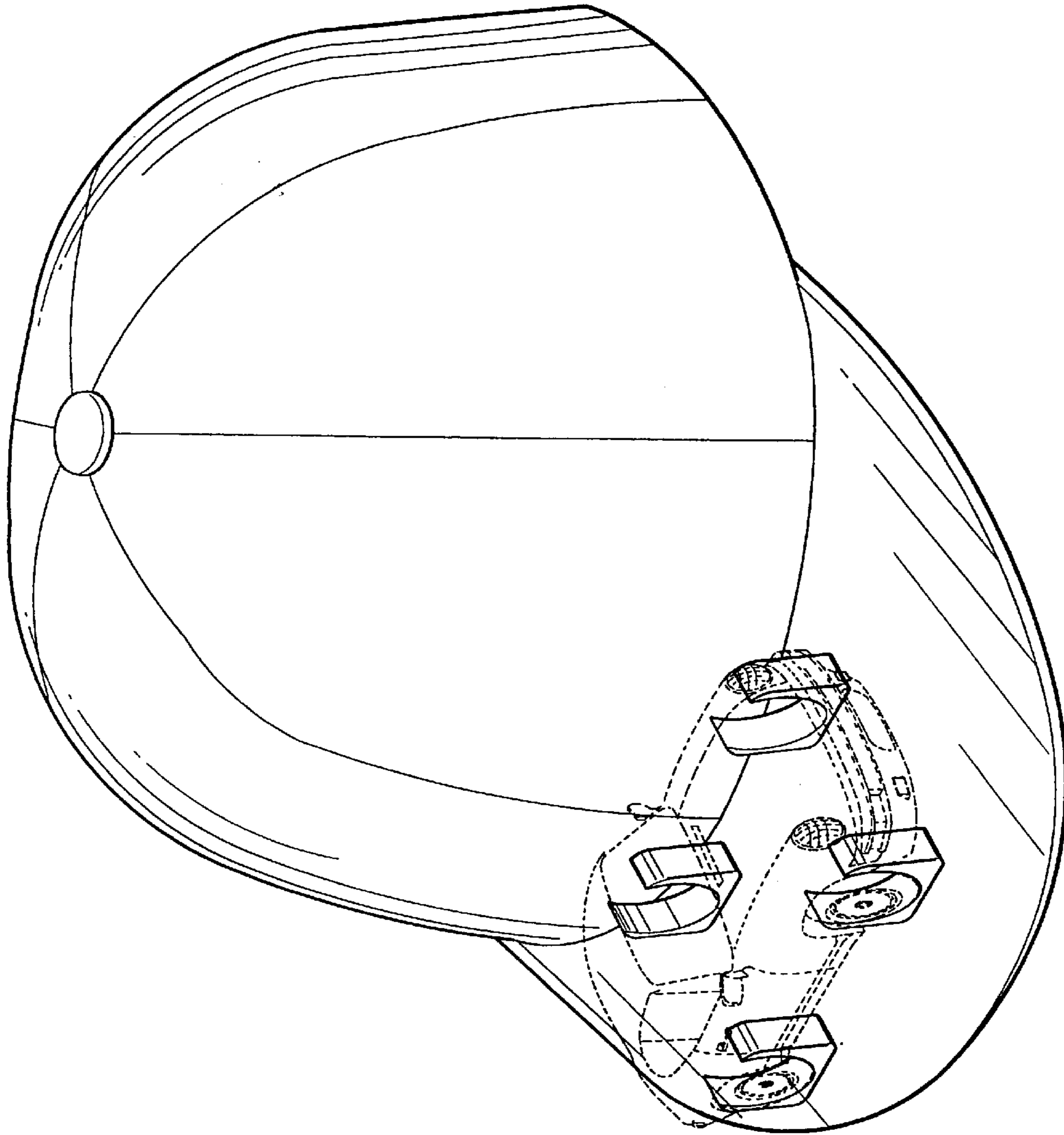

FIG. 7