



US00D403035S

**United States Patent** [19]  
**MacPherson**

[11] **Patent Number: Des. 403,035**

[45] **Date of Patent: \*\*Dec. 22, 1998**

[54] **HAND EXERCISING GRIP FOR STEERING WHEEL**

**DESCRIPTION**

[76] Inventor: **William James MacPherson**, P.O. Box 535, Campbellton, New Brunswick, Canada, E3N 3G9

[\*\*] Term: **14 Years**

[21] Appl. No.: **73,733**

[22] Filed: **Jul. 21, 1997**

[51] **LOC (6) Cl.** ..... **21-02**

[52] **U.S. Cl.** ..... **D8/303; D8/303**

[58] **Field of Search** ..... D21/191, 198; D8/107, 303, 307; 16/111 R; 81/489; 489/49, 121, 148, 44, 45

[56] **References Cited**

**U.S. PATENT DOCUMENTS**

D. 269,941	8/1983	Morgan	.....	D8/303
D. 300,506	4/1989	Pedone	.....	D8/303
D. 305,401	1/1990	Winston	.....	D8/303
D. 326,127	5/1992	Rink	.....	D21/198
D. 342,884	1/1994	Skroskis	.....	D8/303
4,890,335	1/1990	Schulten	.....	16/111 R
5,076,569	12/1991	Gootter	.....	482/49
5,155,878	10/1992	Dellis	.....	16/111 R
5,224,397	7/1993	Yoo	.....	74/558
5,681,243	10/1997	Criss	.....	482/49

*Primary Examiner*—Philip S. Hyder  
*Attorney, Agent, or Firm*—Mario D. Theriault

[57] **CLAIM**

The ornamental design for a hand exercising grip for steering wheel, as shown and described.

FIG. 1 is a front elevation view of a hand exercising grip for steering wheel showing my new design;

FIG. 2 is an enlarged rear and left side perspective view thereof;

FIG. 3 is an enlarged front and top perspective view thereof;

FIG. 4 is an enlarged front elevation view thereof;

FIG. 5 is a left side elevation view thereof;

FIG. 6 is a right side elevation view thereof;

FIG. 7 is a top view thereof;

FIG. 8 is a bottom view thereof;

FIG. 9 is a front elevation view of a modified embodiment thereof;

FIG. 10 is an enlarged rear and right side perspective view of the modified embodiment thereof;

FIG. 11 is an enlarged front and top perspective view of the modified embodiment thereof;

FIG. 12 is an enlarged front elevation view of the modified embodiment thereof;

FIG. 13 is a left side elevation view of the modified embodiment thereof;

FIG. 14 is a right side elevation view of the modified embodiment thereof;

FIG. 15 is a top view of the modified embodiment thereof; and,

FIG. 16 is a bottom view of the modified embodiment thereof.

The broken line showings of the steering wheel in FIGS. 1 and 9 are for illustrative purposes only and form no part of the claimed design.

**1 Claim, 4 Drawing Sheets**

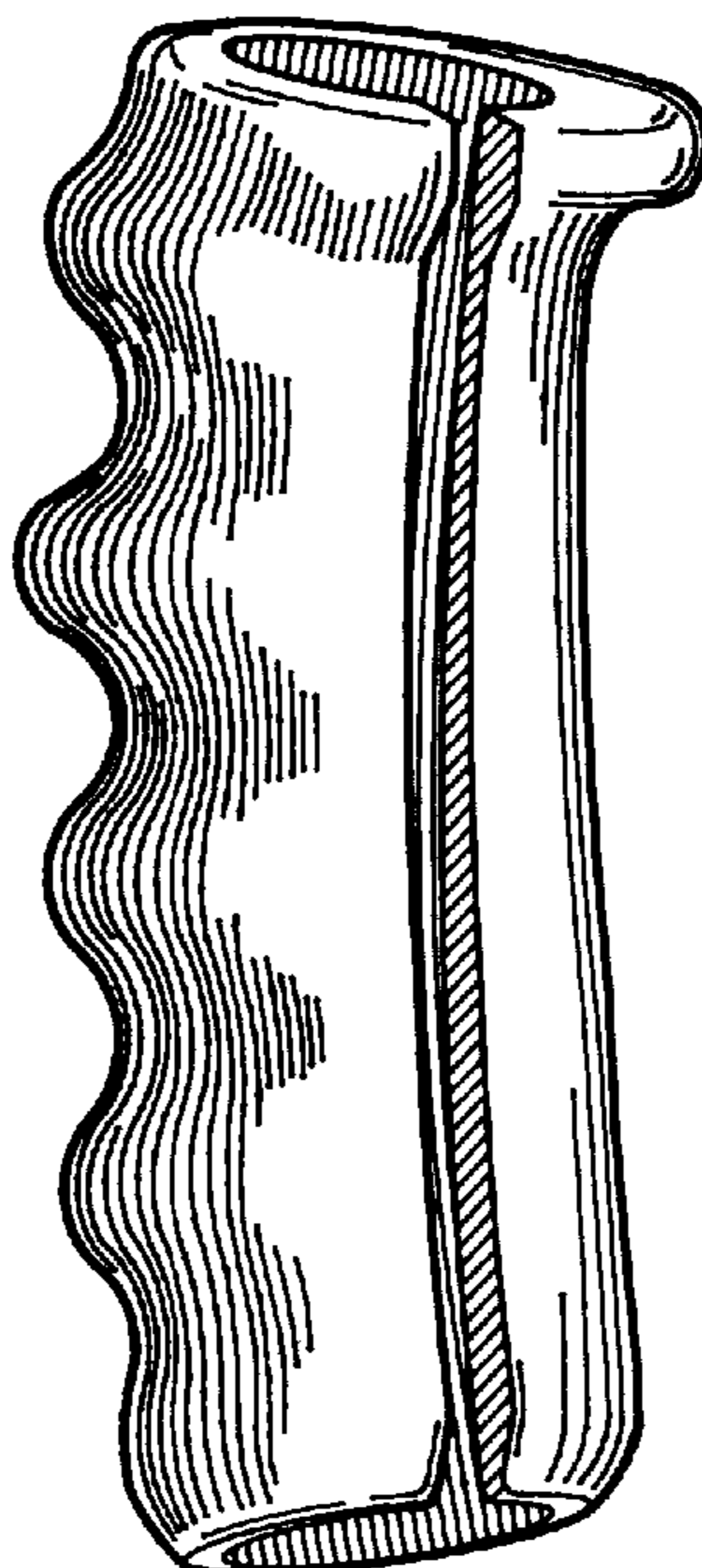

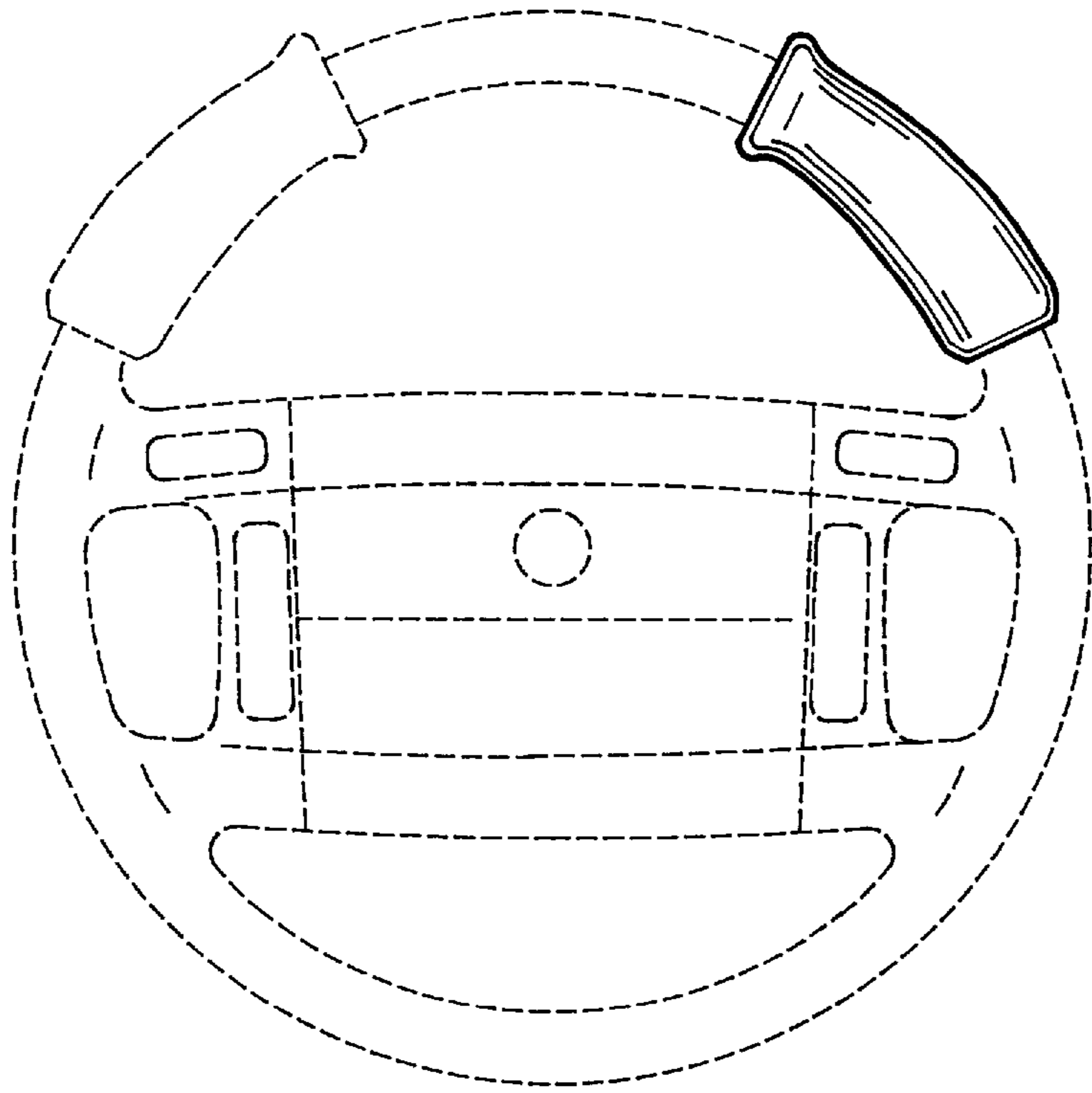

FIG. 1

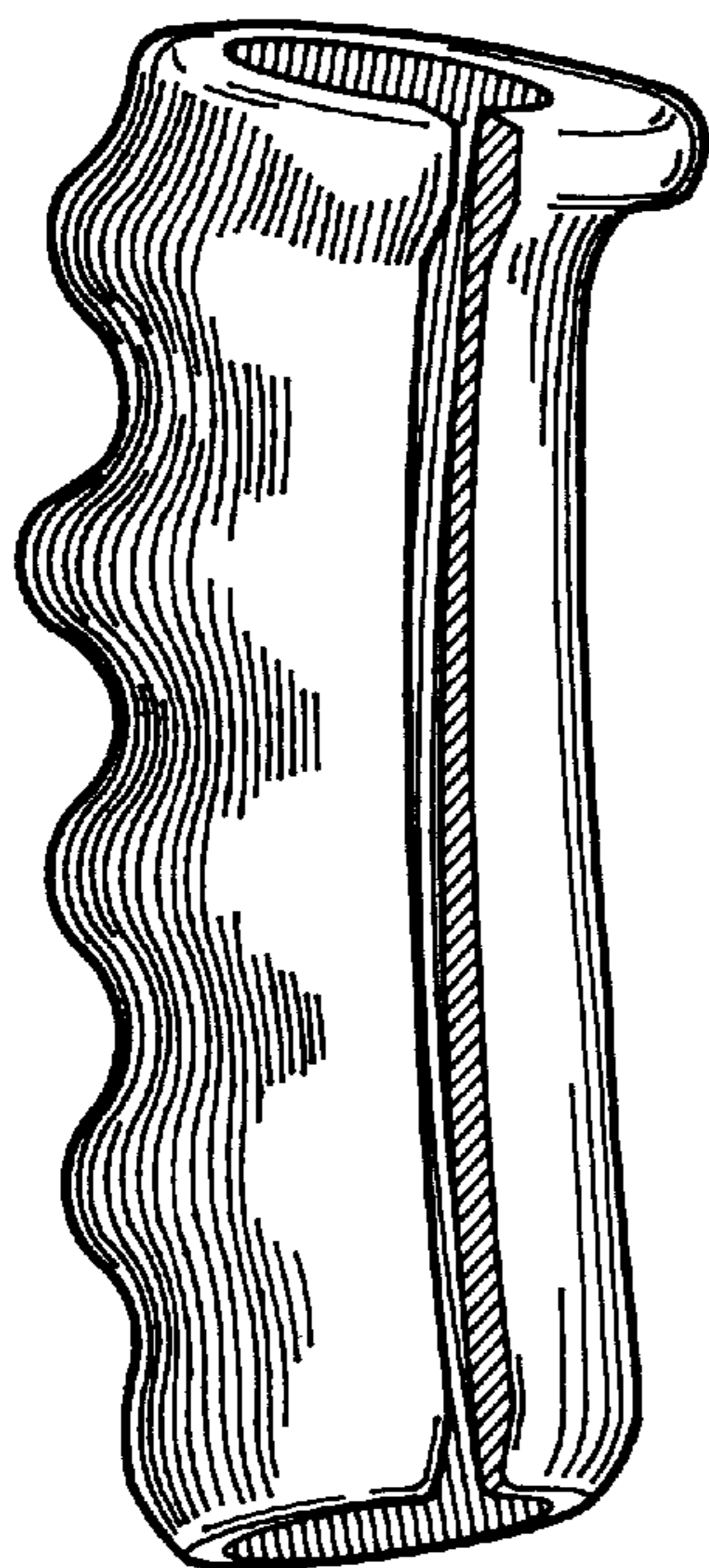

FIG. 2

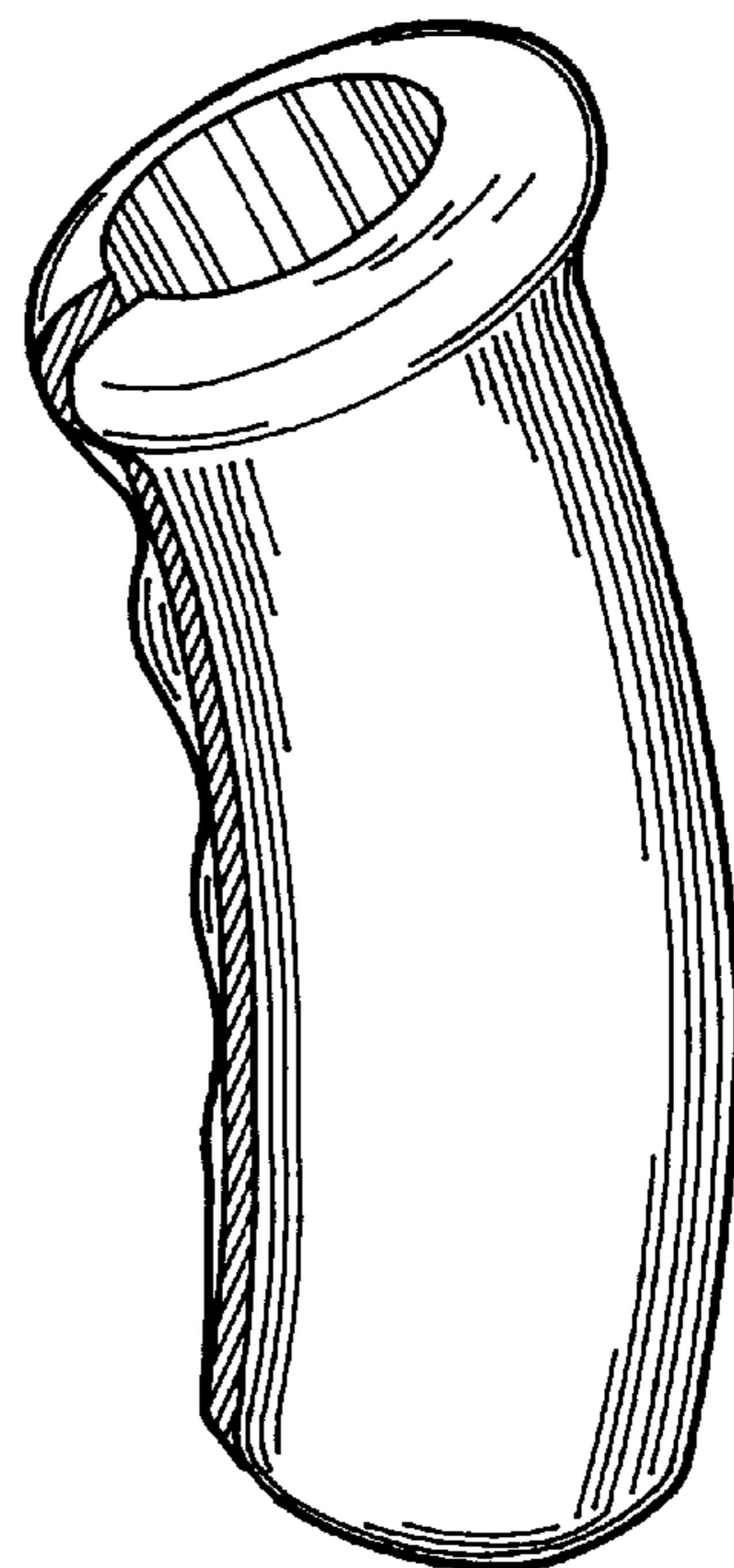

FIG. 3

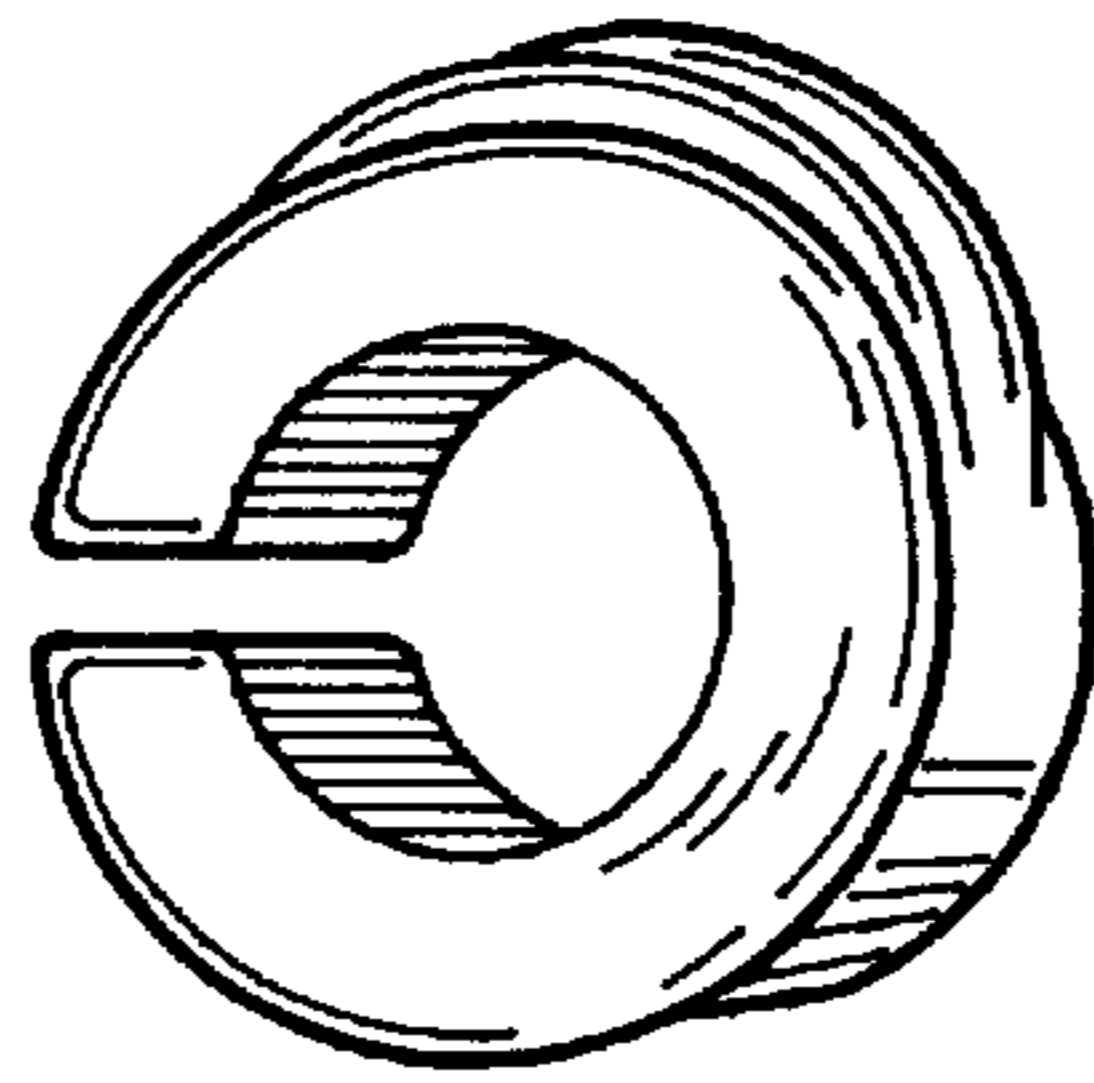

FIG. 7

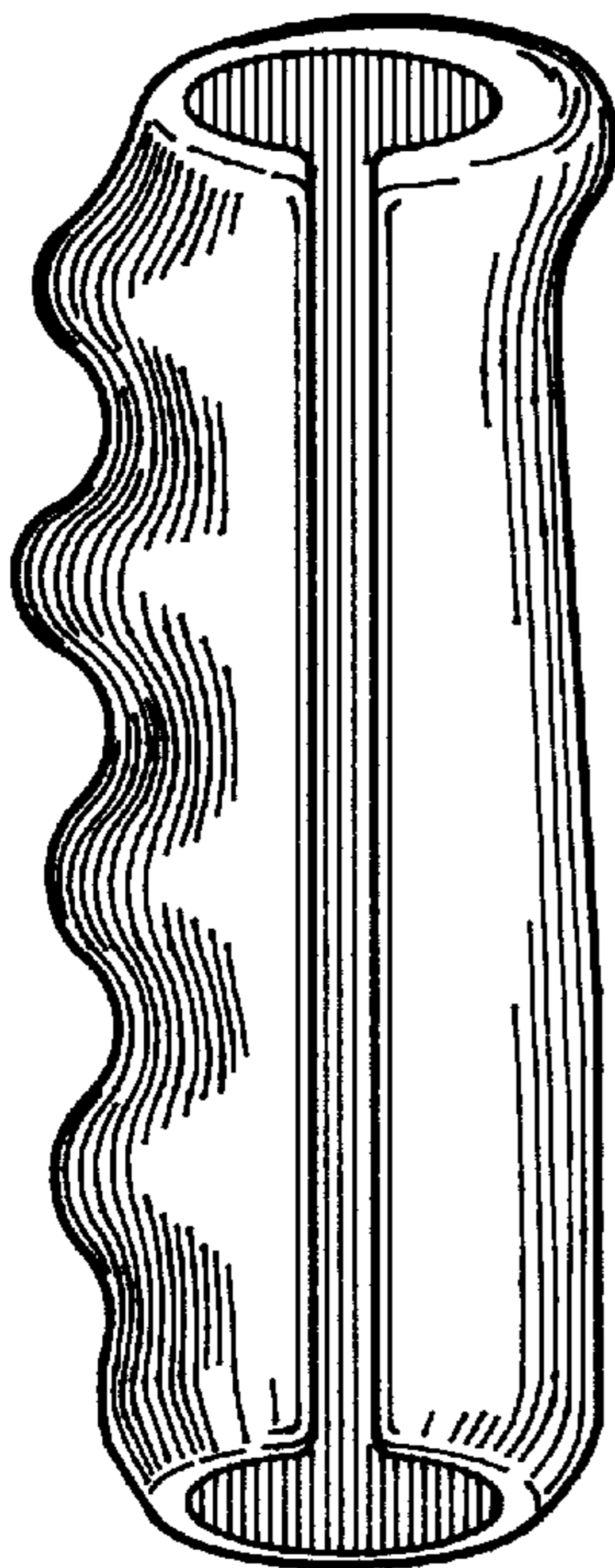

FIG. 5



FIG. 4

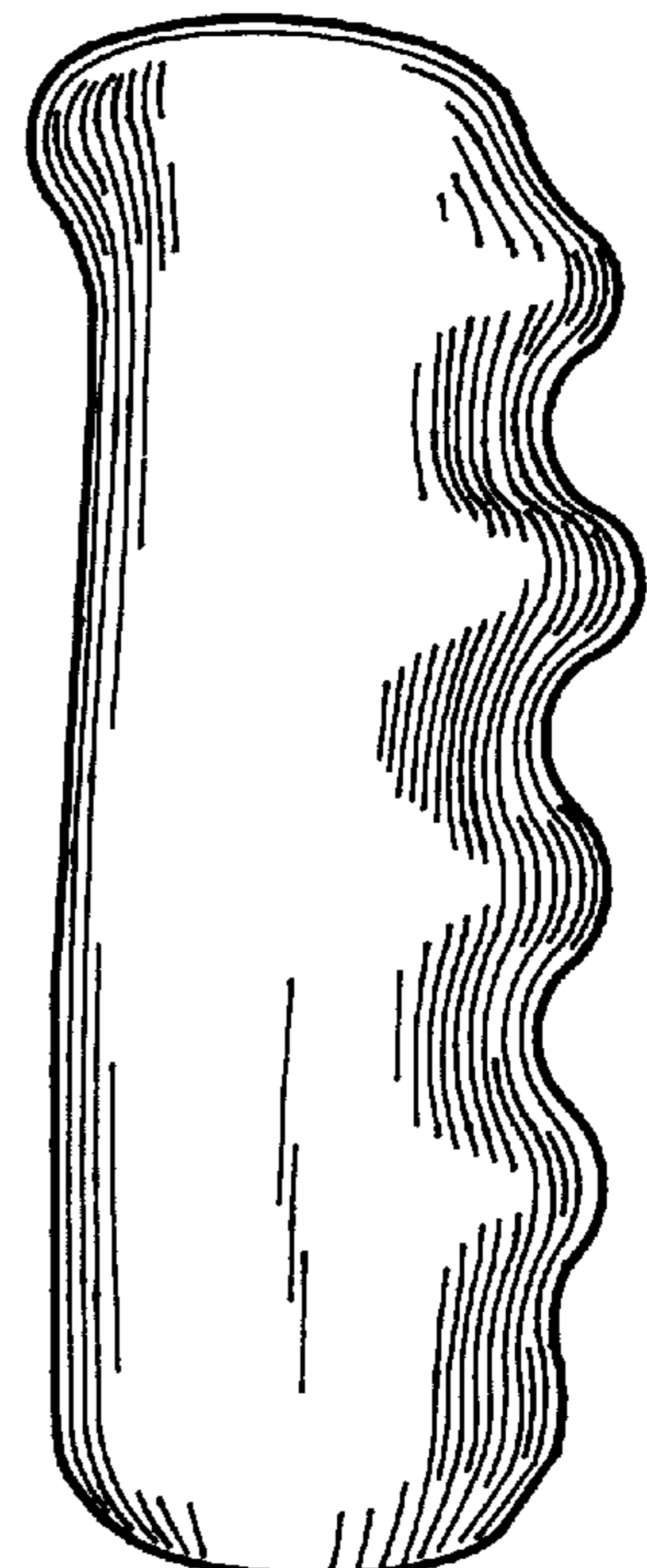

FIG. 6

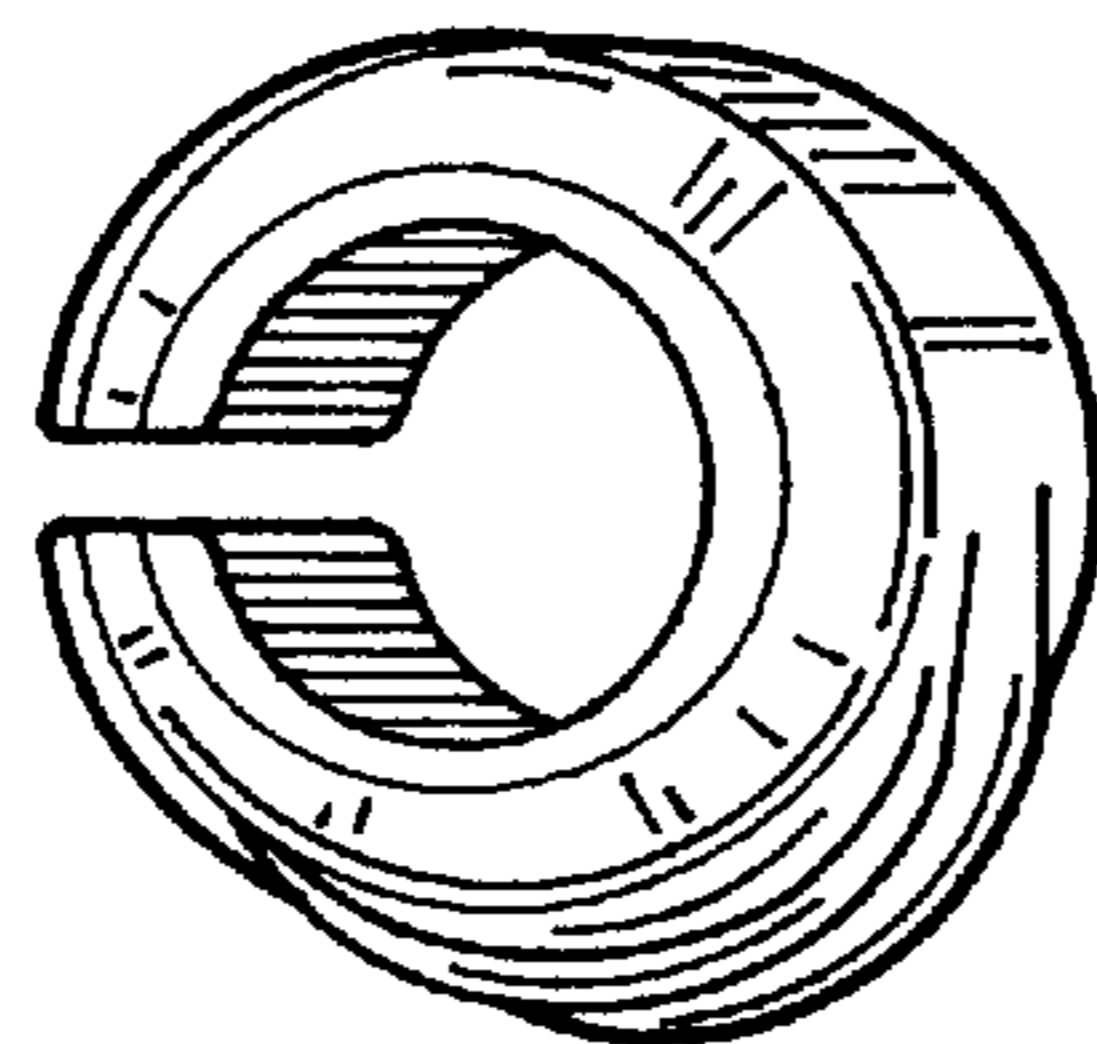

FIG. 8

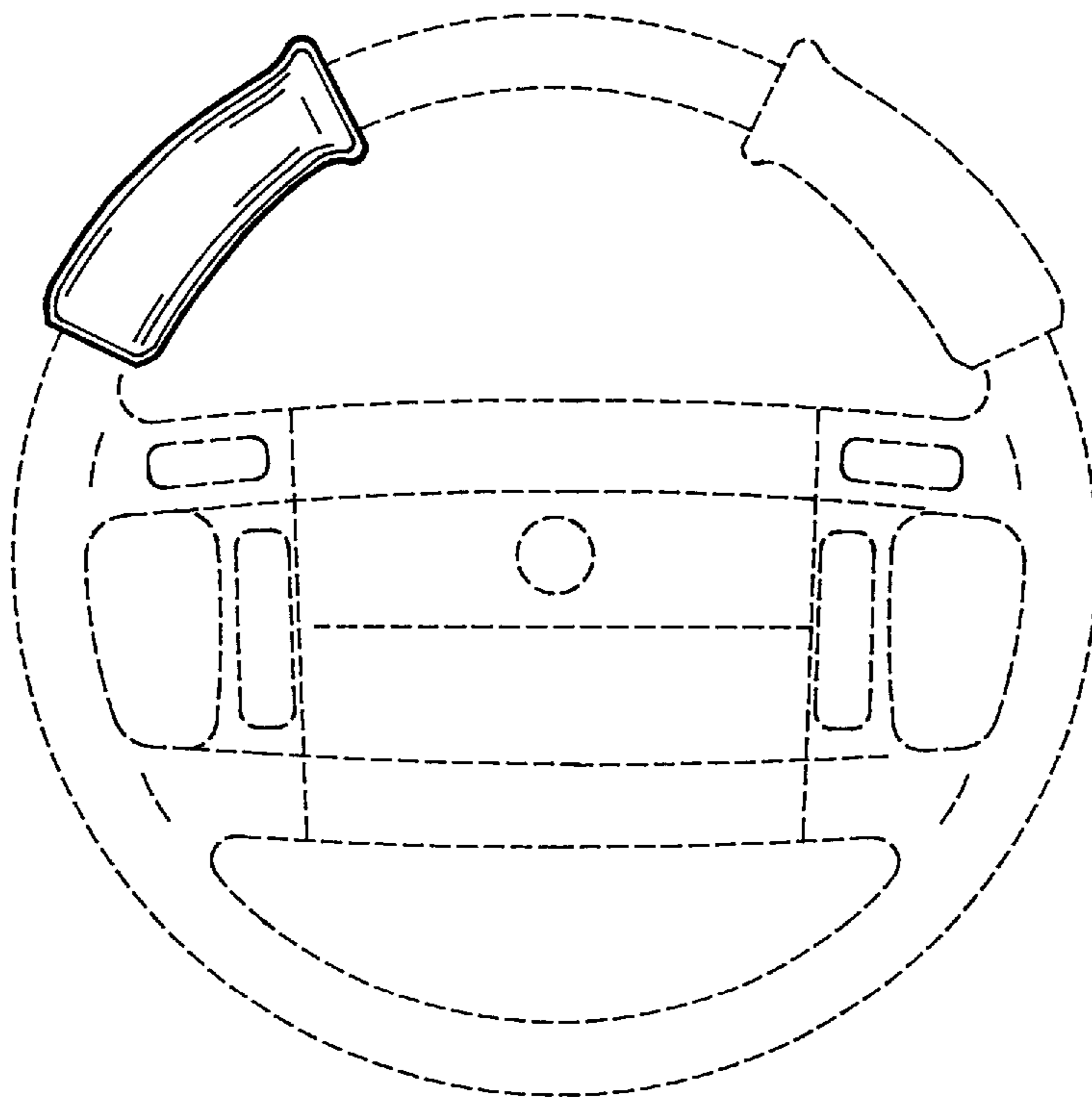

FIG. 9

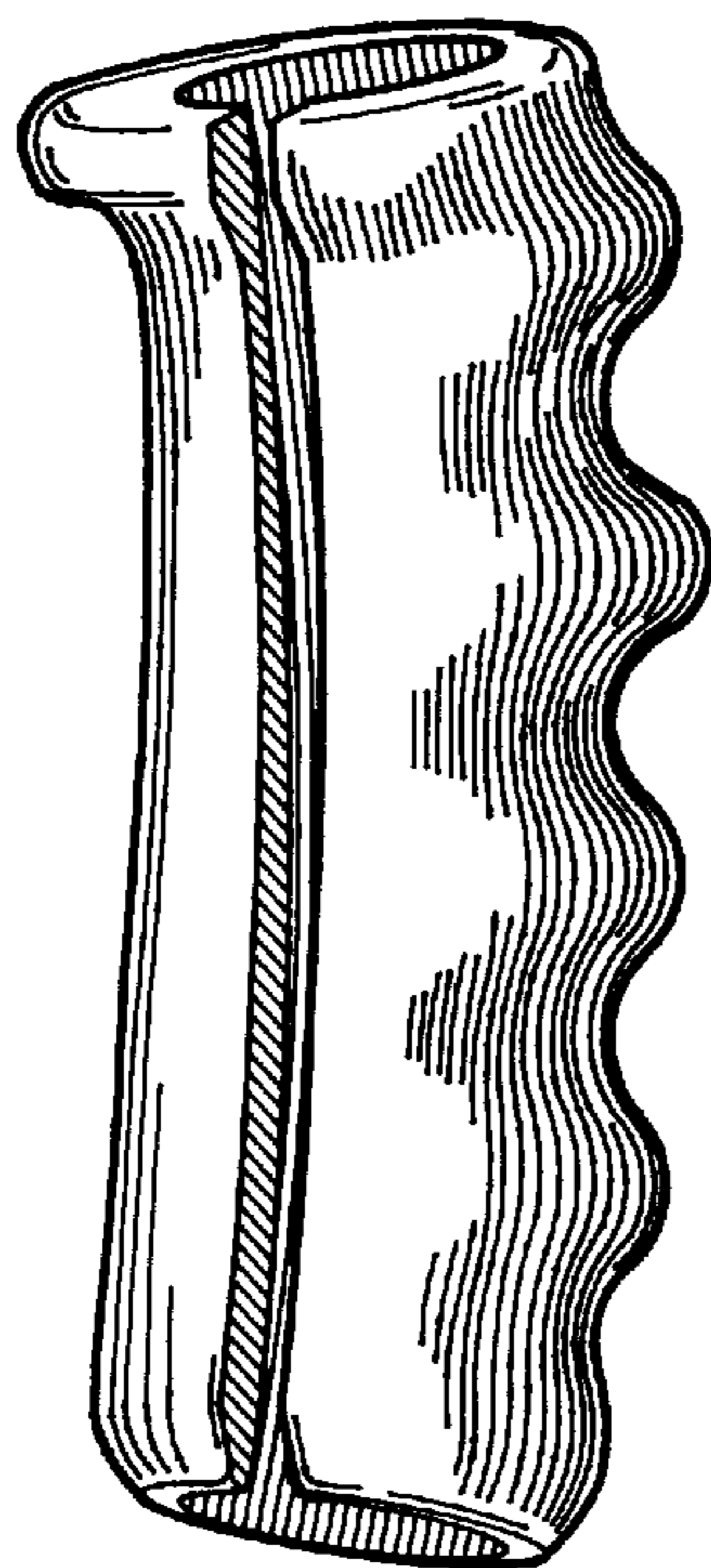

FIG. 10

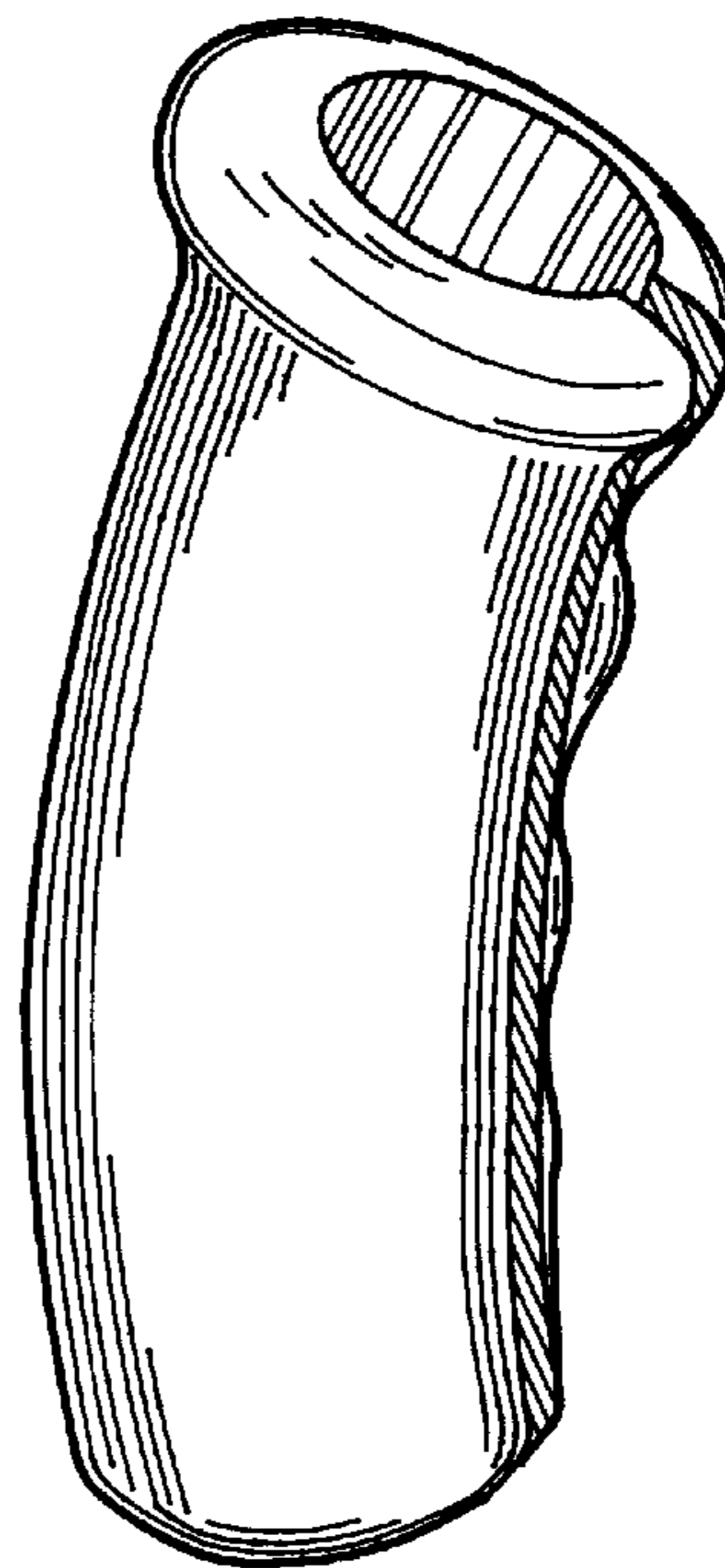

FIG. 11

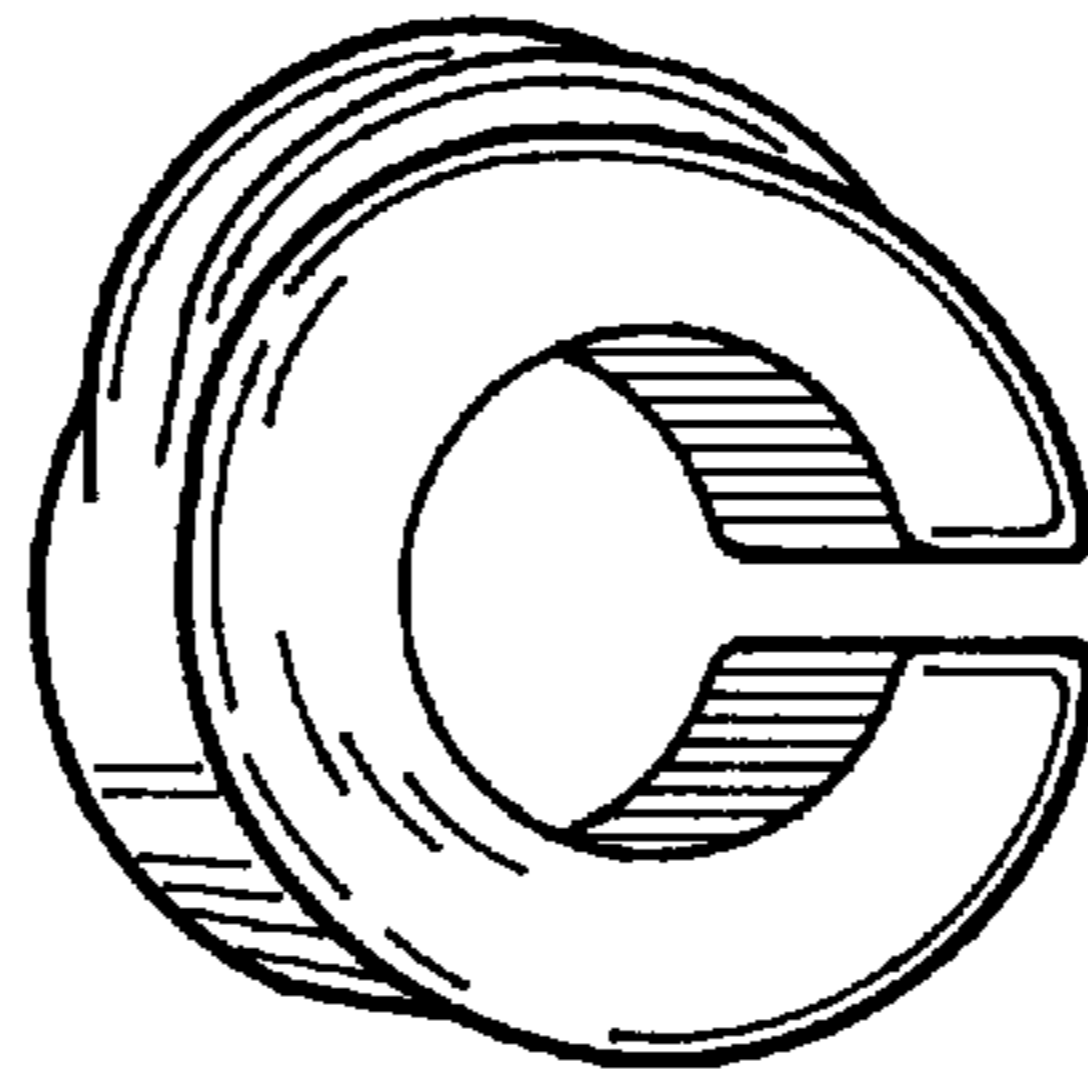

FIG. 15

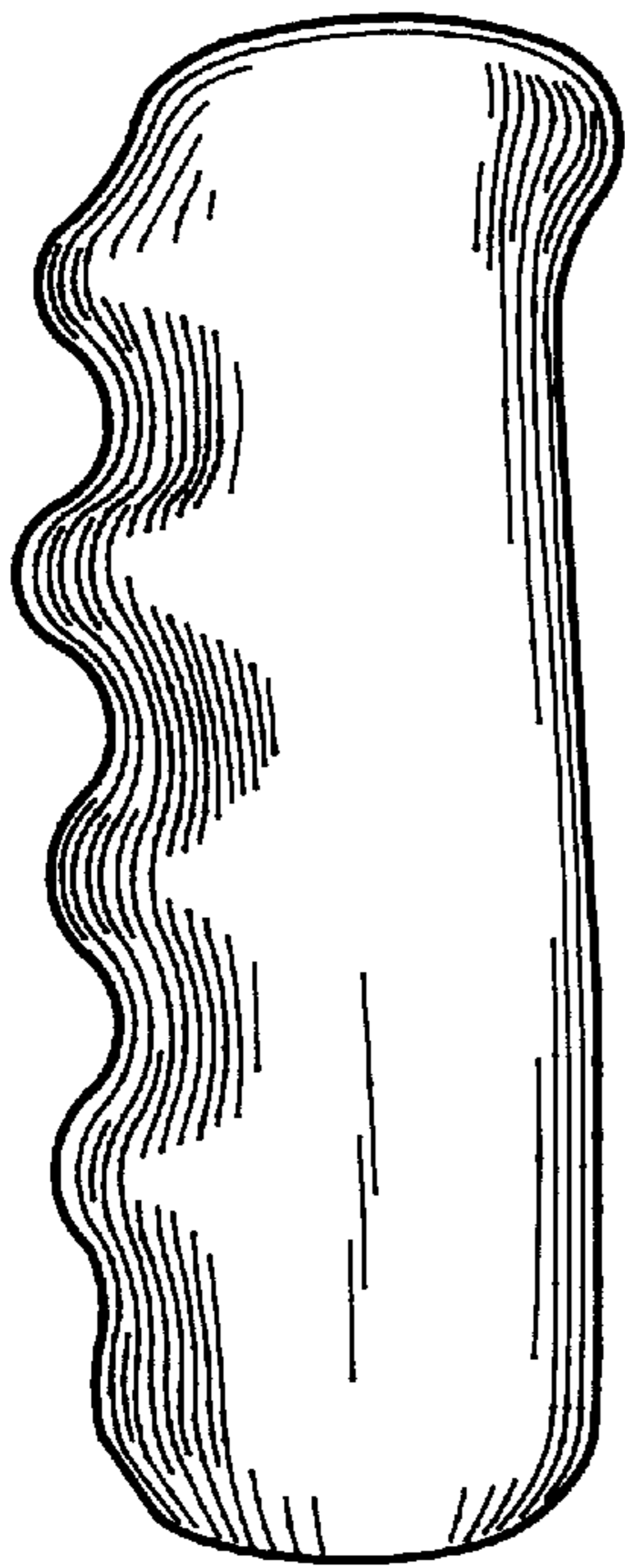

FIG. 13

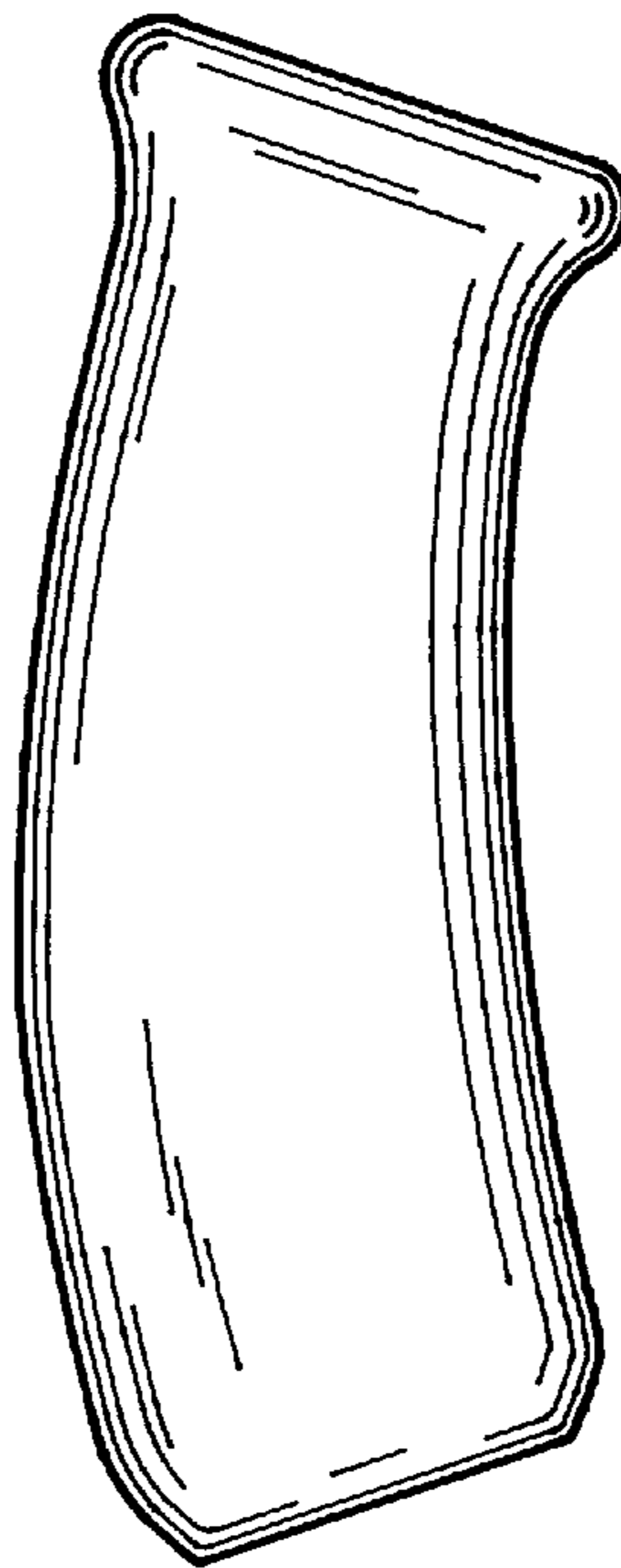

FIG. 12

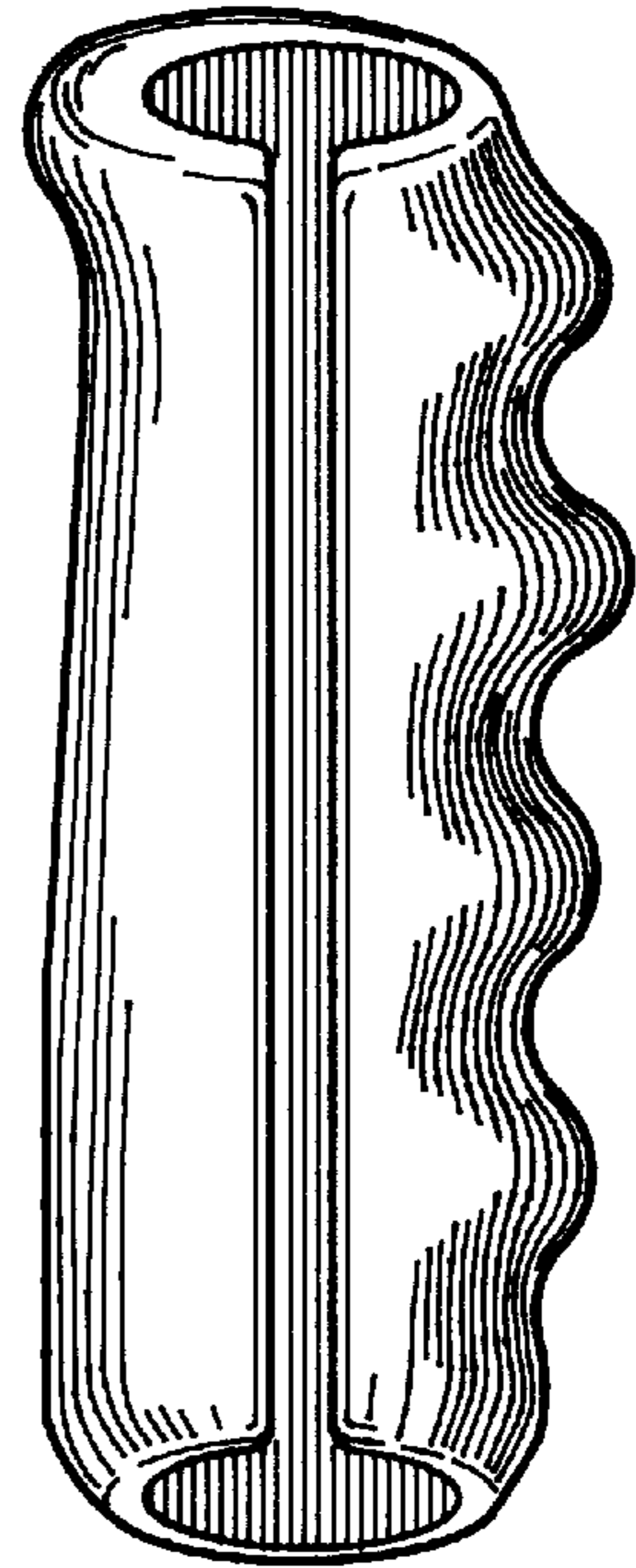

FIG. 14

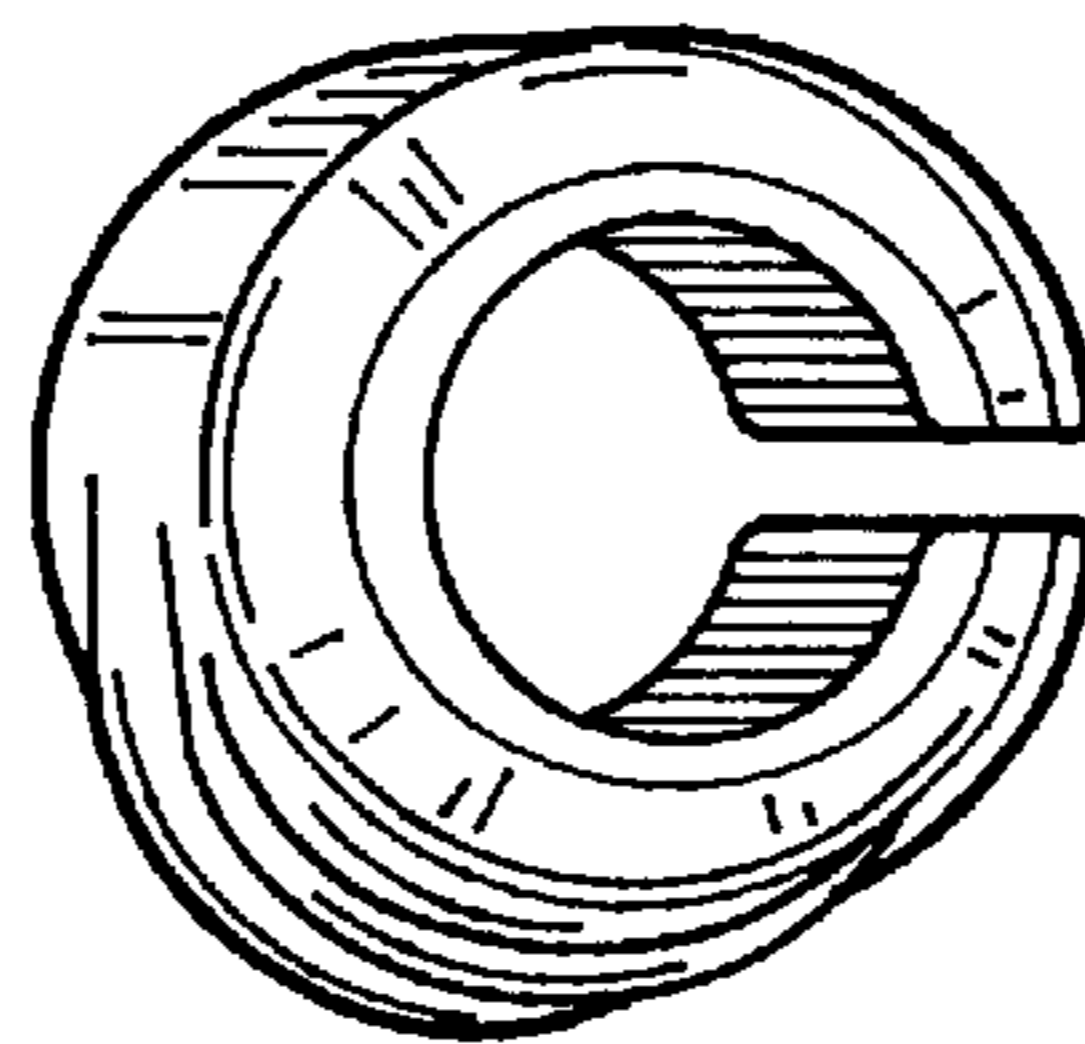

FIG. 16