



US00D403023S

United States Patent [19]
Araki

[11] **Patent Number: Des. 403,023**

[45] **Date of Patent: **Dec. 22, 1998**

[54] **CHASSIS OF RADIO-CONTROLLED MODEL VEHICLE**

[75] Inventor: **Shigeki Araki**, Shizuoka, Japan

[73] Assignee: **Tamiya, Inc.**, Shizuoka, Japan

[**] Term: **14 Years**

[21] Appl. No.: **75,788**

[22] Filed: **Aug. 25, 1997**

[51] **LOC (6) Cl.** **21-01**

[52] **U.S. Cl.** **D21/141**

[58] **Field of Search** D21/69-71, 73-81,
D21/128, 129, 131-132, 134, 136-137,
140-141; 446/454, 456, 457, 462, 465,
470, 440, 427; 280/1.13, 828, 87.01, 87.021,
47.11

[56] **References Cited**

U.S. PATENT DOCUMENTS

D. 282,677 2/1986 Arigaya D21/124

D. 332,979 2/1993 Tsuchiya D21/141
3,772,824 11/1973 Terzian et al. 446/454
4,187,637 2/1980 Nielsen 446/454
4,767,376 8/1988 Hanzawa 446/457
5,100,368 3/1992 Chien 446/462
5,597,165 1/1997 Rundle et al. 446/456

Primary Examiner—Raphael Barkai
Attorney, Agent, or Firm—Hughes Hubbard & Reed LLP

[57] **CLAIM**

The ornamental design for the chassis of radio-controlled model vehicle, as shown and described.

DESCRIPTION

FIG. 1 is a front elevational view of the chassis of radio-controlled model vehicle showing my new design; FIG. 2 is top plan view thereof; FIG. 3 is a rear view thereof; FIG. 4 is a left side elevational view thereof; FIG. 5 is a right side elevational view thereof; FIG. 6 is a bottom view thereof; and, FIG. 7 is a perspective view thereof.

1 Claim, 5 Drawing Sheets

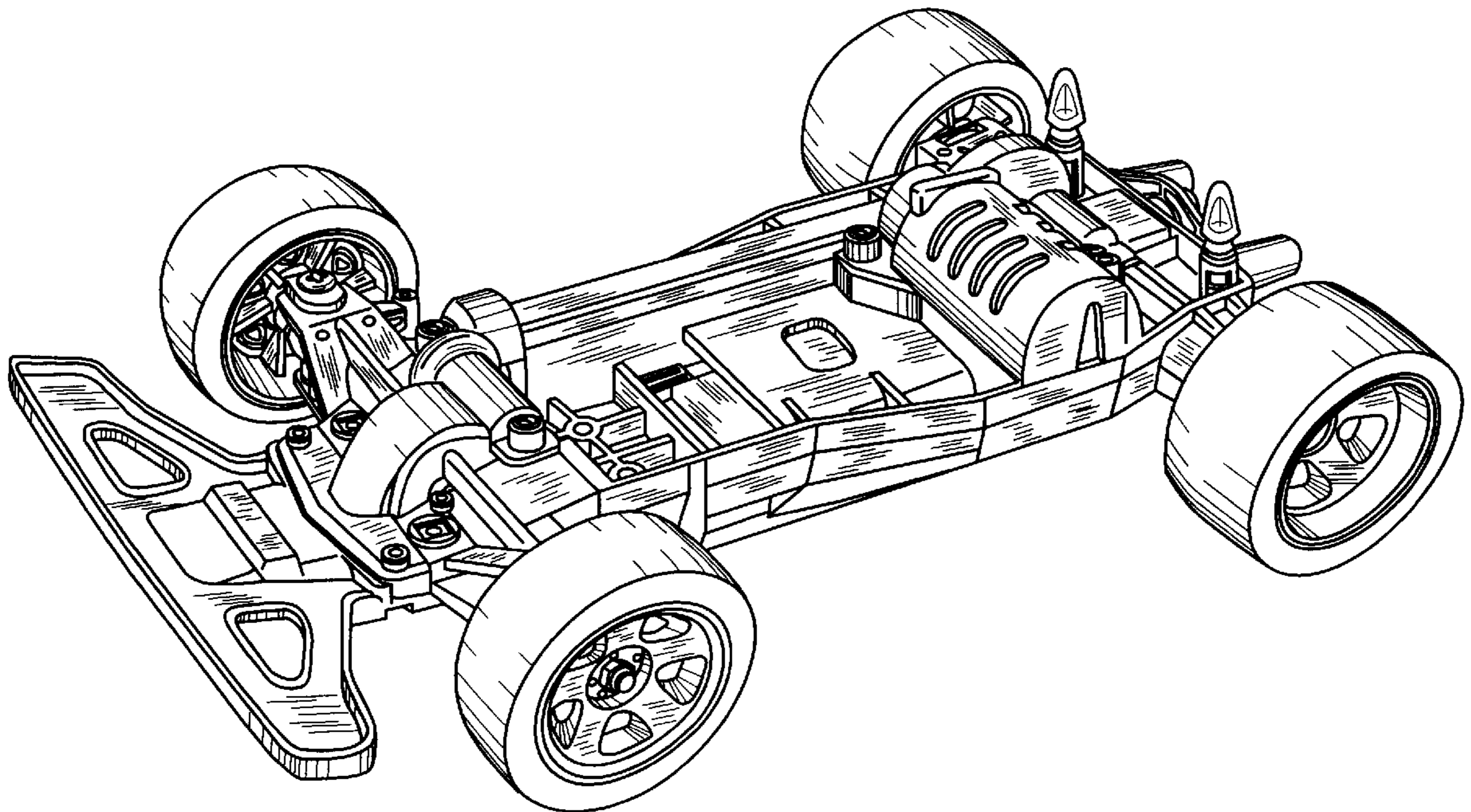

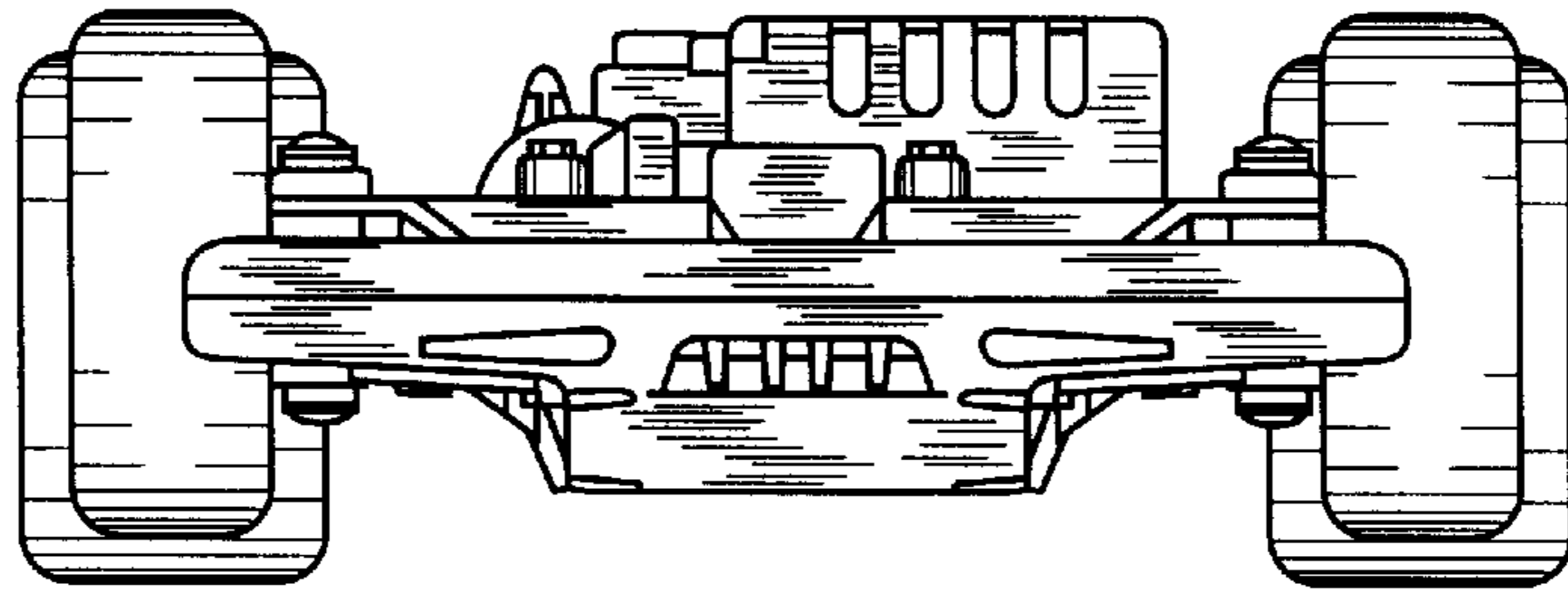

FIG. 1

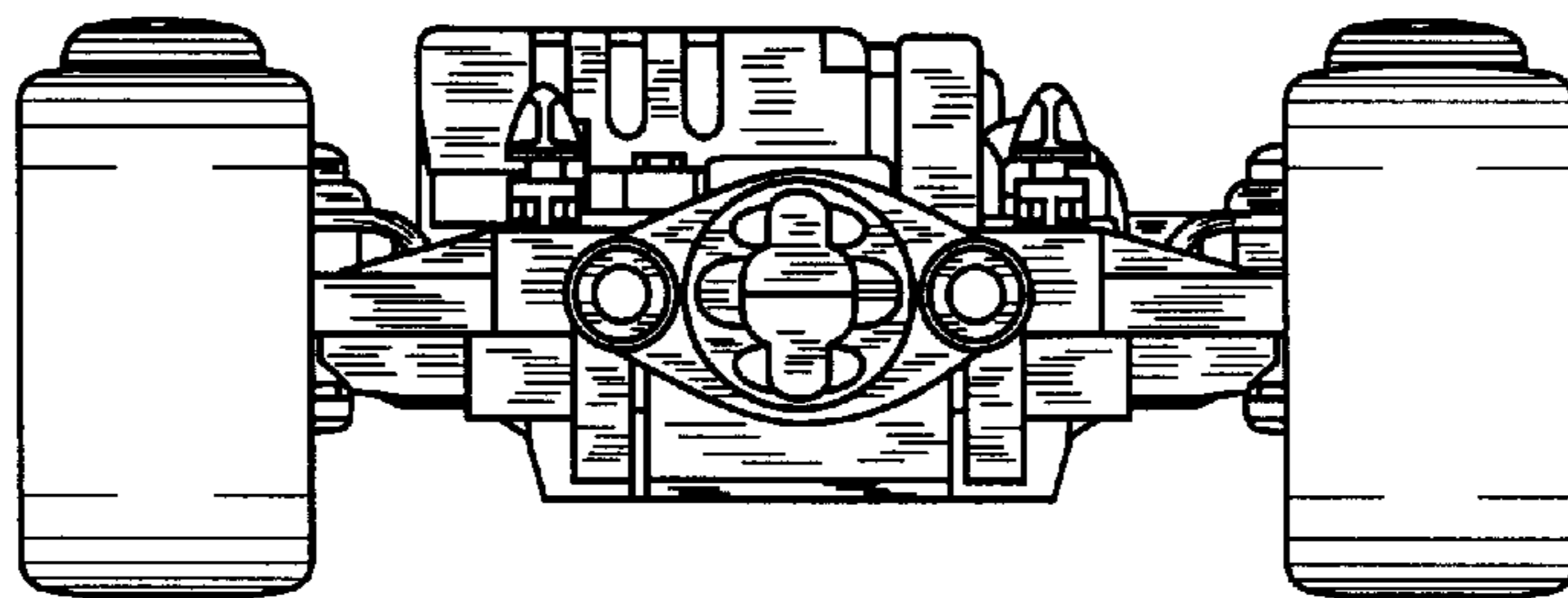

FIG. 3

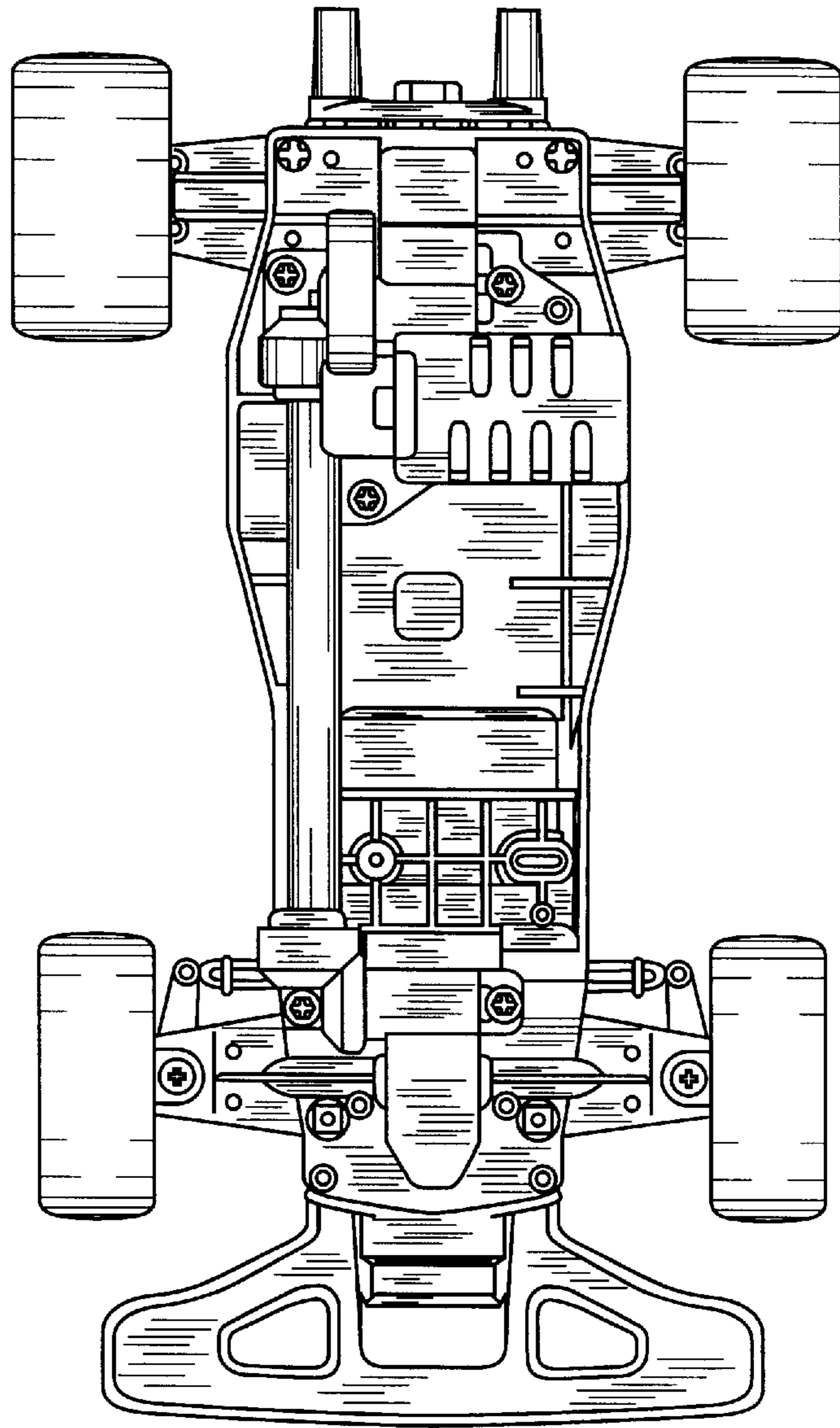

FIG. 2

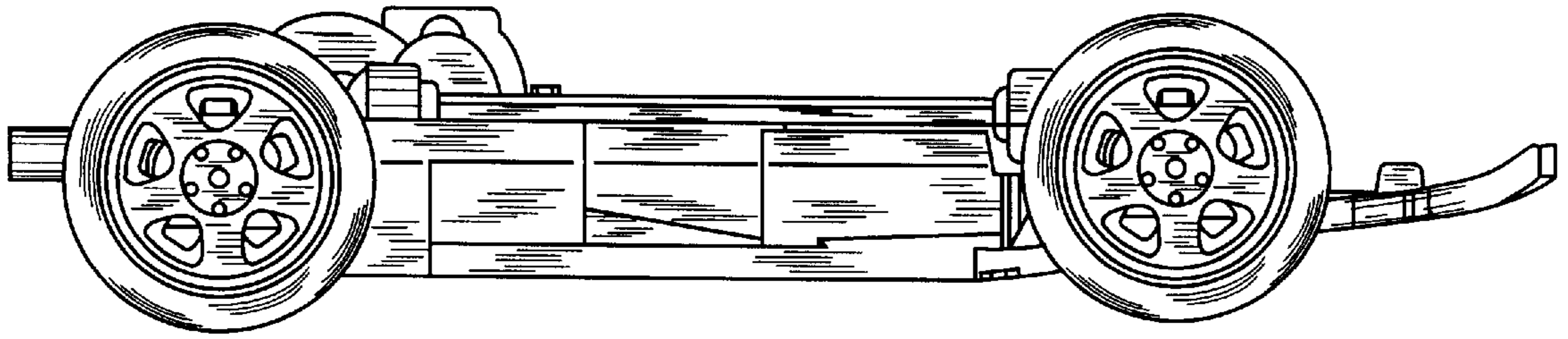

FIG. 4

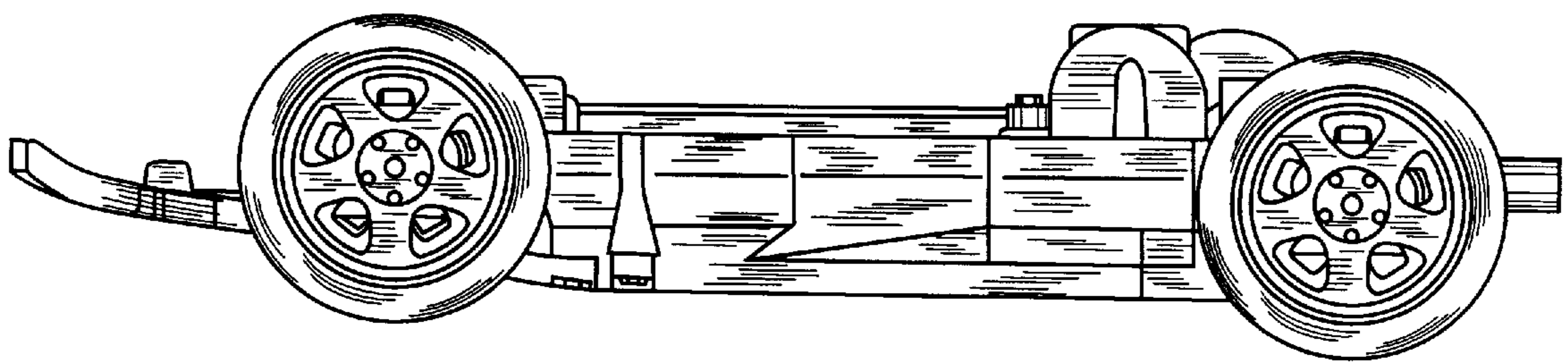

FIG. 5

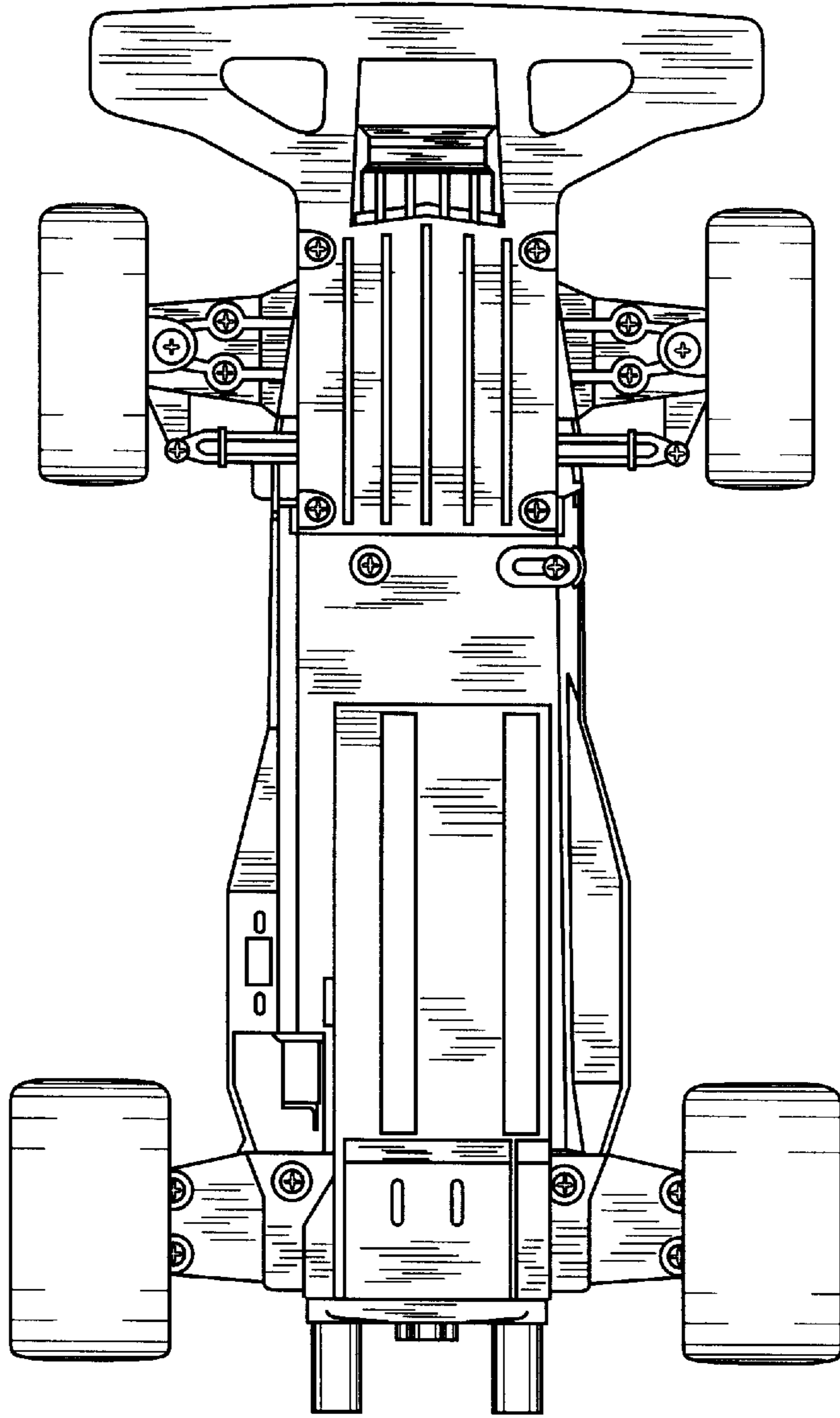

FIG. 6

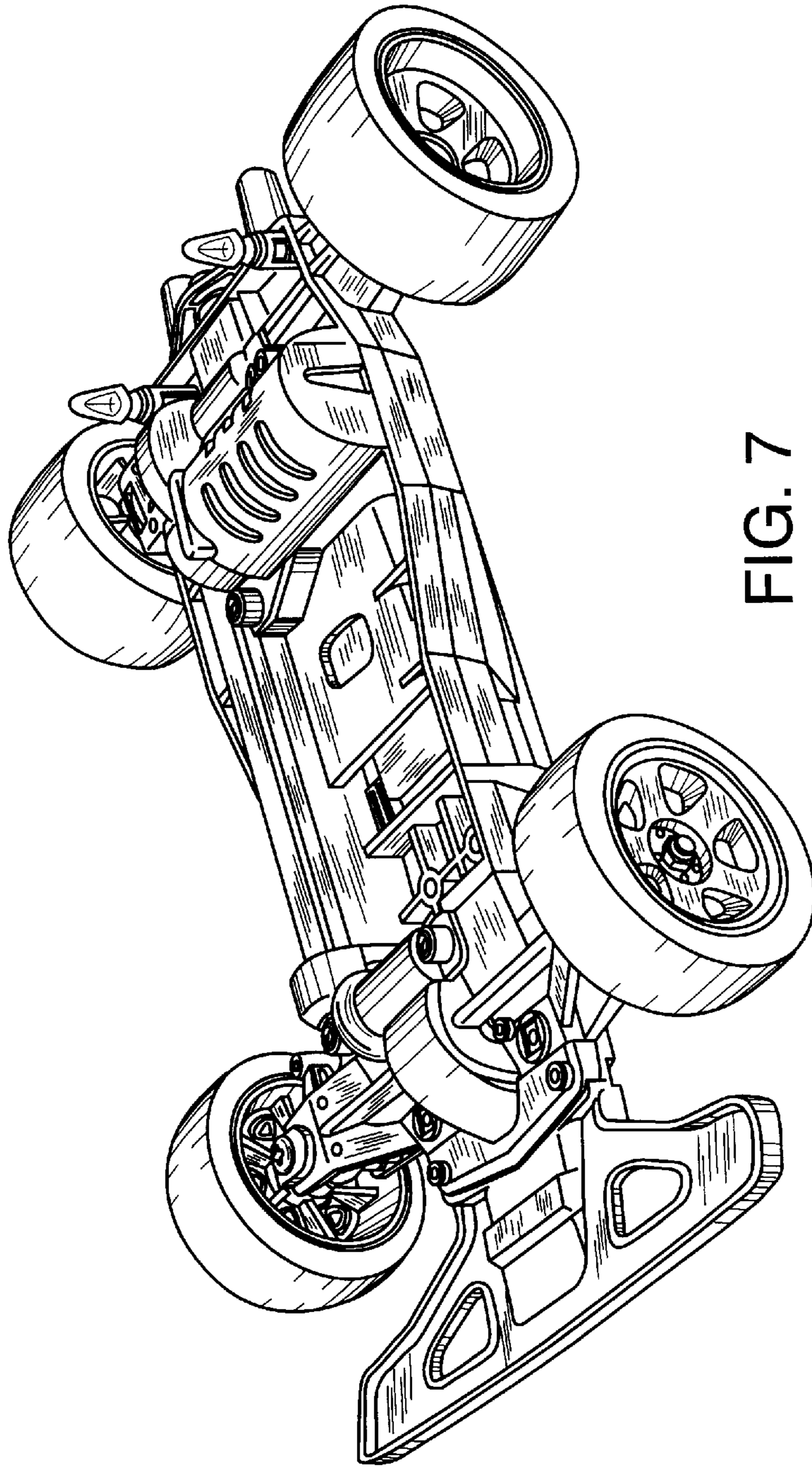

FIG. 7