



US00D402951S

United States Patent [19]

Wechner

[11] **Patent Number: Des. 402,951**

[45] **Date of Patent: **Dec. 22, 1998**

[54] **FRONT FACE OF A MOTOR VEHICLE WHEEL**

D. 344,924 3/1994 Braungart et al. D12/211
D. 363,910 11/1995 Chung D12/209
D. 375,075 10/1996 Kugler D12/209

[75] Inventor: **Daniel Wechner**, Munich, Germany

OTHER PUBLICATIONS

[73] Assignee: **Bayerische Motoren Werke Aktiengesellschaft**, Munich, Germany

1994 Custom Wheel and Tire Style Guide, See "Centra Type 22" Wheel, p. 37 and p. 244 Wheel, p. 34.

[**] Term: **14 Years**

Primary Examiner—James Gandy
Assistant Examiner—Stacia Sinuik
Attorney, Agent, or Firm—Evenson, McKeown, Edwards, & Lenahan PLLC

[21] Appl. No.: **79,696**

[22] Filed: **Nov. 21, 1997**

[30] Foreign Application Priority Data

May 21, 1997 [DE] Germany M 97 04 929.8

[51] **LOC (6) Cl.** **12-16**

[52] **U.S. Cl.** **D12/211**

[58] **Field of Search** D12/204-213;
301/64.1, 65, 37.1

[57] CLAIM

The ornamental design for a front face of a motor vehicle wheel, as shown and described.

DESCRIPTION

FIG. 1 is a side view of a front face of a motor vehicle wheel according to my novel design; and, FIG. 2 is a side perspective view of a front face of a motor vehicle wheel according to my novel design. The dash line showing depicts enviroment and is not part of the claimed design.

[56] References Cited

U.S. PATENT DOCUMENTS

D. 203,931 3/1966 Hibbard D12/211
D. 268,750 4/1983 Eichstadt D12/209
D. 339,561 9/1993 Maiworm et al. D12/211

1 Claim, 1 Drawing Sheet

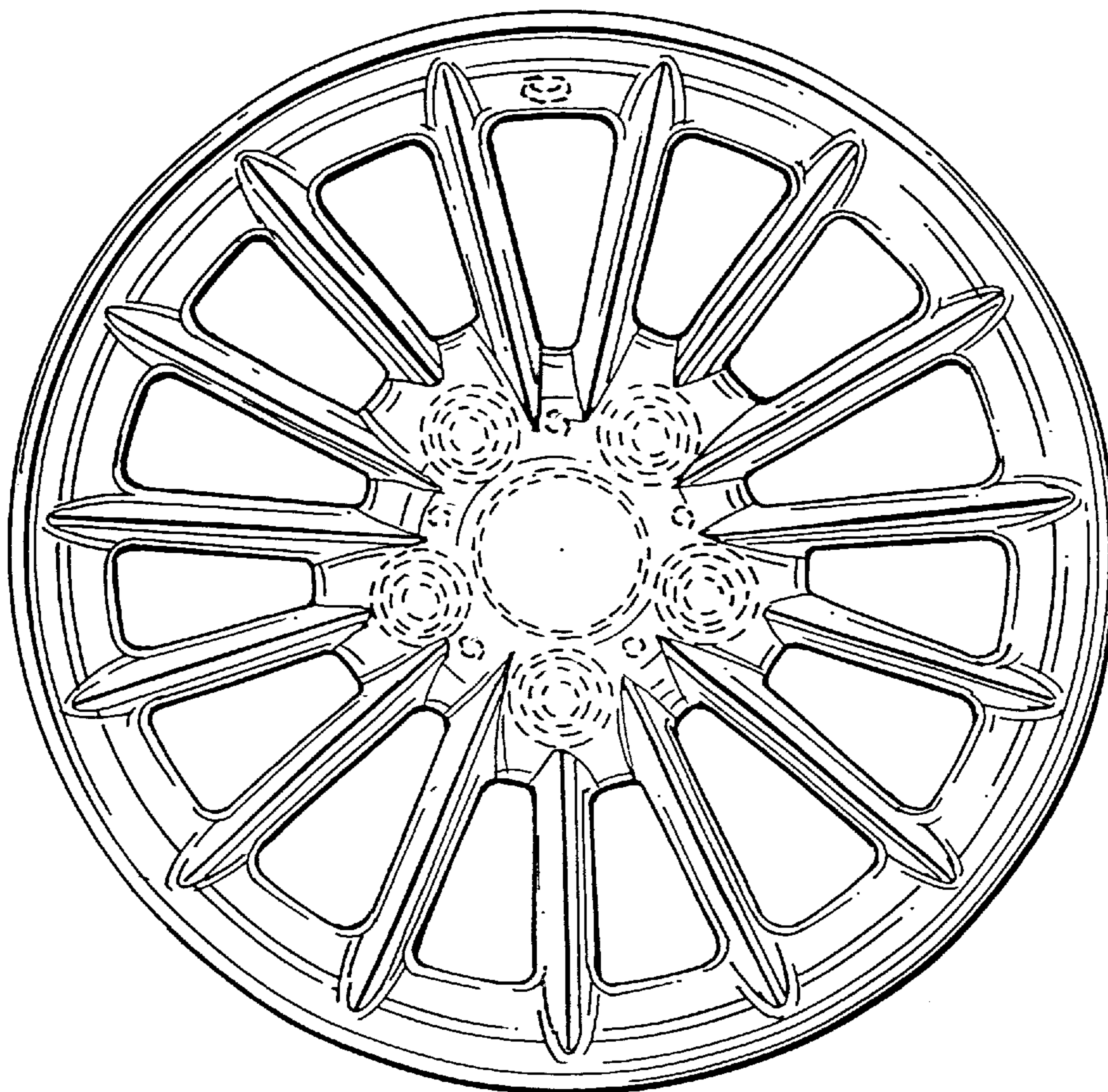

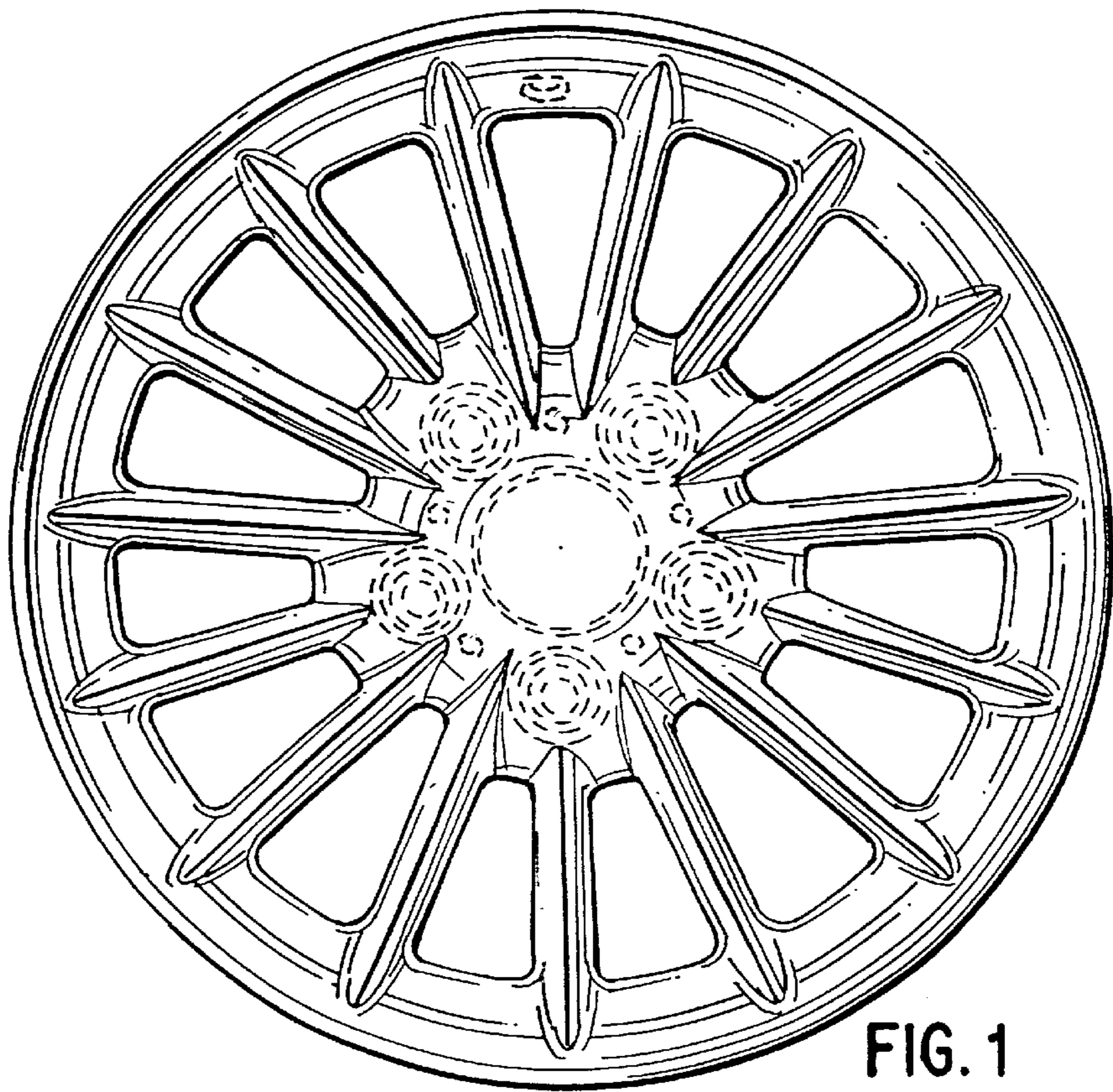

FIG. 1

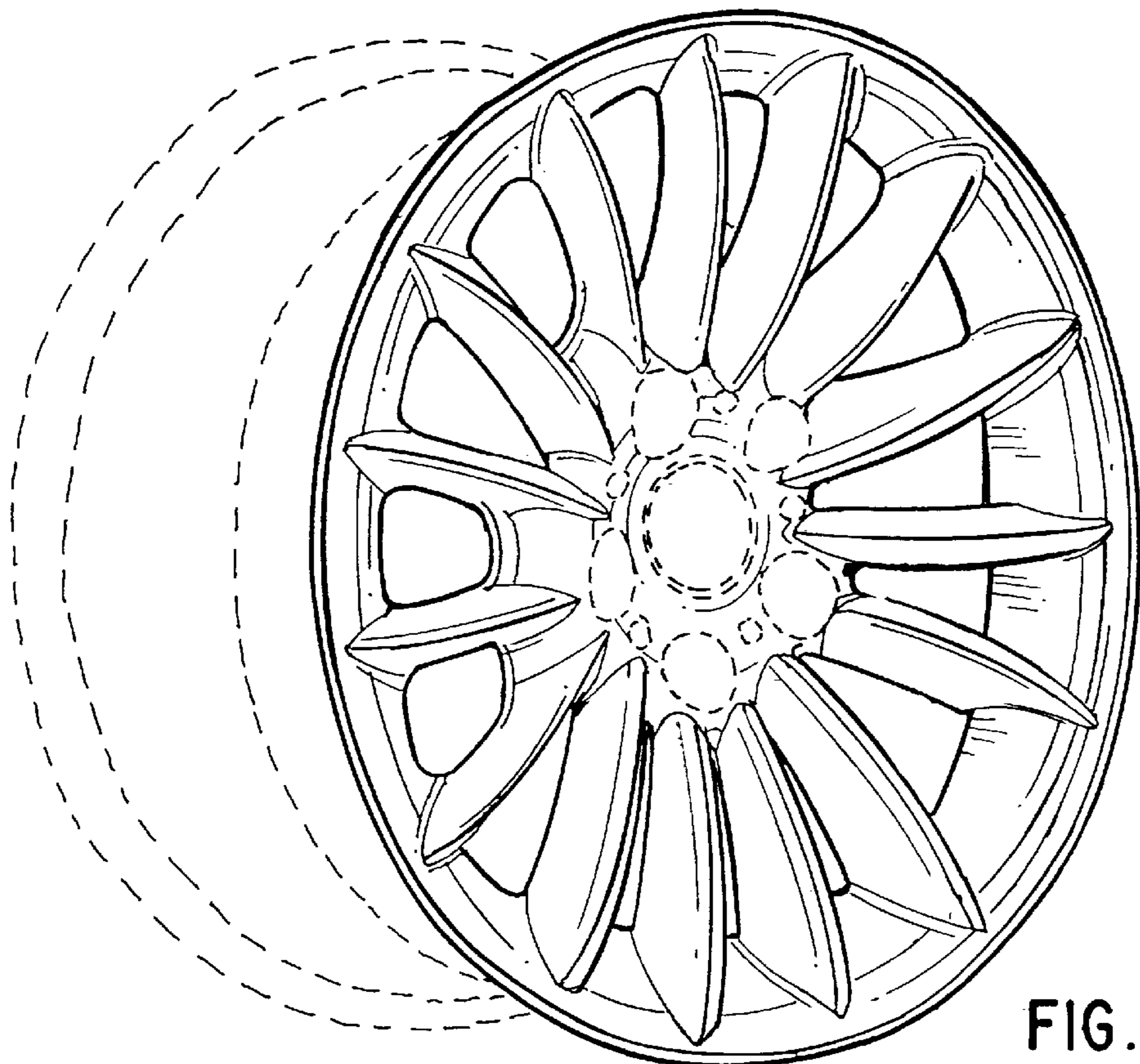

FIG. 2