



US00D402930S

United States Patent [19]

[11] Patent Number: Des. 402,930

Baechler et al.

[45] Date of Patent: **Dec. 22, 1998

[54] BABY STROLLER CONVERSION UNIT

5,474,316	12/1995	Britton	280/204
5,577,746	11/1996	Britton	280/204
5,599,033	2/1997	Kolbus et al.	280/204
5,695,208	12/1997	Baechler et al.	280/204

[75] Inventors: Philip A. Baechler; Joseph P. Delorme; Michael F. Arnold, all of Yakima, Wash.

Primary Examiner—Melody N. Brown
Attorney, Agent, or Firm—Seed and Berry LLP

[73] Assignee: Racing Strollers, Inc., Yakima, Wash.

[**] Term: 14 Years

[57] CLAIM

[21] Appl. No.: 57,128

The ornamental design for a baby stroller conversion unit, as shown and described.

[22] Filed: Jul. 17, 1996

DESCRIPTION

Related U.S. Application Data

[63] Continuation-in-part of Ser. No. 530,787, Sep. 19, 1995, Pat. No. 5,695,208.

FIG. 1 is a perspective view of a baby stroller conversion unit showing our new design;

[51] LOC (6) Cl. 12-12

FIG. 2 is a left-side elevational view thereof, the opposite right-side being a mirror image thereof;

[52] U.S. Cl. D12/133; D12/101

FIG. 3 is a top-plan view thereof;

[58] Field of Search D12/114, 128, D12/129, 133; 280/30, 36, 202, 203, 204, 644, 647-650

FIG. 4 is a bottom-plan view thereof;

FIG. 5 is a front elevational view thereof;

FIG. 6 is a rear elevational view thereof;

FIG. 7 is a perspective view of a baby stroller conversion unit showing a second embodiment of our new design;

FIG. 8 is a left-side elevational view of FIG. 7, the opposite right-side being a mirror image of that left-side shown in FIG. 8;

[56] References Cited

U.S. PATENT DOCUMENTS

D. 369,579	5/1996	Baechler	D12/133
D. 370,194	5/1996	Baechler et al.	D34/12
5,071,146	12/1991	Lewis et al.	280/30
5,176,395	1/1993	Garforth-Zles	280/204
5,292,142	3/1994	Vitorelli	280/203
5,421,597	6/1995	Berner	280/204
5,454,578	10/1995	Neack	280/204
5,460,395	10/1995	Chen	280/204

FIG. 9 is a top-plan view of FIG. 7;

FIG. 10 is a bottom-plan view of FIG. 7;

FIG. 11 is a front-elevational view of FIG. 7; and,

FIG. 12 is a rear-elevational view of FIG. 7.

The broken lines shown in all drawing views are for illustrative purposes only and form no part of the claimed design.

1 Claim, 6 Drawing Sheets

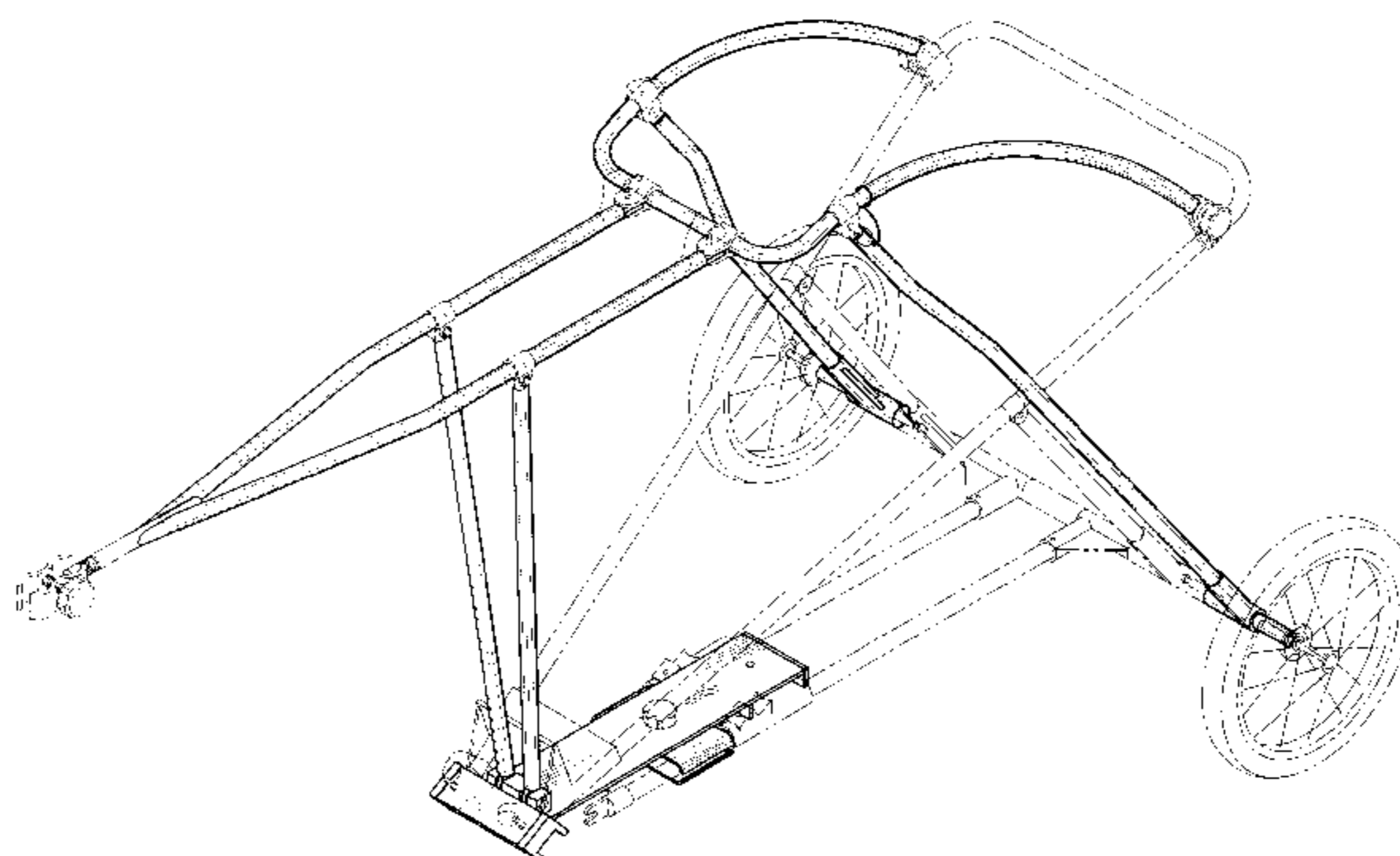
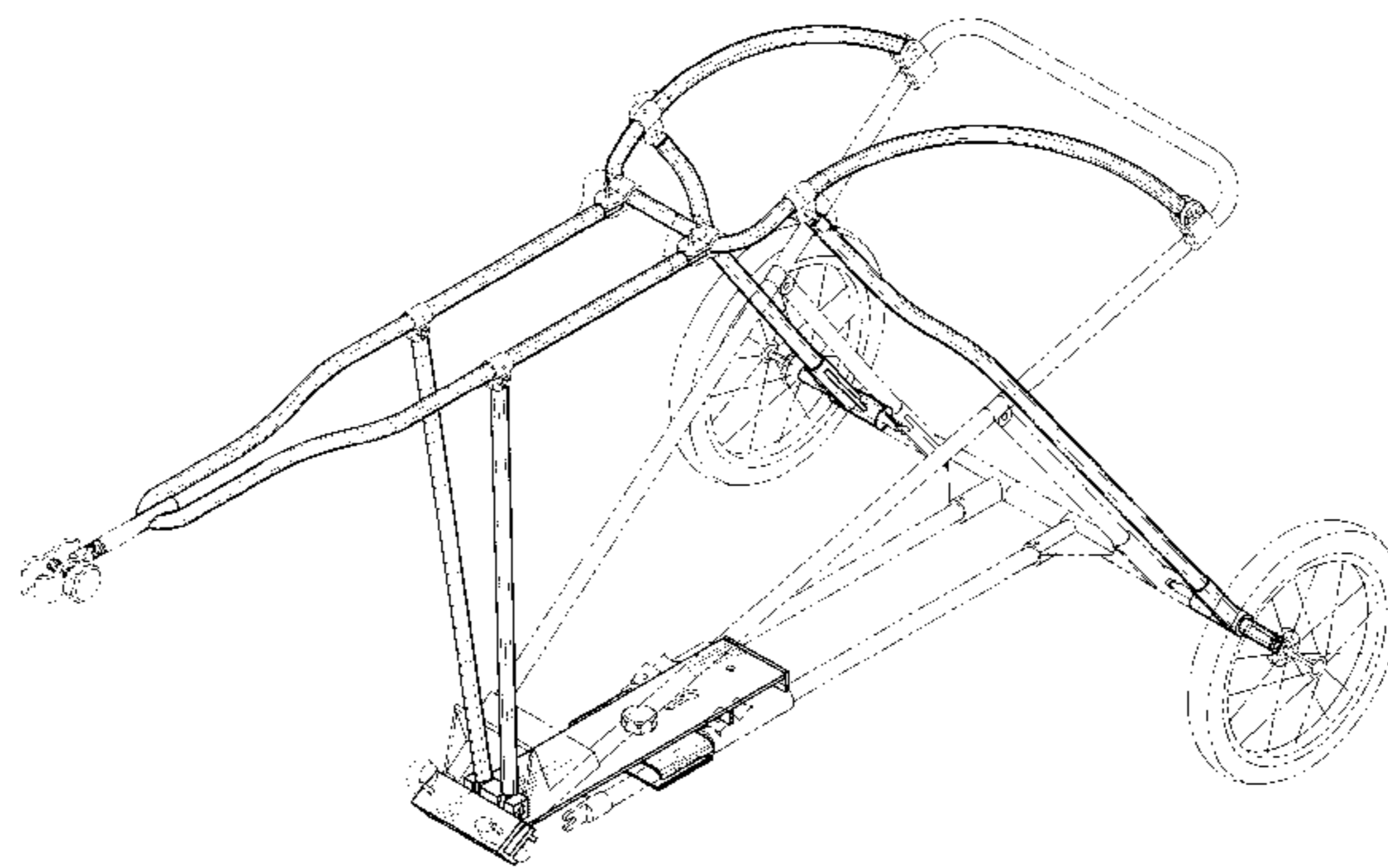

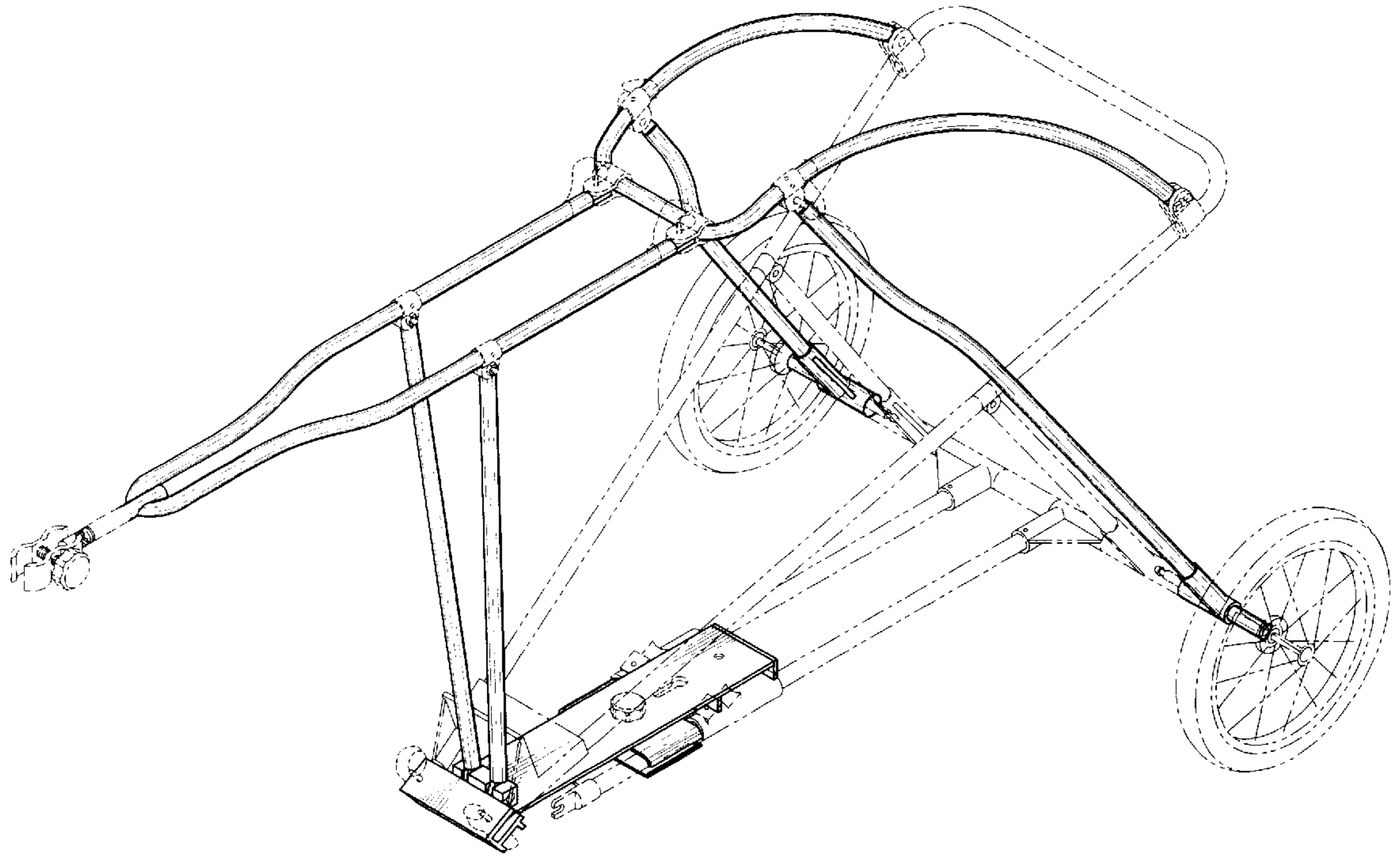

Fig. 1

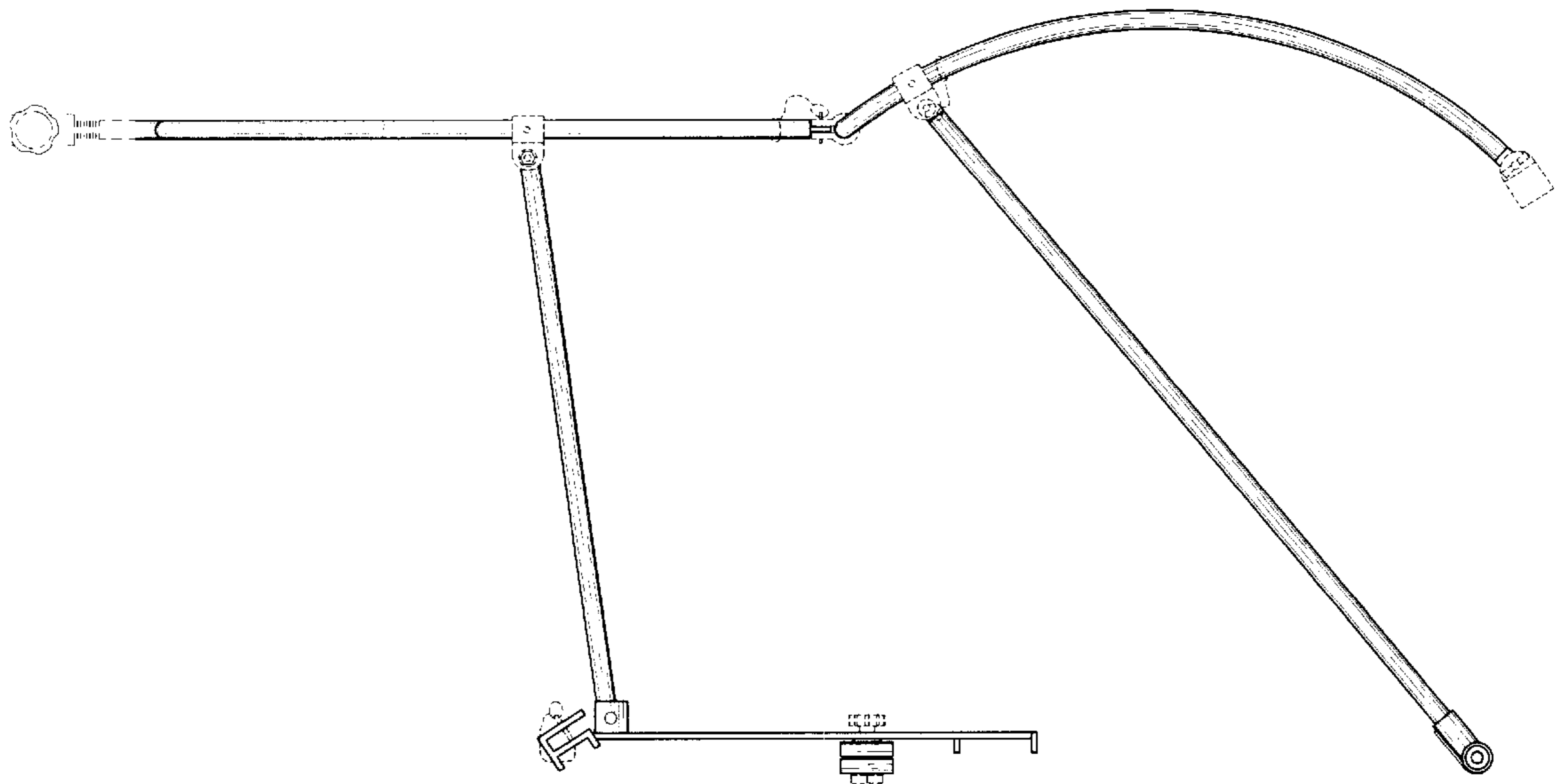

Fig. 2

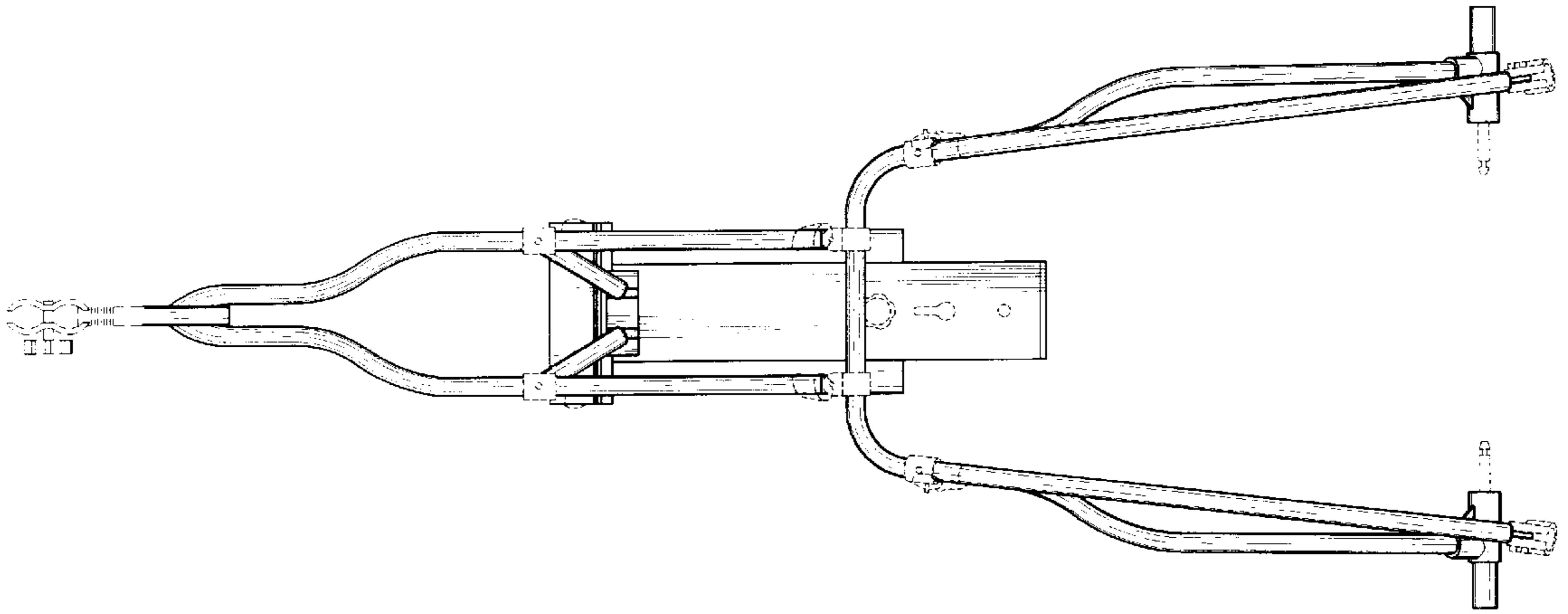

Fig. 3

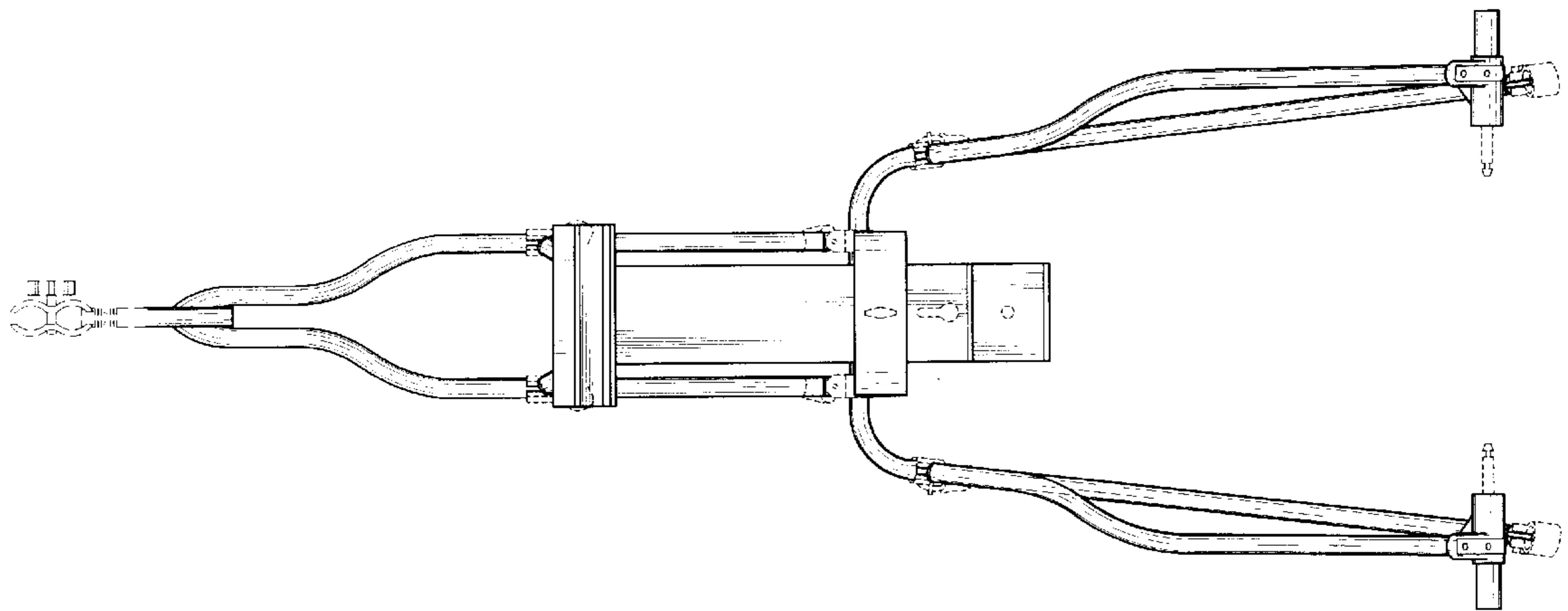

Fig. 4

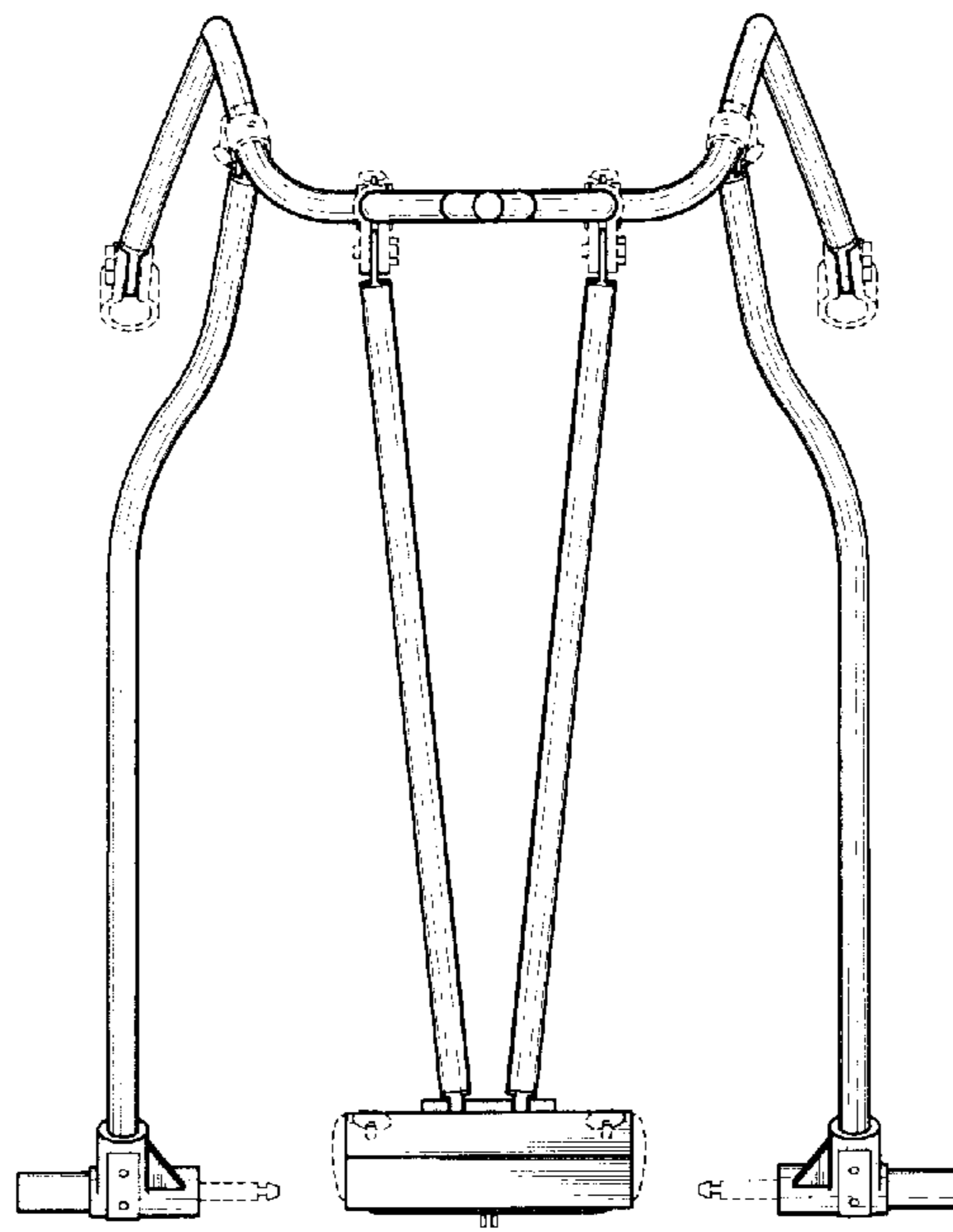

Fig. 5

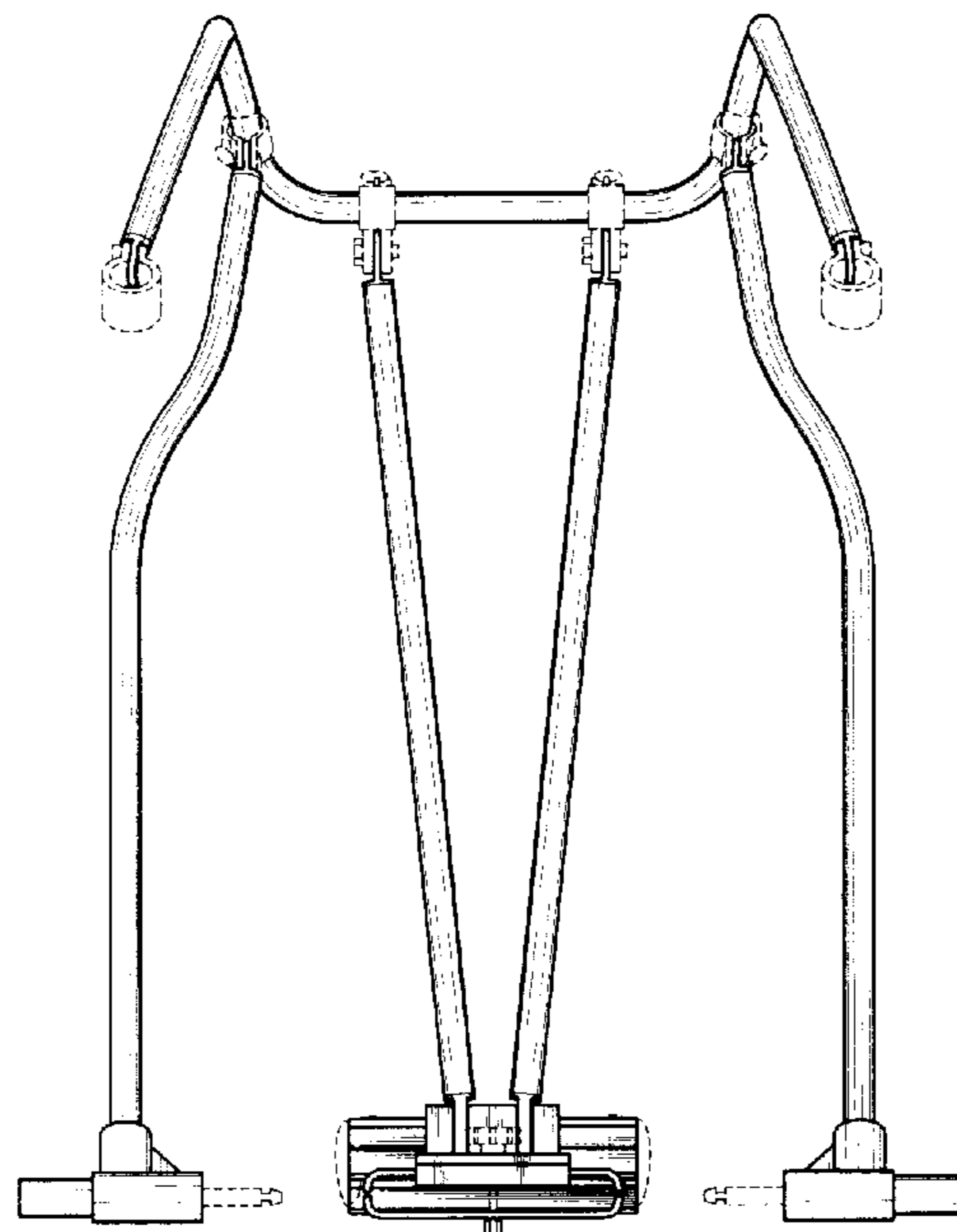

Fig. 6

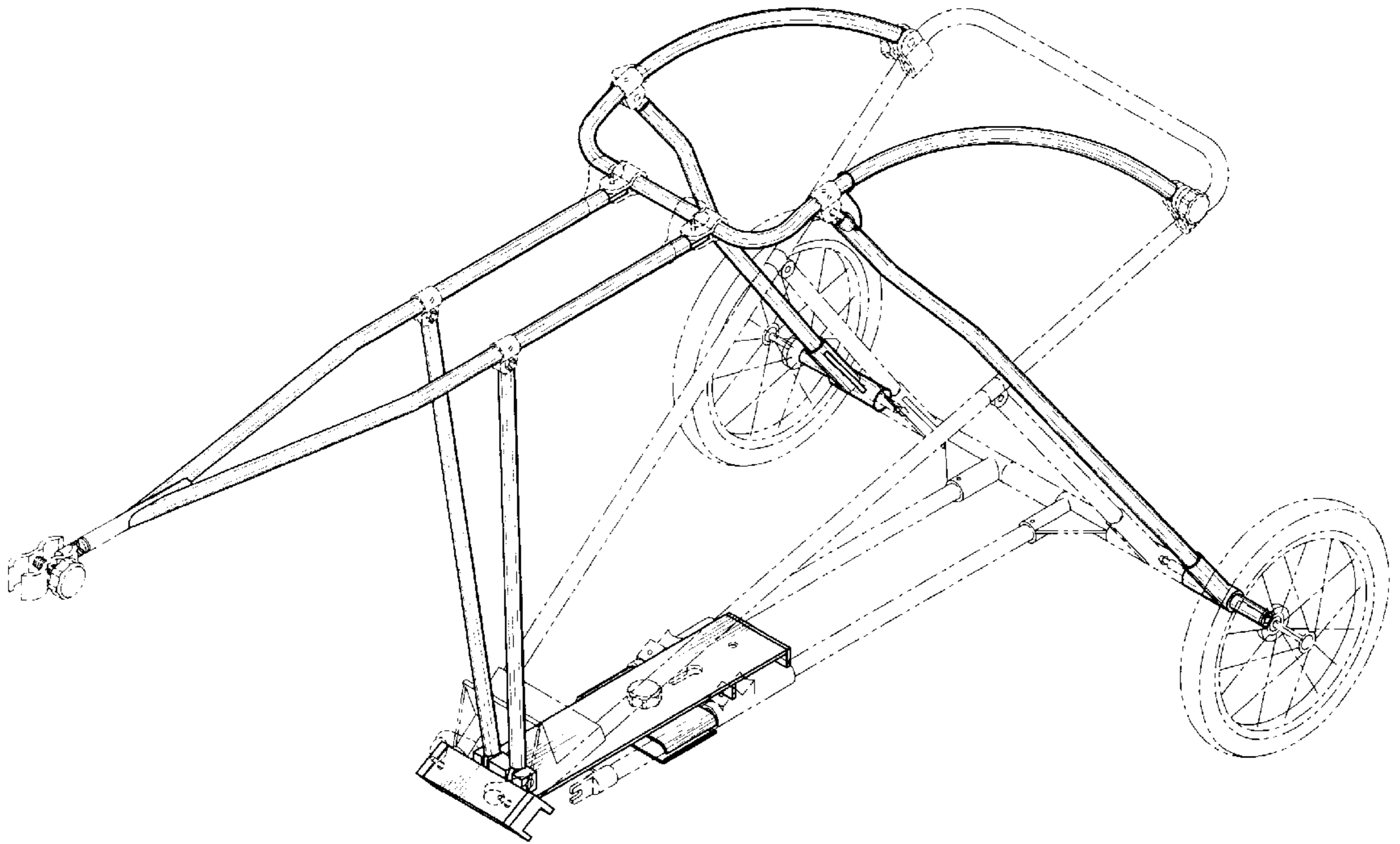

Fig. 7

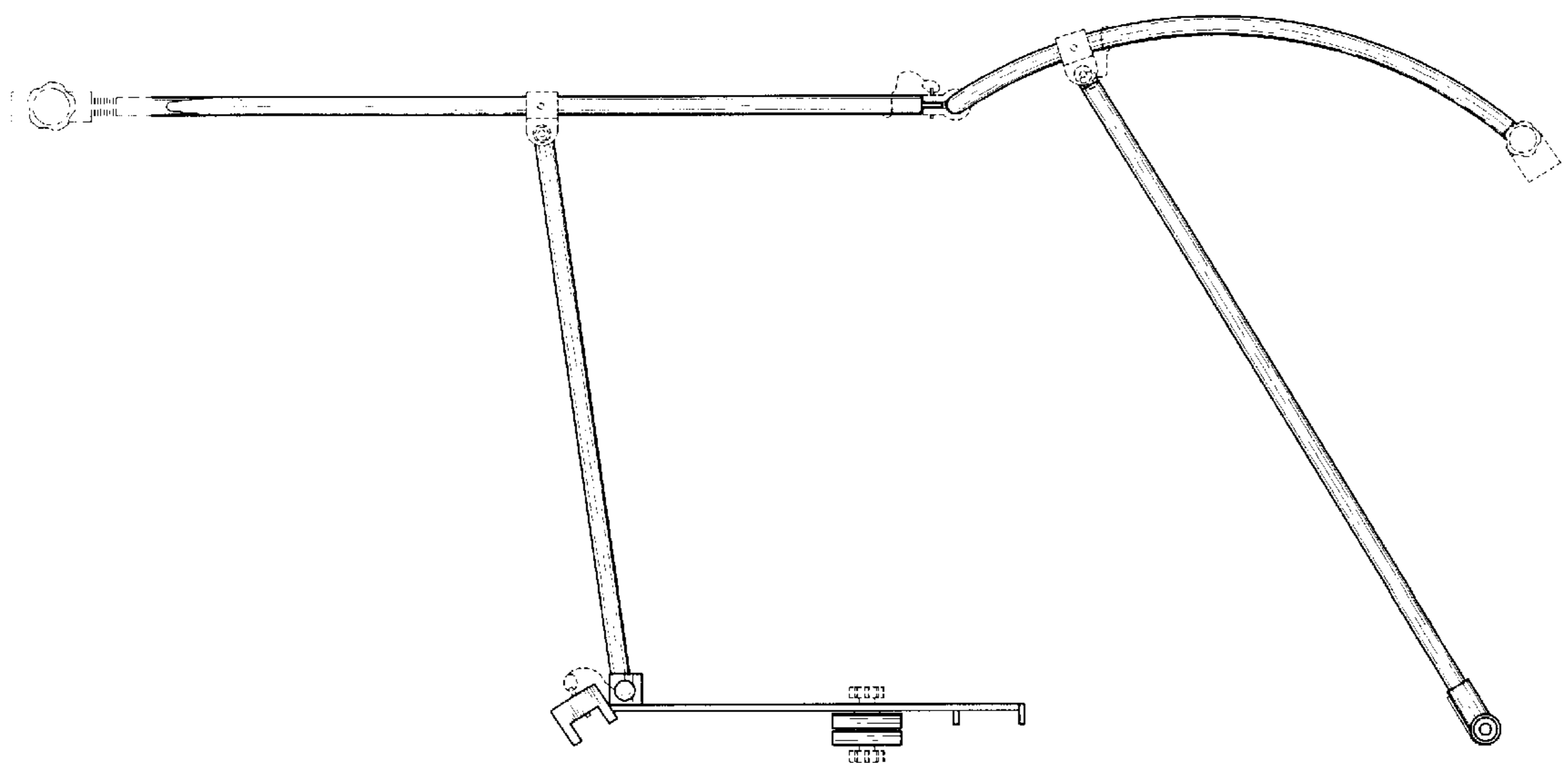

Fig. 8

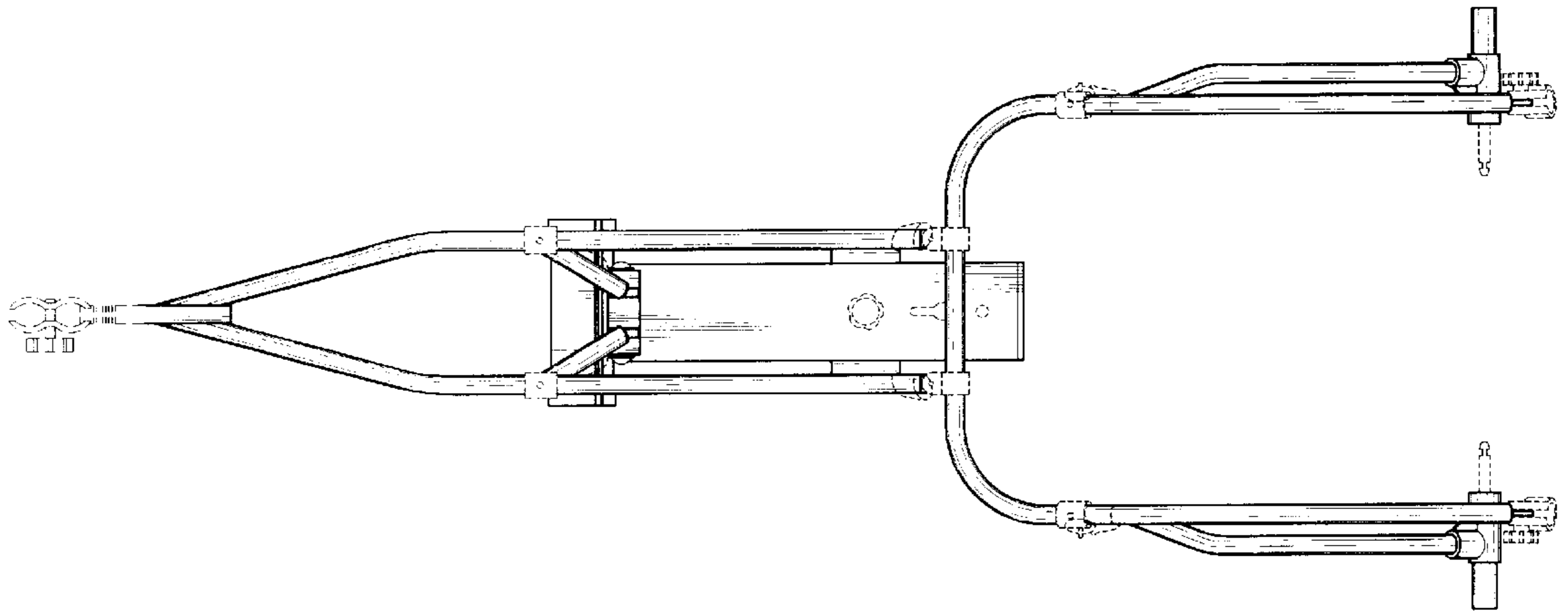

Fig. 9

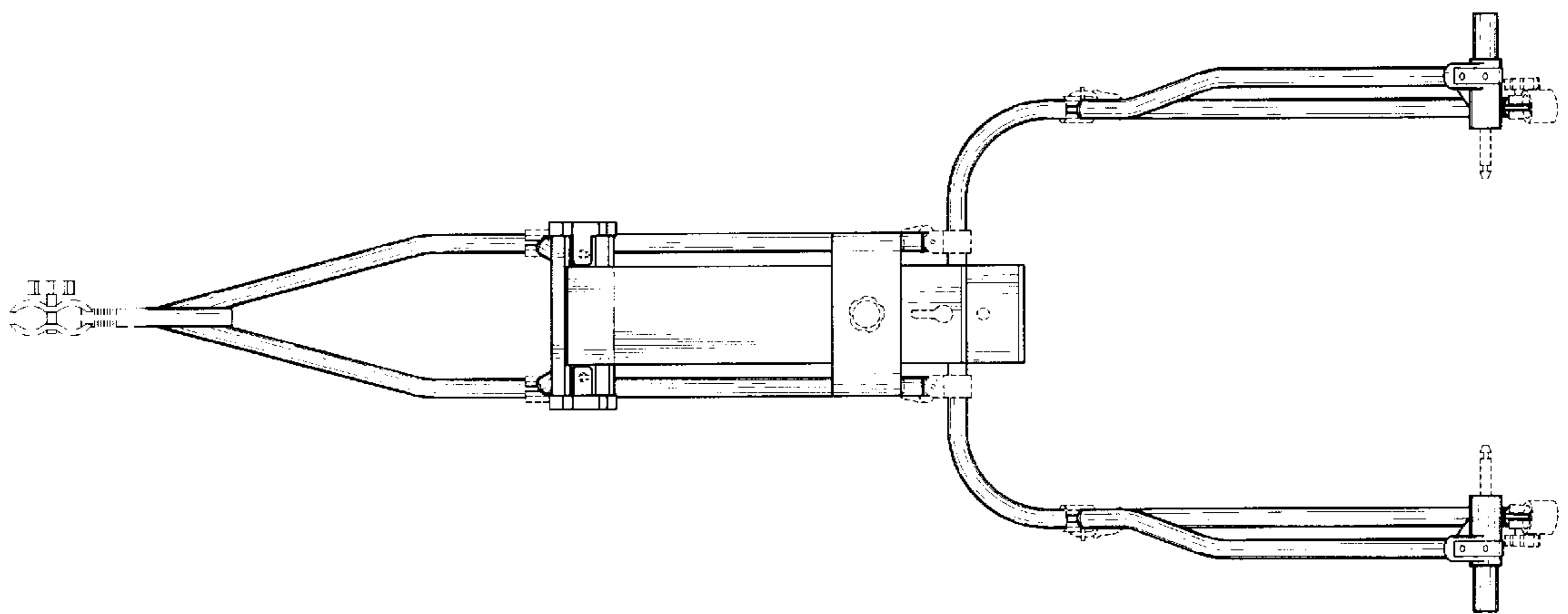

Fig. 10

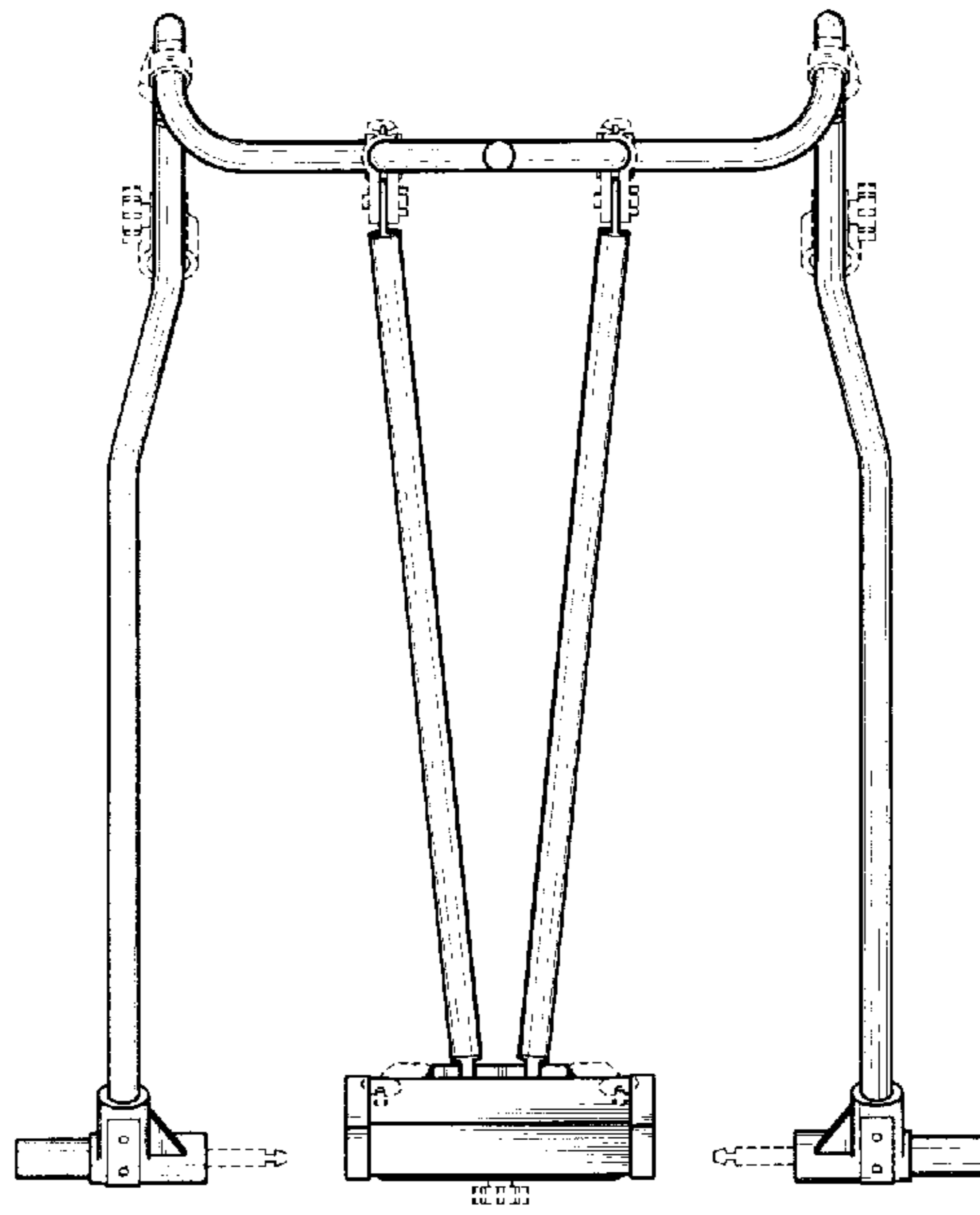

Fig. 11

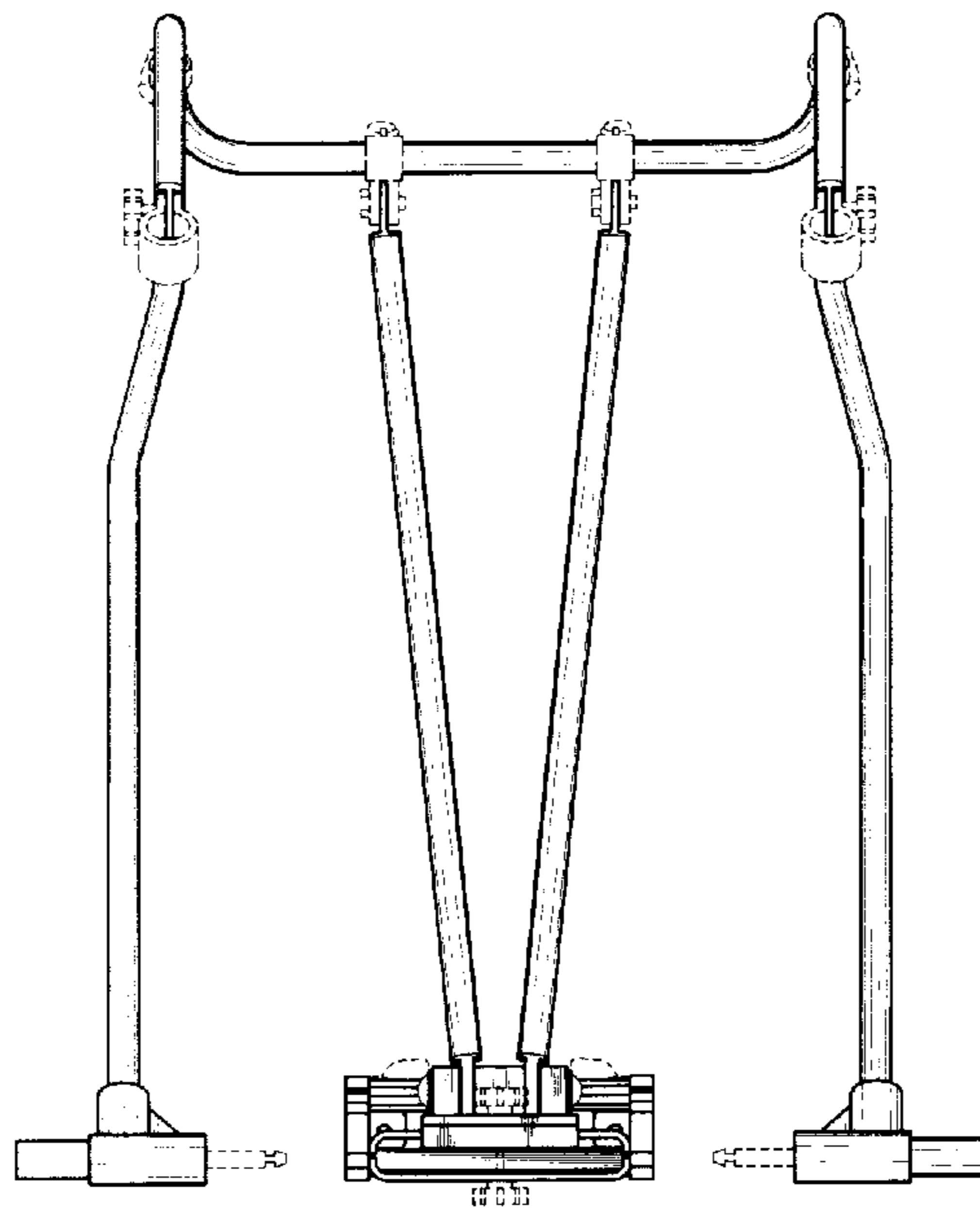

Fig. 12