



US00D402921S

United States Patent [19] Hamblin

[11] Patent Number: **Des. 402,921**

[45] Date of Patent: *****Dec. 22, 1998**

[54] **AUTOMOBILE**

[75] Inventor: **Richard David Hamblin**, Solihull,
United Kingdom

[73] Assignee: **Rolls-Royce Motor Cars Limited**,
Cheshire, England

[*] Notice: The portion of the term of this patent
subsequent to Jul. 14, 2012, has been
disclaimed.

[**] Term: **14 Years**

[21] Appl. No.: **62,699**

[22] Filed: **Nov. 21, 1996**

[30] **Foreign Application Priority Data**

May 23, 1996 [GB] United Kingdom 2056489

[51] **LOC (6) Cl.** **12-08**

[52] **U.S. Cl.** **D12/92**

[58] **Field of Search** D12/86, 90-92;
296/185

[56] **References Cited**

U.S. PATENT DOCUMENTS

D. 236,706 9/1975 Pinifarina D12/92

D. 353,351	12/1994	Hefferman et al.	D12/92
D. 368,879	4/1996	Gould	D12/92
D. 371,329	7/1996	Axe	D12/92
D. 373,978	9/1996	Axe et al.	D12/92
D. 374,198	10/1996	Axe et al.	D12/92

OTHER PUBLICATIONS

Road & Track, Jun. 1995, p. 67 Bentley Turbos.

Primary Examiner—Melody N. Brown
Attorney, Agent, or Firm—Cushman Darby Cushman
Intellectual Property Group of Pillsbury Madison & Sutro
LLP

[57] **CLAIM**

The ornamental design for an automobile, as shown and
described.

DESCRIPTION

FIG. 1 is a front view in elevation of the automobile;
FIG. 2 is a rear view in elevation of the automobile of FIG.
1;
FIG. 3 is a side view of the automobile of FIG. 1;
FIG. 4 is a view similar to FIG. 3 but showing the opposite
side of the automobile; and,
FIG. 5 is a top plan view.

1 Claim, 4 Drawing Sheets

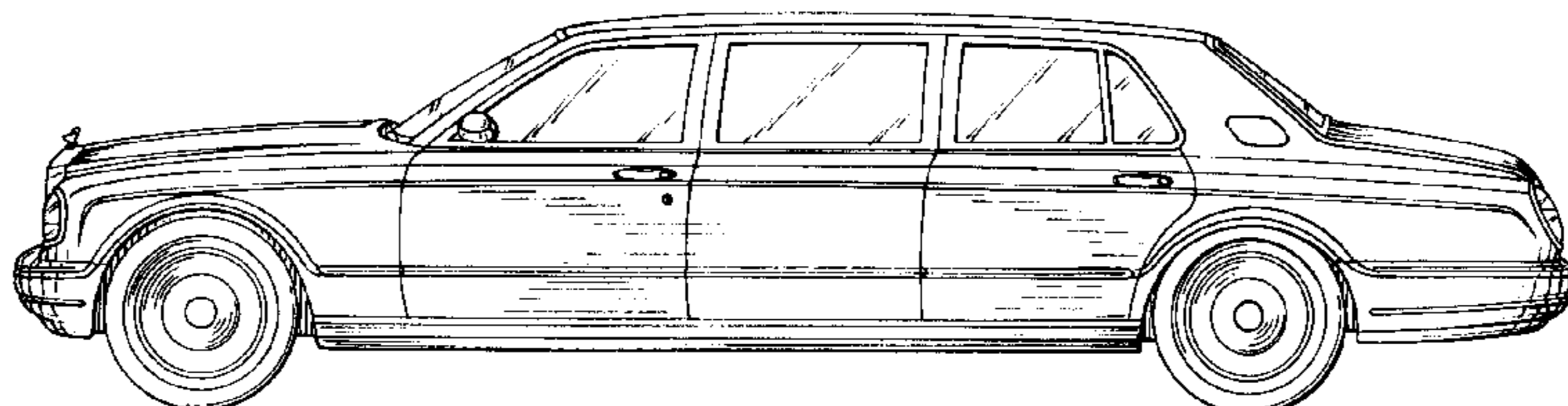
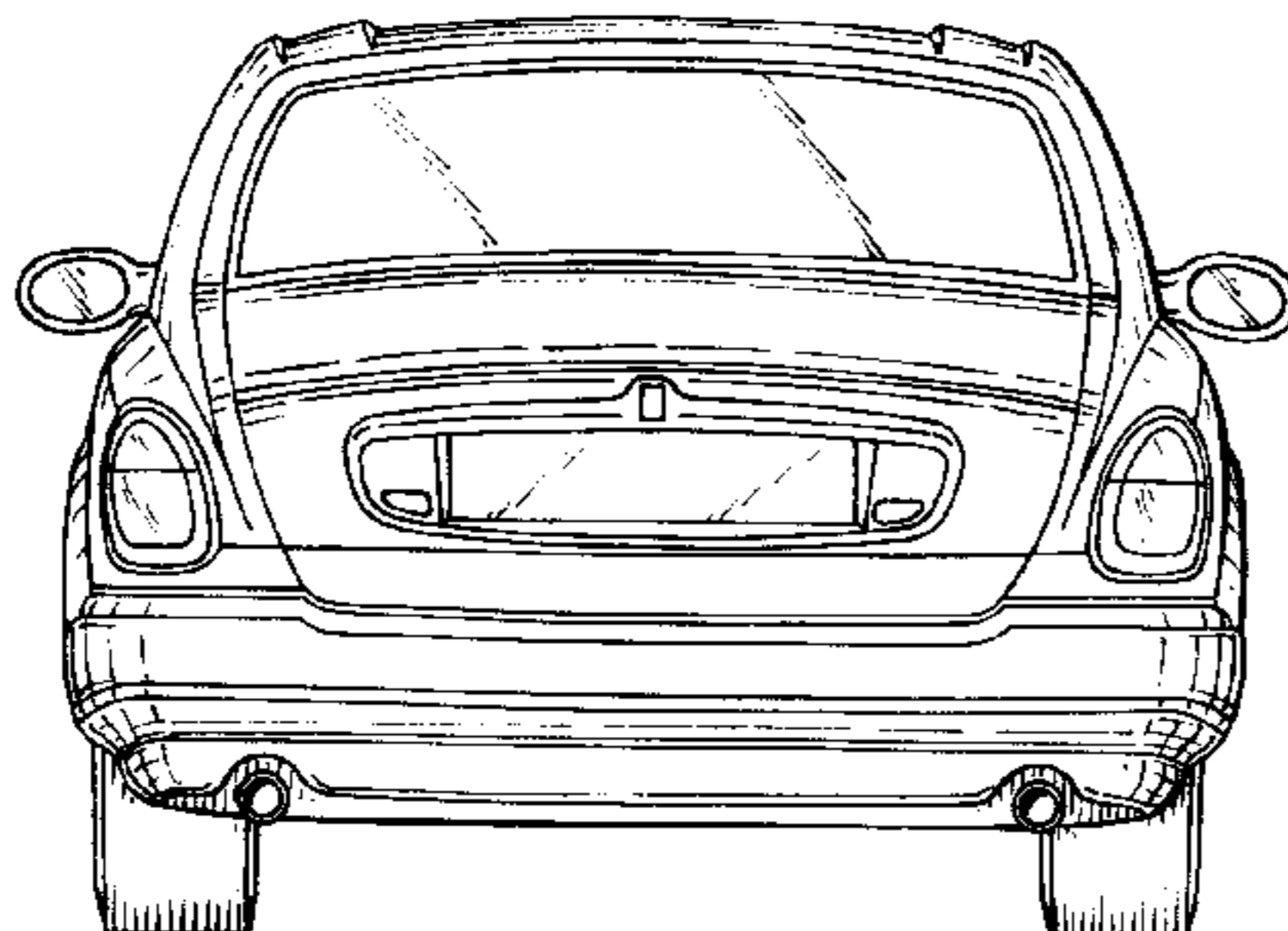
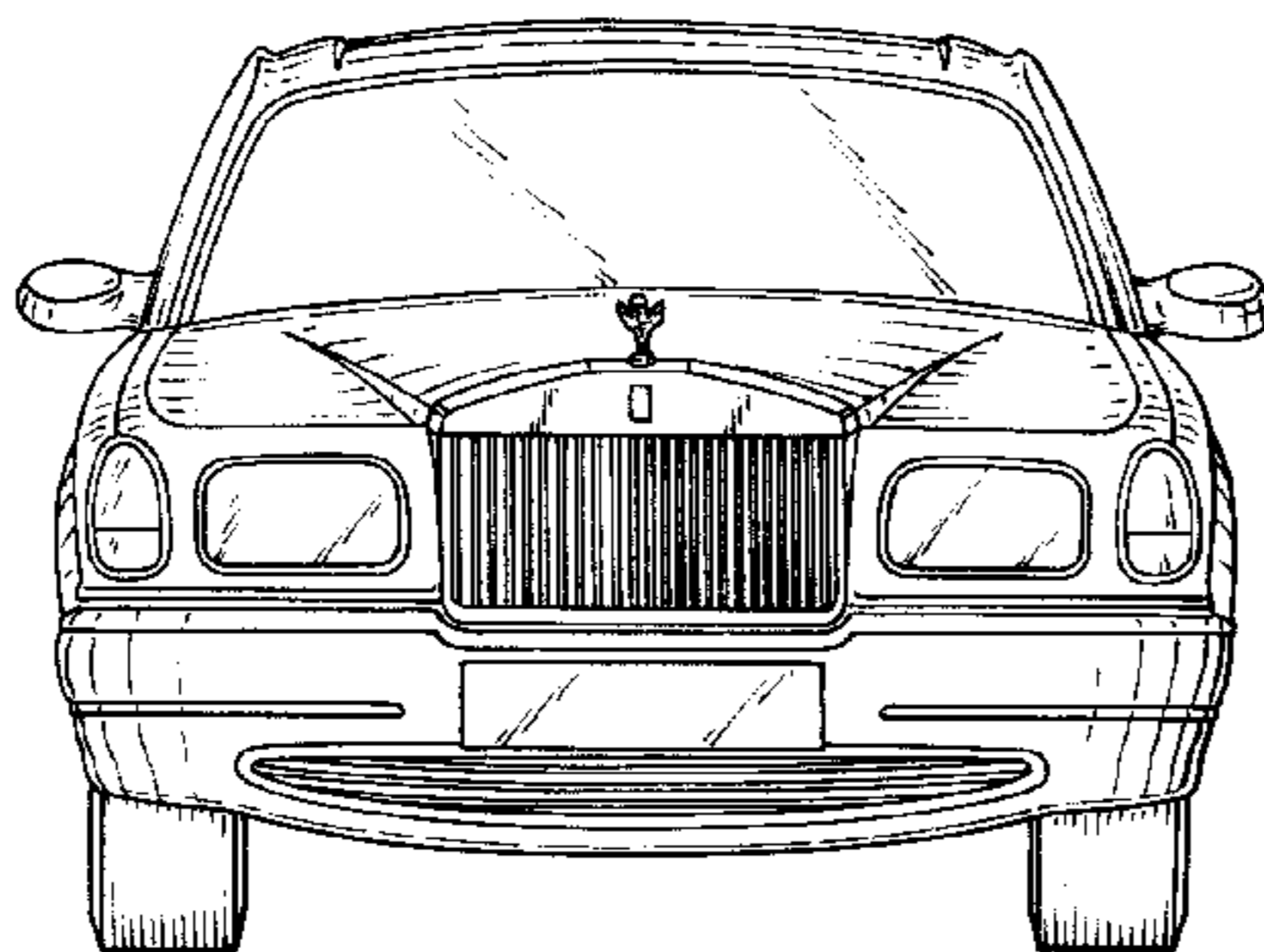

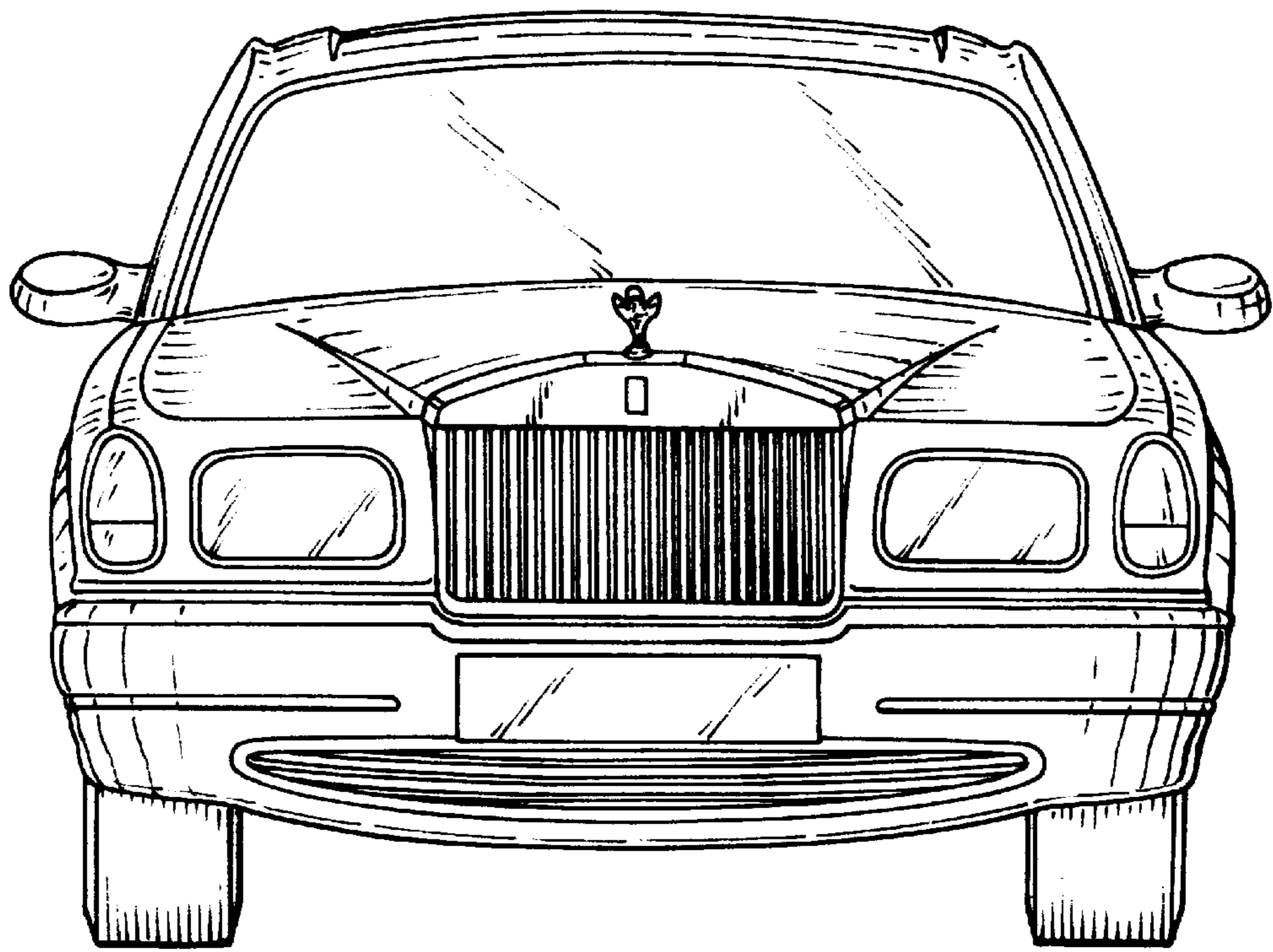

FIG. 1

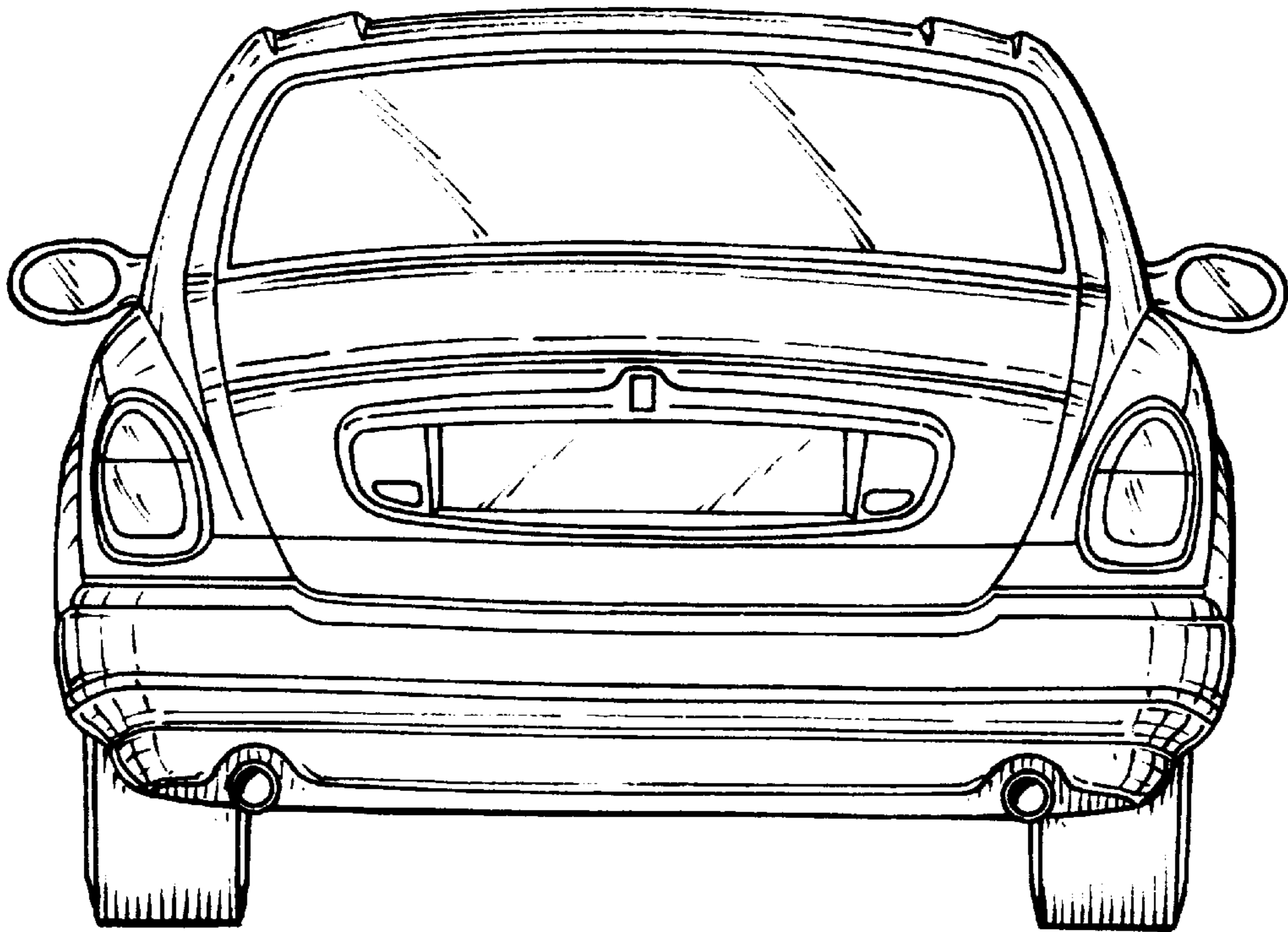

FIG. 2

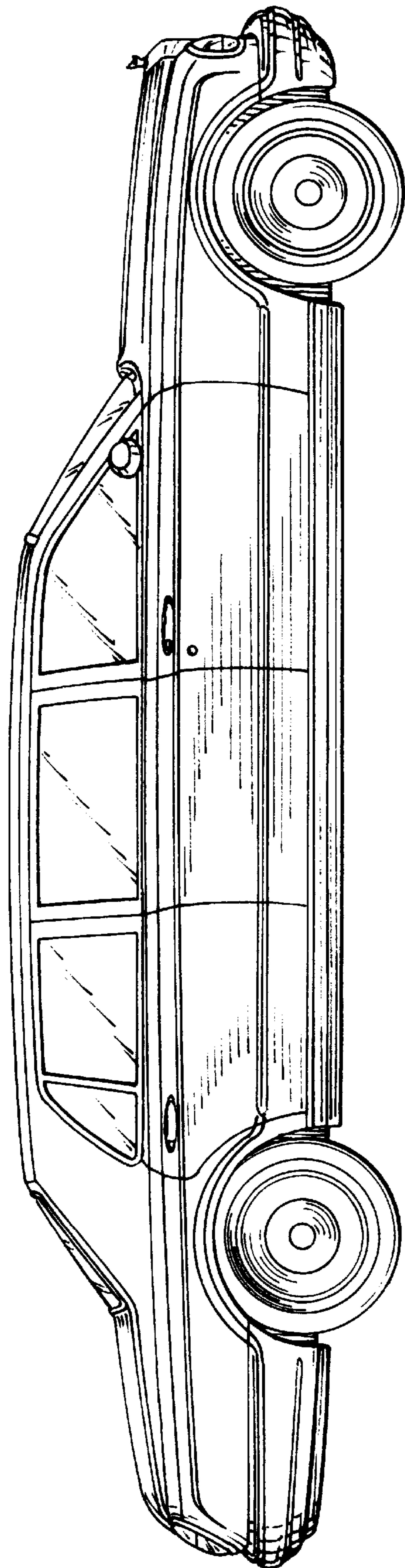

FIG. 3

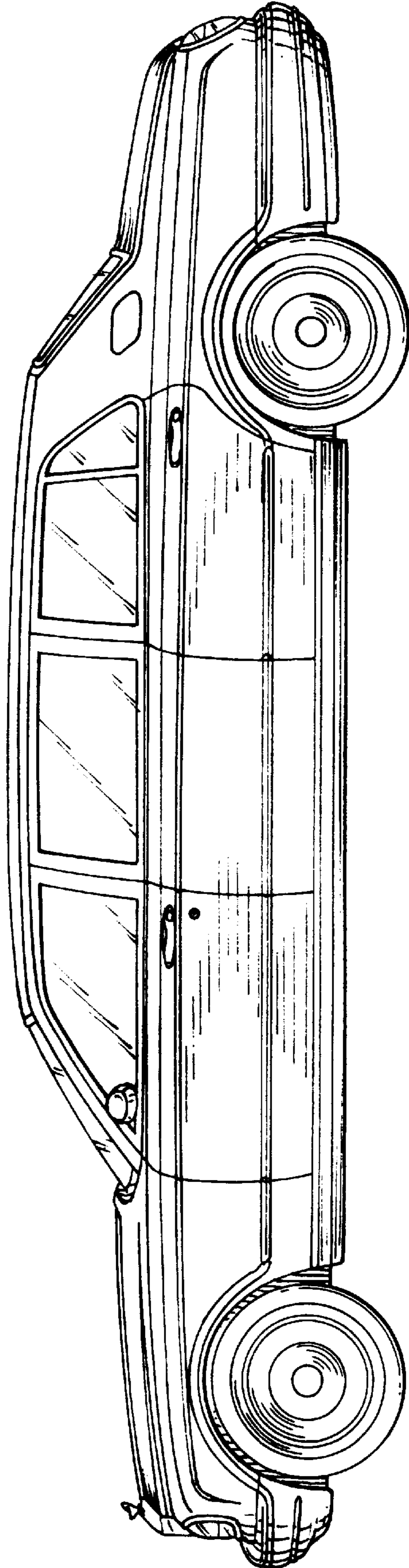
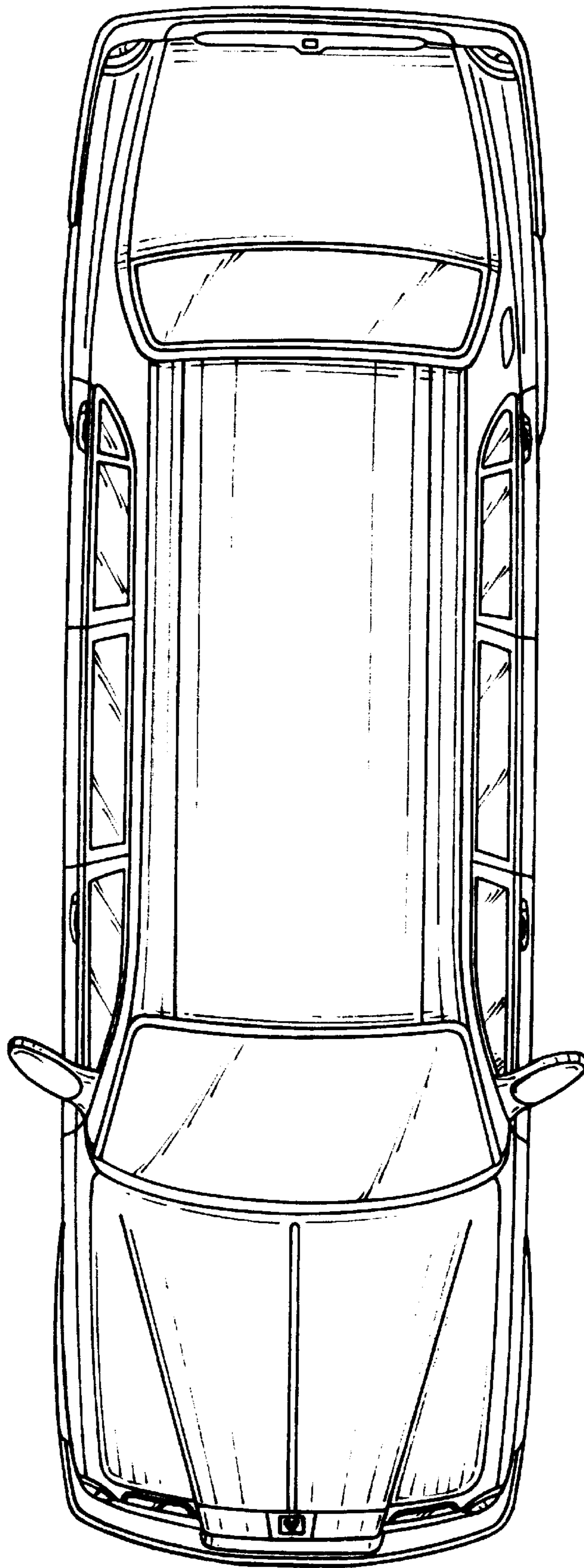

FIG. 4



TRUIS