



US00D402621S

# United States Patent [19] Douglas

[11] Patent Number: **Des. 402,621**

[45] Date of Patent: **\*\*Dec. 15, 1998**

[54] **VEHICLE COVER**

[76] Inventor: **Charles J. Douglas**, 30152-50th La. S,  
Auburn, Wash. 98001

[\*\*] Term: **14 Years**

[21] Appl. No.: **54,899**

[22] Filed: **May 24, 1996**

[51] **LOC (6) Cl.** ..... **12-16**

[52] **U.S. Cl.** ..... **D12/401**

[58] **Field of Search** ..... D12/400, 401,  
D12/402, 403, 404, 405; 150/166; 296/95.1,  
136, 97.7, 98; 160/370.2

[56] **References Cited**

**U.S. PATENT DOCUMENTS**

5,188,417	2/1993	Curchod	150/166 X
5,429,406	7/1995	Huang	150/166 X
5,435,362	7/1995	Chiang	150/166
5,456,515	10/1995	Dane	150/166 X
5,476,127	12/1995	Fournier	150/166

*Primary Examiner*—Doris V. Coles  
*Assistant Examiner*—Catherine R. Oliver  
*Attorney, Agent, or Firm*—Christensen O'Connor Johnson  
Kindness PLLC

[57] **CLAIM**

An ornamental design for a vehicle cover, as shown and described.

**DESCRIPTION**

FIG. 1 is a front perspective view of the vehicle cover showing my new design, with the broken lines on the vehicle cover representing top stitching;  
FIG. 2 is a front elevational view thereof;  
FIG. 3 is a rear elevational view thereof;  
FIG. 4 is a right side elevational view thereof;  
FIG. 5 is a left side elevational view thereof;  
FIG. 6 is a top plan view thereof; and,  
FIG. 7 is a bottom plan view.

The broken line showing of an automobile in FIG. 1 is for illustrative purposes only and forms no part of the claimed design.

**1 Claim, 4 Drawing Sheets**

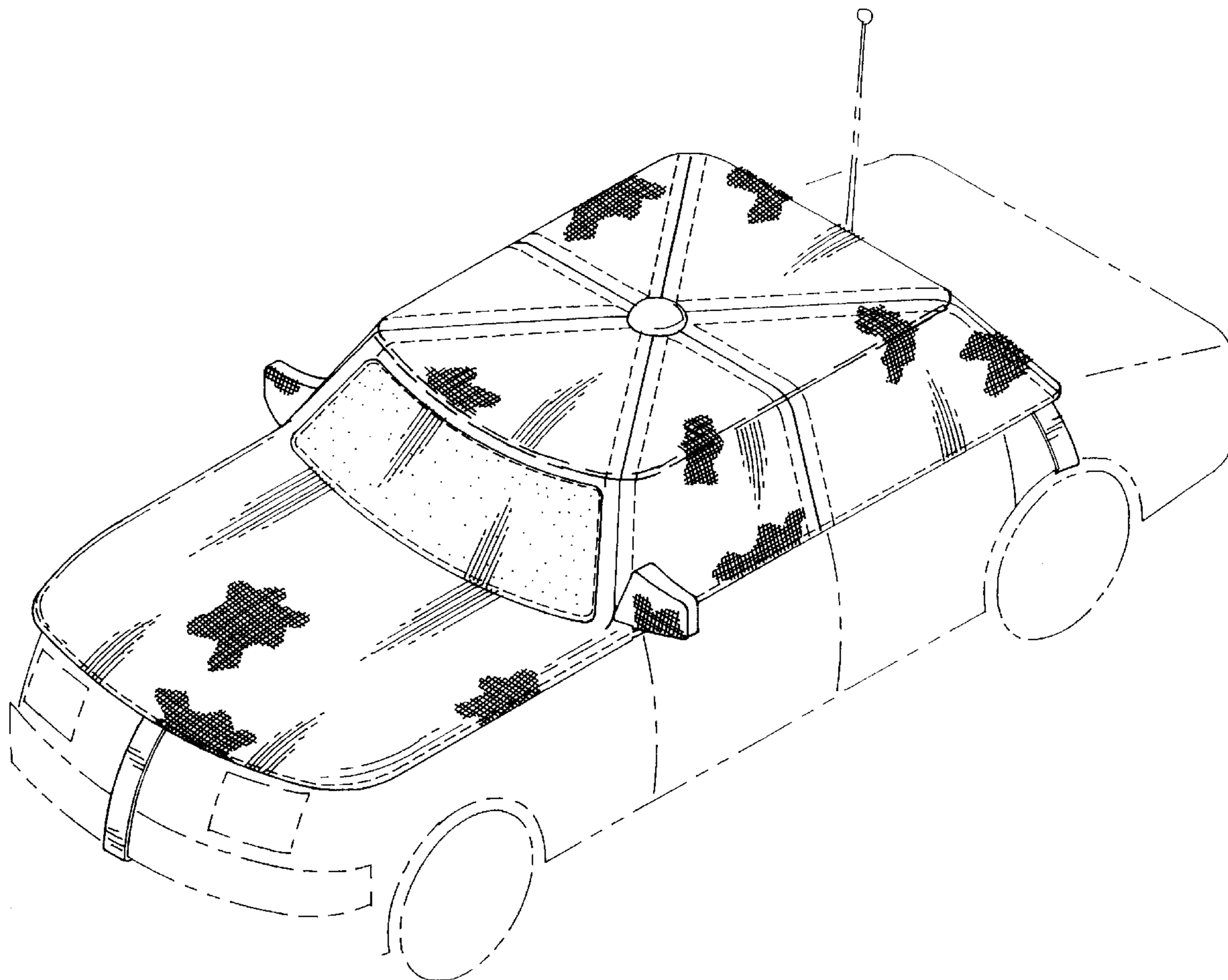

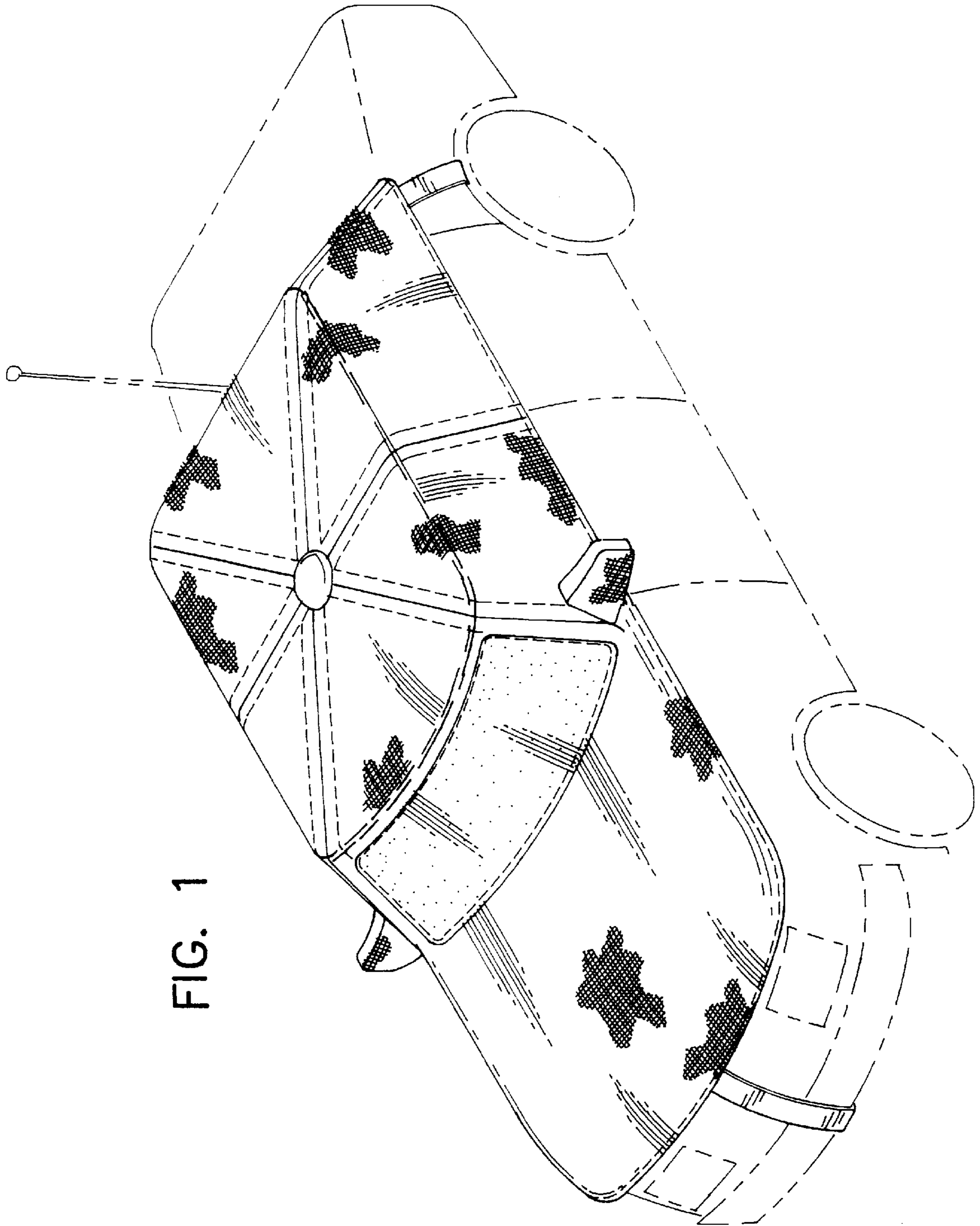

FIG. 1

FIG. 2

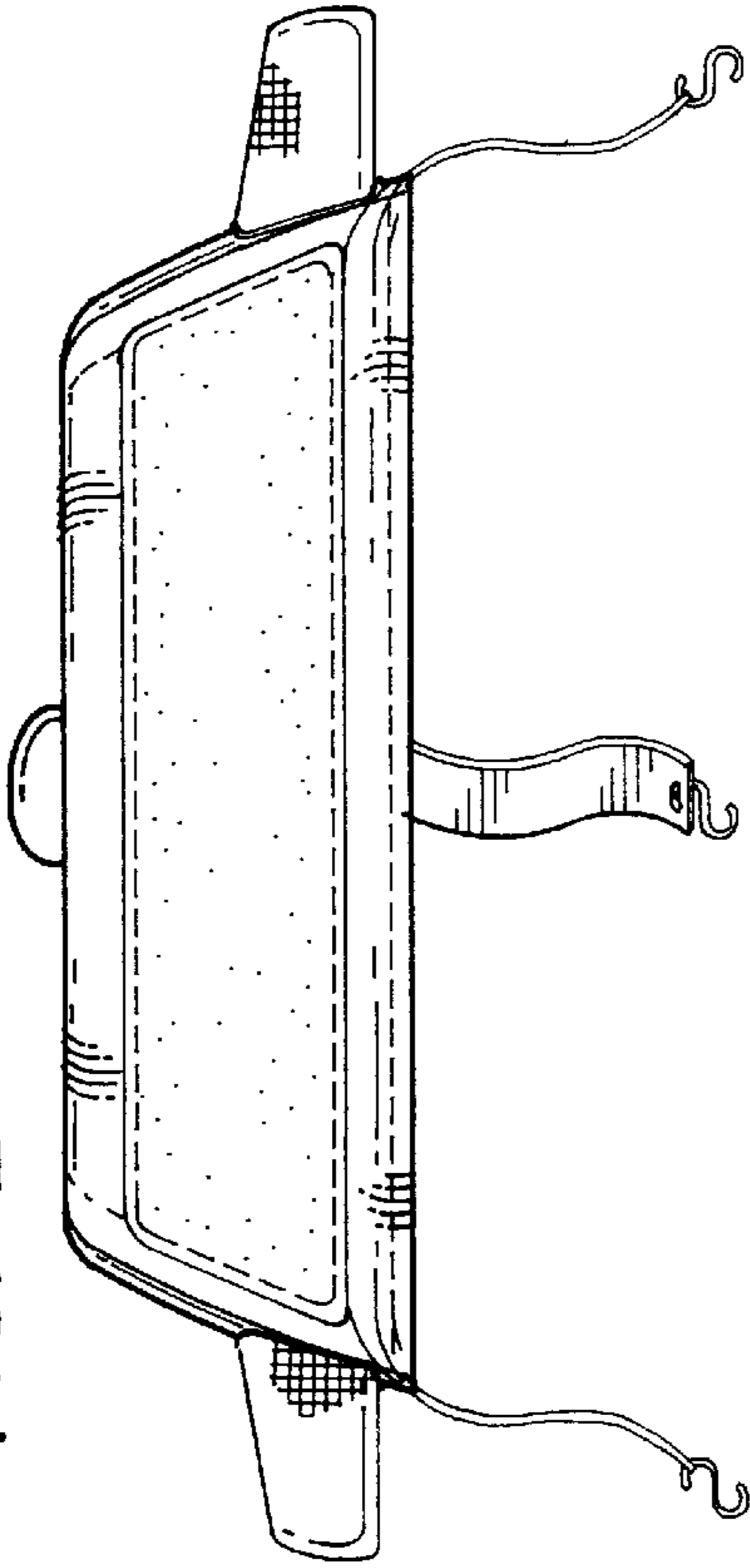

FIG. 3

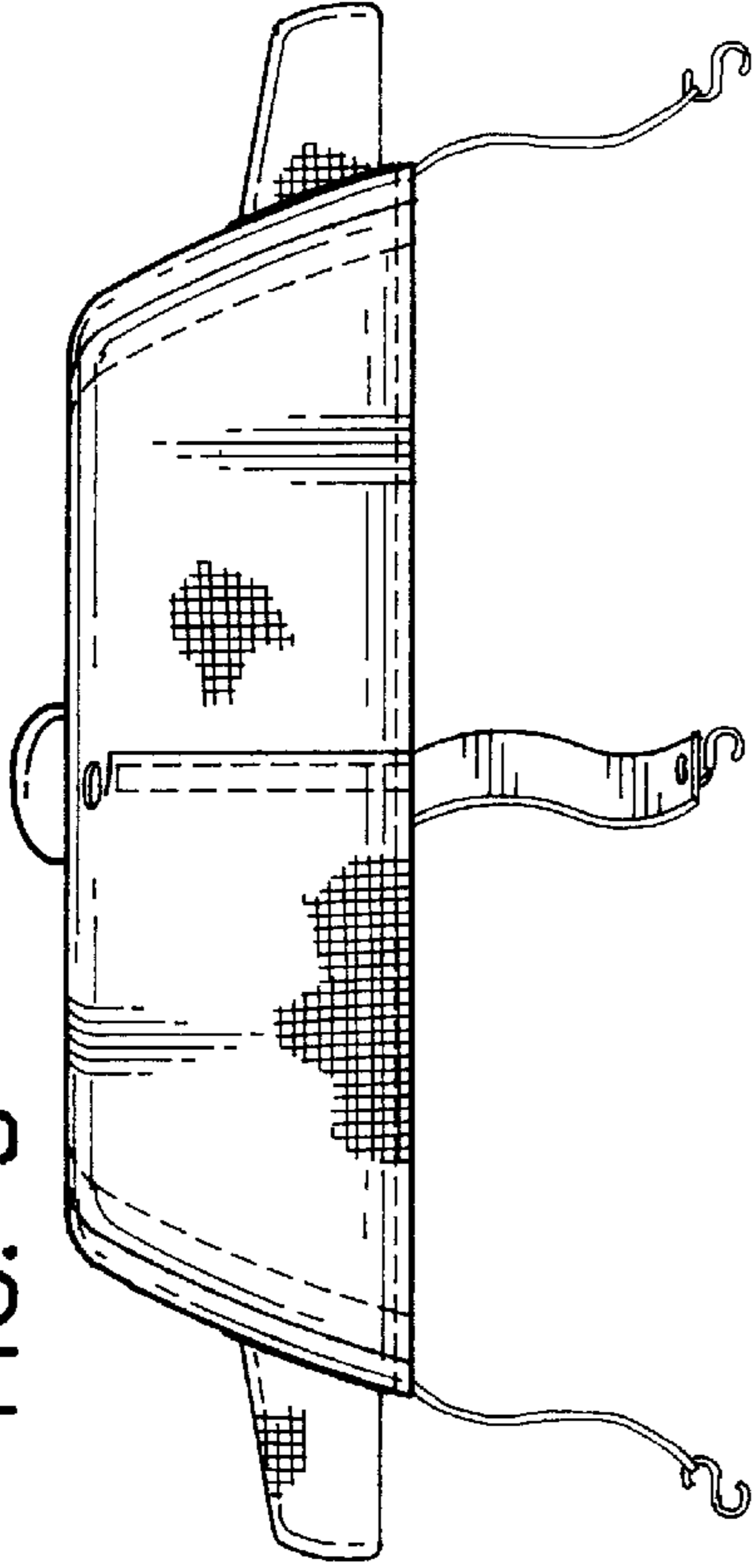

FIG. 4

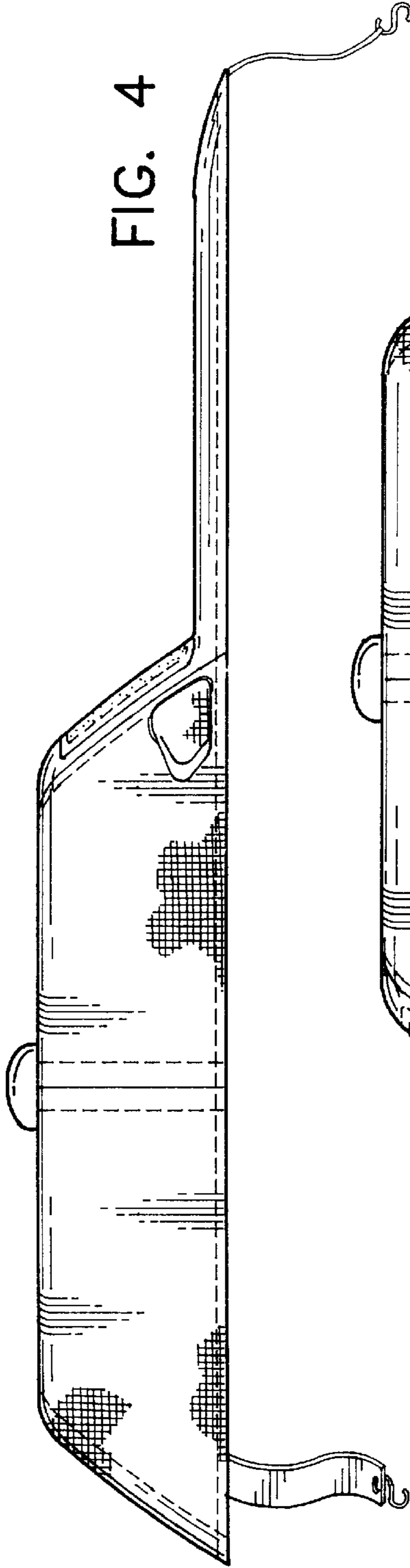
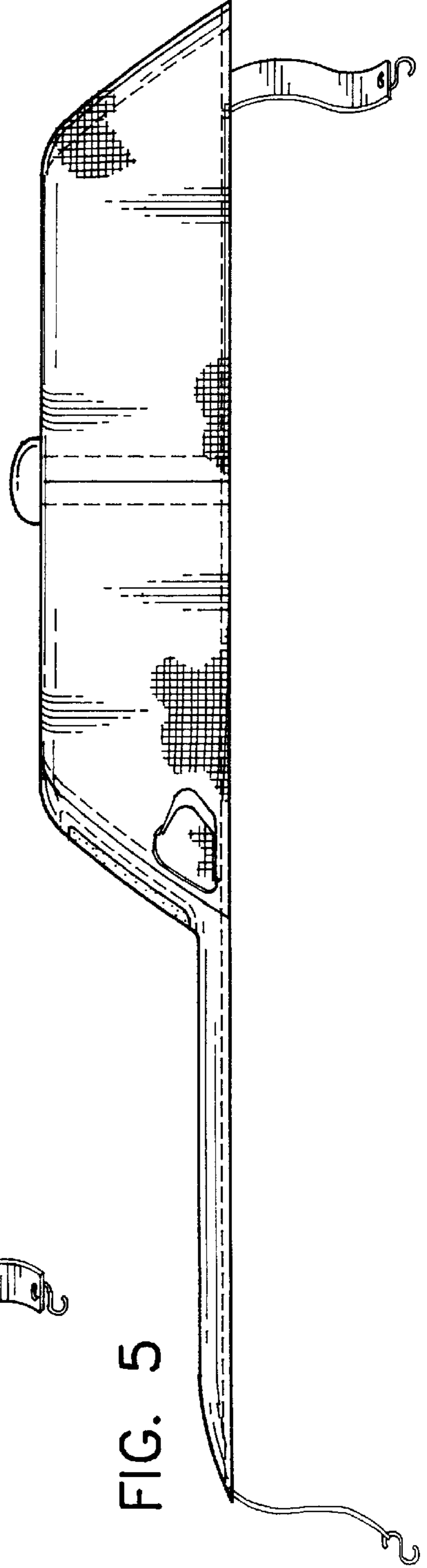

FIG. 5



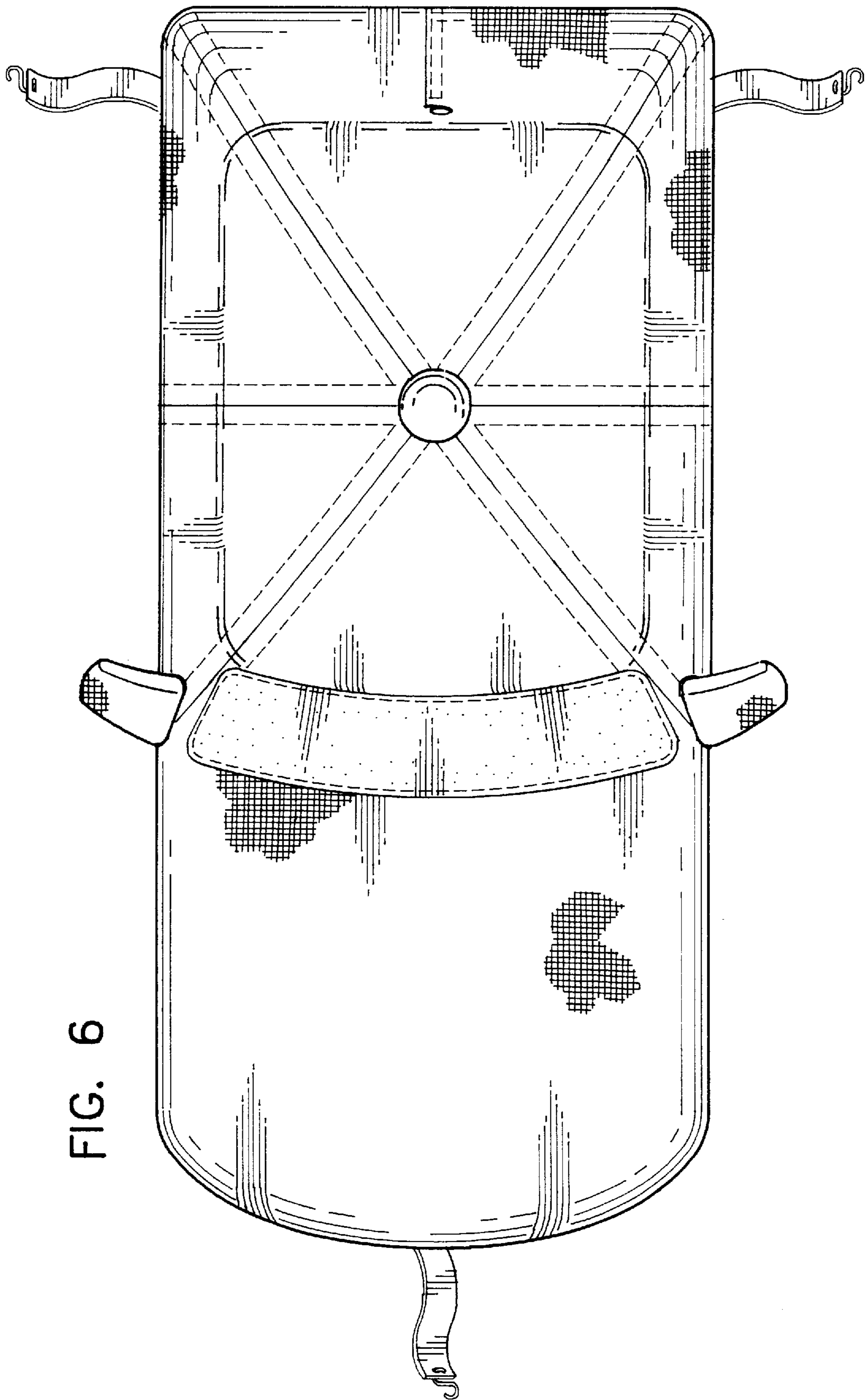

FIG. 6

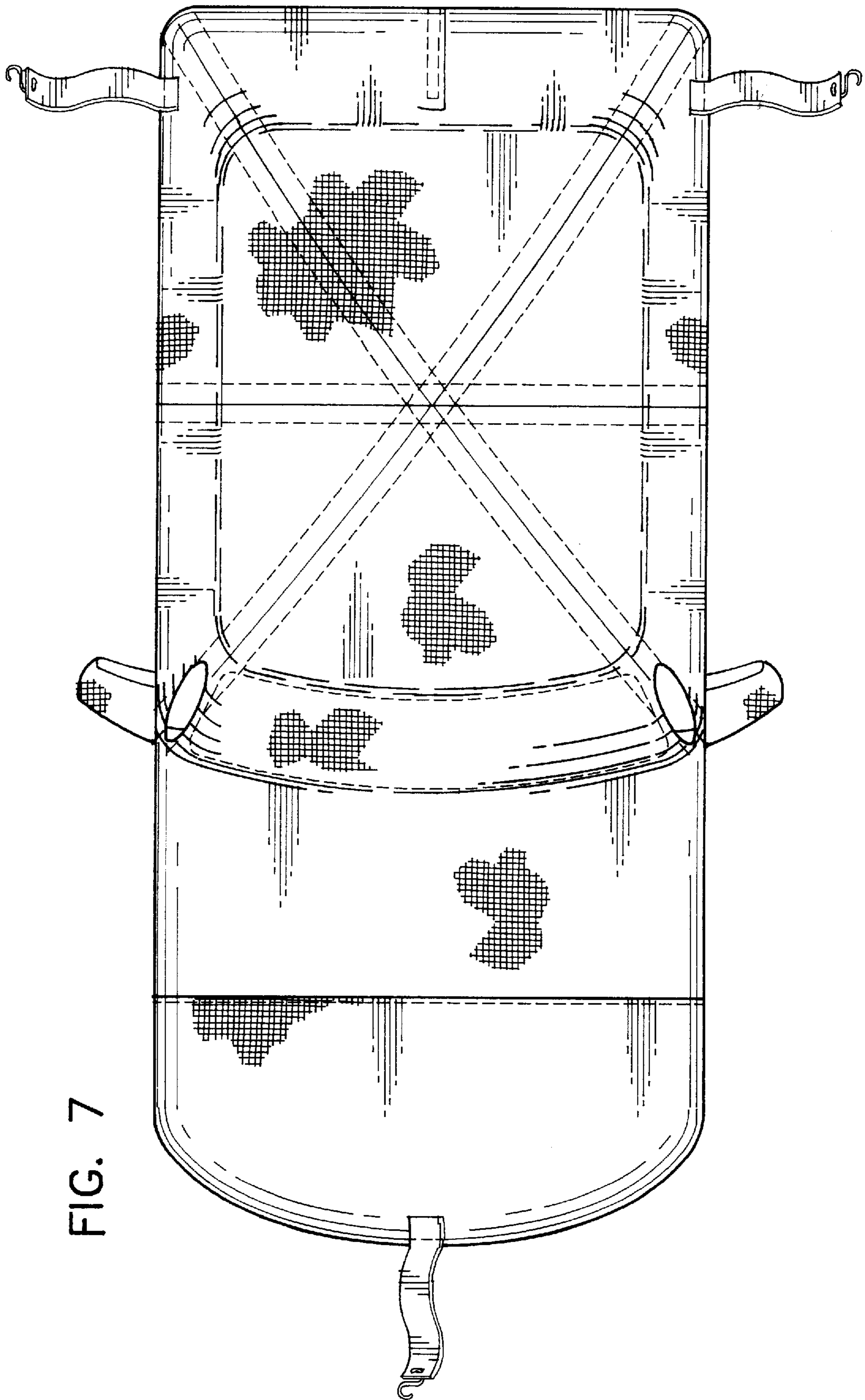

FIG. 7