



US00D402478S

# United States Patent [19]

Escobar et al.

[11] Patent Number: **Des. 402,478**

[45] Date of Patent: **\*\*Dec. 15, 1998**

## [54] THREE WAY COUCH

[76] Inventors: **Justo Escobar**, 11069 Glenwood Dr., Coral Springs, Fla. 33065; **Jane Bayles**, 1401 S. Ocean Dr., Ft. Lauderdale, Fla. 33316

[\*\*] Term: **14 Years**

[21] Appl. No.: **69,594**

[22] Filed: **Apr. 30, 1997**

### Related U.S. Application Data

[63] Continuation of Ser. No. 717,217, Sep. 26, 1996, abandoned.

[51] **LOC (6) Cl.** ..... **06-01**

[52] **U.S. Cl.** ..... **D6/335; D6/336; D6/381**

[58] **Field of Search** ..... D6/334, 335, 336, D6/364, 371, 373, 381, 500, 501, 502; 5/12.1, 14, 17, 18.1; 297/232

### [56] References Cited

#### U.S. PATENT DOCUMENTS

D. 217,963	7/1970	Rozett	.....	D6/336
D. 253,263	10/1979	Long	.....	D6/371
D. 257,454	10/1980	Nash	.....	D6/364
D. 258,627	3/1981	Halme	.....	D6/371
D. 283,562	4/1986	Raftery	.....	D6/334
4,067,073	1/1978	Komarov	.	
4,166,299	9/1979	DuShane et al.	.	
4,343,054	8/1982	Kane	.	
5,038,421	8/1991	Harris	.	
5,329,654	7/1994	Sherman	.	

## FOREIGN PATENT DOCUMENTS

838358 5/1952 Germany .

## OTHER PUBLICATIONS

Design Catalog, p. 21, Chair Shown, Mar. 1980.

Gretchen Bellinger ad, Sofa Shown.

This End Up Catalog, p. 16, Day Bed at Bottom, Nov. 1994.

*Primary Examiner*—Gary D. Watson

*Attorney, Agent, or Firm*—Morgan & Finnegan LLP

## [57] CLAIM

The ornamental design for a three way couch, as shown and described.

## DESCRIPTION

FIG. 1 is a perspective view of the ornamental appearance of a couch in accordance with the present invention;

FIG. 2 is another perspective view of the ornamental appearance of the couch of FIG. 1 as converted to a double bed, wherein the backrest pillows have been removed for ease of illustration;

FIG. 3 is a front view of the ornamental appearance of the couch of FIG. 1;

FIG. 4 is a top view of the ornamental appearance of the couch of FIG. 1;

FIG. 5 is an end view of the ornamental appearance of the couch of FIG. 1, wherein the opposite end of the couch is a mirror image of the view depicted in FIG. 5; and,

FIG. 6 is an end view of the ornamental appearance of the couch of FIG. 2 as converted to a double bed.

The rear view of the three way couch forms no part of the claimed design.

**1 Claim, 4 Drawing Sheets**

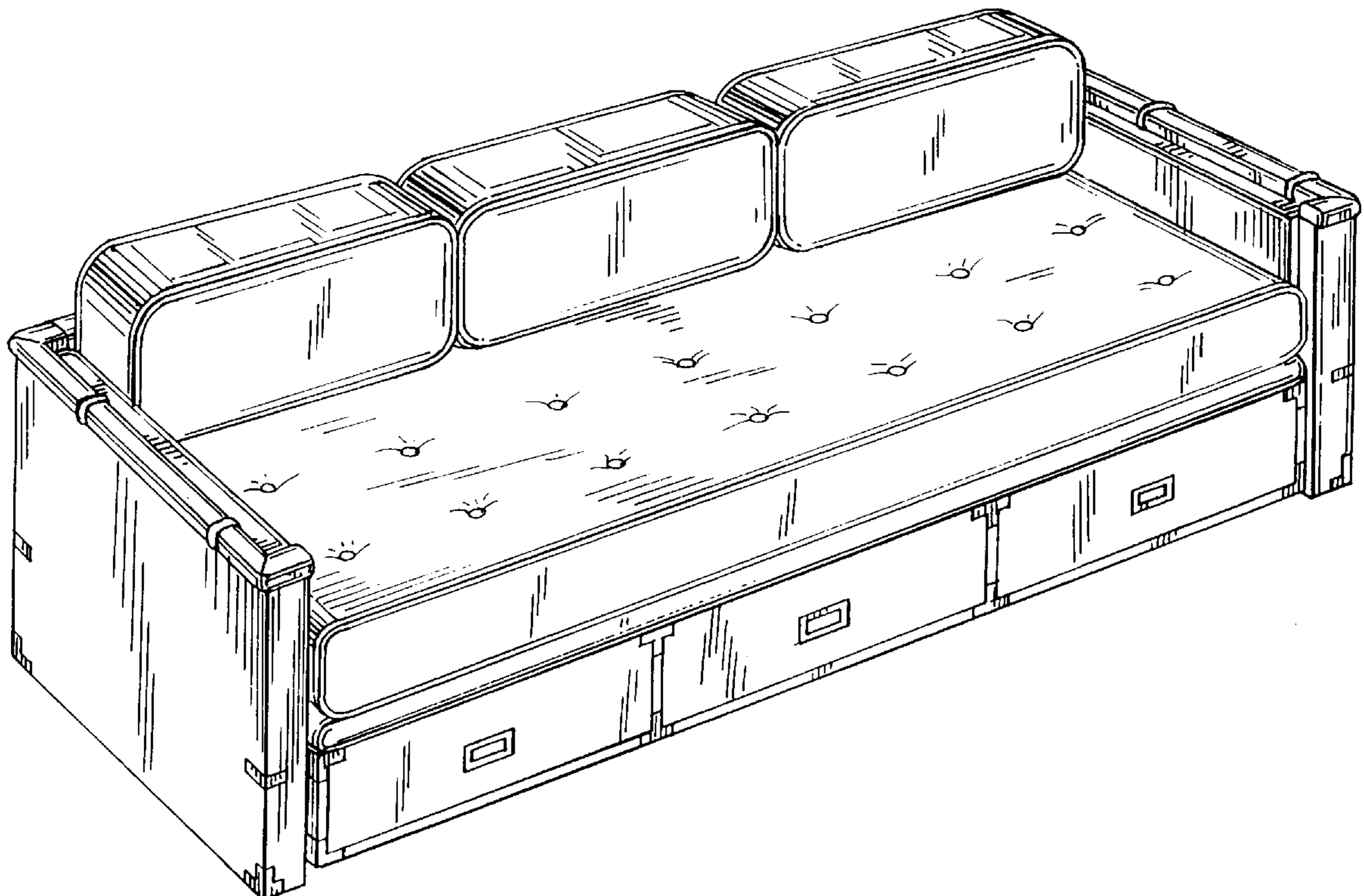

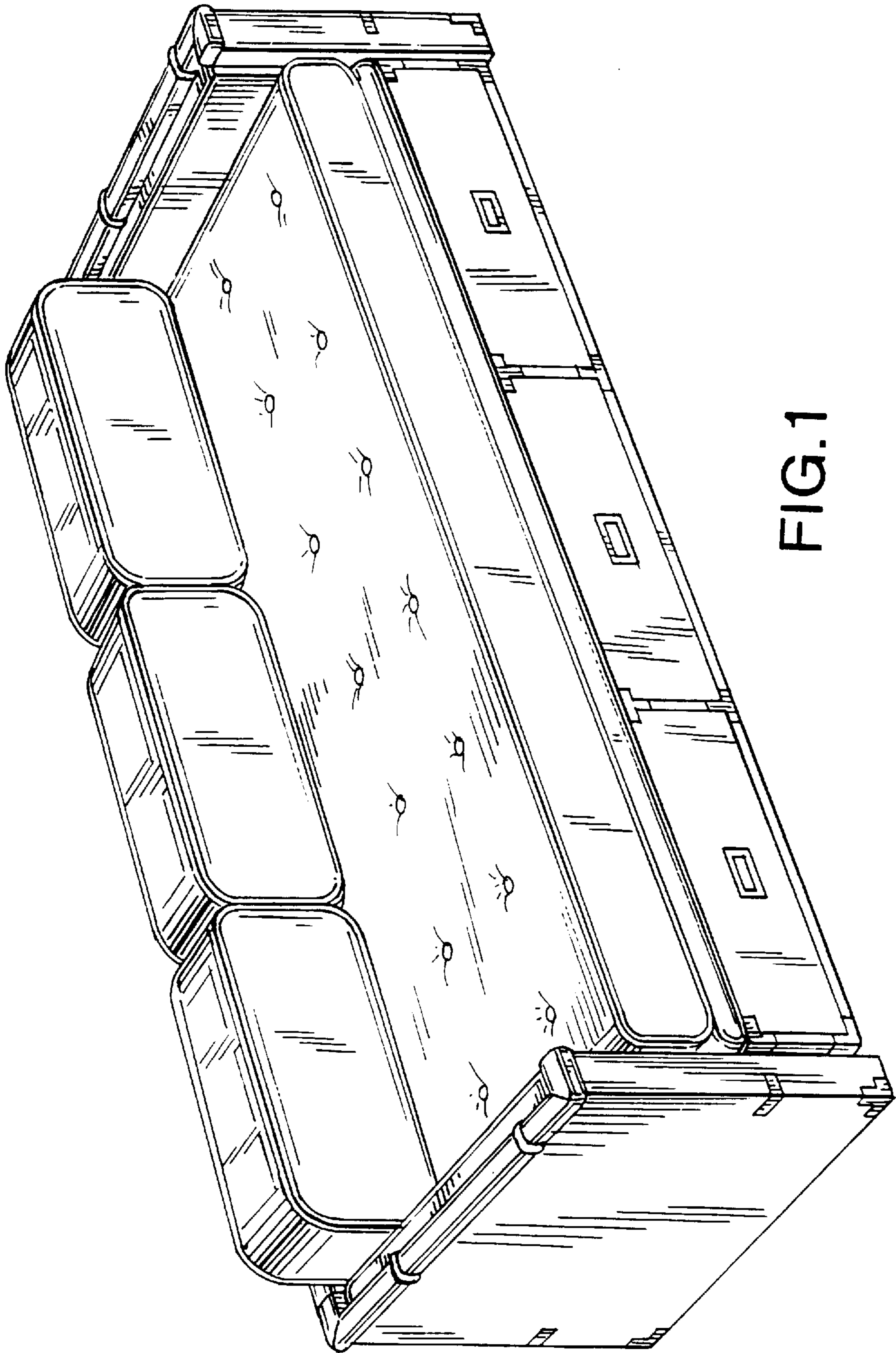

FIG. 1

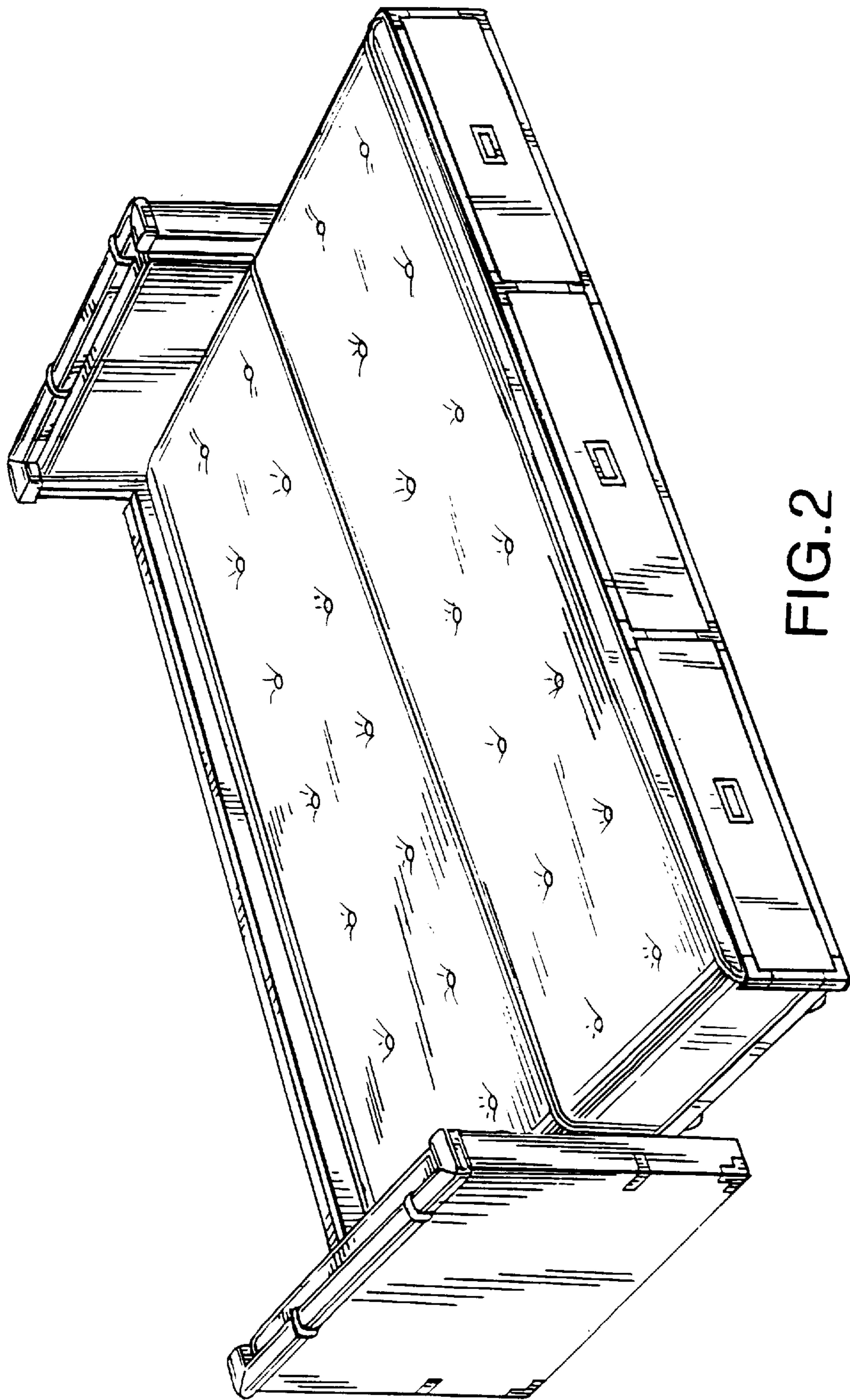

FIG.2

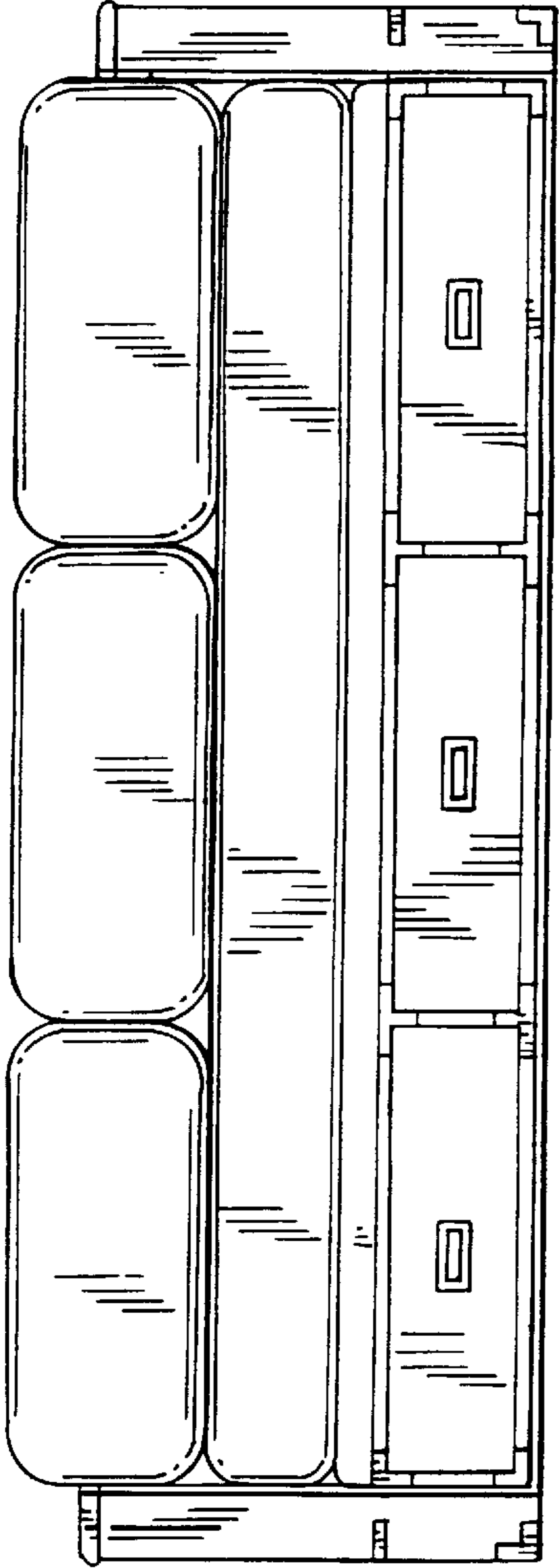

FIG. 3

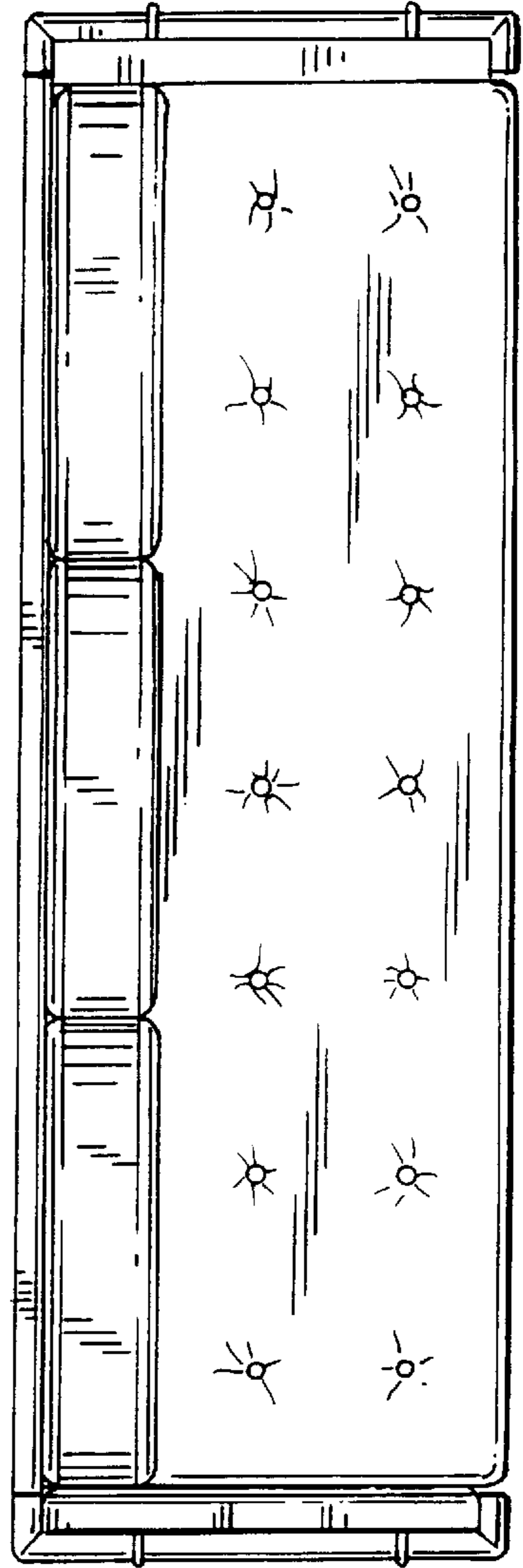

FIG. 4

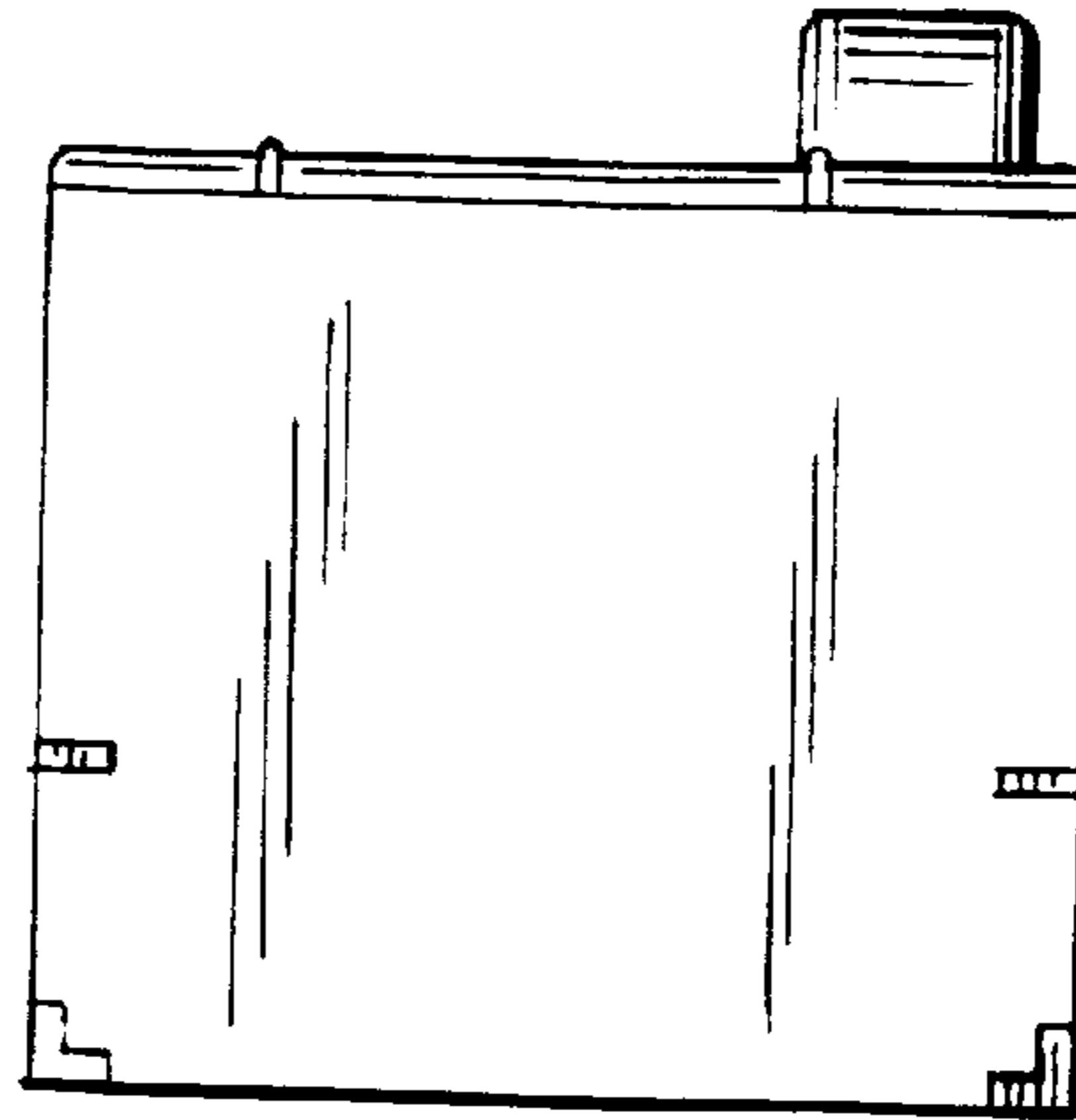

FIG. 5

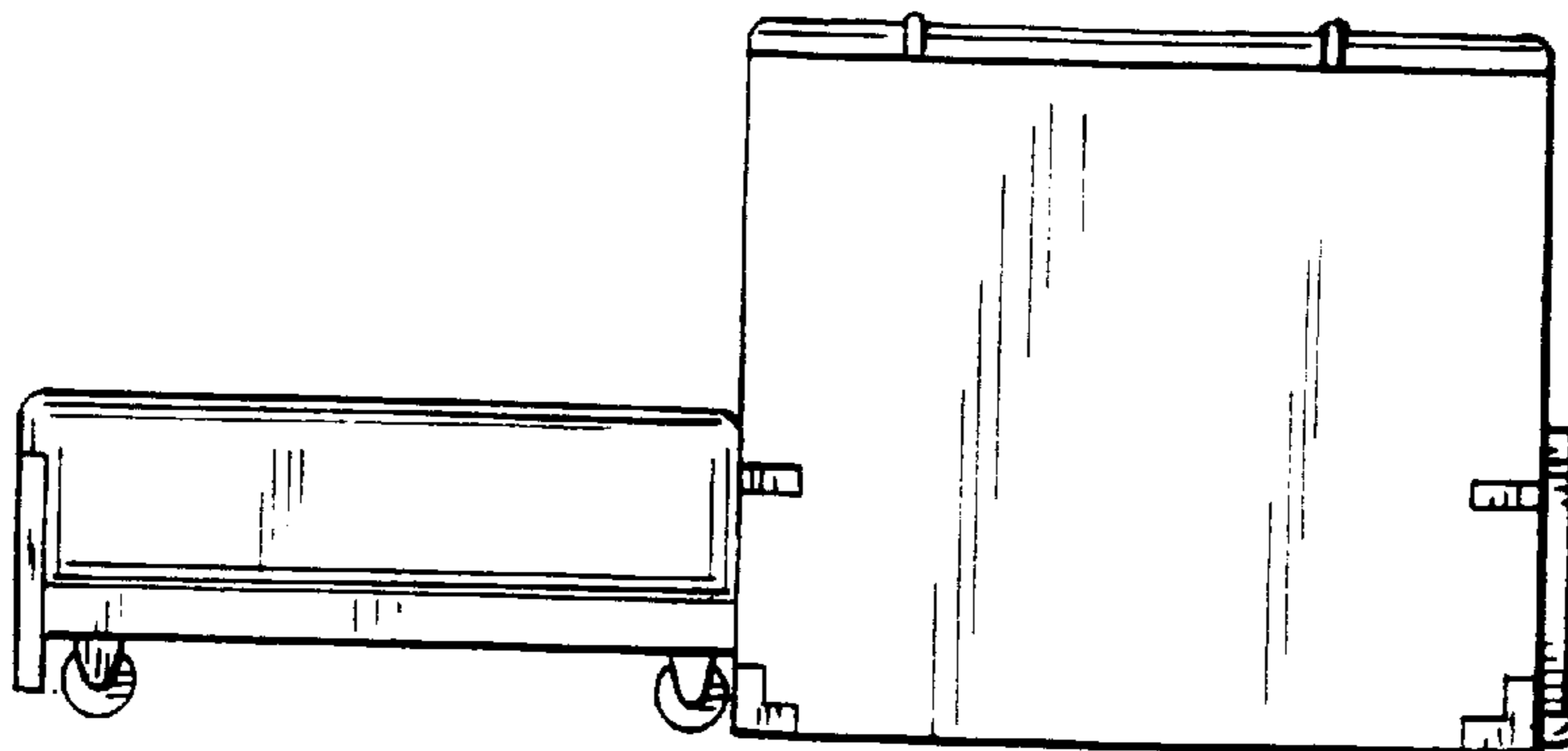

FIG. 6