



US00D402215S

United States Patent [19] Fitzgibbon

[11] **Patent Number: Des. 402,215**

[45] **Date of Patent: **Dec. 8, 1998**

[54] **AUTOMOBILE FRAME ENGAGING HOOK**

[76] Inventor: **Henry J. Fitzgibbon**, 960 Railroad Ave., Winter Park, Fla. 32789

[**] Term: **14 Years**

[21] Appl. No.: **73,623**

[22] Filed: **Jul. 11, 1997**

[51] **LOC (6) Cl. 10-04**

[52] **U.S. Cl. D10/65**

[58] **Field of Search D10/46, 61, 64, D10/65, 70; D15/199; 33/600, 533, 608, 286, 288; 72/422, 447**

[56] **References Cited**

U.S. PATENT DOCUMENTS

D. 317,573	6/1991	Step	D10/64
3,690,712	9/1972	Bahrman	294/82 R
3,818,750	6/1974	Ballweber	72/476
4,167,108	9/1979	Jarman et al.	72/477
4,530,232	7/1985	Smith	72/447

4,815,719	3/1989	Peters et al.	269/130
4,941,343	7/1990	Stancato	72/447
5,044,191	9/1991	Combs	72/422
5,335,533	8/1994	Rehus	72/422

Primary Examiner—Antoine Duval Davis
Attorney, Agent, or Firm—William M. Hobby, III

[57] **CLAIM**

The ornamental design for an automobile frame engaging hook, as shown and described.

DESCRIPTION

FIG. 1 is a top rear perspective view of my new automobile frame engaging hook;
FIG. 2 is a rear elevation;
FIG. 3 is a front elevation;
FIG. 4 is a top plan view;
FIG. 5 is a bottom plan view;
FIG. 6 is a left side elevation; and,
FIG. 7 is a right side elevation.

1 Claim, 1 Drawing Sheet

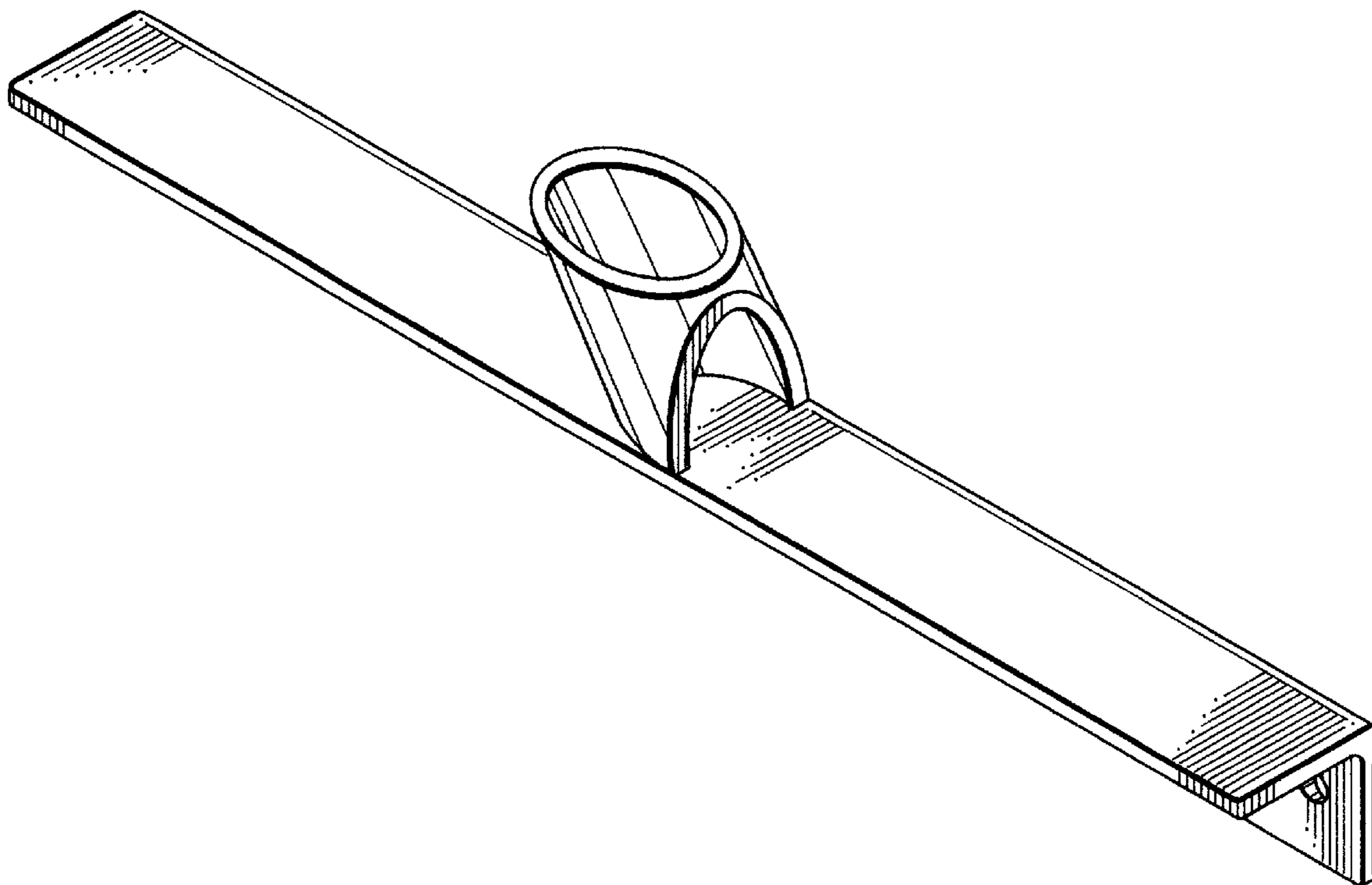

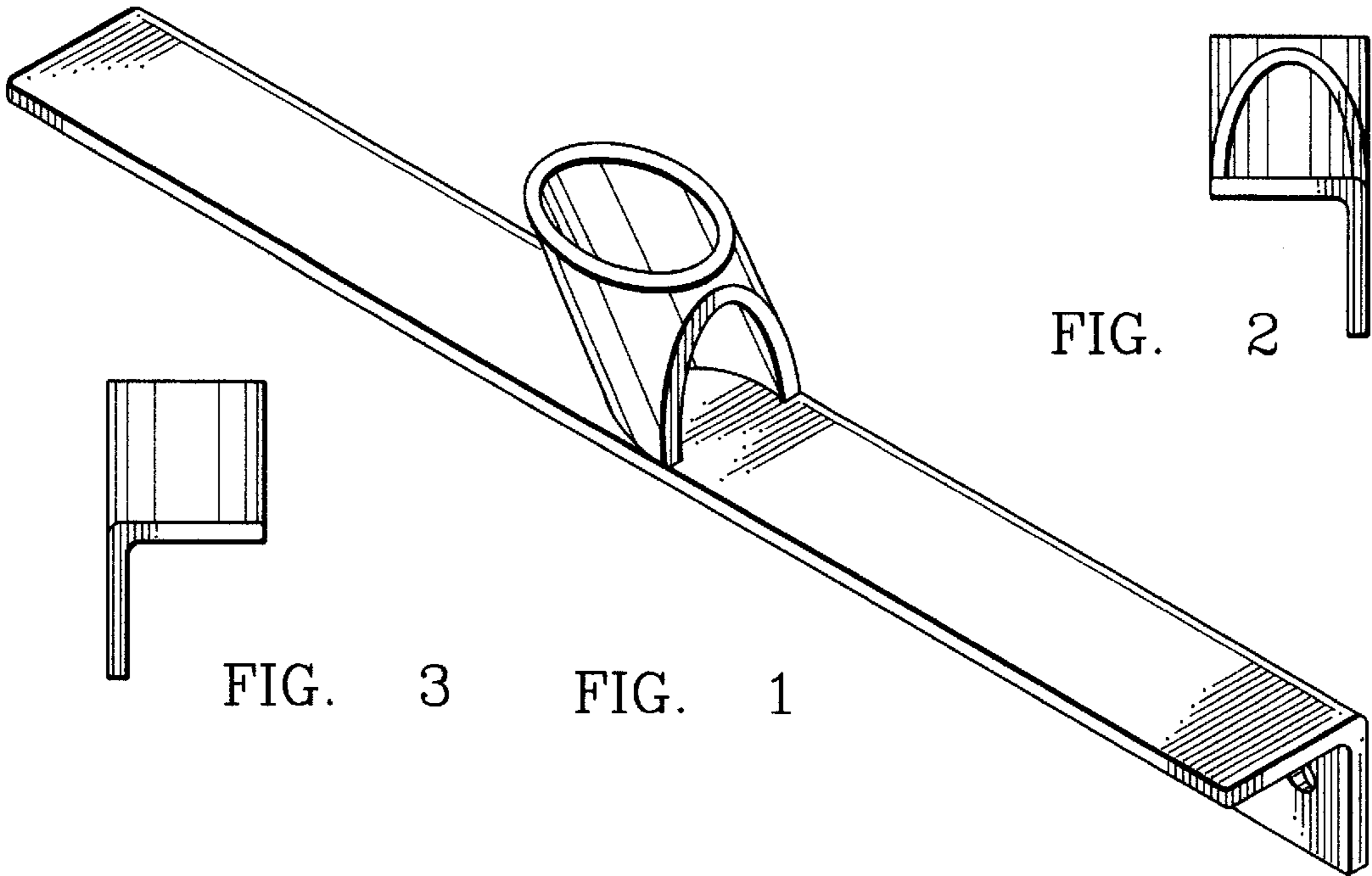

FIG. 3

FIG. 1

FIG. 2

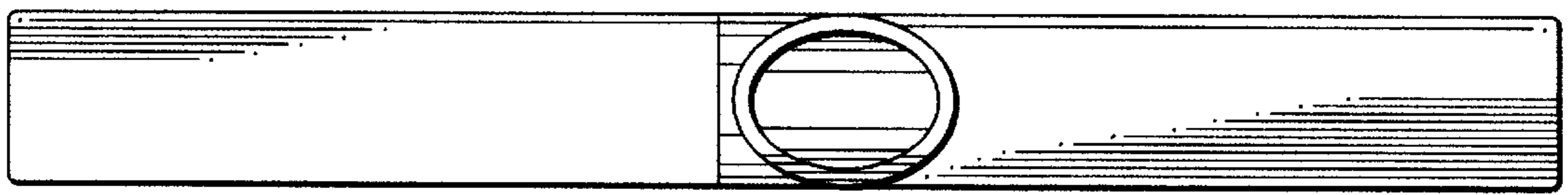

FIG. 4

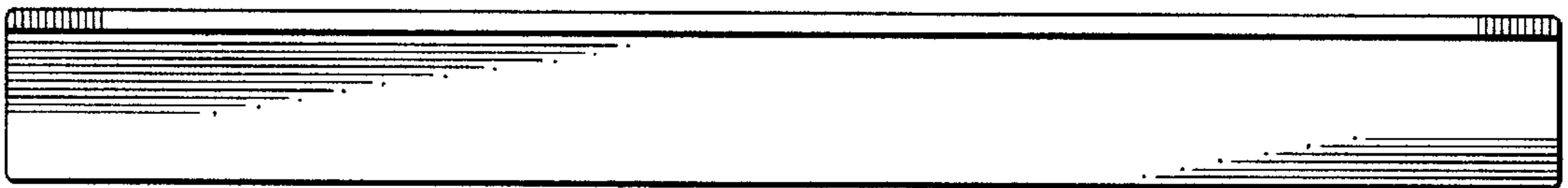

FIG. 5

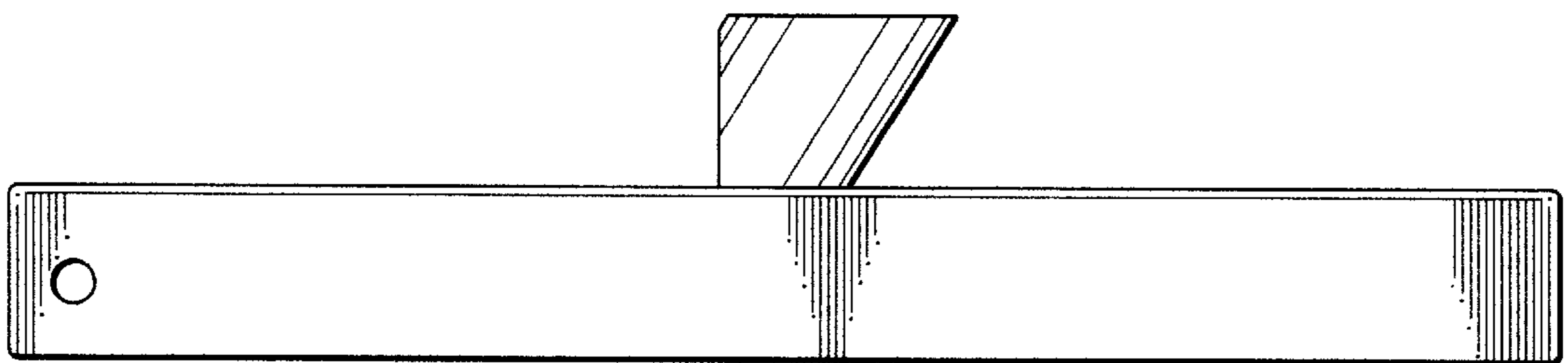

FIG. 6

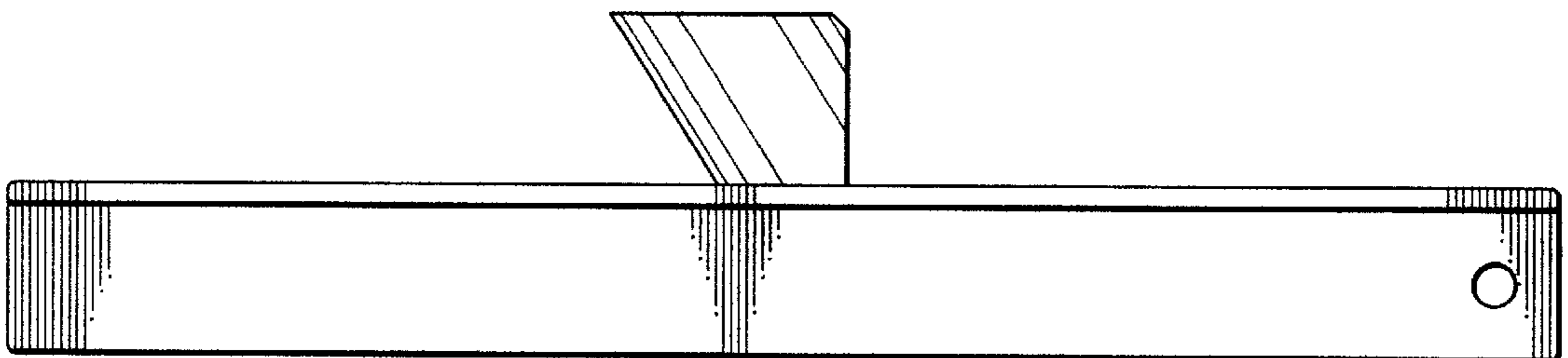

FIG. 7