



US00D401731S

United States Patent [19]

Jeruss

[11] **Patent Number: Des. 401,731**

[45] **Date of Patent: **Nov. 24, 1998**

[54] **RAMP FOR LOADING AND UNLOADING TRUCKS**

[76] Inventor: **Paul L. Jeruss**, 2626 Lucile Ave., Stockton, Calif. 95209

[**] Term: **14 Years**

[21] Appl. No.: **67,120**

[22] Filed: **Feb. 25, 1997**

[51] **LOC (6) Cl.** **12-05**

[52] **U.S. Cl.** **D34/32**

[58] **Field of Search** D34/32; 52/175-176; 14/69.5, 71.1

[56] **References Cited**

U.S. PATENT DOCUMENTS

D. 360,729	7/1995	Collins	D34/32
5,001,798	3/1991	Hamilton	14/69.5
5,553,989	9/1996	Ullman	14/71.1

Primary Examiner—Doris Clark
Attorney, Agent, or Firm—Lothrop & West

[57] **CLAIM**

The ornamental design for a ramp for loading and unloading trucks, as shown and described.

DESCRIPTION

FIG. 1 is a left front perspective of a ramp for loading and unloading trucks, showing my new design;
 FIG. 2 is a side elevational view thereof, the opposite side elevational view being substantially a mirror image, thereof;
 FIG. 3 is a front elevational view, thereof;
 FIG. 4 is a rear elevational view thereof;
 FIG. 5 is a side elevational view thereof, showing the lower portion of the ramp folded upwardly, into an alternative position;
 FIG. 6 is a top plan view thereof; and,
 FIG. 7 is a bottom plan view, thereof.

The broken line representation of the grid structure shown in FIGS. 1, 3, 4, 6 and 7 forms no part of the claimed design. The broken line representation of grade level of the ground and the rear end of the truck trailer shown in FIG. 2, are included solely for illustrative purposes, forming no part of the claimed design.

1 Claim, 2 Drawing Sheets

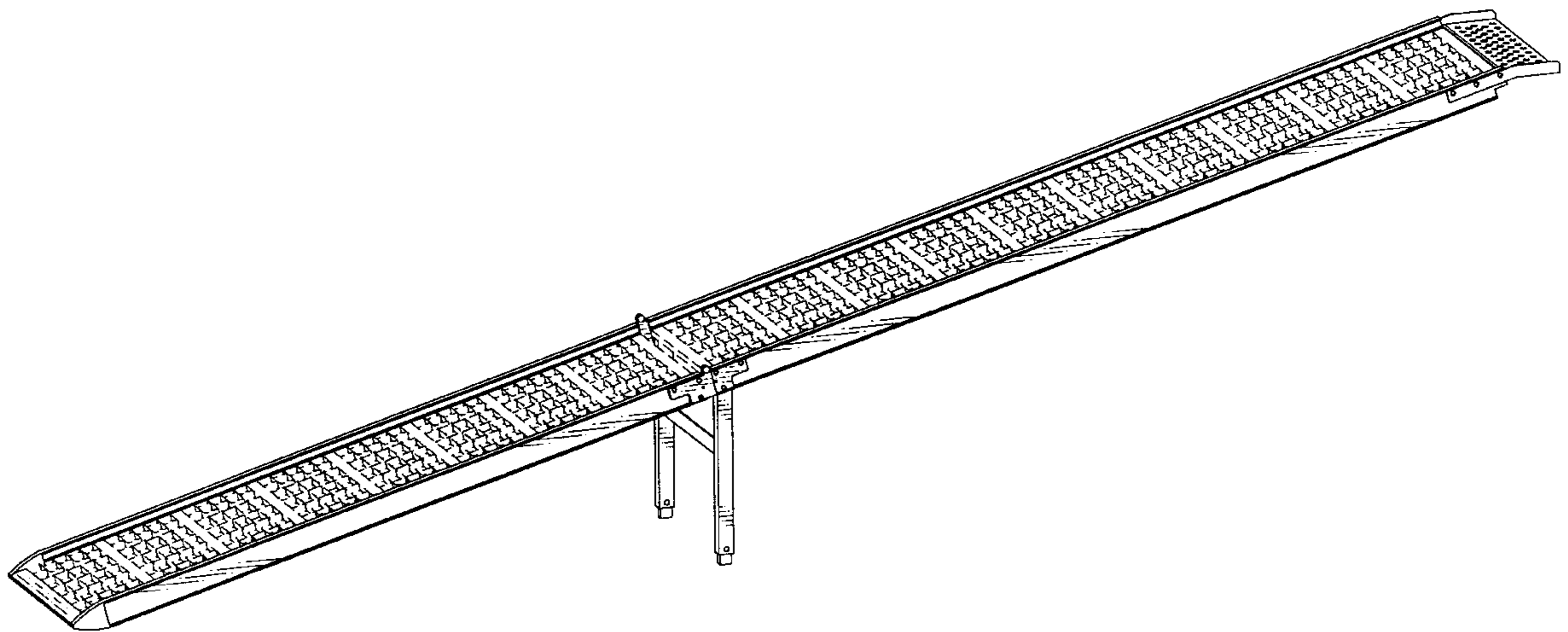

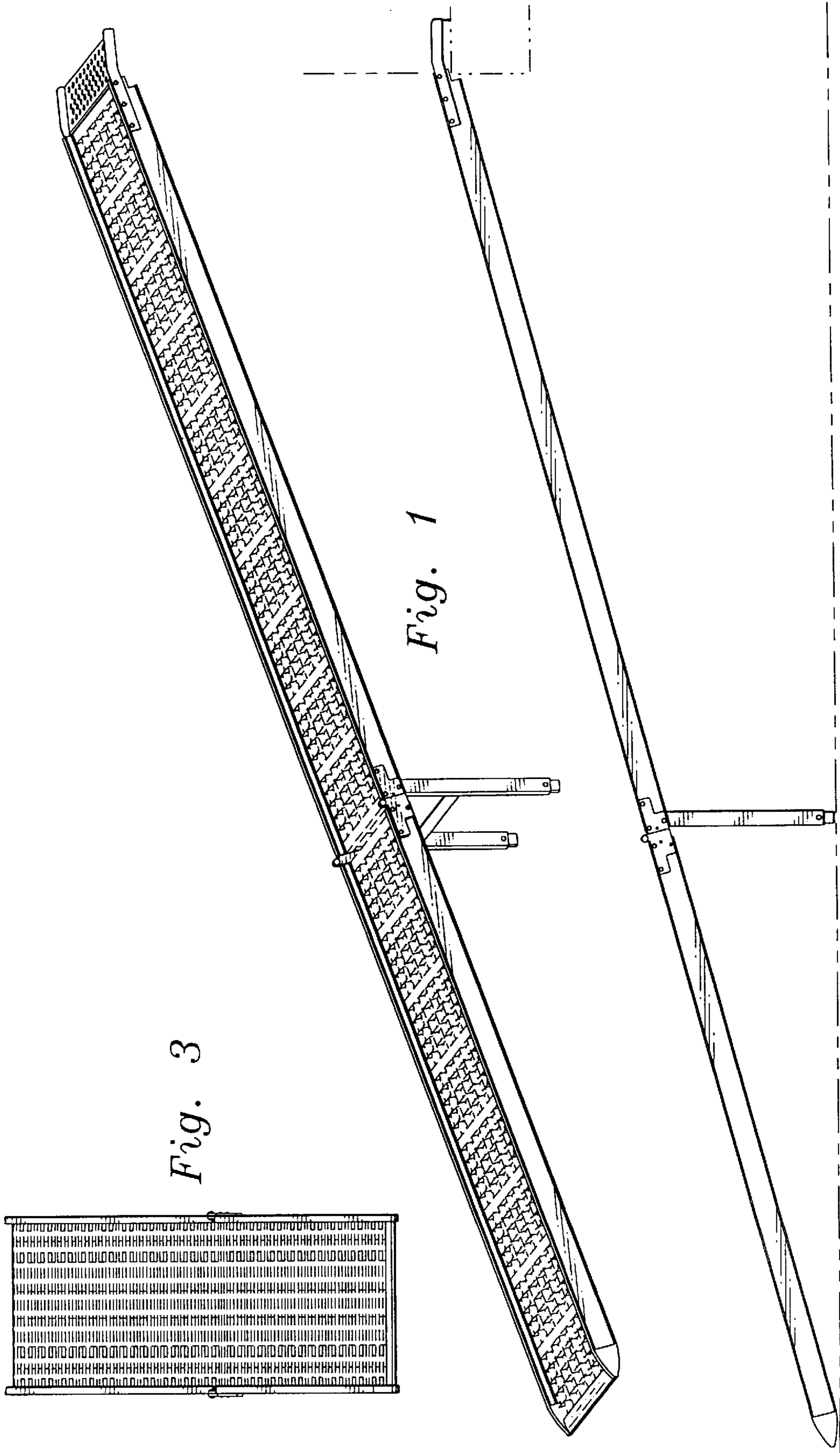

Fig. 3

Fig. 1

Fig. 2

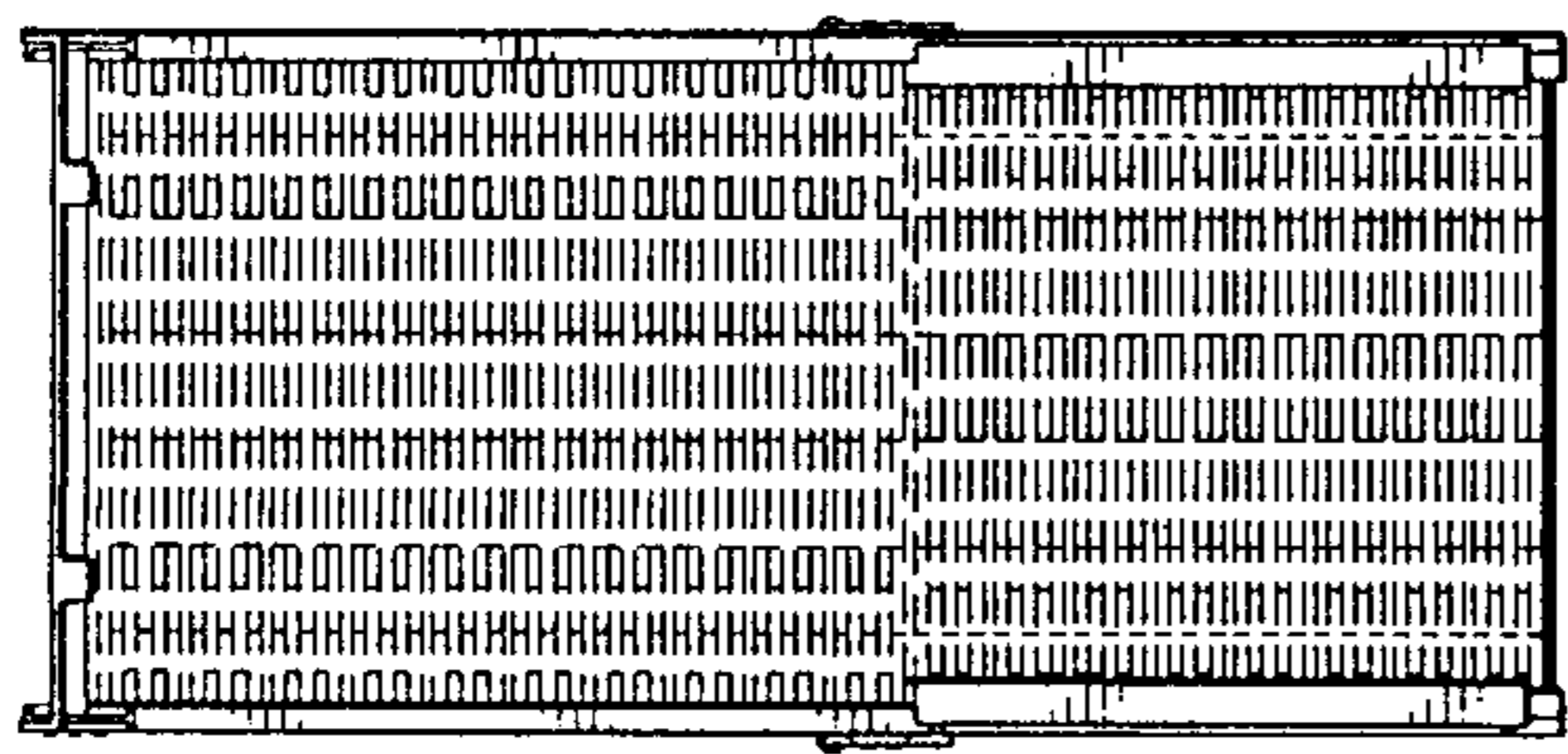

Fig. 4

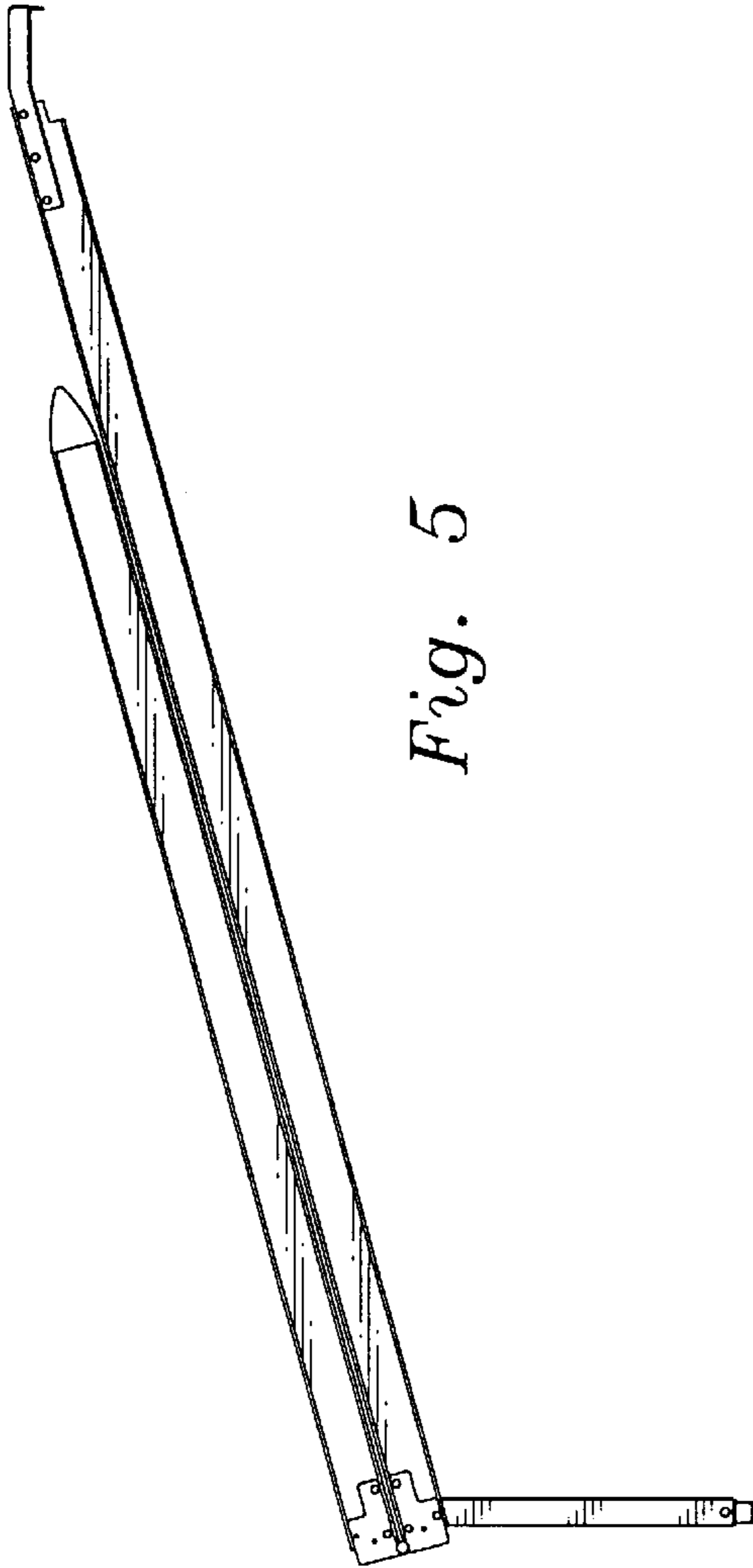

Fig. 5

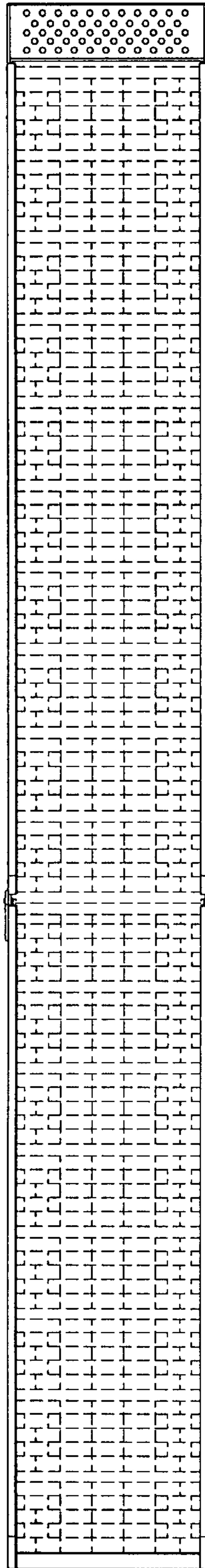

Fig. 6

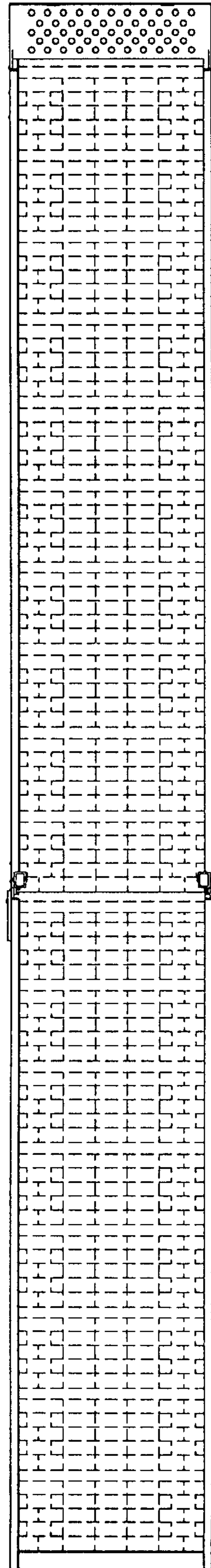

Fig. 7