



US00D401725S

United States Patent [19]
Szumal

[11] **Patent Number: Des. 401,725**

[45] **Date of Patent: **Nov. 24, 1998**

[54] **LINE TRIMMER CADDY**

Attorney, Agent, or Firm—Lothrop & West

[76] Inventor: **Edward J. Szumal**, HC 62 Box 33206,
Pinetop, Ariz. 85935

[57] **CLAIM**

[**] Term: **14 Years**

The ornamental design for a line trimmer caddy, as shown and described.

[21] Appl. No.: **76,873**

DESCRIPTION

[22] Filed: **Sep. 23, 1997**

[51] **LOC (6) Cl.** **12-02**

[52] **U.S. Cl.** **D34/24; D34/12**

[58] **Field of Search** D34/12-27; 280/652,
280/645, 655, 40, 47.19, 47.33, 47.25,
47.24, 47.17, DIG. 2; D15/14, 16, 17; 56/17.1-17.6

FIG. 1 is a rear perspective view of a line trimmer caddy, showing my new design;

FIG. 2 is a top plan view, thereof;

FIG. 3 is a front elevational view, thereof;

FIG. 4 is a side elevational view, the opposite side elevational view being substantially a mirror image, thereof;

FIG. 5 is a rear elevational view, thereof;

FIG. 6 is a bottom plan view, thereof; and,

FIG. 7 is a side elevational view taken to a reduced scale, the broken line representation of a motorized line trimmer being shown solely for illustrative purposes, forming no part of the claimed design.

[56] **References Cited**

U.S. PATENT DOCUMENTS

D. 253,638	12/1979	Killingsworth	D34/26
D. 334,451	3/1993	Lindeman	D34/15
2,658,703	11/1953	Brink et al.	280/47.24 X
5,354,089	10/1994	Sohrt et al.	280/645
5,439,241	8/1995	Nelson	280/645

OTHER PUBLICATIONS

Bright-Life Catalogue, copyright 1997 by Bright-Life Ltd., p. 10 with front and back cover.

Primary Examiner—Kay H. Chin

1 Claim, 3 Drawing Sheets

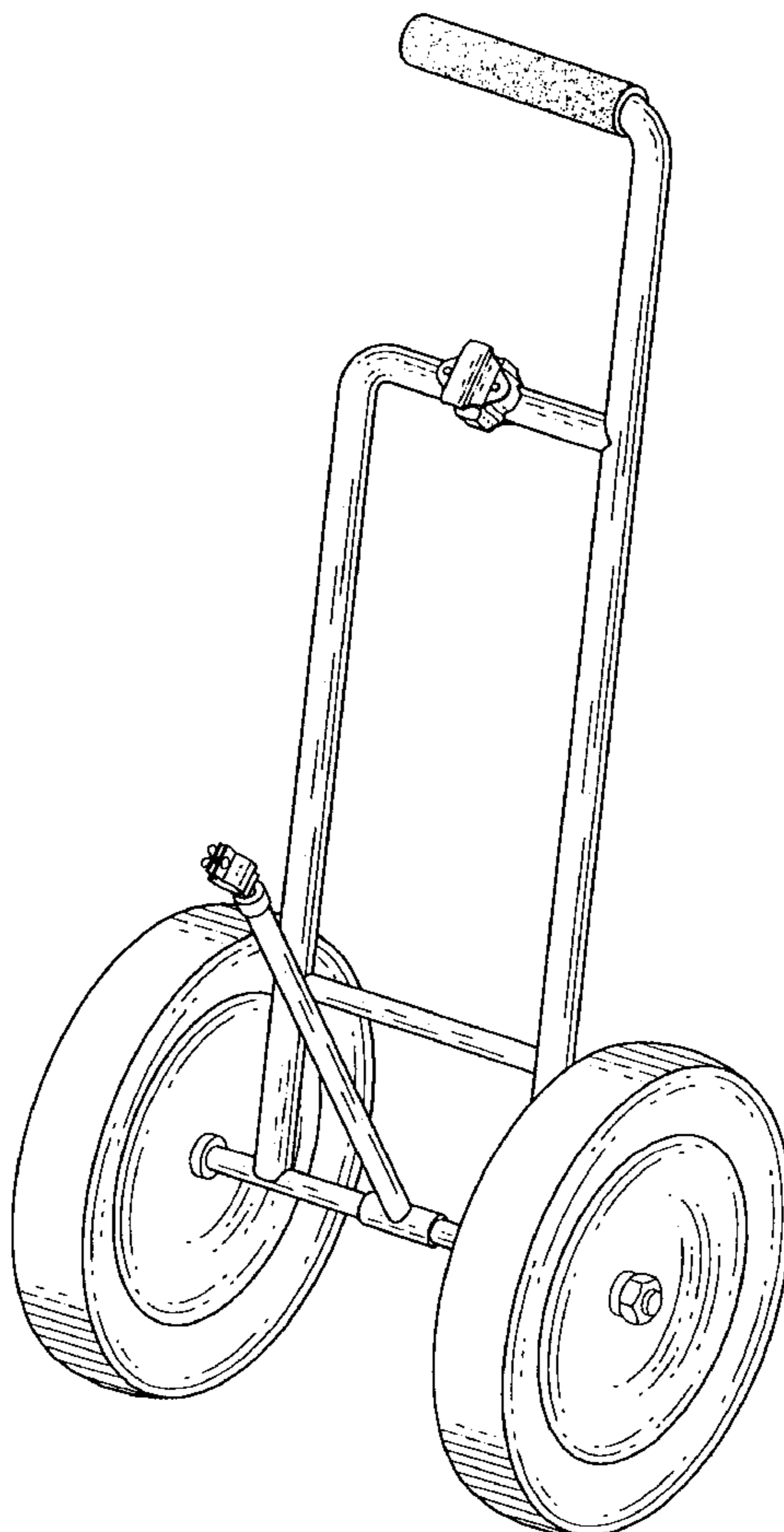

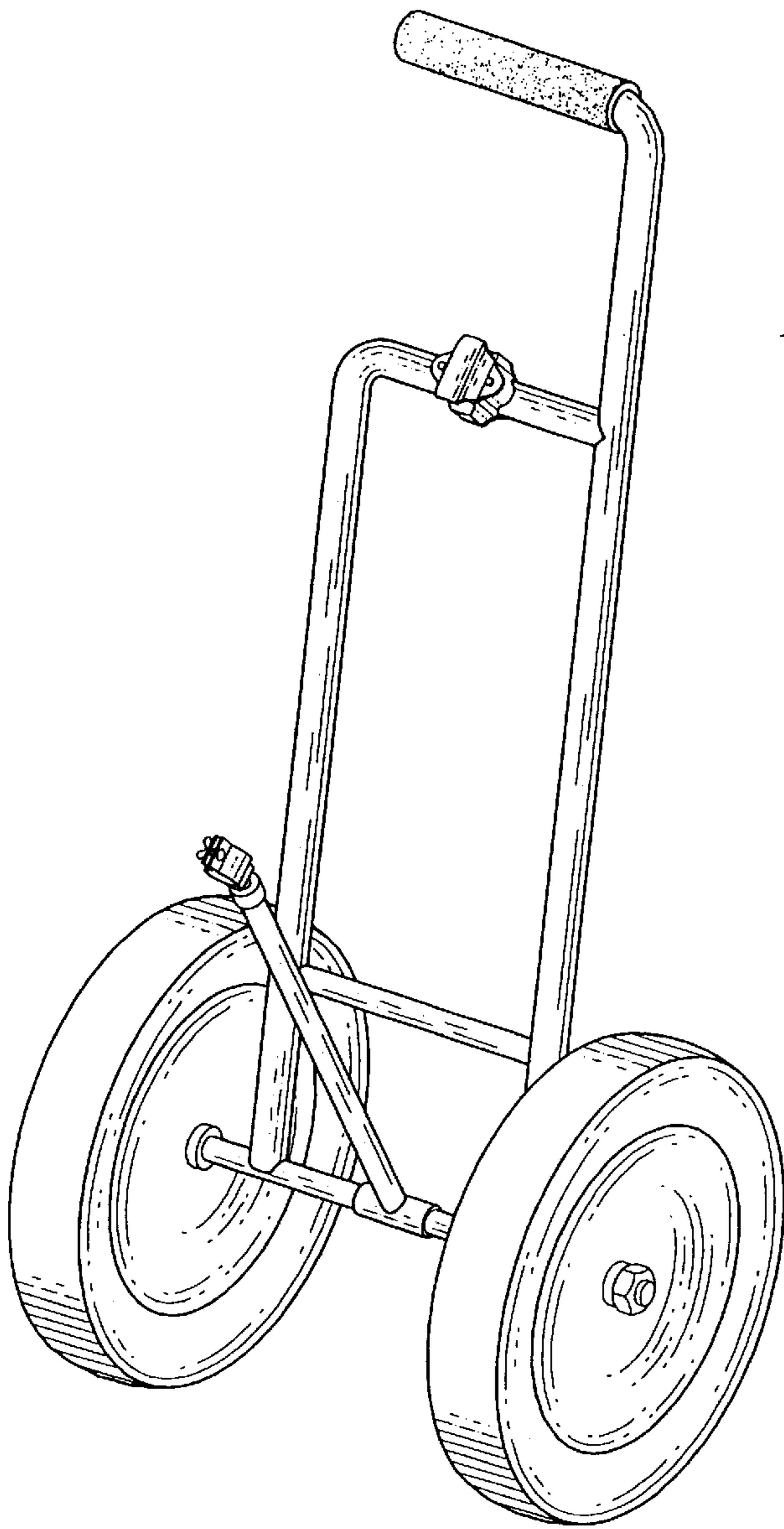

Fig. 1

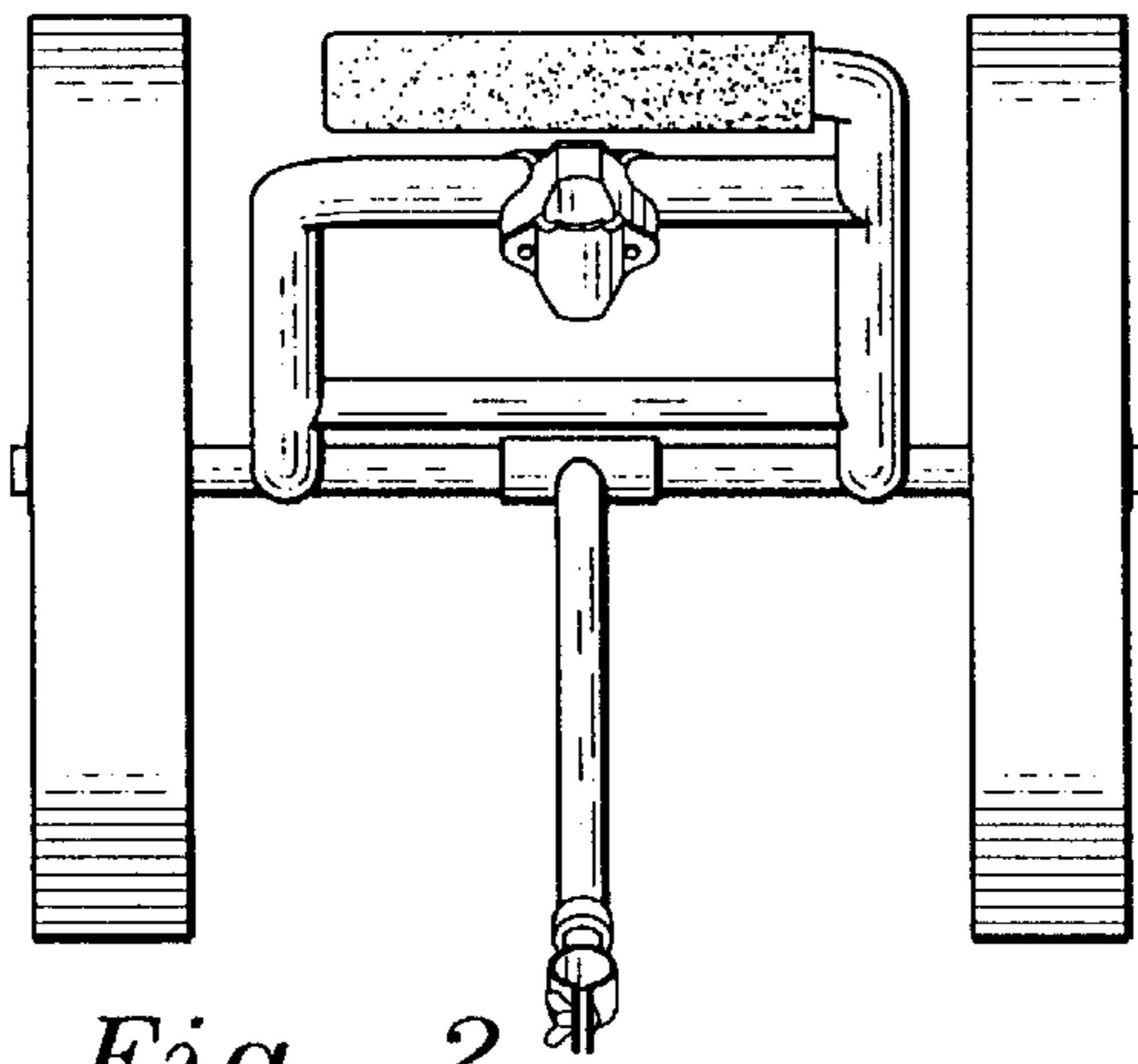

Fig. 2

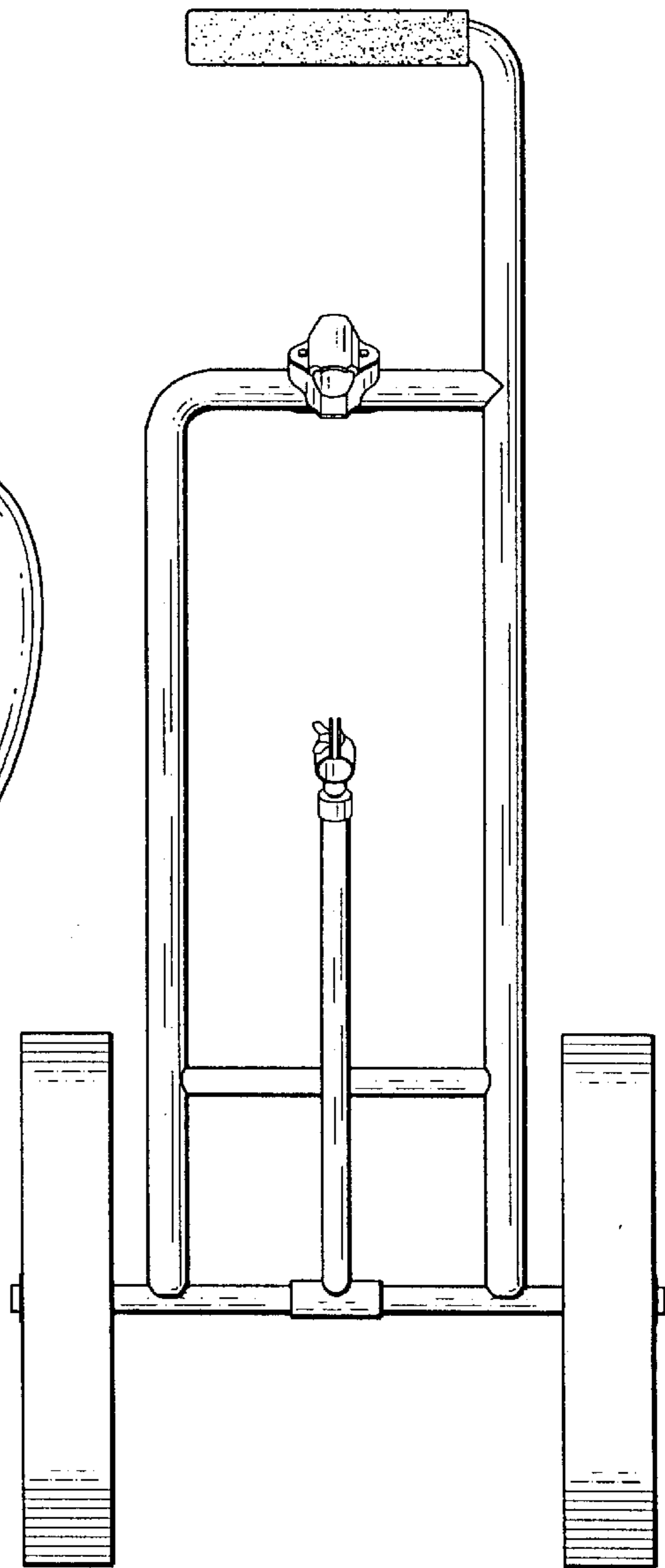
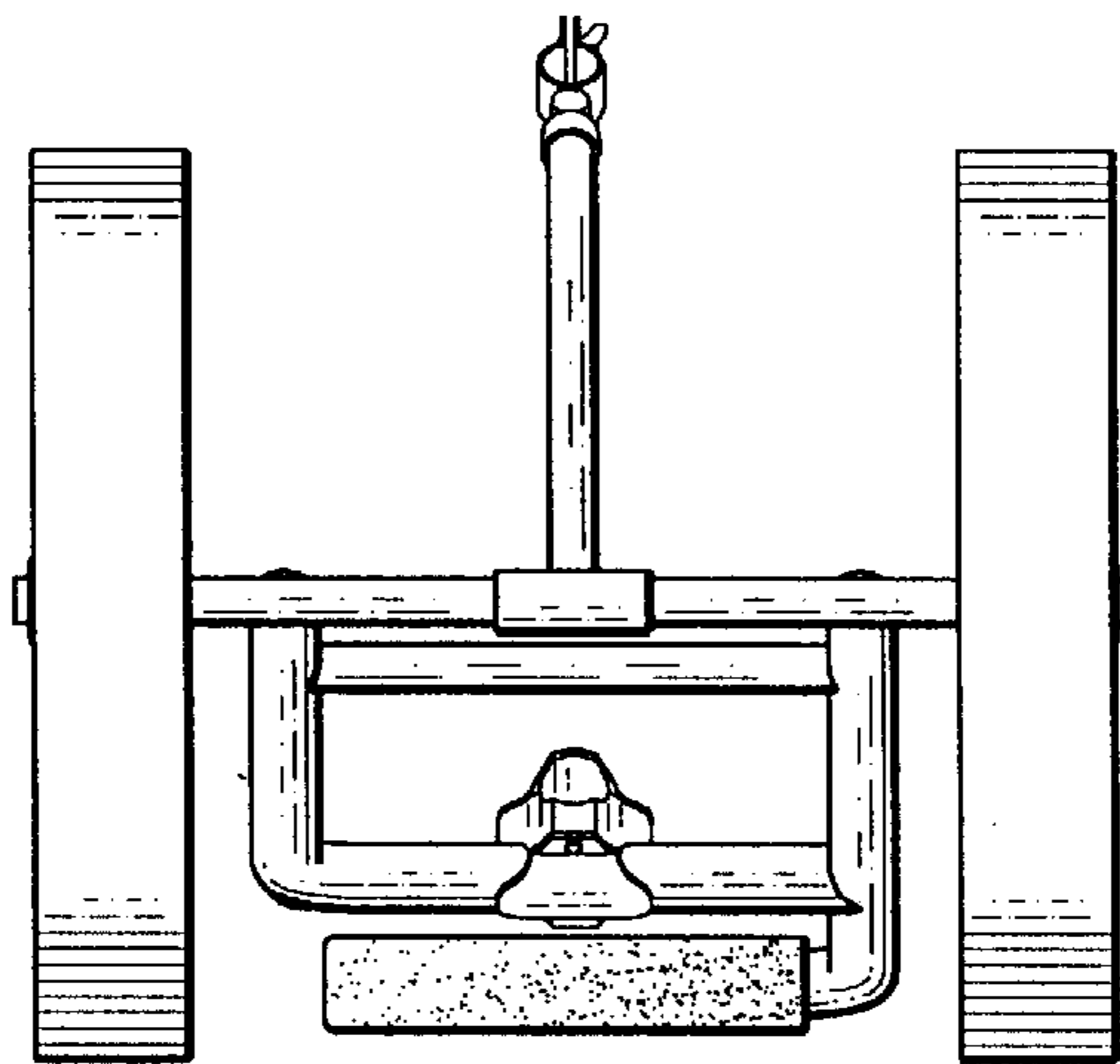
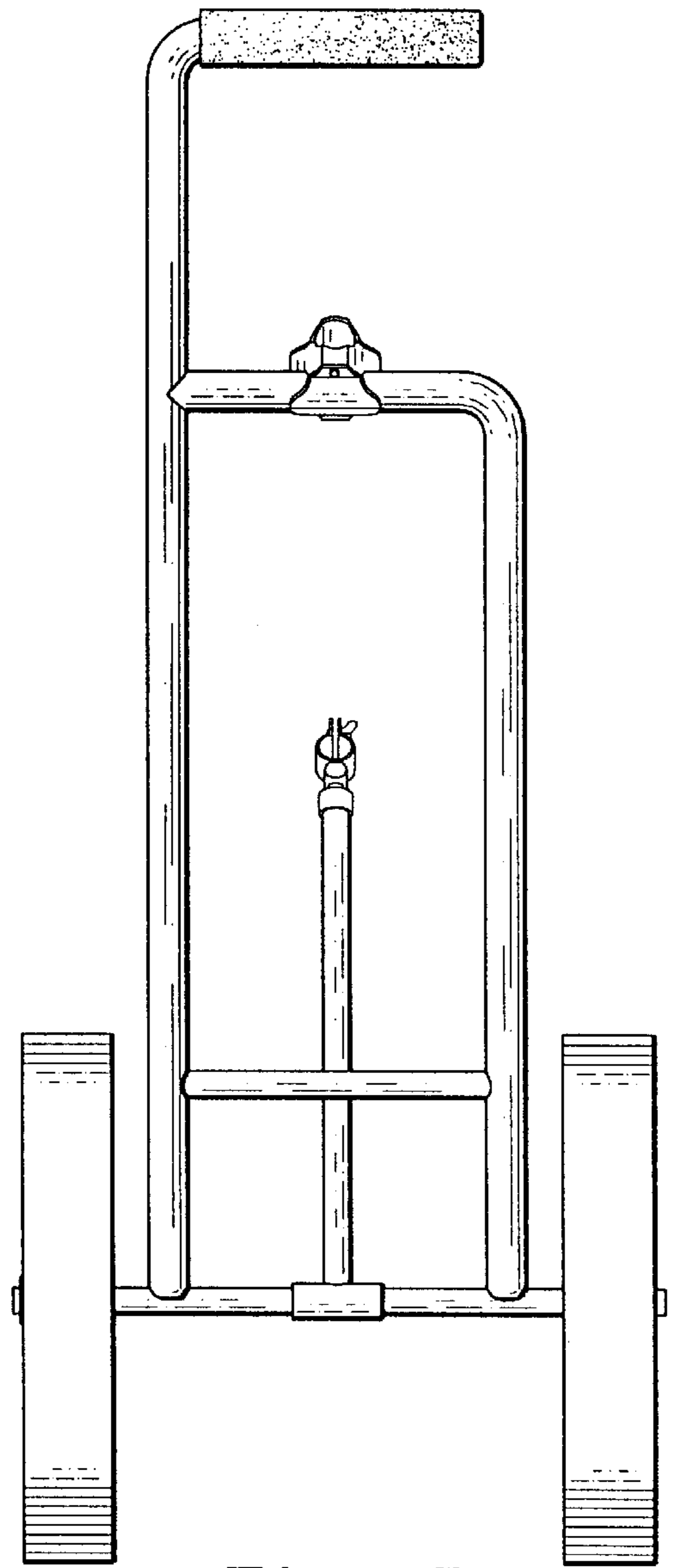
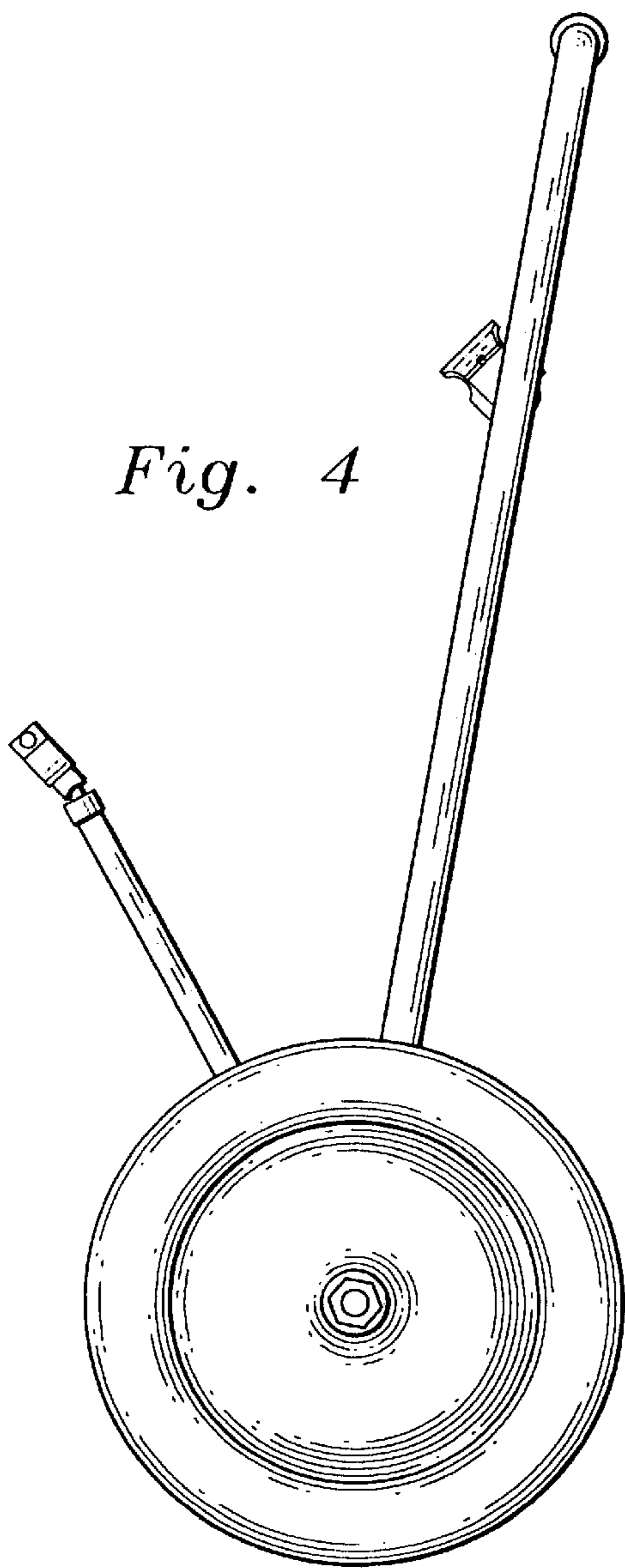

Fig. 3



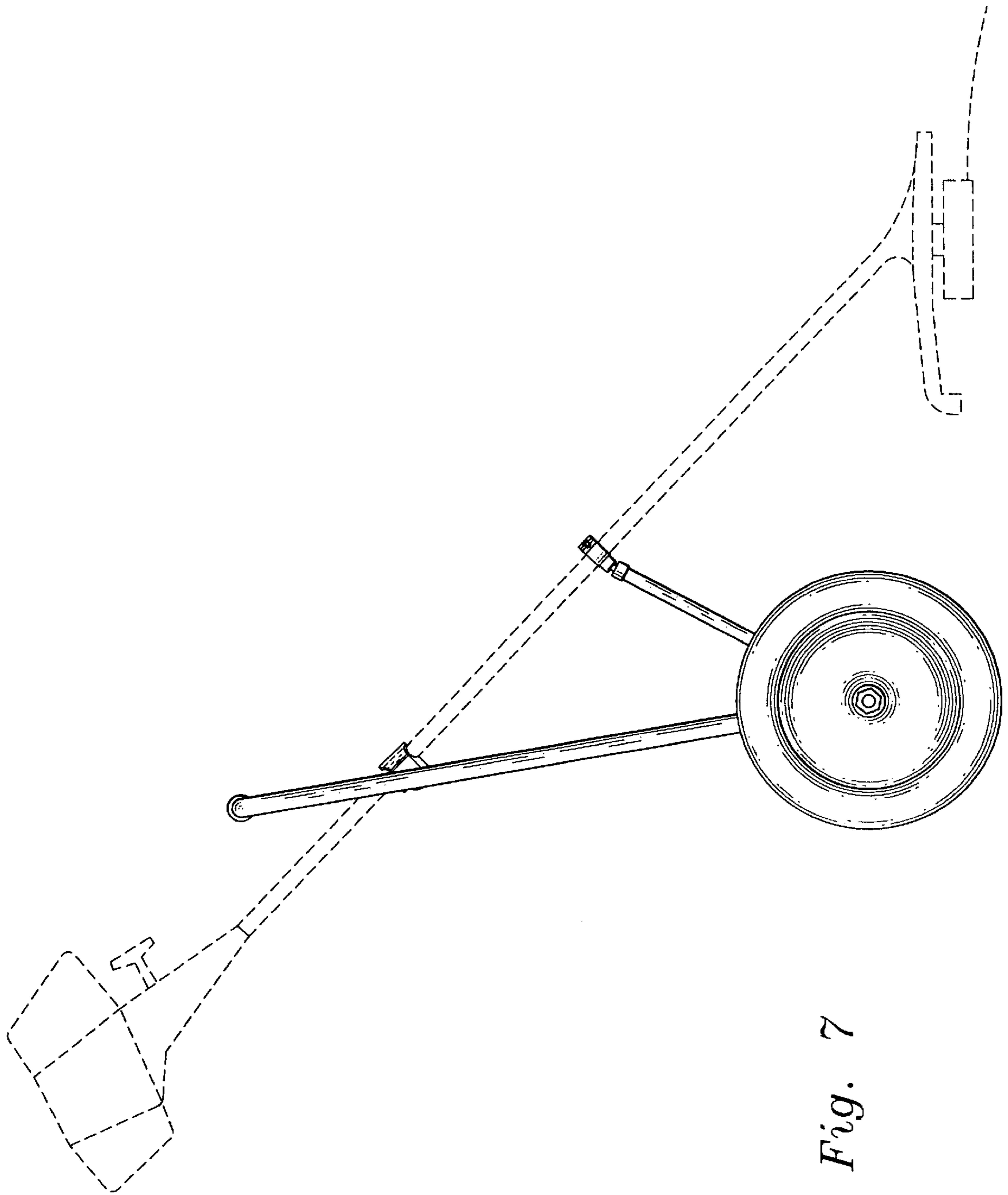

Fig. 7