



US00D401544S

**United States Patent** [19]  
**Corsetti**

[11] **Patent Number: Des. 401,544**

[45] **Date of Patent: \*\*Nov. 24, 1998**

[54] **COMBINED COVER AND STRAP FOR THE STEERING WHEEL OF A VEHICLE**

[76] Inventor: **Colin Chandler Corsetti**, 833 Southwest Bayshore Blvd., Port St. Lucie, Fla. 34983

[\*\*] Term: **14 Years**

[21] Appl. No.: **27,402**

[22] Filed: **Aug. 18, 1994**

[51] **LOC (6) Cl.** ..... **12-16**

[52] **U.S. Cl.** ..... **D12/177; D19/88**

[58] **Field of Search** ..... D12/177; D6/406, D6/419, 420, 399; D7/550, 553, 554; 74/558; 108/44; 224/276; 248/441.1, 454, 447.2; 280/727; D19/88, 90, 91

[56] **References Cited**

**U.S. PATENT DOCUMENTS**

D. 292,445	10/1987	Judge	.....	D12/177	X
D. 358,611	5/1995	Dainoff et al.	.....	D6/419	X
1,883,714	10/1932	Gray	.....	248/447.2	X
3,817,190	6/1974	Evangelista	.....	108/44	
4,995,637	2/1991	Muraishi	.....	280/727	
5,060,581	10/1991	Malinski	.....	248/441.1	X
5,386,785	2/1995	Naor	.....	108/44	

**FOREIGN PATENT DOCUMENTS**

2144627 3/1985 United Kingdom ..... 108/44

*Primary Examiner*—Freda Nunn  
*Attorney, Agent, or Firm*—Carnes Cona & Dixon

[57] **CLAIM**

I claim the ornamental design for a combined cover and strap for the steering wheel of a vehicle, as shown and described.

**DESCRIPTION**

FIG. 1 is a perspective view of a combined cover and strap for the steering wheel of a vehicle illustrating the new design;  
FIG. 2 is a perspective view;  
FIG. 3 is a side elevational view without the strap;  
FIG. 4 is a side elevational view similar to FIG. 3 showing the cover in an alternate position;  
FIG. 5 is a back elevational view;  
FIG. 6 is a front elevational view;  
FIG. 7 is a top plan view with the strap;  
FIG. 8 is a side elevational view with the strap; and,  
FIG. 9 is a bottom plan view.  
The broken lines are shown in the views for illustrative purposes only and form no part of the claimed design.

**1 Claim, 3 Drawing Sheets**

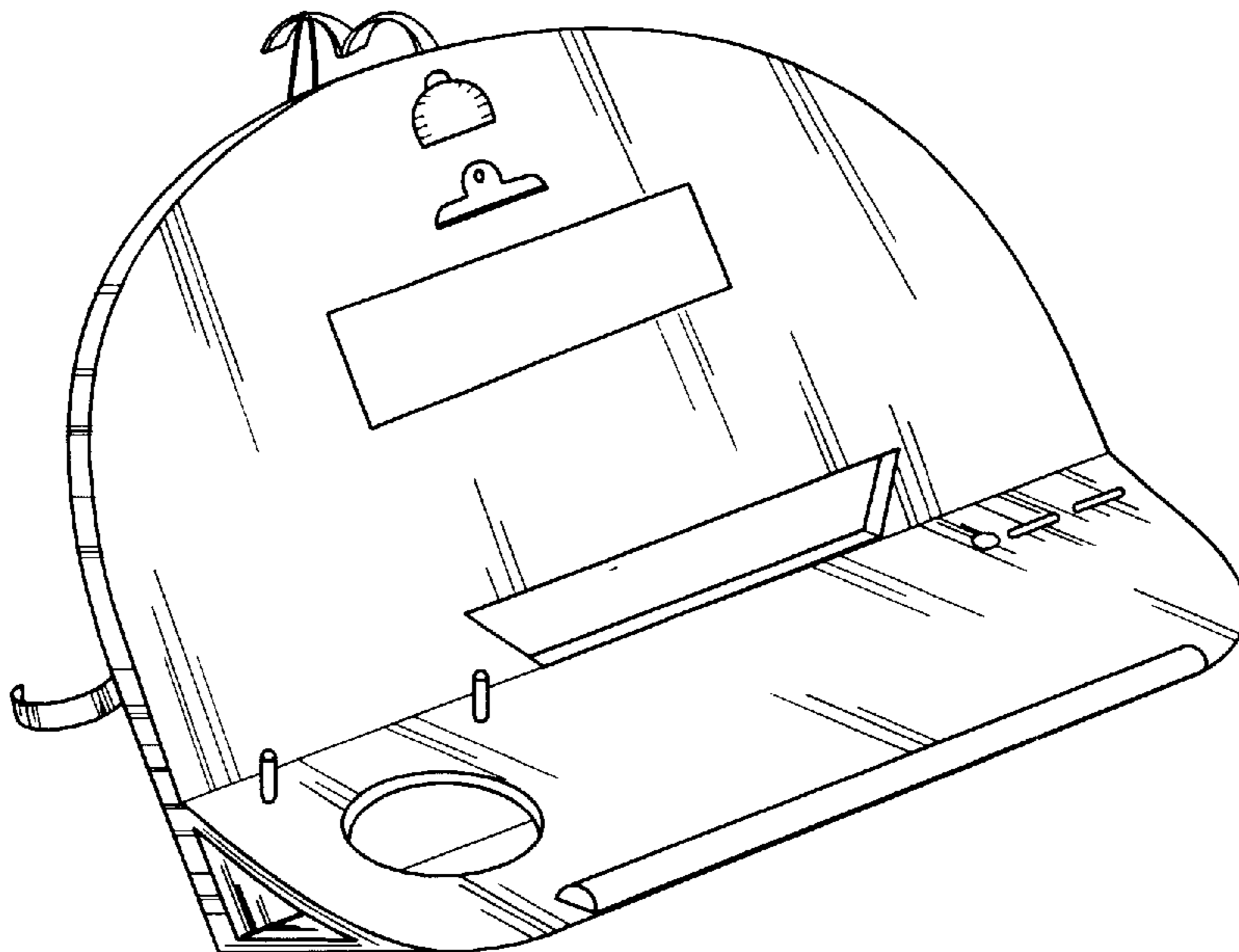

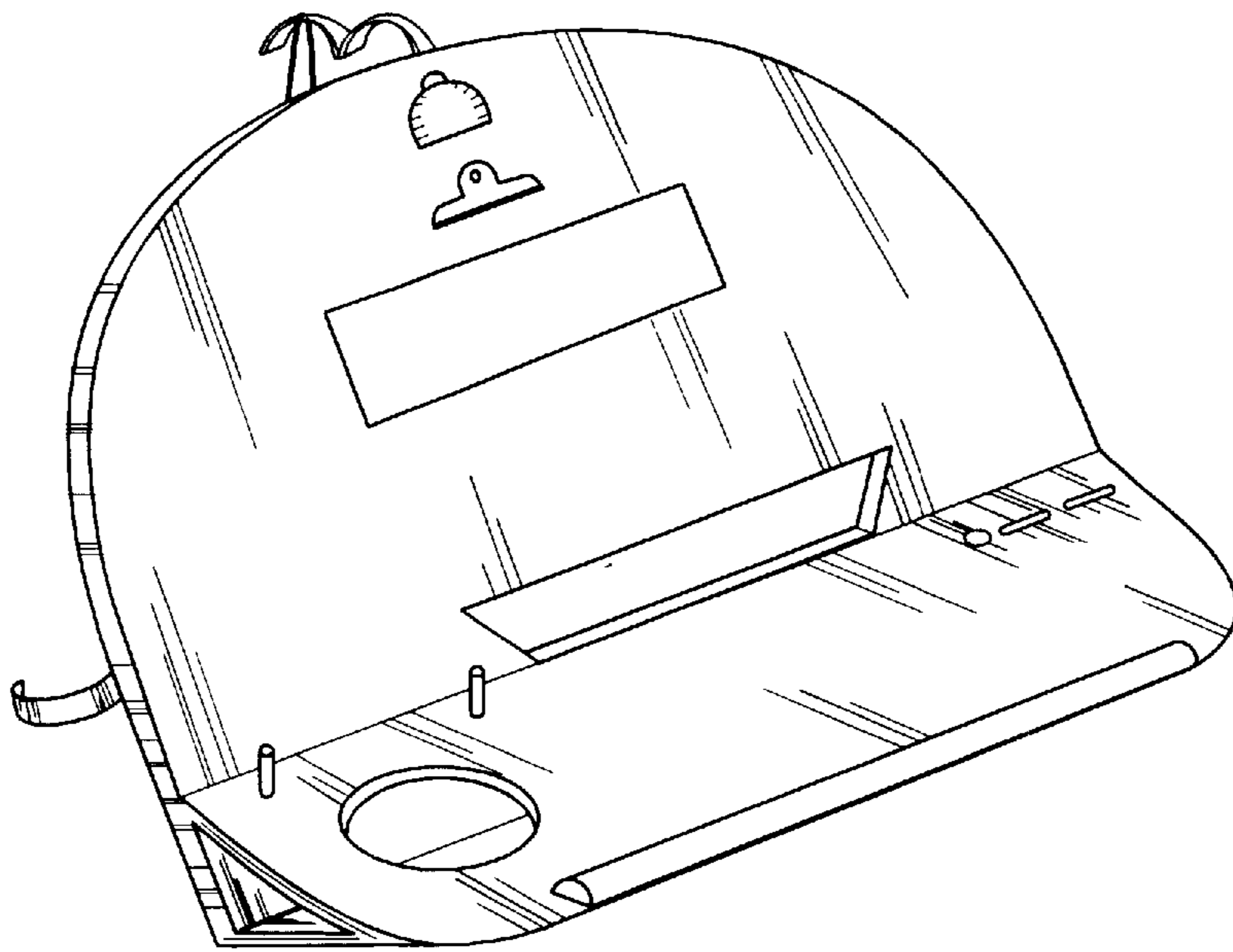

Figure 1

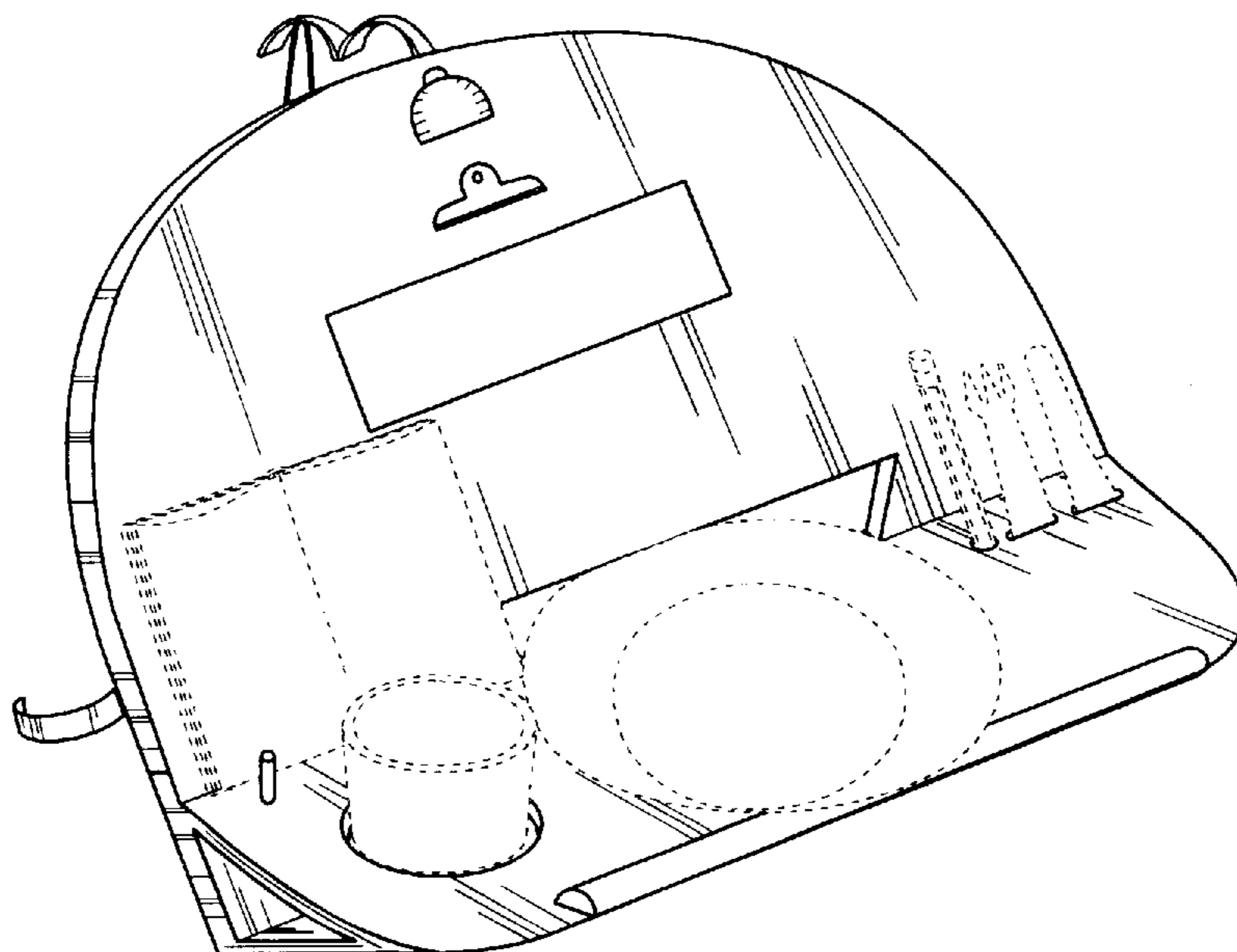

Figure 2

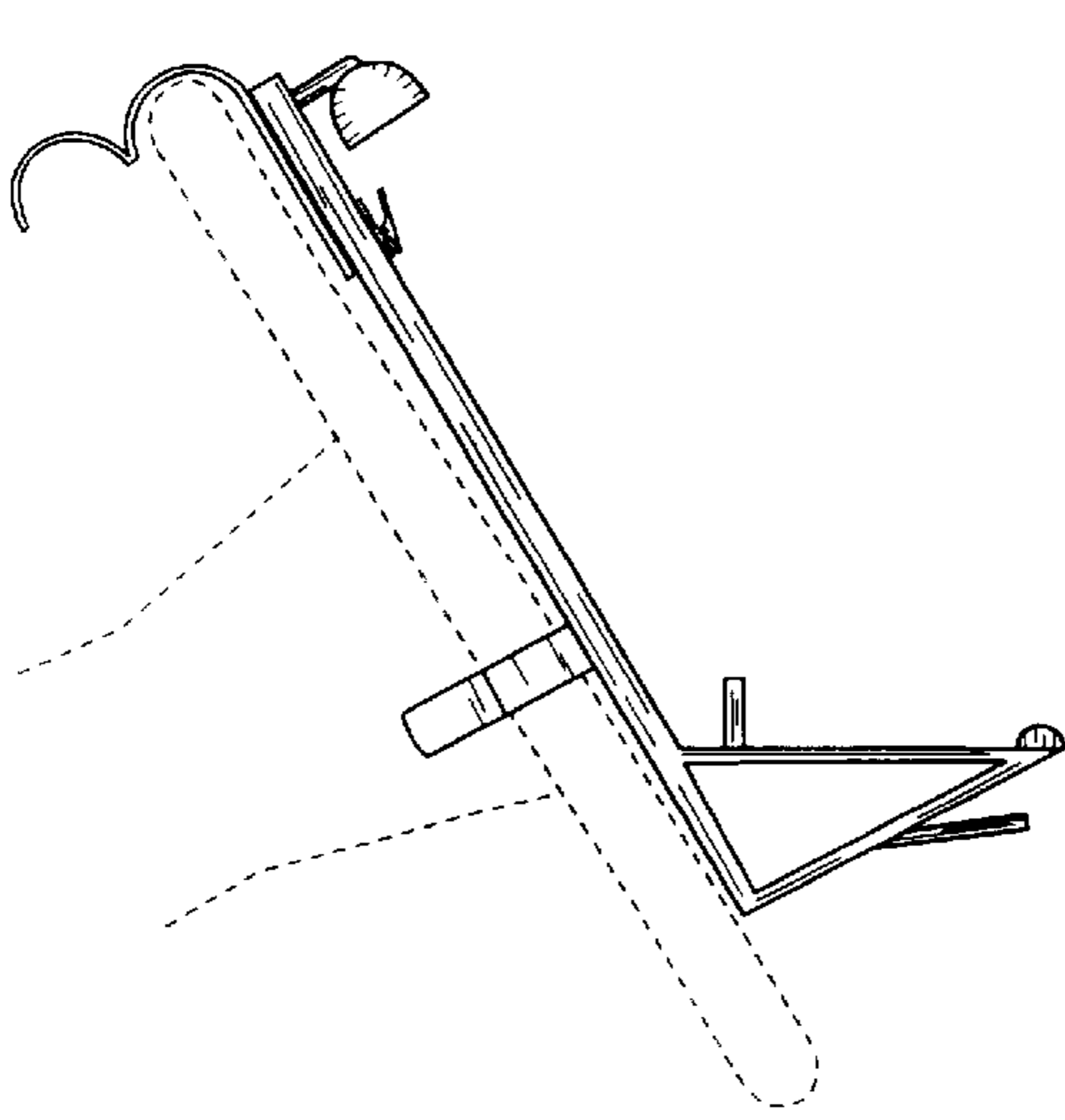

Figure 3

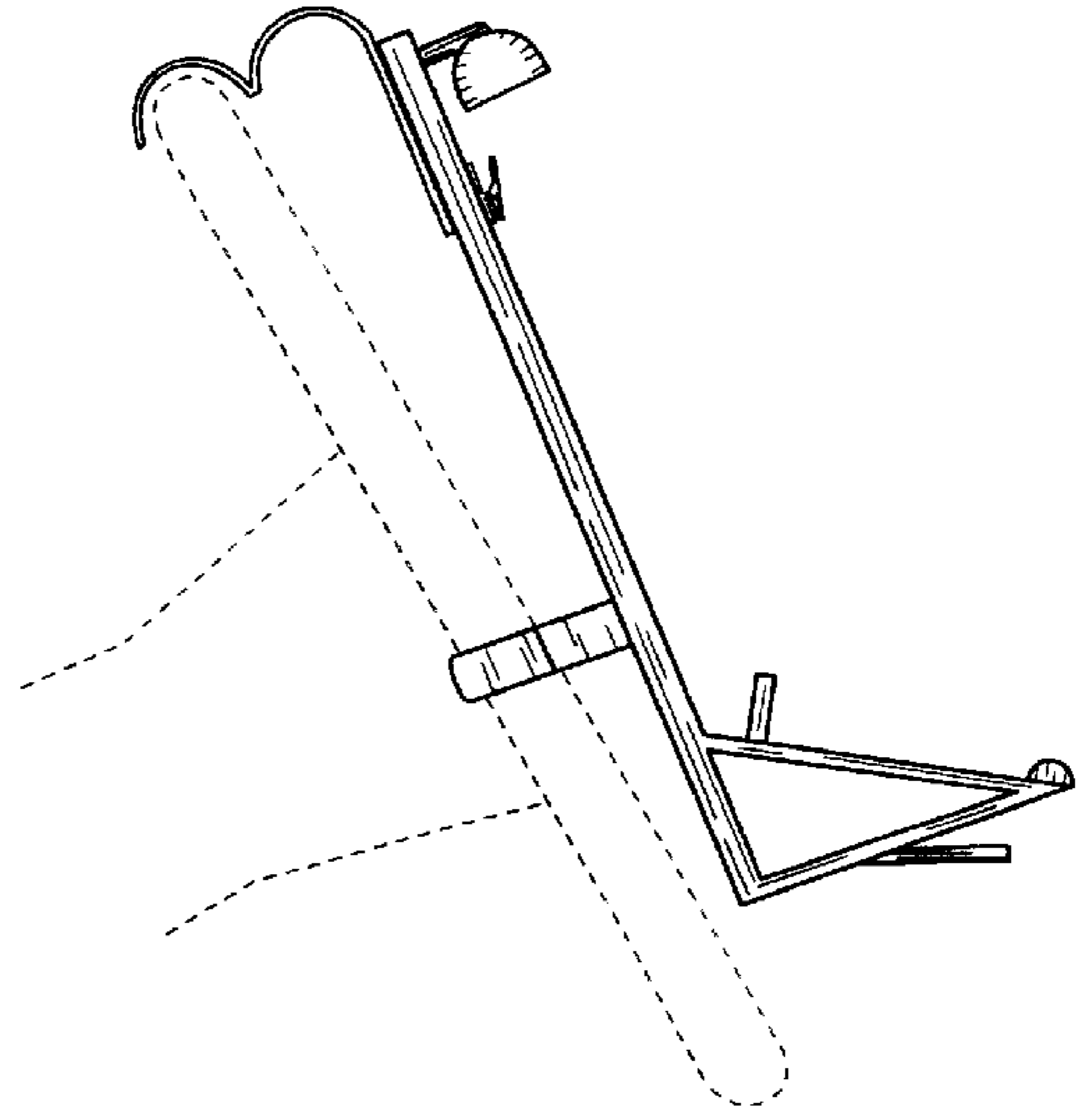

Figure 4

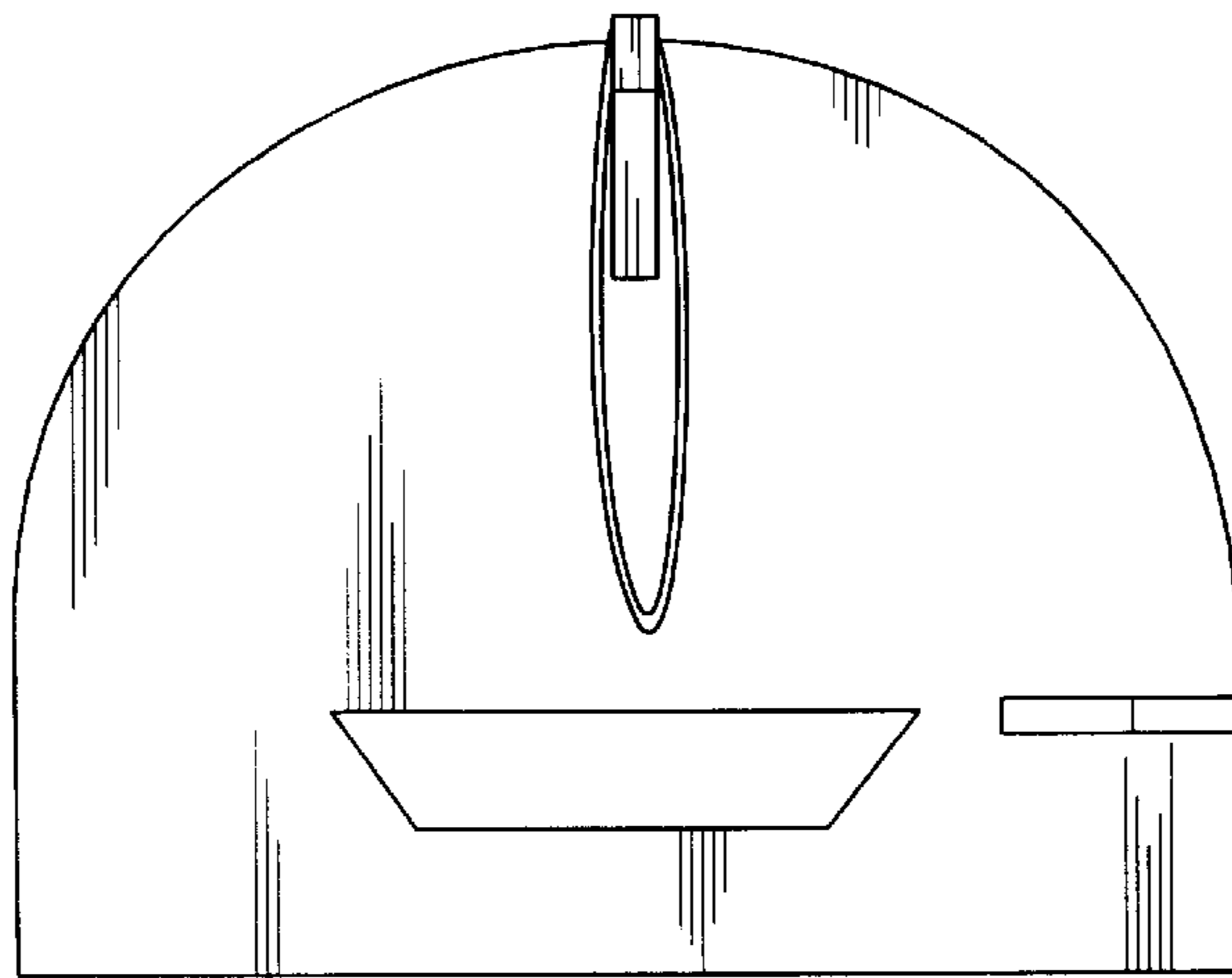

Figure 5

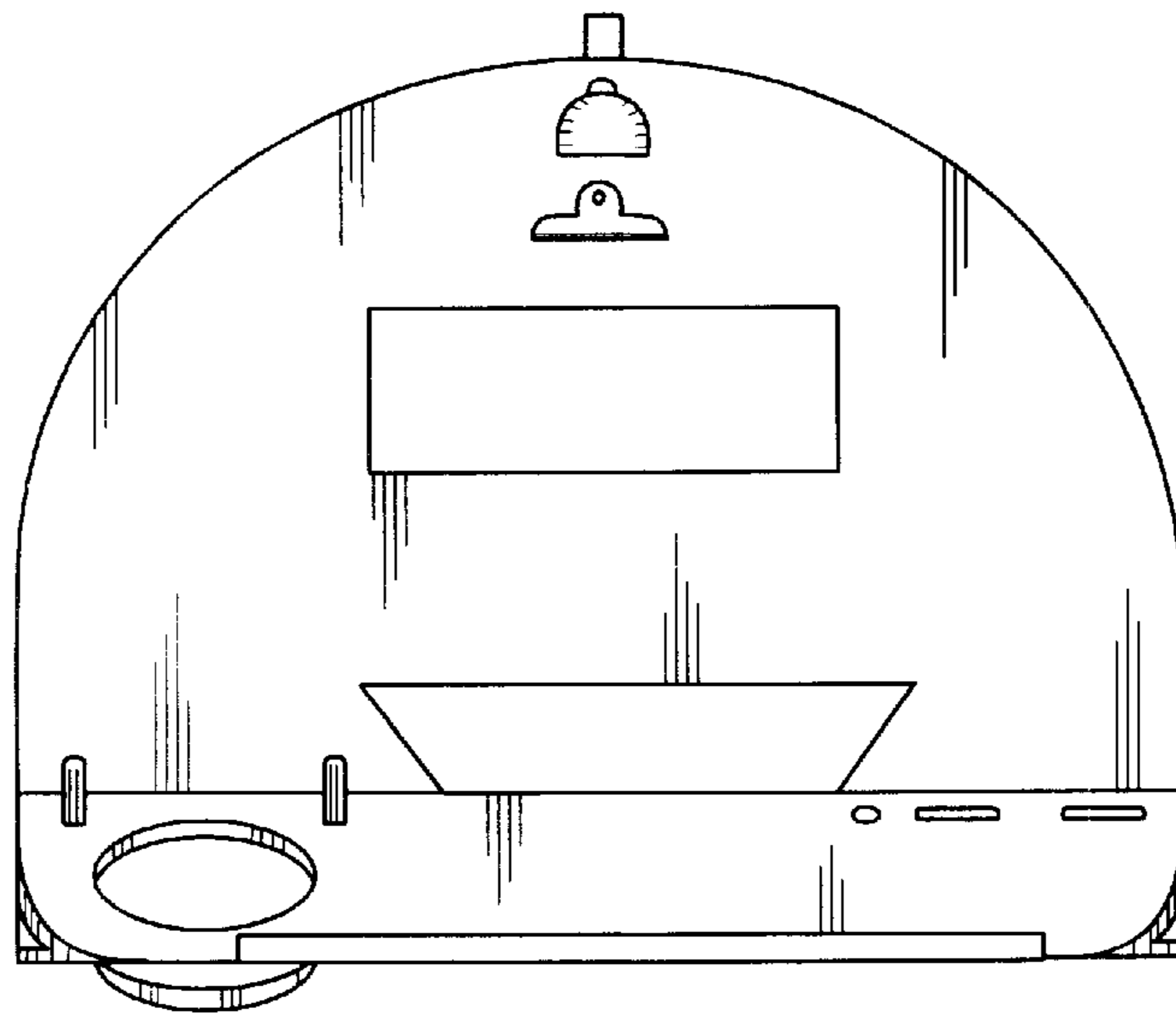

Figure 6

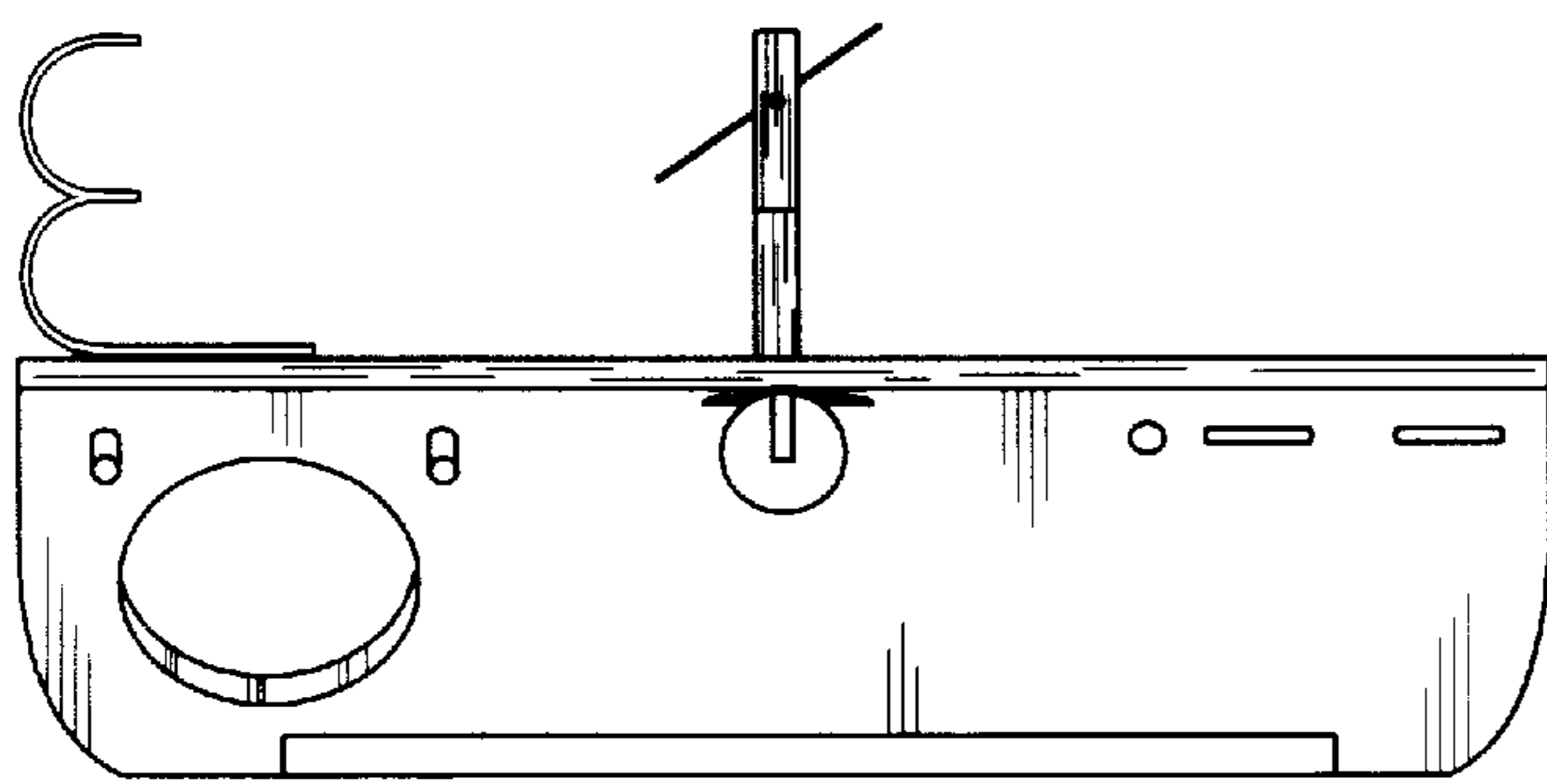

Figure 7

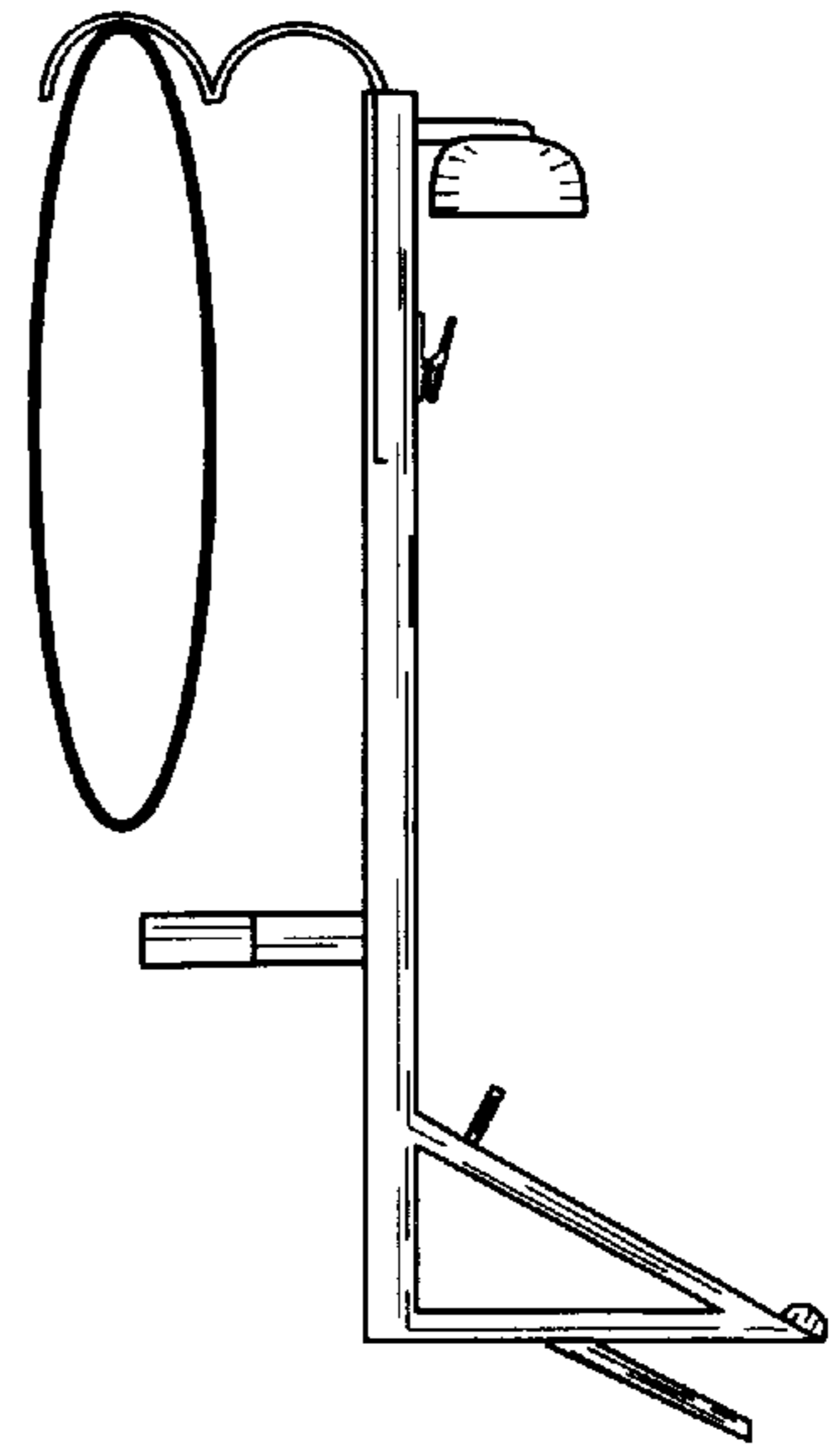

Figure 8

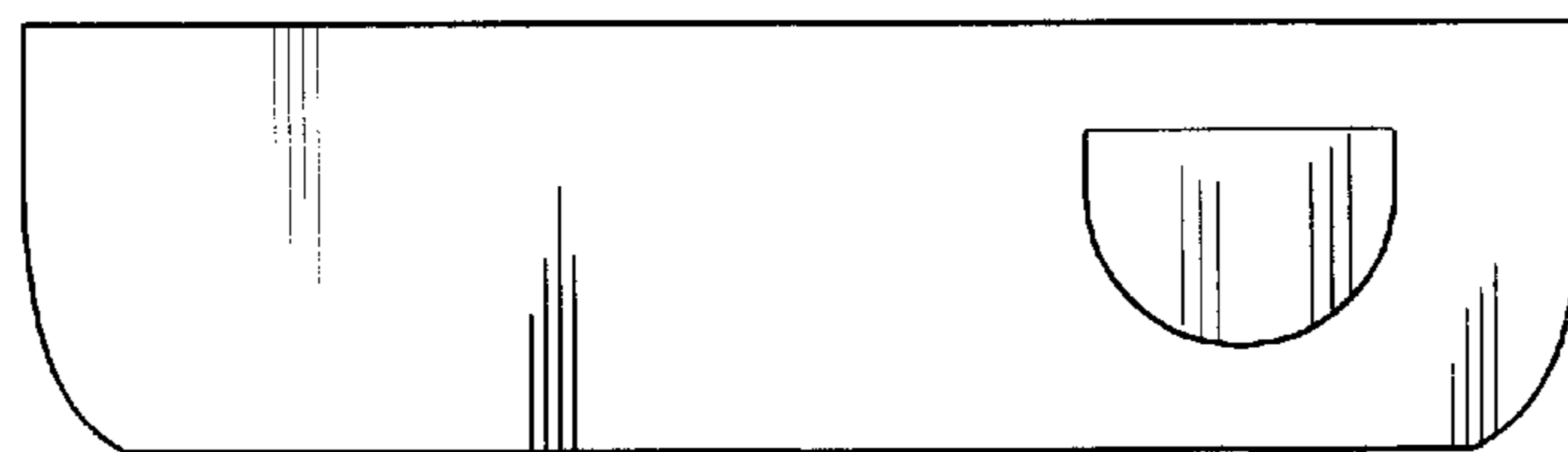

Figure 9