



US00D401535S

United States Patent [19]

Joseph, Jr.

[11] Patent Number: **Des. 401,535**

[45] Date of Patent: ****Nov. 24, 1998**

[54] **FOOT PEG FOR MOTORCYCLES AND DIRT BIKES**

[76] Inventor: **Timothy D. Joseph, Jr.**, 6320 87th St. NW., Gig Harbor, Wash. 98332

[**] Term: **14 Years**

[21] Appl. No.: **69,591**

[22] Filed: **May 5, 1997**

[51] **LOC (6) Cl.** **12-11**

[52] **U.S. Cl.** **D12/114**

[58] **Field of Search** D12/114, 125, D12/179, 120; 280/288.4, 291, 293; 180/219; 74/564, 594.4, 594.6

[56] **References Cited**

U.S. PATENT DOCUMENTS

D. 215,989	11/1969	Greenlee	D12/125
D. 216,857	3/1970	Greenlee	D12/125
D. 216,858	3/1970	Greenlee	D12/125
D. 230,016	1/1974	Corey	D12/114
D. 257,249	10/1980	Kingsbury	D12/125
D. 282,154	1/1986	Cruze et al.	D12/114
D. 292,075	9/1987	Kiyota	D12/125
D. 299,449	1/1989	Chouan	D12/125
D. 299,450	1/1989	Chouan	D12/125
D. 301,705	6/1989	Ropp	D12/125

D. 302,260	7/1989	Schieferstein	D12/125
D. 302,806	8/1989	Schieferstein	D12/125
D. 319,037	8/1991	Hoepfner, III	D12/179
D. 338,643	8/1993	Fuller et al.	D12/114
D. 378,667	4/1997	Irtoga	D12/114
3,794,353	2/1974	Oliver	280/291
4,797,791	1/1989	Burchuk	74/564
5,454,580	10/1995	Lin	280/291

Primary Examiner—Melody N. Brown
Attorney, Agent, or Firm—Richard C. Litman

[57] **CLAIM**

The ornamental design for a foot peg for motorcycles and dirt bikes, as shown and described.

DESCRIPTION

FIG. 1 is a perspective view of a foot peg for motorcycles and dirt bikes showing my new design; FIG. 2 is a front elevational view thereof; FIG. 3 is a rear elevational view thereof; FIG. 4 is a left side elevational view thereof; FIG. 5 is a right side elevational view thereof; FIG. 6 is a top view thereof; FIG. 7 is a bottom view thereof; and, FIG. 8 is an environmental perspective view thereof. The broken line showing of the motorcycle is for illustrative purposes only and forms no part of the claimed design.

1 Claim, 4 Drawing Sheets

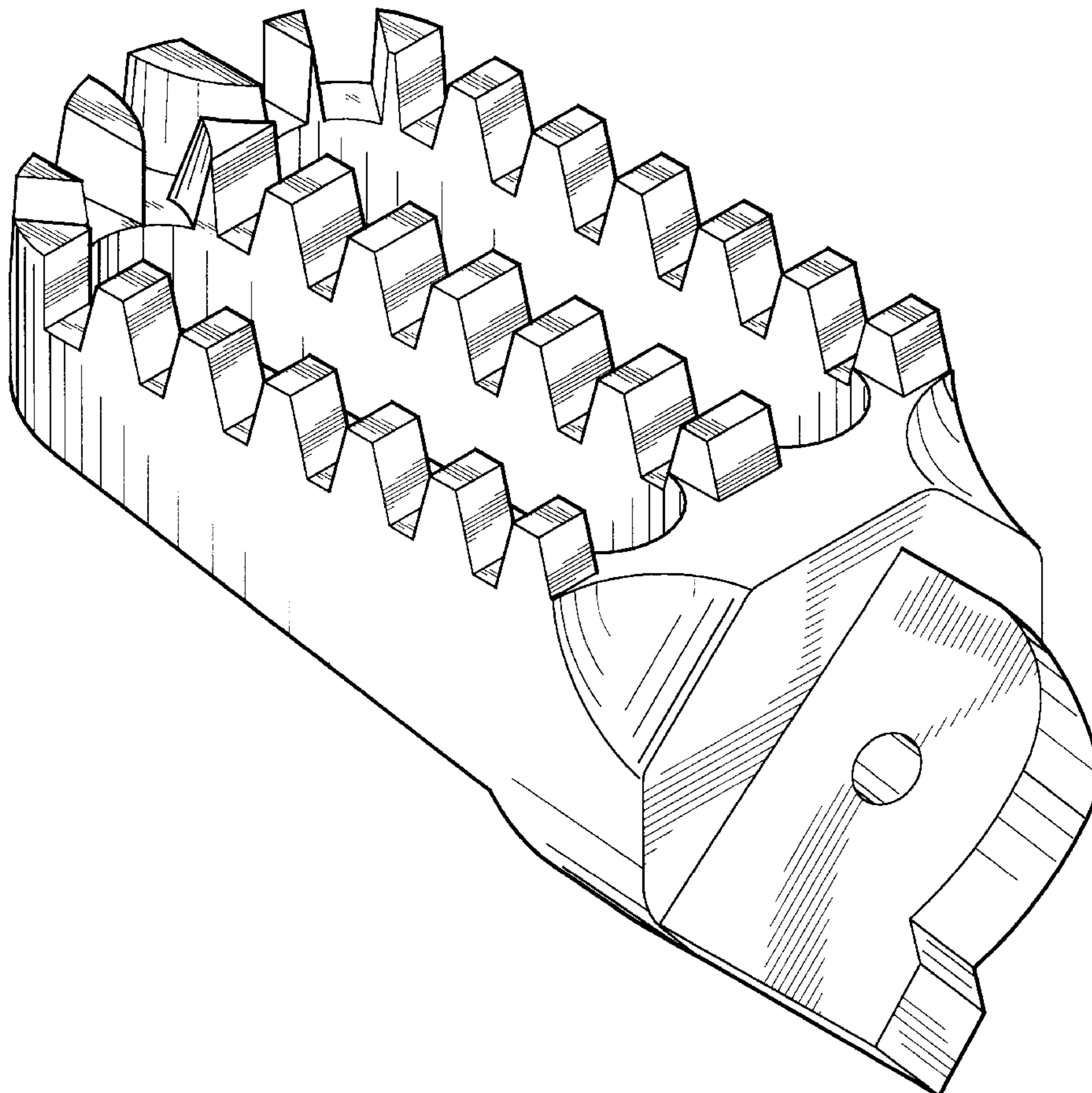

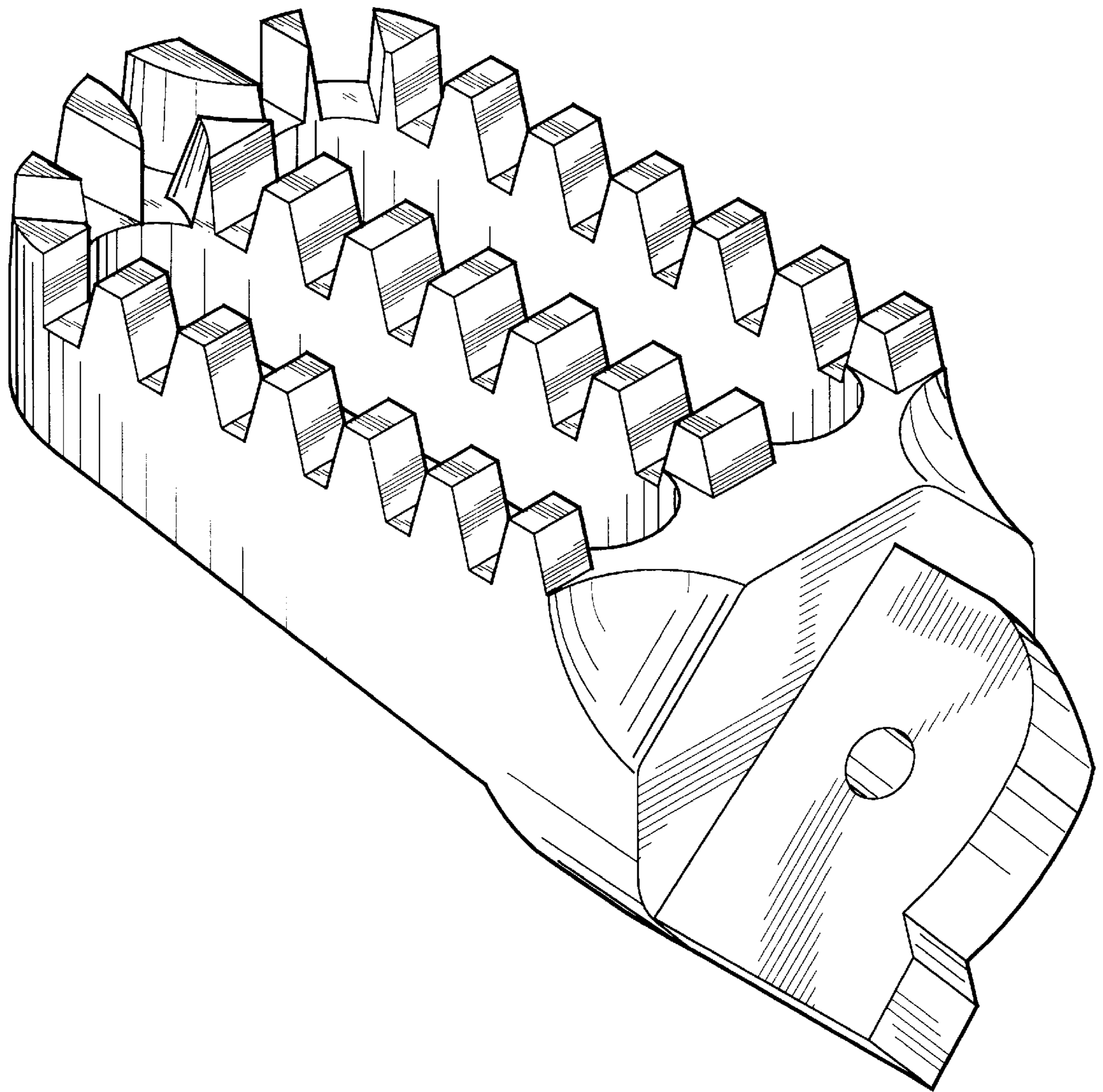

Fig. 1

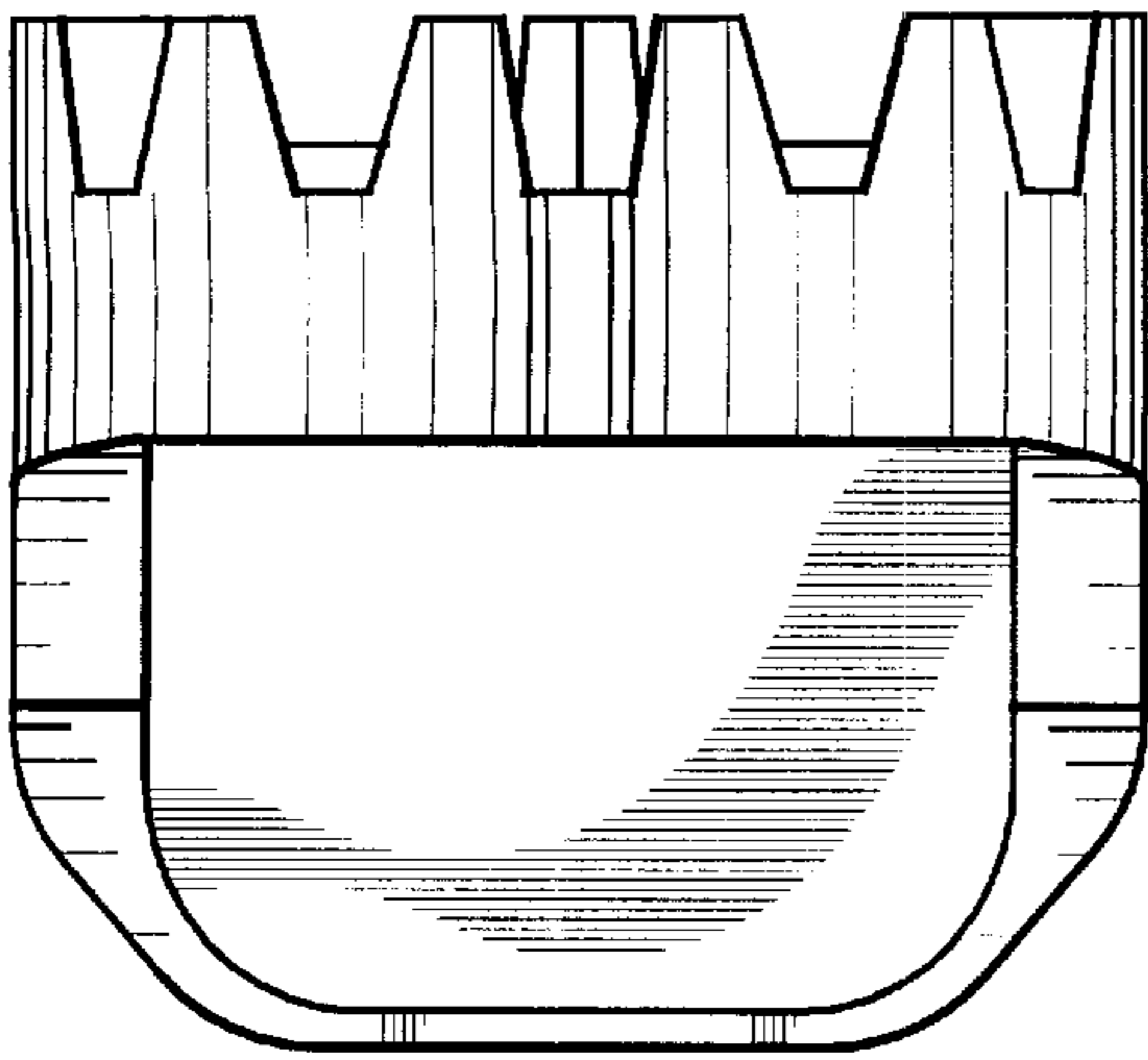

Fig. 2

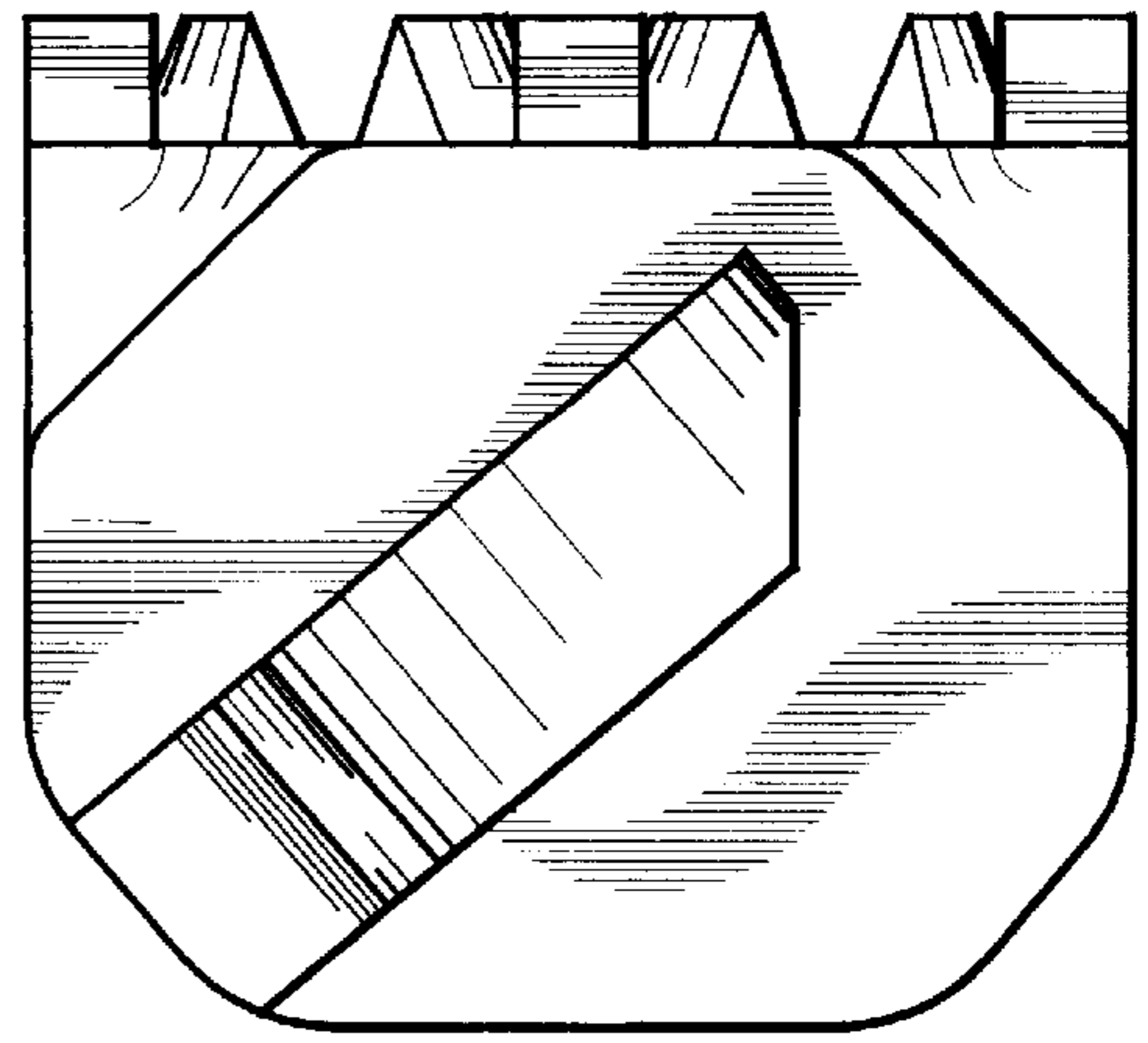

Fig. 3

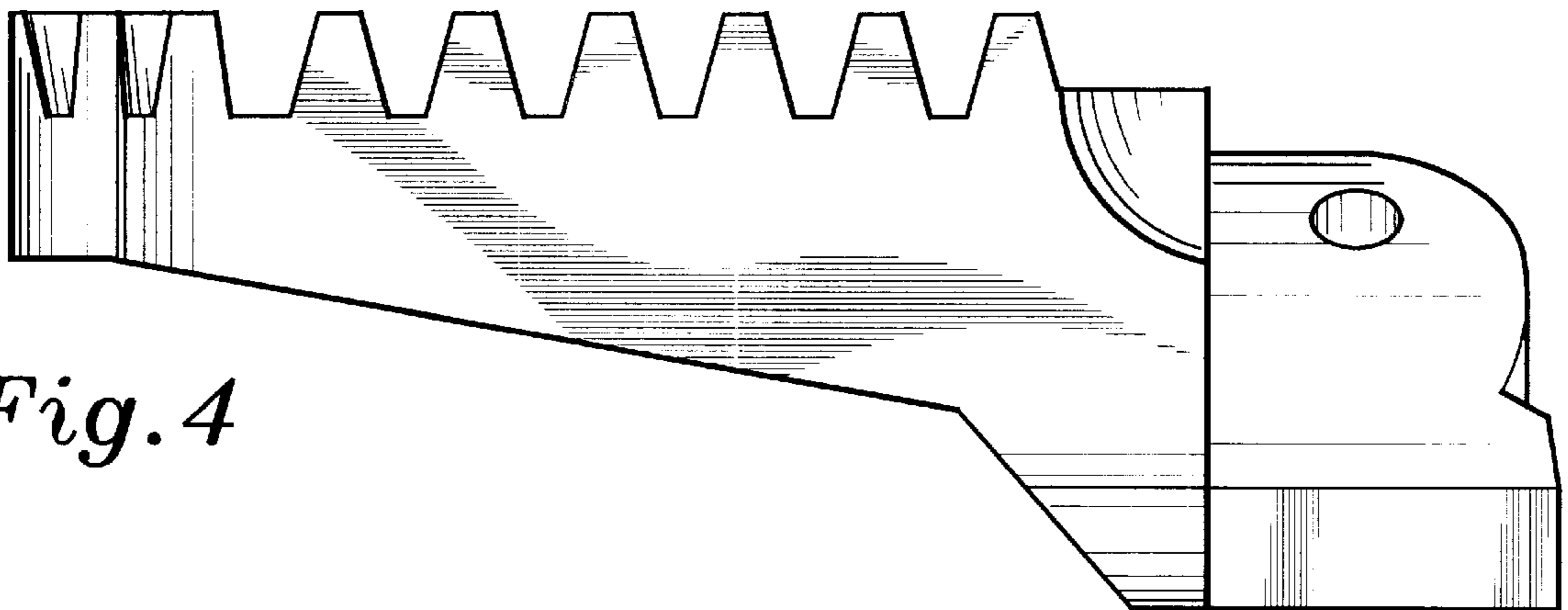

Fig. 4

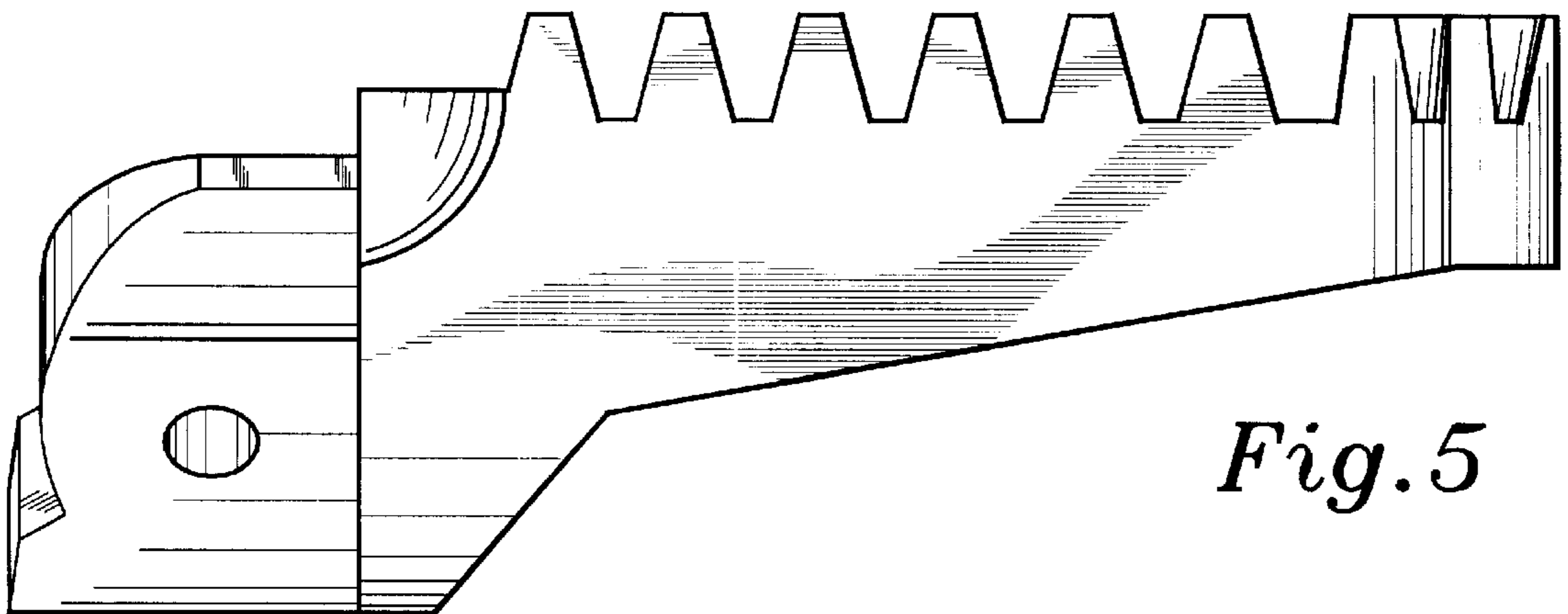

Fig. 5

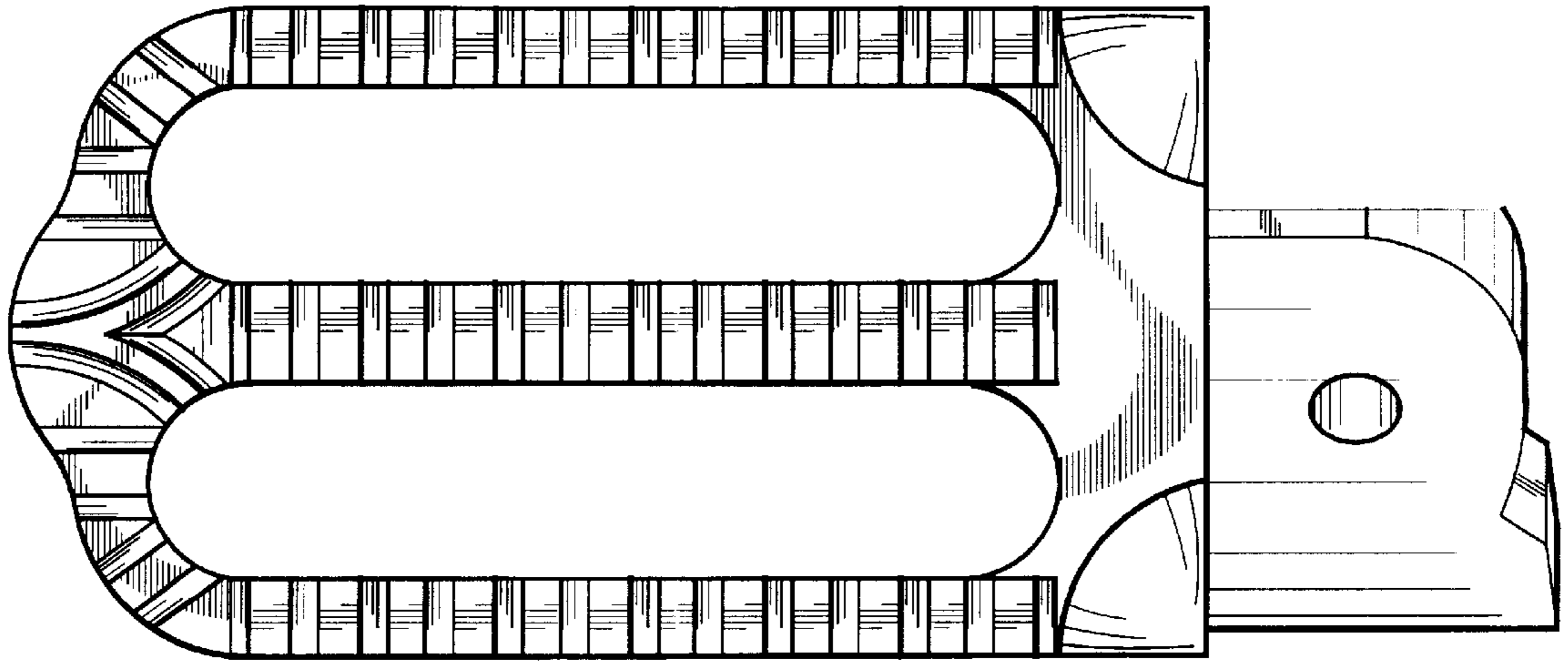

Fig. 6

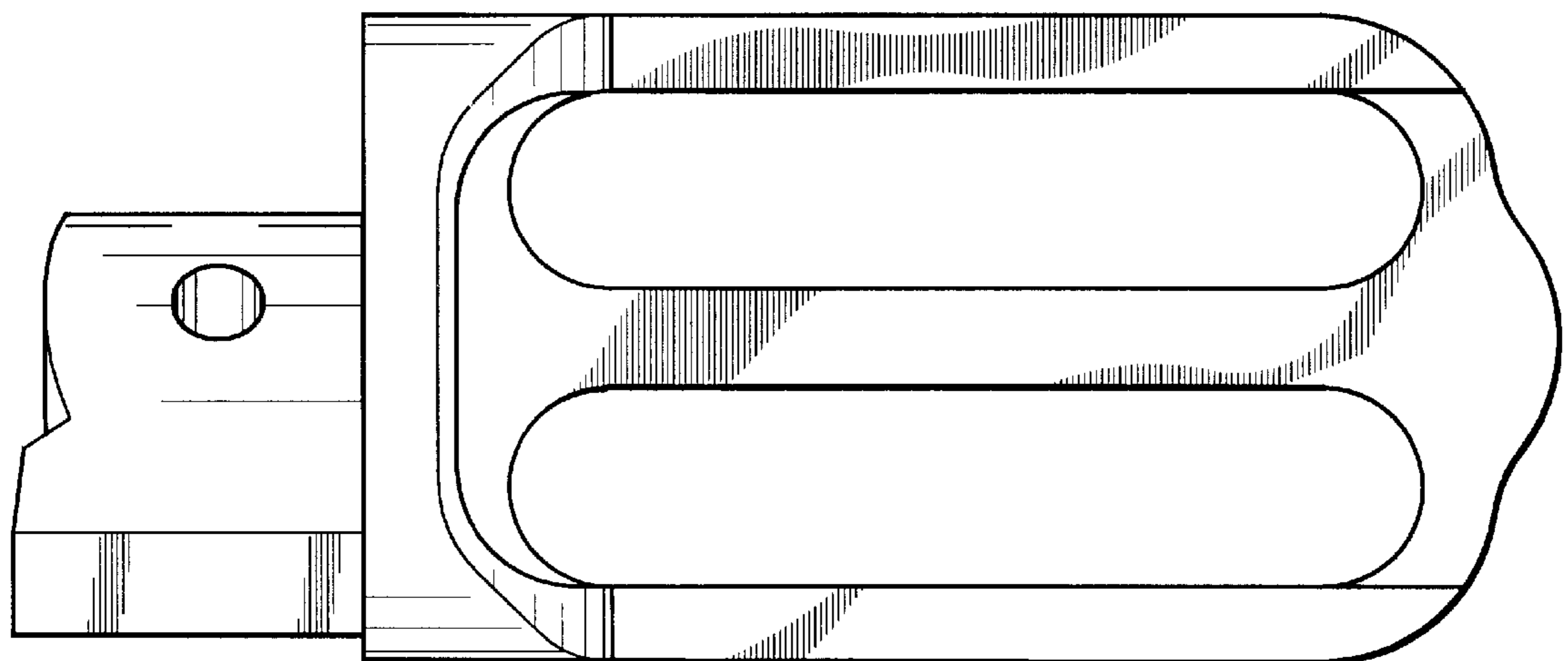

Fig. 7

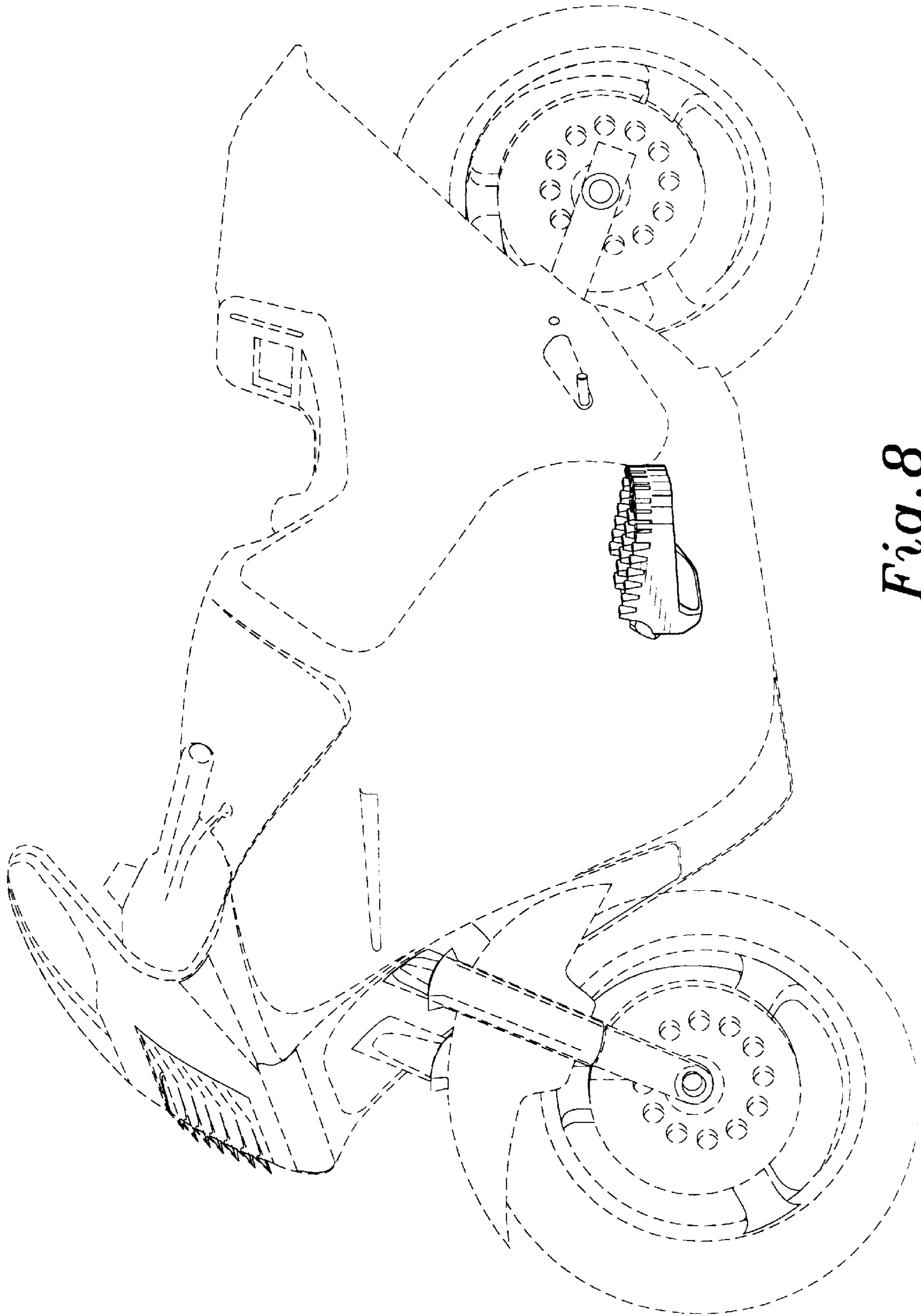

Fig. 8