



US00D401437S

United States Patent [19]

Primiano et al.

[11] **Patent Number: Des. 401,437**

[45] **Date of Patent: **Nov. 24, 1998**

[54] **MERCHANDISING DISPLAY CHANNEL FRONT**

5,351,838 10/1994 Flum 211/59.2
5,531,336 7/1996 Parham et al. 211/59.2 X
5,645,176 7/1997 Jay 211/59.2

[75] Inventors: **Bernard Primiano**, Smyrna; **Dennis E. Parham**, Kennesaw, both of Ga.

OTHER PUBLICATIONS

Advertisement brochure for the Mead product designated as "Ultra-Tracker tray" Aug. 1997.

[73] Assignee: **The Mead Corporation**, Dayton, Ohio

Primary Examiner—James Gandy
Assistant Examiner—Linda Brooks
Attorney, Agent, or Firm—Tsugihiko Suzuki

[**] Term: **14 Years**

[21] Appl. No.: **78,867**

[57] CLAIM

[22] Filed: **Nov. 4, 1997**

The ornamental design for a merchandising display channel front, as shown and described.

[51] **LOC (6) Cl.** **06-04**

[52] **U.S. Cl.** **D6/408**

DESCRIPTION

[58] **Field of Search** D6/408, 509-511, D6/466-468, 515, 475, 476, 517; 312/36, 45, 128; 221/123, 282, 286; 211/184, 189, 194, 59.2, 59.3, 59.4, 74, 49.1; 206/45.2, 386, 595, 599, 600, 736, 738-740, 745, 750-754, 756, 761

FIG. 1 is a perspective view of a merchandising display channel front showing our new design; FIG. 2 is a front elevation thereof; FIG. 3 is a right side elevation thereof; the left side elevation being a mirror image thereof; FIG. 4 is a top plan view thereof; and, FIG. 5 is a bottom plan view thereof.

[56] References Cited

U.S. PATENT DOCUMENTS

D. 290,790 7/1987 Nathan et al. D6/408
D. 295,813 5/1988 Rowes et al. D6/408
2,218,444 10/1940 Vineyard 211/49
3,104,137 9/1963 Cohen 312/71
4,801,025 1/1989 Flum et al. 211/59.2 X

The broken lines showing the channel body are for illustrative purposes only and form no part of the claimed design. The broken line which define the boundaries of the merchandising display channel front form no part thereof.

1 Claim, 2 Drawing Sheets

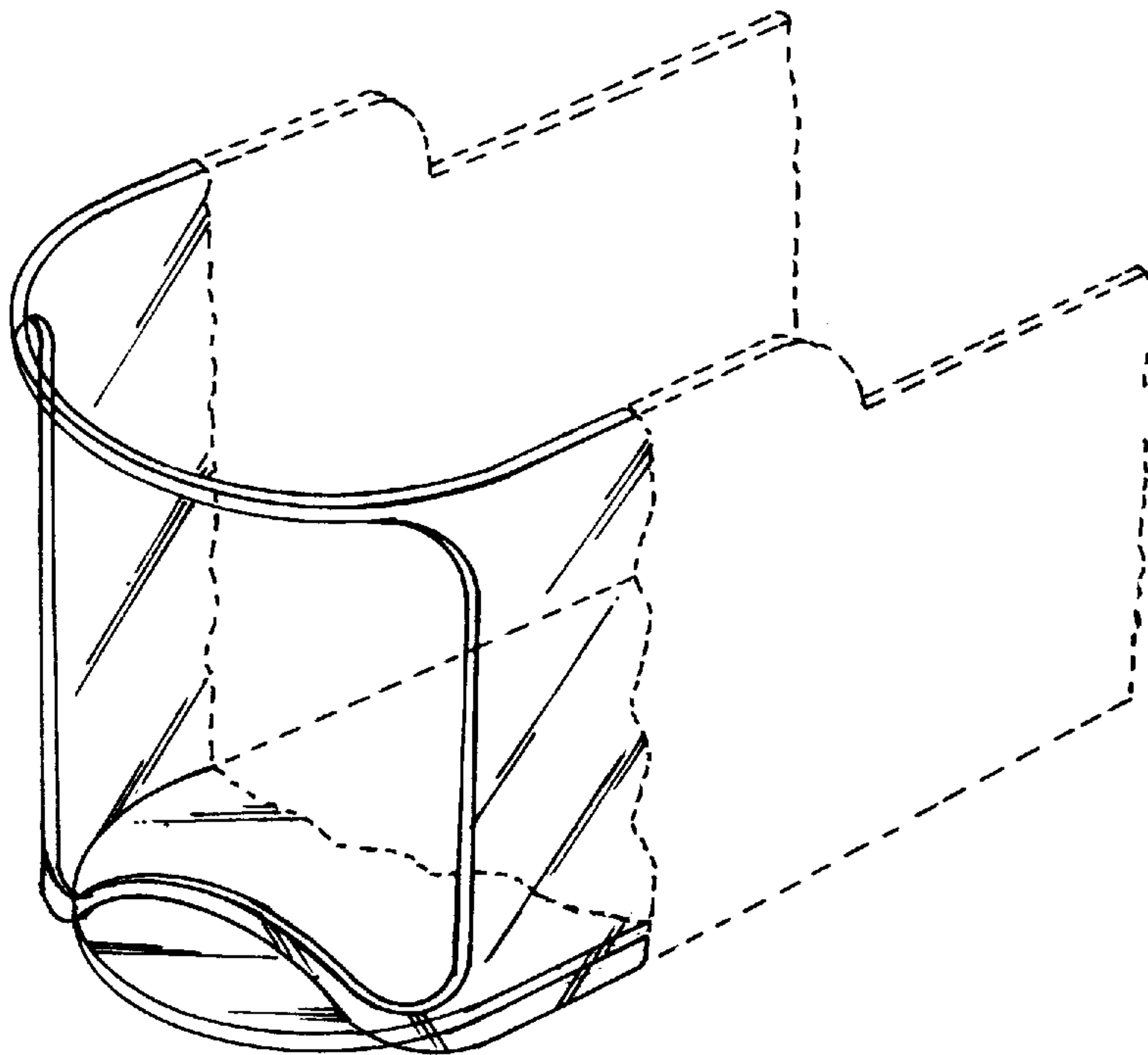

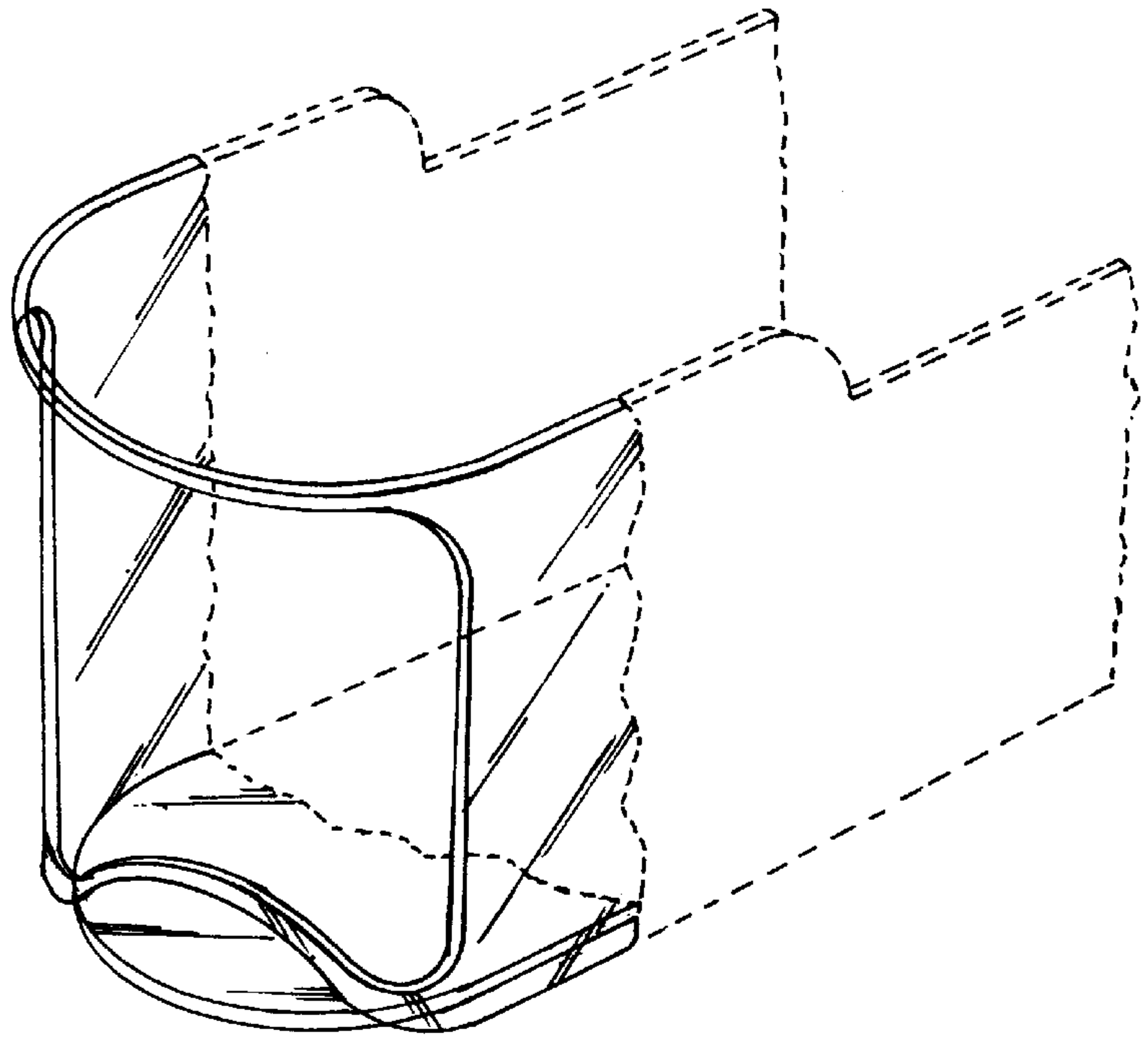

FIG. 1

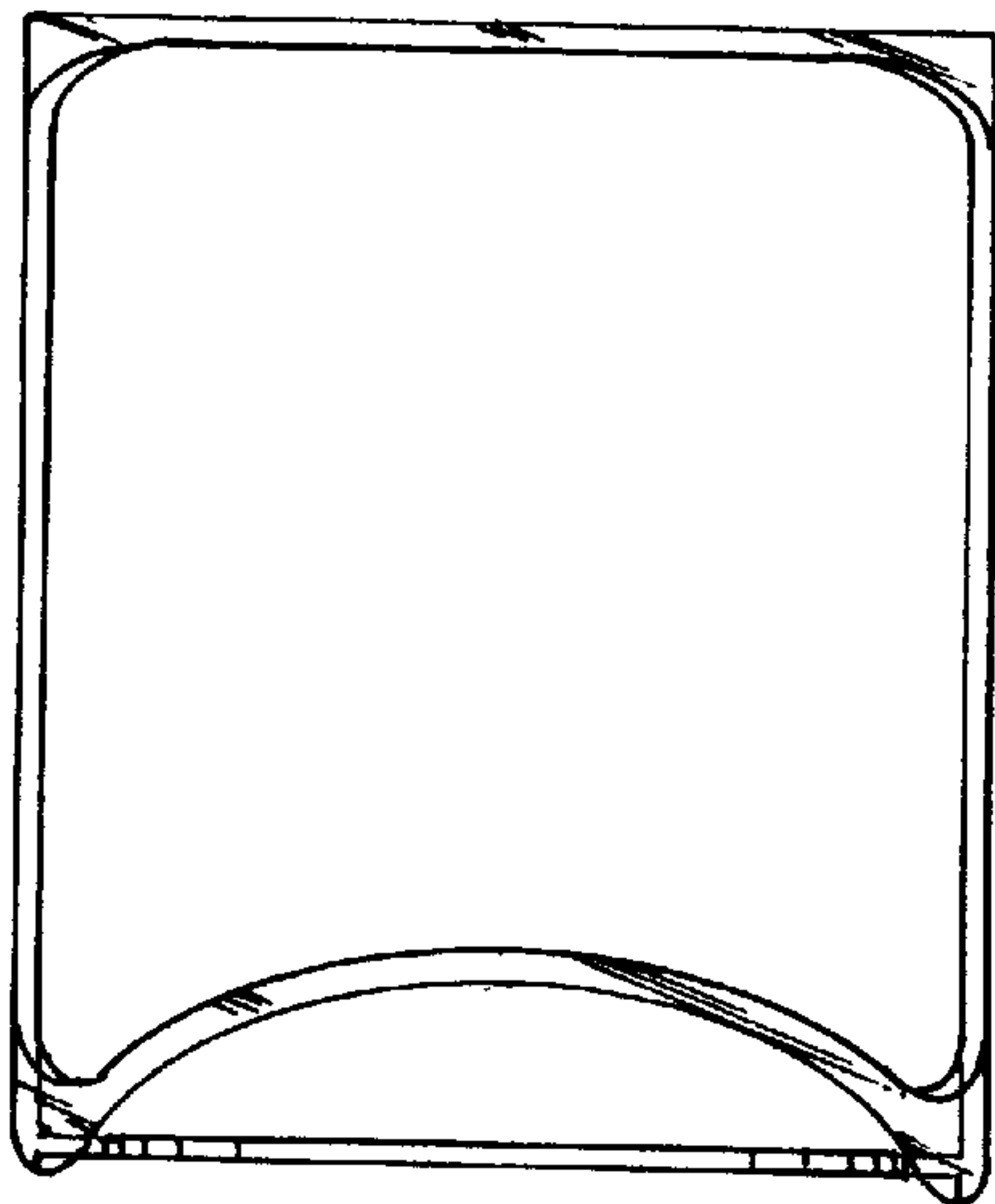

FIG. 2

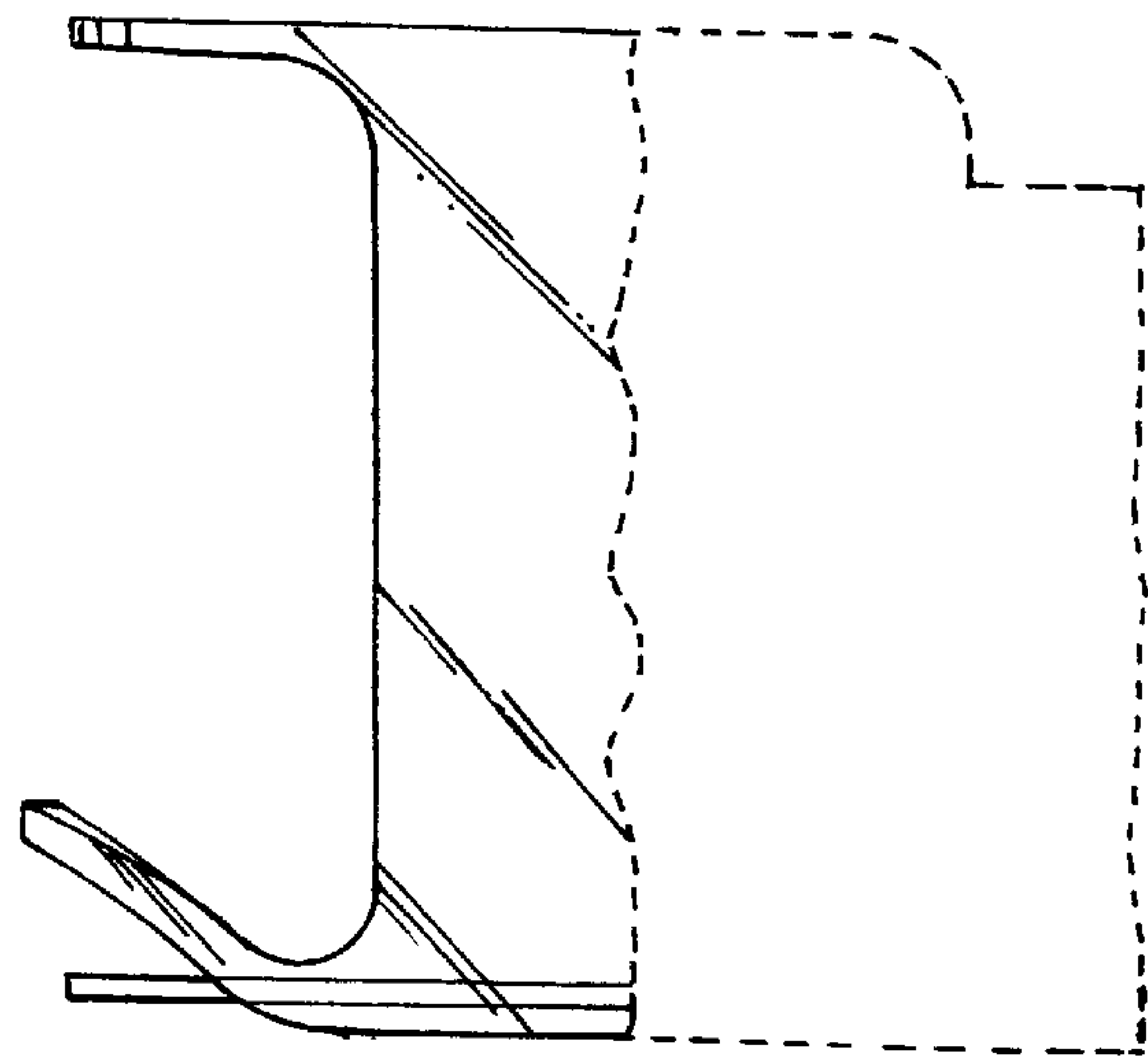

FIG. 3

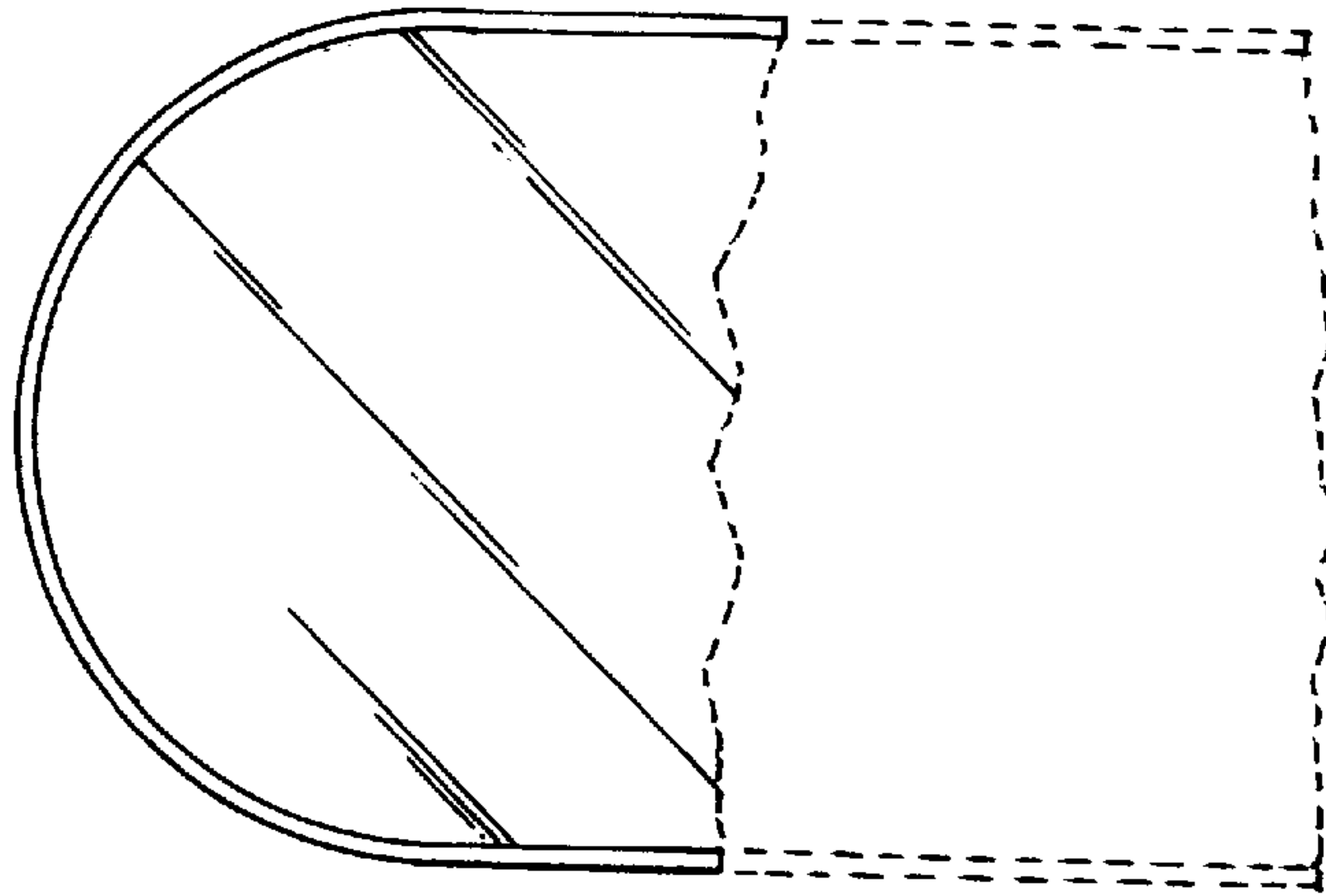

FIG. 4

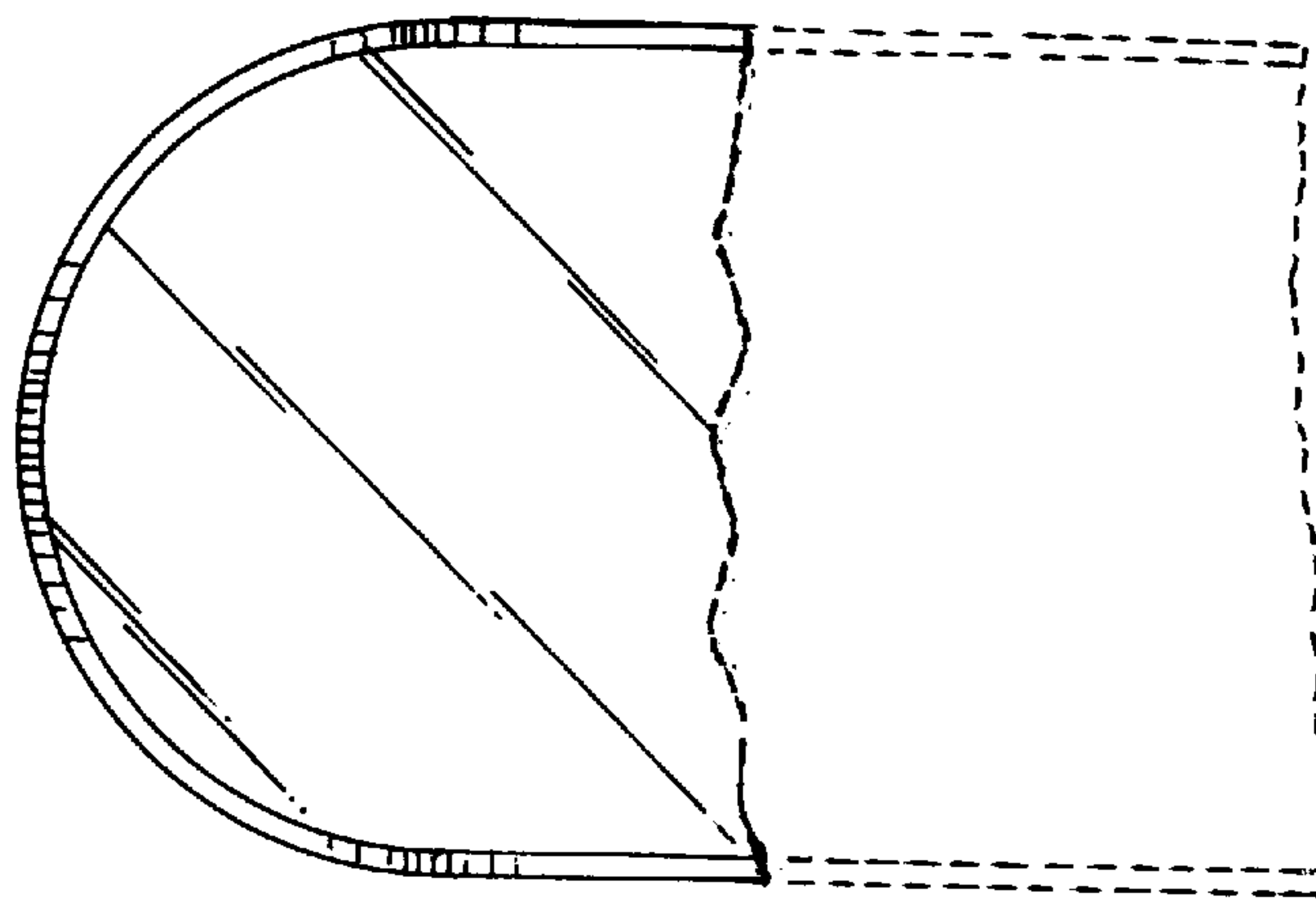

FIG. 5