



US00D401298S

United States Patent [19]
Portzline

[11] **Patent Number: Des. 401,298**

[45] **Date of Patent: **Nov. 17, 1998**

[54] **HUB FOR A SKATE WHEEL**

[75] Inventor: **Scott Portzline**, Portland, Oreg.

[73] Assignee: **Nike, Inc.**, Beaverton, Oreg.

[**] Term: **14 Years**

[21] Appl. No.: **69,184**

[22] Filed: **Apr. 14, 1997**

[51] **LOC (6) Cl.** **21-02**

[52] **U.S. Cl.** **D21/779**

[58] **Field of Search** D2/904, 946, 970;
D12/204, 207, 208; D21/222; 36/45, 50.1,
114, 115; 280/11.19, 11.2, 11.22, 11.26,
11.27, 11.28, 809, 841, 843, 87.1; 301/5.3,
5.7

4,114,952 9/1978 Kimmell 301/5.7
5,046,746 9/1991 Gierveld 280/11.22
5,271,633 12/1993 Hill, Jr. 280/11.22
5,478,140 12/1995 Racosky 301/5.7
5,567,019 10/1996 Raza et al. 301/5.3
5,573,309 11/1996 Bekessy 301/5.3
5,580,093 12/1996 Conway 280/816
5,630,891 5/1997 Peterson et al. 280/11.22
5,660,447 8/1997 Angelici 280/11.22

OTHER PUBLICATIONS

“Inline Skate Wheel Primer”, *Sports Etc. Magazine*, Apr., 1997.

Primary Examiner—Sandra L. Morris
Attorney, Agent, or Firm—Klarquist Sparkman Campbell Leigh & Winston, LLP.

[57] **CLAIM**

The ornamental design for a hub for a skate wheel, as shown and described.

DESCRIPTION

FIG. 1 is a left side view of a hub for a skate wheel in accordance with my invention;

FIG. 2 is a right side view of the hub for a skate wheel of FIG. 1;

FIG. 3 is a front view of the hub for a skate wheel of FIG. 1, the views from the rear, top, and bottom being the same as the front view; and,

FIG. 4 is a right side perspective view thereof.

The broken lines indicate the skate wheel is for illustrative purposes only and form no part of the claimed design.

[56] **References Cited**

U.S. PATENT DOCUMENTS

D. 225,989 1/1973 Chadwick D12/207
D. 248,748 8/1978 Siroonian D12/207
D. 330,883 11/1992 Harr D12/207
D. 384,718 10/1997 Lee D21/226
503,233 8/1893 Frankenberg .
555,501 3/1896 Fergguson .
823,939 6/1906 Everett .
873,874 12/1907 Leitch .
884,720 4/1908 Curtis .
939,451 11/1909 Spacie .
1,532,784 4/1925 Staples .
1,989,338 1/1935 Ruske .
3,302,954 2/1967 Elwell 280/11.19
3,992,025 11/1976 Amelio 280/87.04

1 Claim, 2 Drawing Sheets

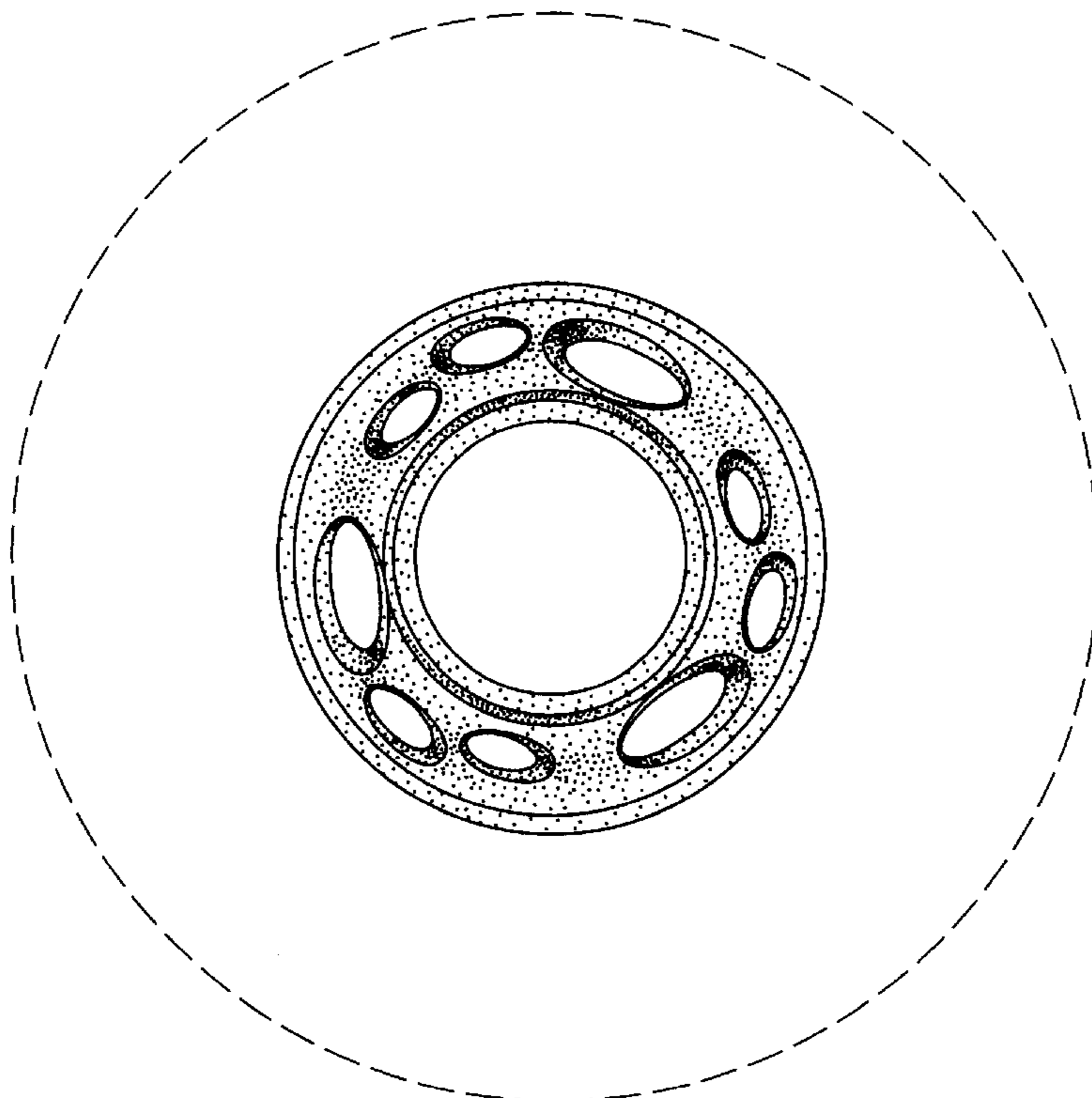

FIG. 1

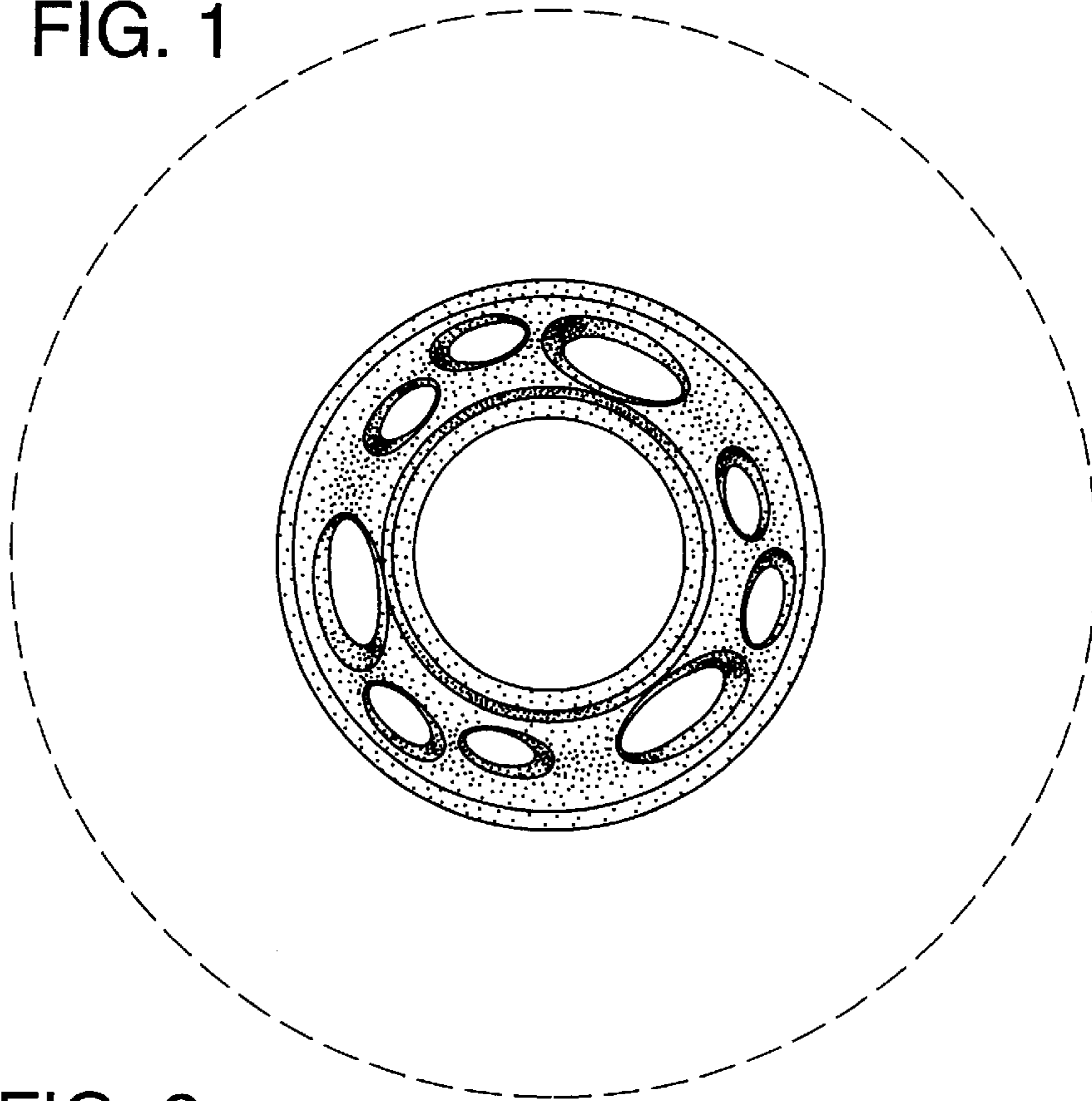

FIG. 2

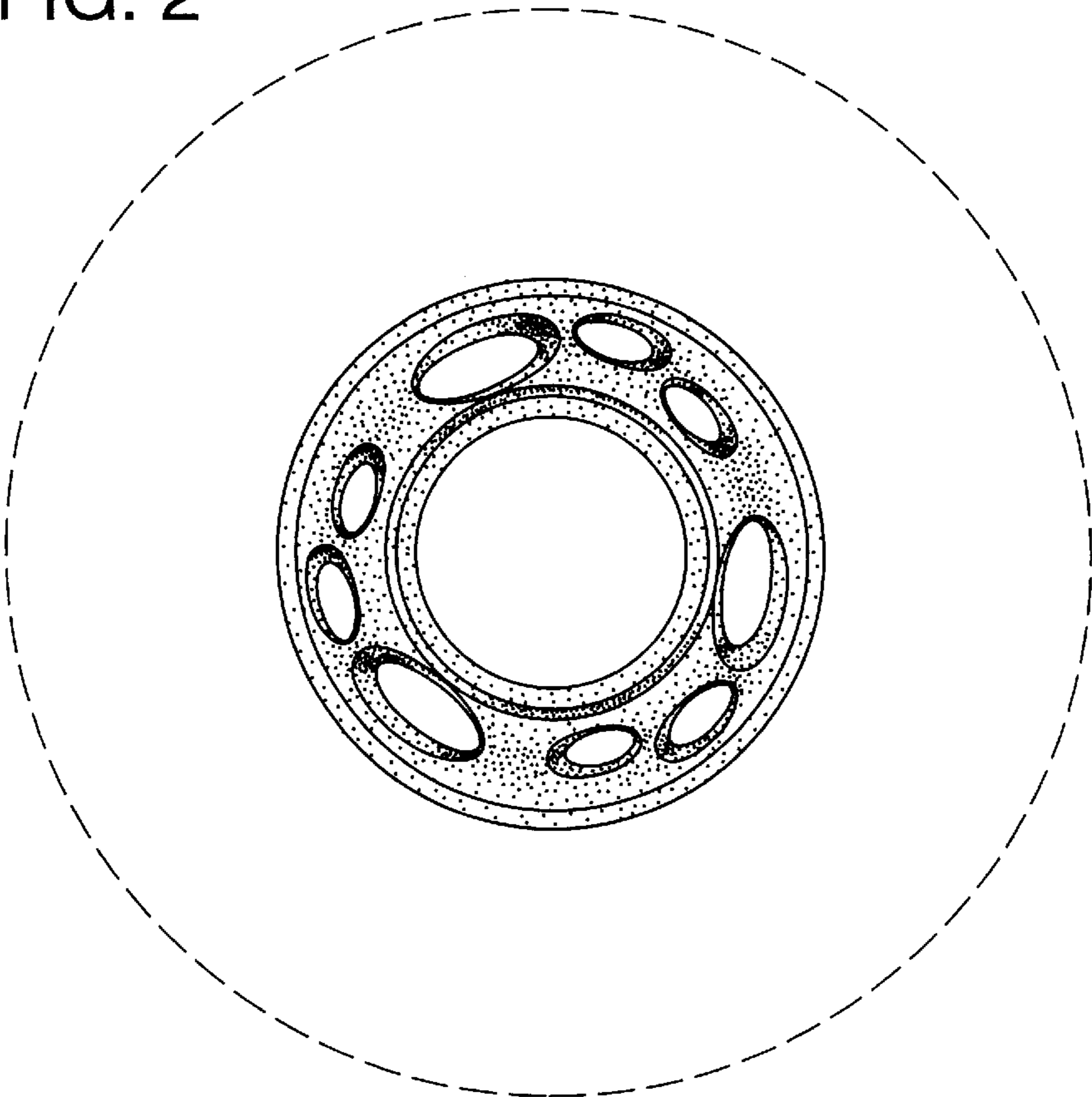

FIG. 3

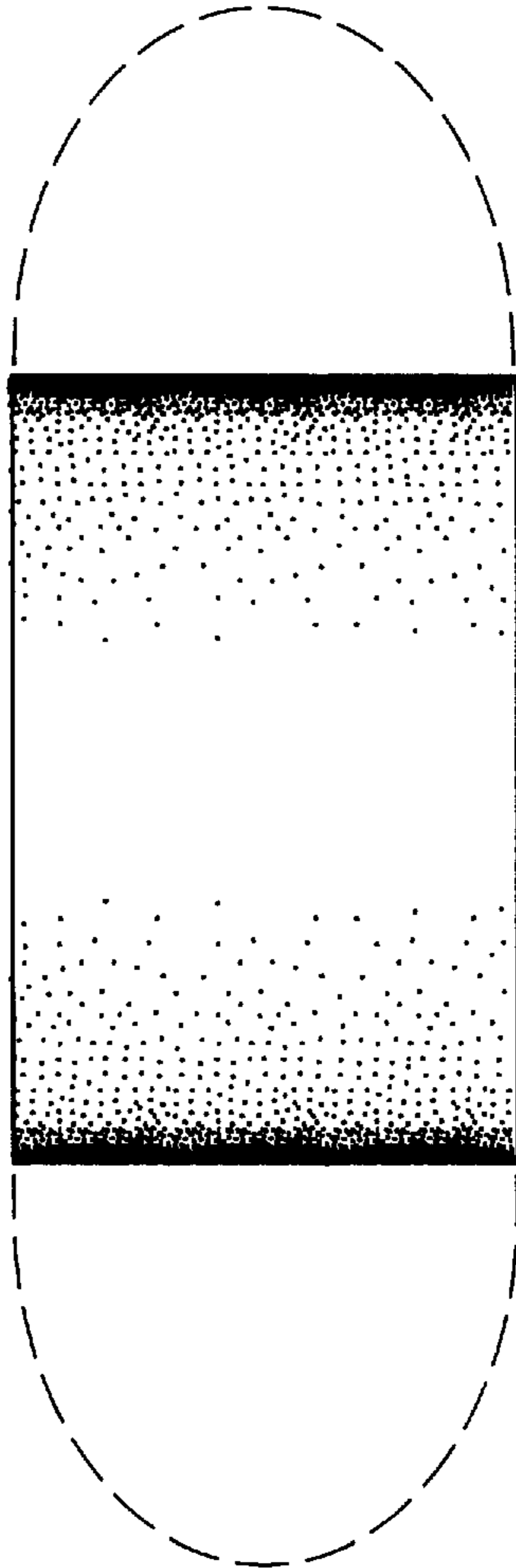

FIG. 4

