



US00D401213S

United States Patent [19] Inchaurregui

[11] Patent Number: **Des. 401,213**

[45] Date of Patent: ****Nov. 17, 1998**

[54] **VEHICLE RIFLE MOUNT**

[75] Inventor: **Rory Daniel Inchaurregui**, Loomis, Calif.

[73] Assignee: **Inch's Tooling & Machining**, Loomis, Calif.

[**] Term: **14 Years**

[21] Appl. No.: **81,589**

[22] Filed: **Jan. 7, 1998**

[51] **LOC (6) Cl.** **12-16**

[52] **U.S. Cl.** **D12/406; D6/552**

[58] **Field of Search** D12/406, 415, D12/416-418; D3/254, 262, 901; 224/311, 913, 916, 324, 42.11; 211/64, 86, 99-100; 296/37.6, 37.13, 37.16; D6/552

[56] **References Cited**

U.S. PATENT DOCUMENTS

D. 310,446	9/1990	Elkins	D12/406 X
D. 356,541	3/1995	Morford	D12/406
D. 365,717	1/1996	Cardenas	D6/552
D. 371,107	6/1996	Summers	D12/406
4,132,315	1/1979	Young	211/64
4,579,263	4/1986	Ehmke et al.	211/64
4,852,780	8/1989	Woodbury	224/913 X
4,936,531	6/1990	Bauser	224/42.11
4,986,427	1/1991	Law et al.	211/64
4,991,723	2/1991	Elkins	211/64
5,287,972	2/1994	Saathoff	211/64
5,595,333	1/1997	Boston	224/536
5,626,379	5/1997	Scott	294/143

Primary Examiner—Jeffrey Asch
Assistant Examiner—Stacia Sinuik
Attorney, Agent, or Firm—Heisler & Associates

[57] **CLAIM**

The ornamental design for a vehicle rifle mount, as shown and described.

DESCRIPTION

FIG. 1 is a perspective view of a lower portion of a vehicle rifle mount according to this invention;

FIG. 2 is a right side view of the lower portion of the invention, it being understood that portions of this FIGURE shown with broken lines are for illustrative purposes only and form no part of the claimed design;

FIG. 3 is a front elevation view of the lower portion of the invention;

FIG. 4 is a top plan view of the lower portion of the invention;

FIG. 5 is a left side view of the lower portion of the invention;

FIG. 6 is a rear elevation view of the lower portion of the invention;

FIG. 7 is a bottom plan view of the lower portion of the invention;

FIG. 8 is a perspective view of an upper portion of the vehicle rifle mount of this invention;

FIG. 9 is a front elevation view of the upper portion of the invention;

FIG. 10 is a rear elevation view of the upper portion of the invention;

FIG. 11 is a bottom plan view of the upper portion of the invention;

FIG. 12 is a top plan view of the upper portion of the invention;

FIG. 13 is a right side view of the upper portion of the invention;

FIG. 14 is a top right side view of the upper portion of the invention taken along lines 14—14 of FIG. 9;

FIG. 15 is a perspective view of the vehicle rifle mount of this invention in position within an automobile, it being understood that portions of this FIGURE shown with broken lines are for illustrative purposes only and form no part of the claimed design.

The lower portion and the upper portion of the vehicle rifle mount have been shown separately in FIGS. 1-7 and 8-14 respectively, for convenience of illustration.

1 Claim, 6 Drawing Sheets

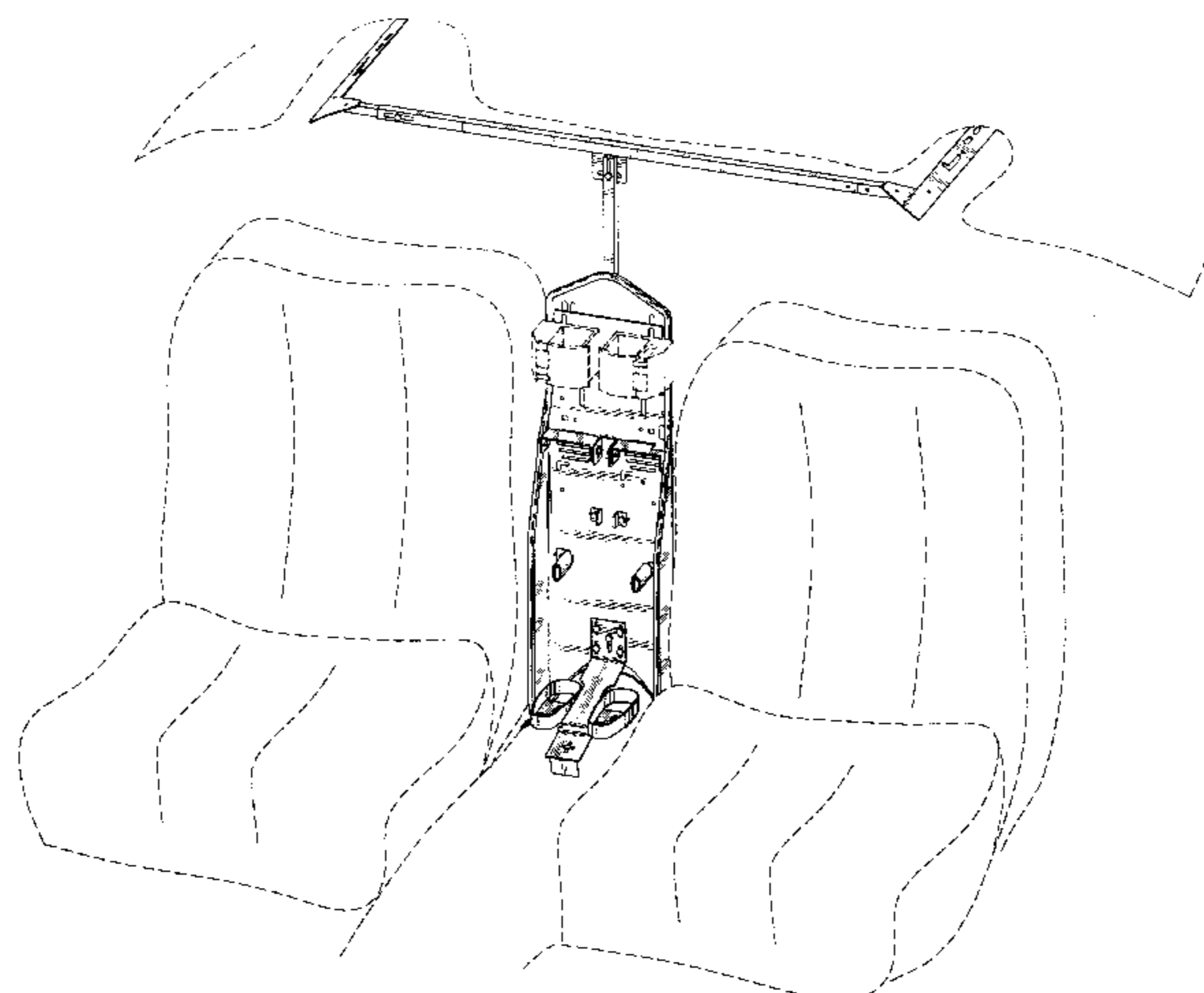

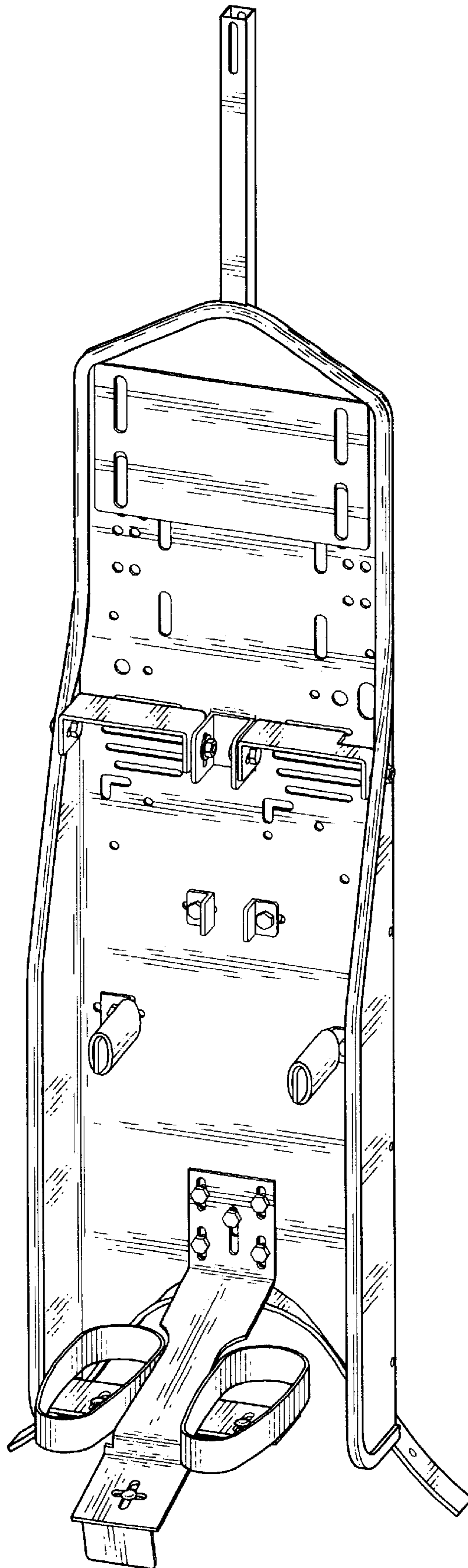

Fig. 1

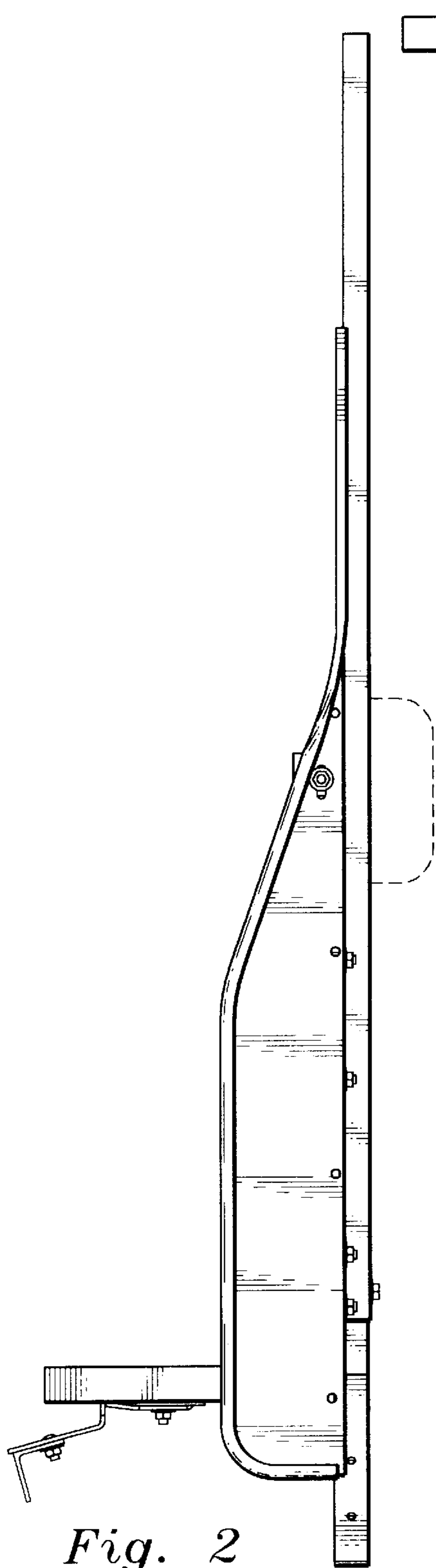

Fig. 2

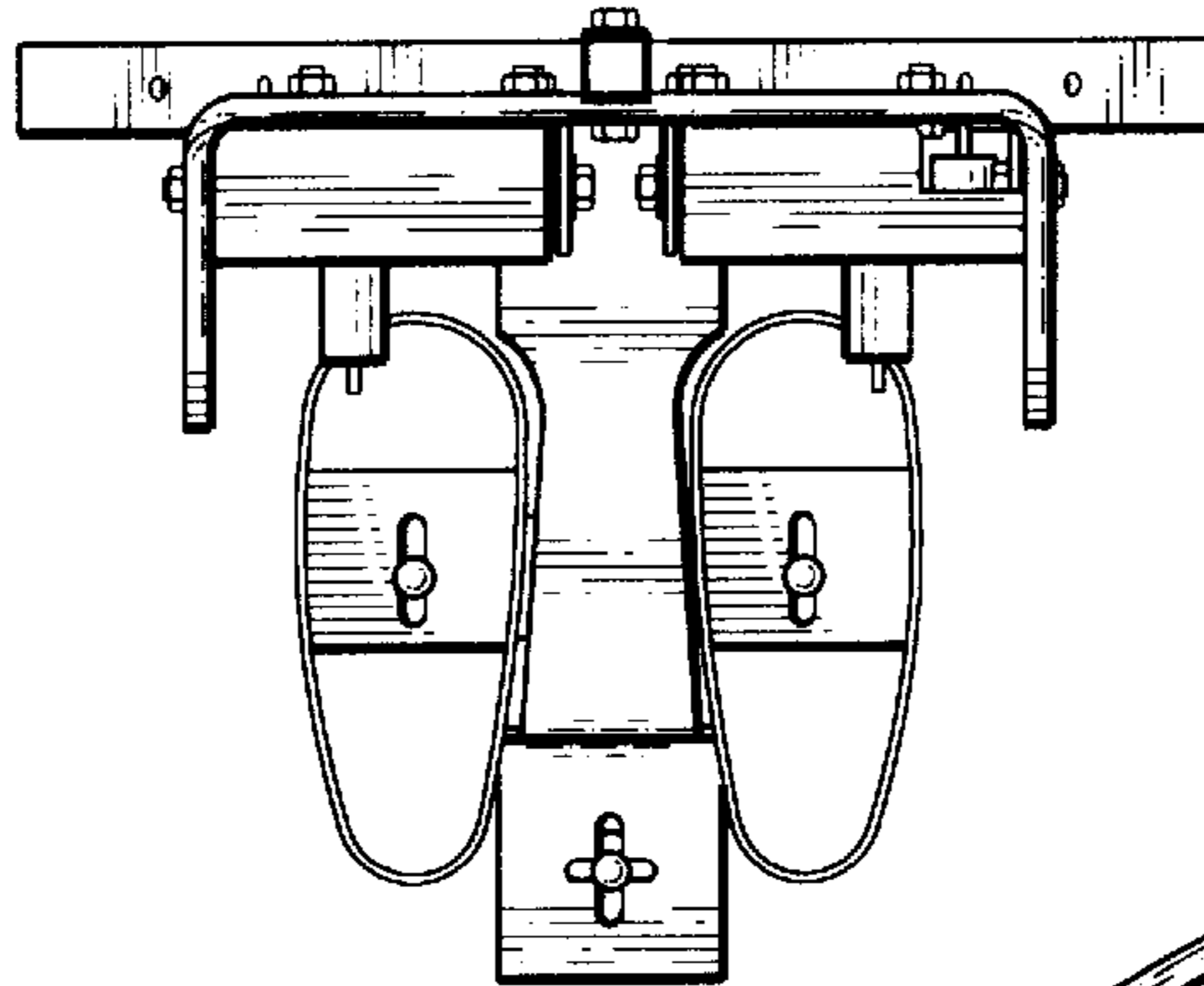

Fig. 4

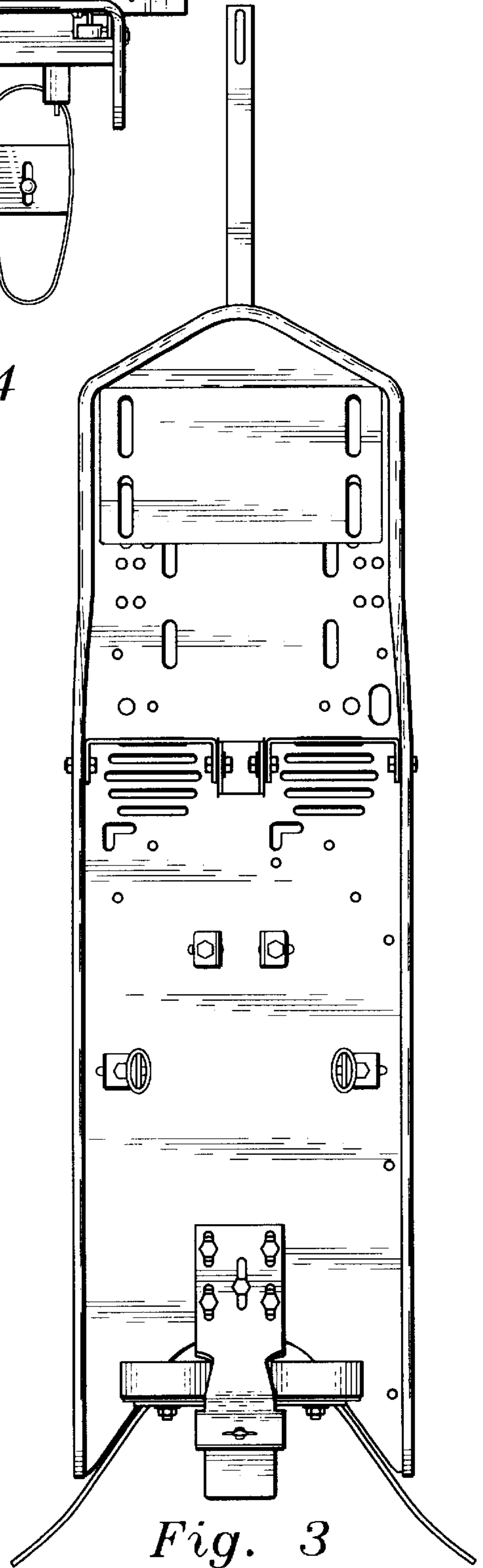
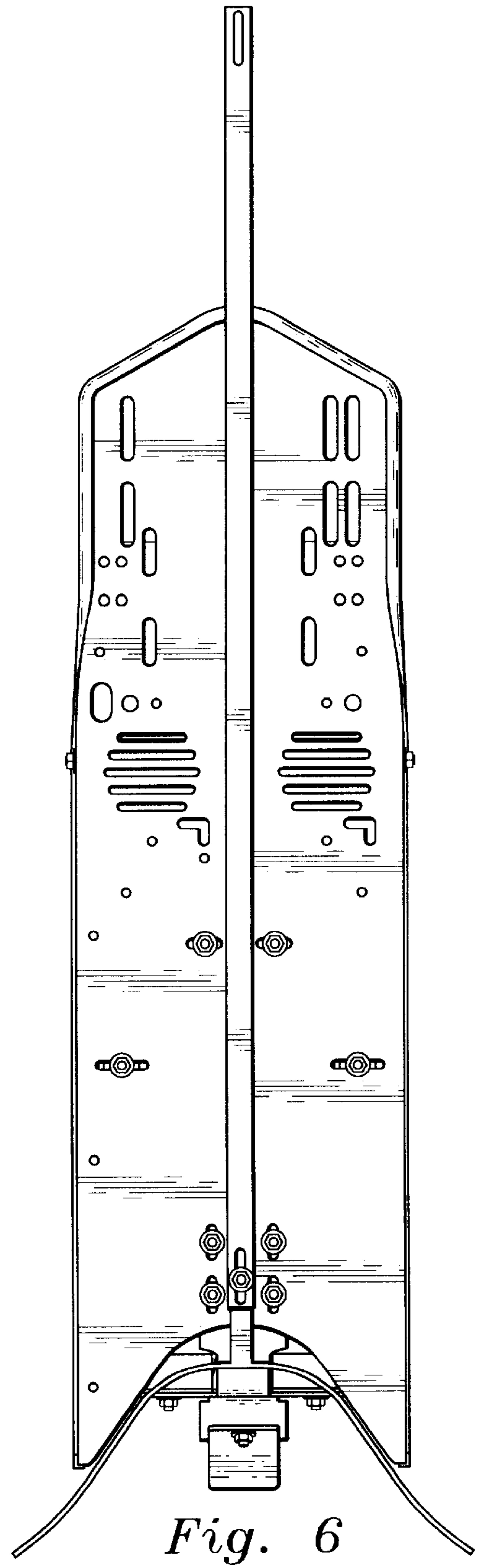
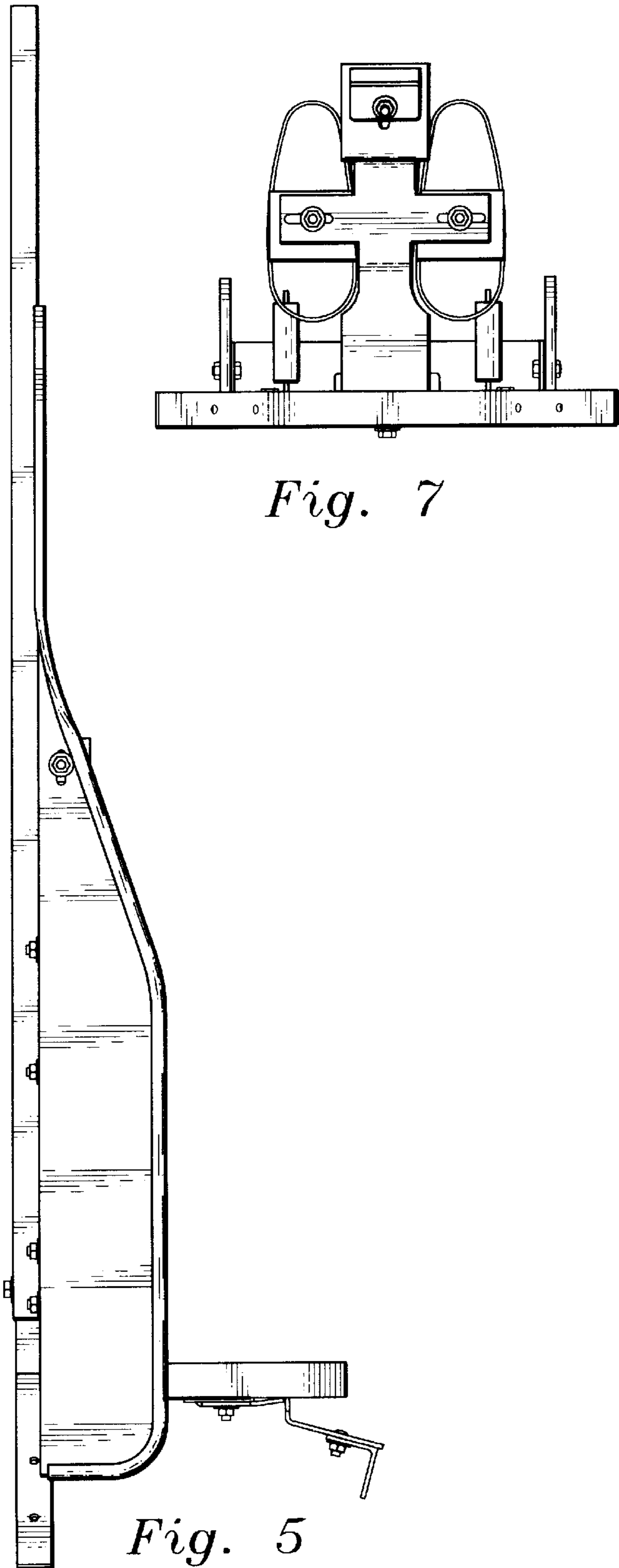

Fig. 3



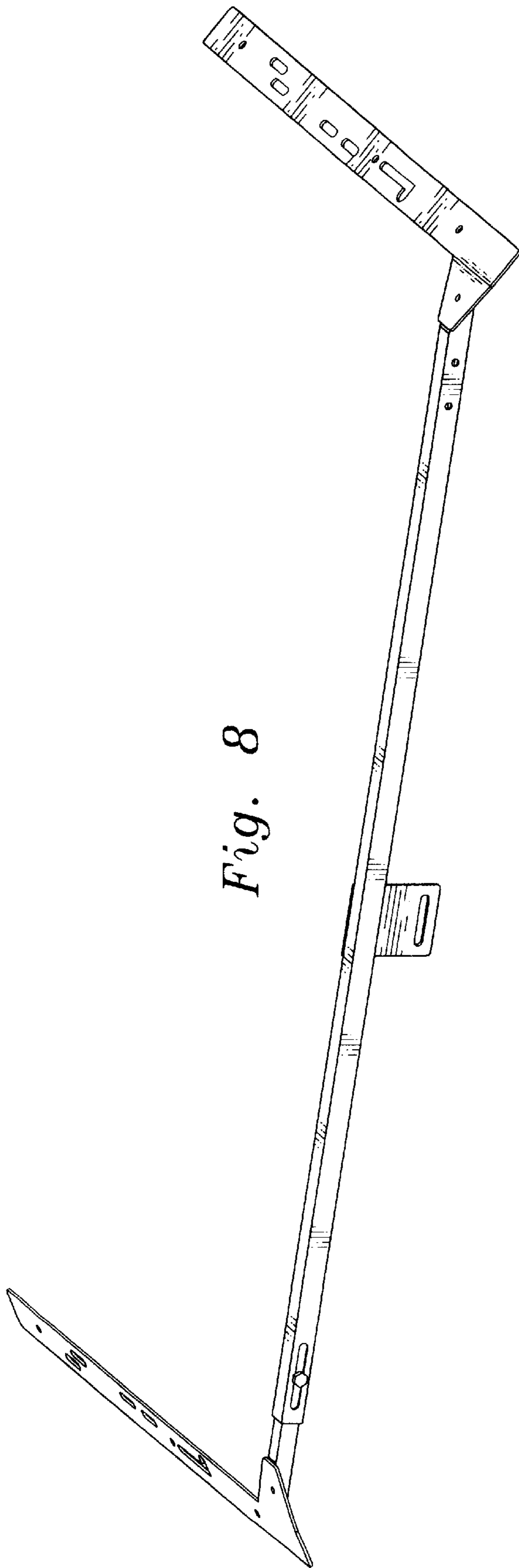

Fig. 8

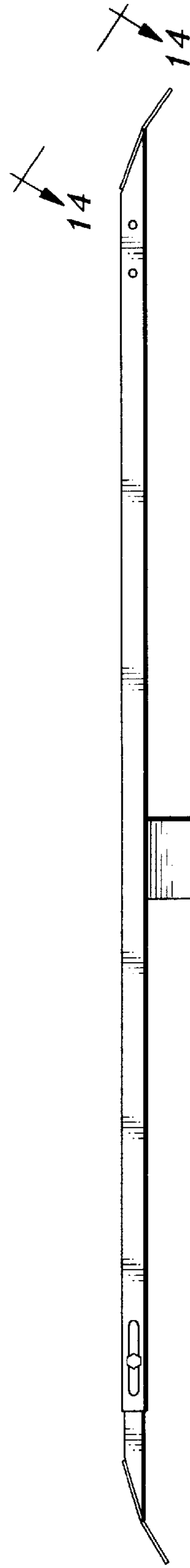

Fig. 9



Fig. 10

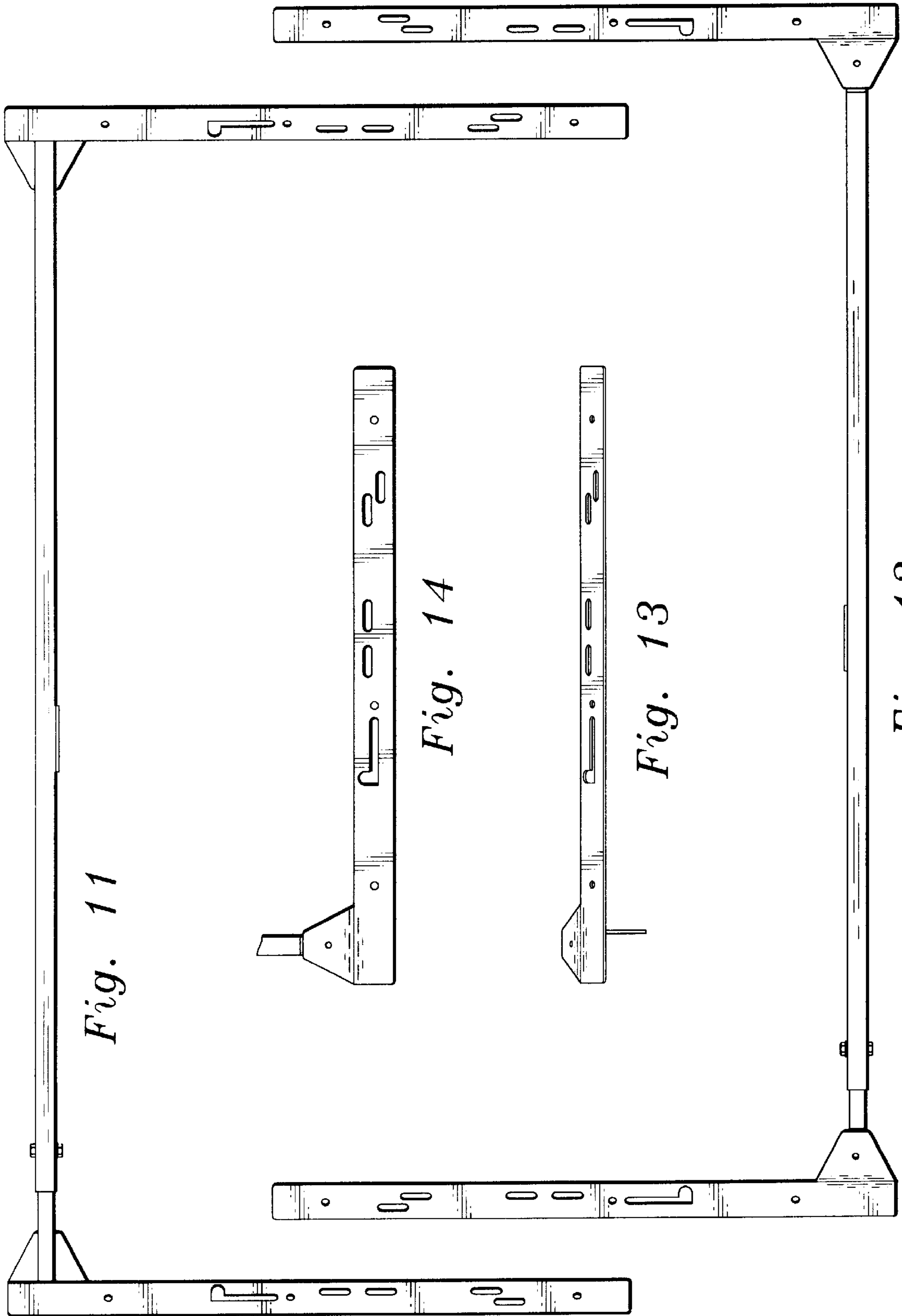

Fig. 11

Fig. 14

Fig. 13

Fig. 12

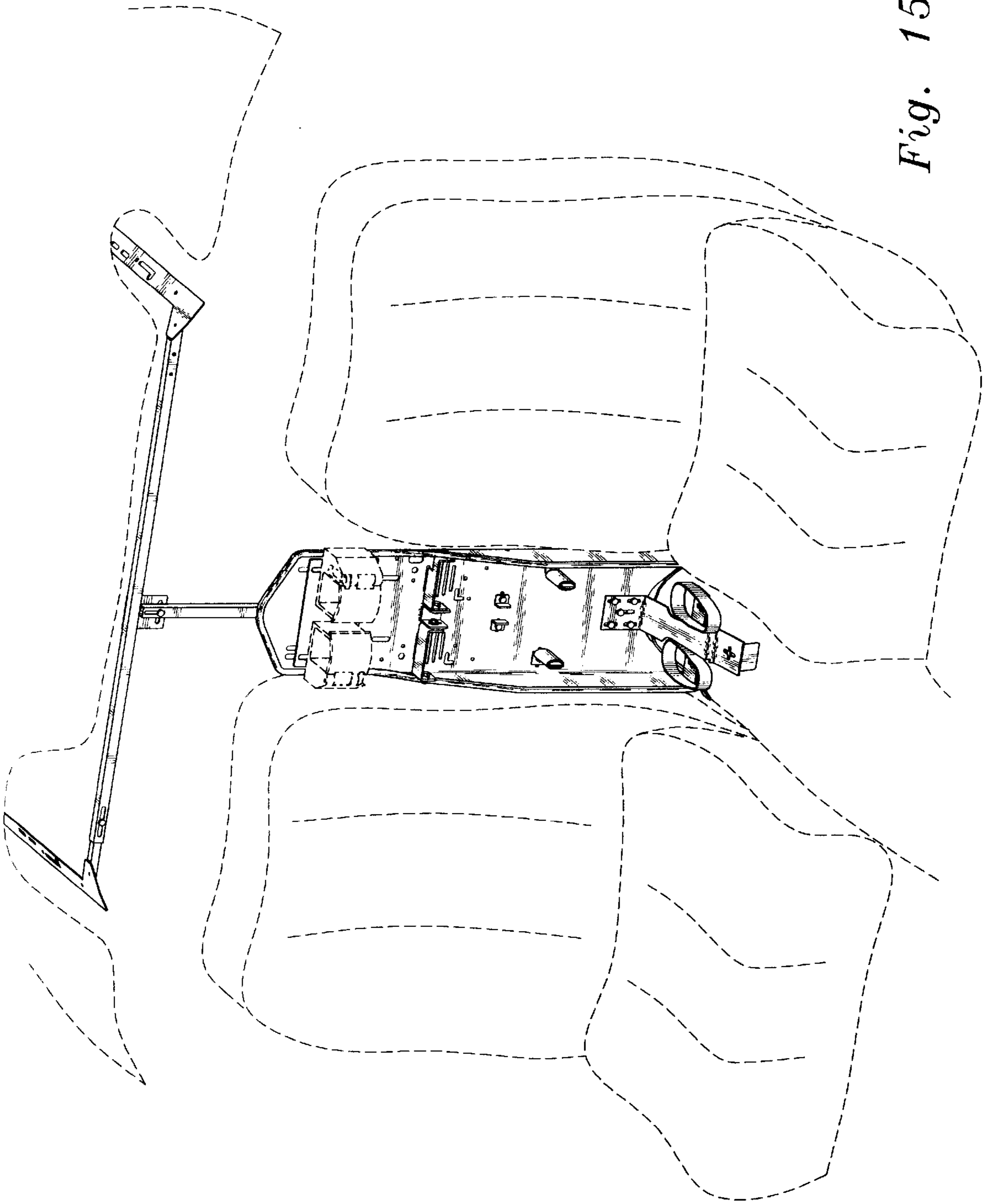

Fig. 15