



US00D401212S

United States Patent [19]
Tapolsky et al.

[11] **Patent Number: Des. 401,212**
[45] **Date of Patent: **Nov. 17, 1998**

[54] **PERSONAL WATERCRAFT**

DESCRIPTION

[75] Inventors: **Bruno A. Tapolsky**, Sausalito; **Michael R. Hector**, Tiburon; **Curt A. Bitter**, Sausalito; **Timothy S. Wadleigh**, Novato, all of Calif.

[73] Assignee: **Stealth Performance Corp.**, San Rafael, Calif.

[**] Term: **14 Years**

[21] Appl. No.: **63,570**

[22] Filed: **Dec. 10, 1996**

[51] **LOC (6) Cl.** **12-06**

[52] **U.S. Cl.** **D12/307**

[58] **Field of Search** D12/300-318;
114/270, 271, 56

[56] **References Cited**

U.S. PATENT DOCUMENTS

D. 340,221	10/1993	Kreiger et al.	D12/307
D. 342,931	1/1994	Mordikian	D12/307
D. 350,324	9/1994	Miller	D12/307
D. 359,265	6/1995	Leiva	D12/307
5,501,168	3/1996	Zachary	114/363

Primary Examiner—Kay H. Chin
Attorney, Agent, or Firm—Pennie & Edmonds LLP

[57] **CLAIM**

The ornamental design for a personal watercraft, as shown and described.

FIG. 1 is a left side elevational view of a first embodiment of our new personal watercraft design;
 FIG. 2 is a right side elevational view thereof;
 FIG. 3 is a front elevational view thereof;
 FIG. 4 is a rear elevational view thereof;
 FIG. 5 is a top plan view thereof;
 FIG. 6 is a bottom plan view thereof;
 FIG. 7 is a perspective view thereof, taken from the front left side;
 FIG. 8 is a left side elevational view of a second embodiment of our new personal watercraft design;
 FIG. 9 is a right side elevational view thereof;
 FIG. 10 is a front elevational view thereof;
 FIG. 11 is a rear elevational view thereof;
 FIG. 12 is a top plan view thereof;
 FIG. 13 is a bottom plan view thereof;
 FIG. 14 is a perspective view thereof, taken from the front left side;
 FIG. 15 is a left side elevational view of a third embodiment of our new personal watercraft design;
 FIG. 16 is a right side elevational view thereof;
 FIG. 17 is a front elevational view thereof;
 FIG. 18 is a rear elevational view thereof;
 FIG. 19 is a top plan view thereof;
 FIG. 20 is a bottom plan view thereof; and,
 FIG. 21 is a perspective view thereof, taken from the front left side.

The broken line structures shown in FIGS. 8 through 21 are for illustrative purposes only and form no part of the second and third embodiments.

1 Claim, 12 Drawing Sheets

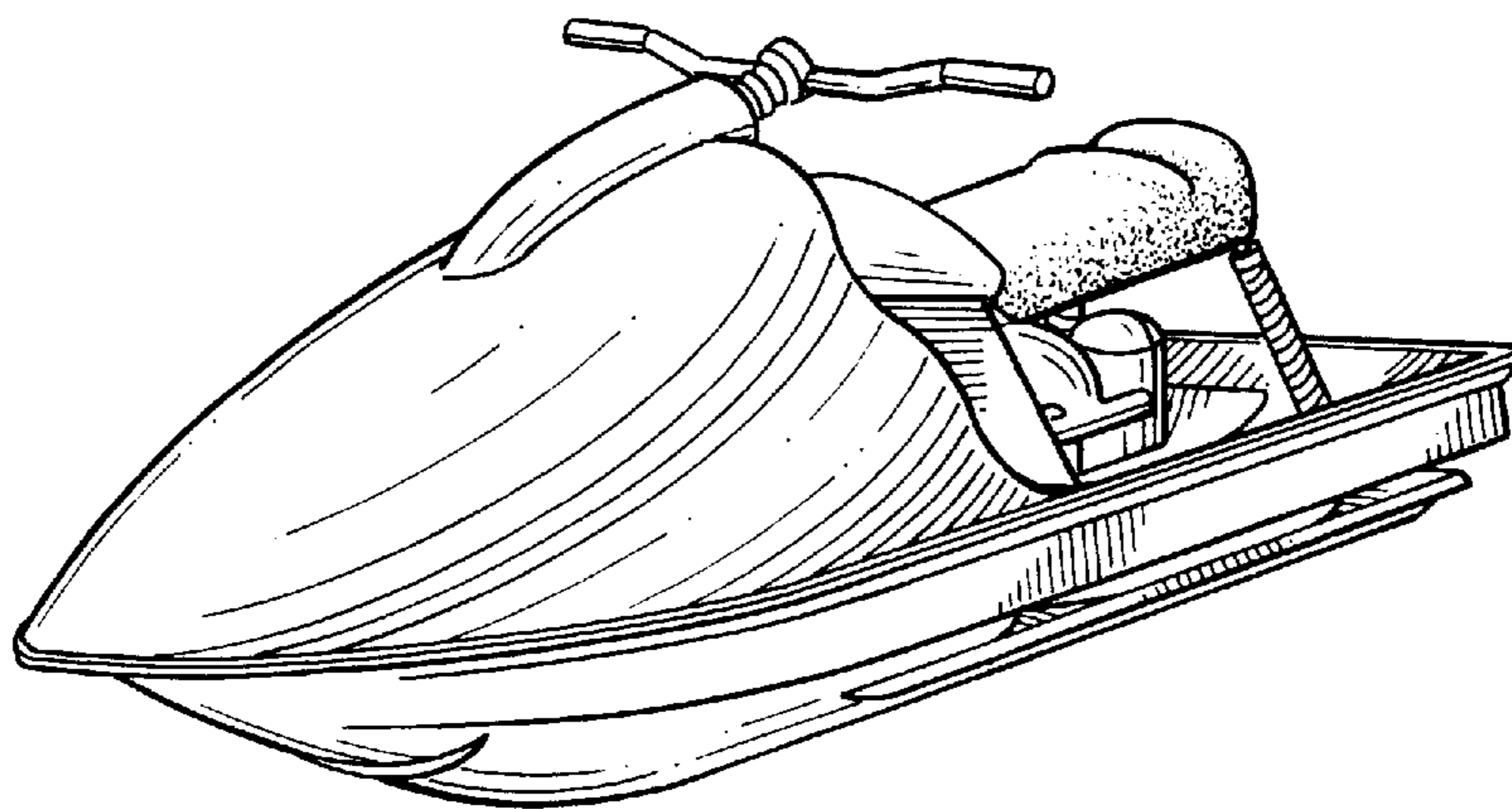

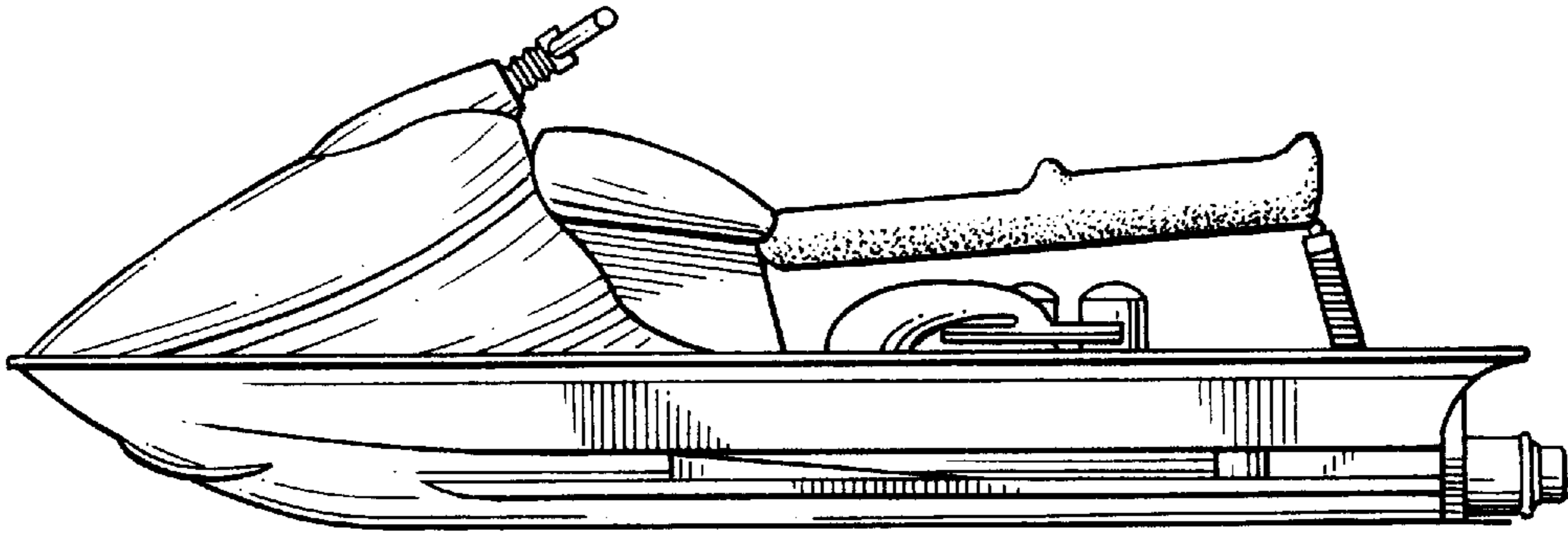

FIG. 1

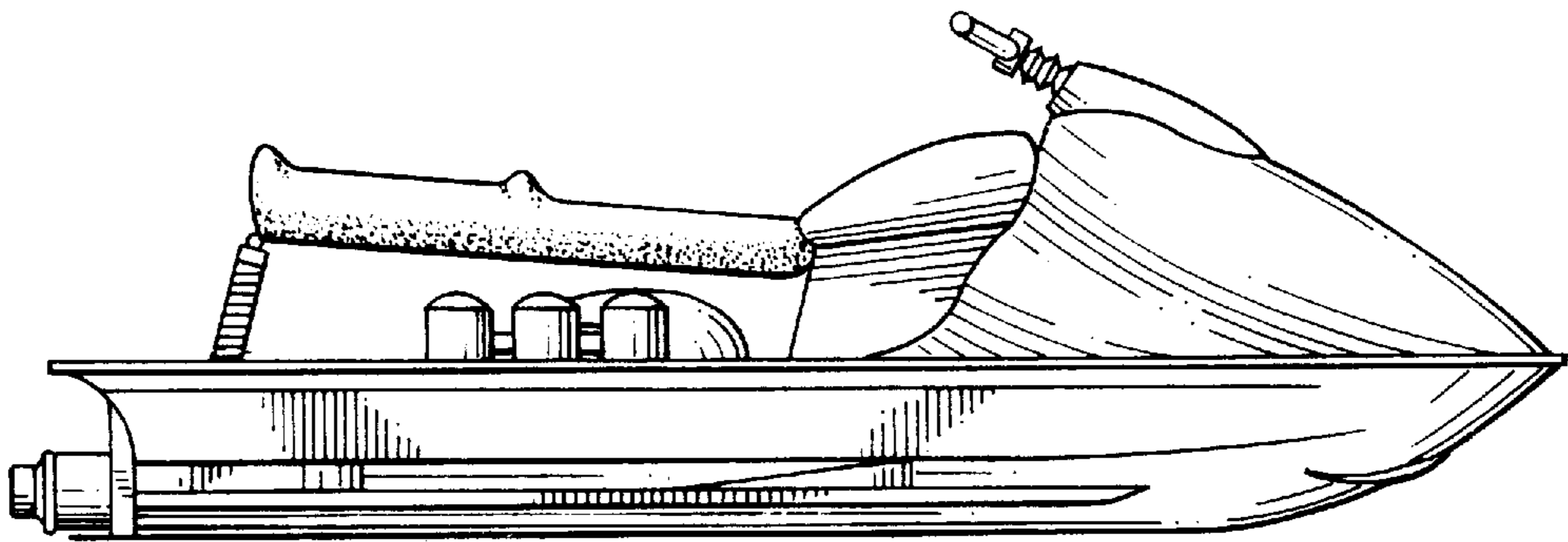

FIG. 2

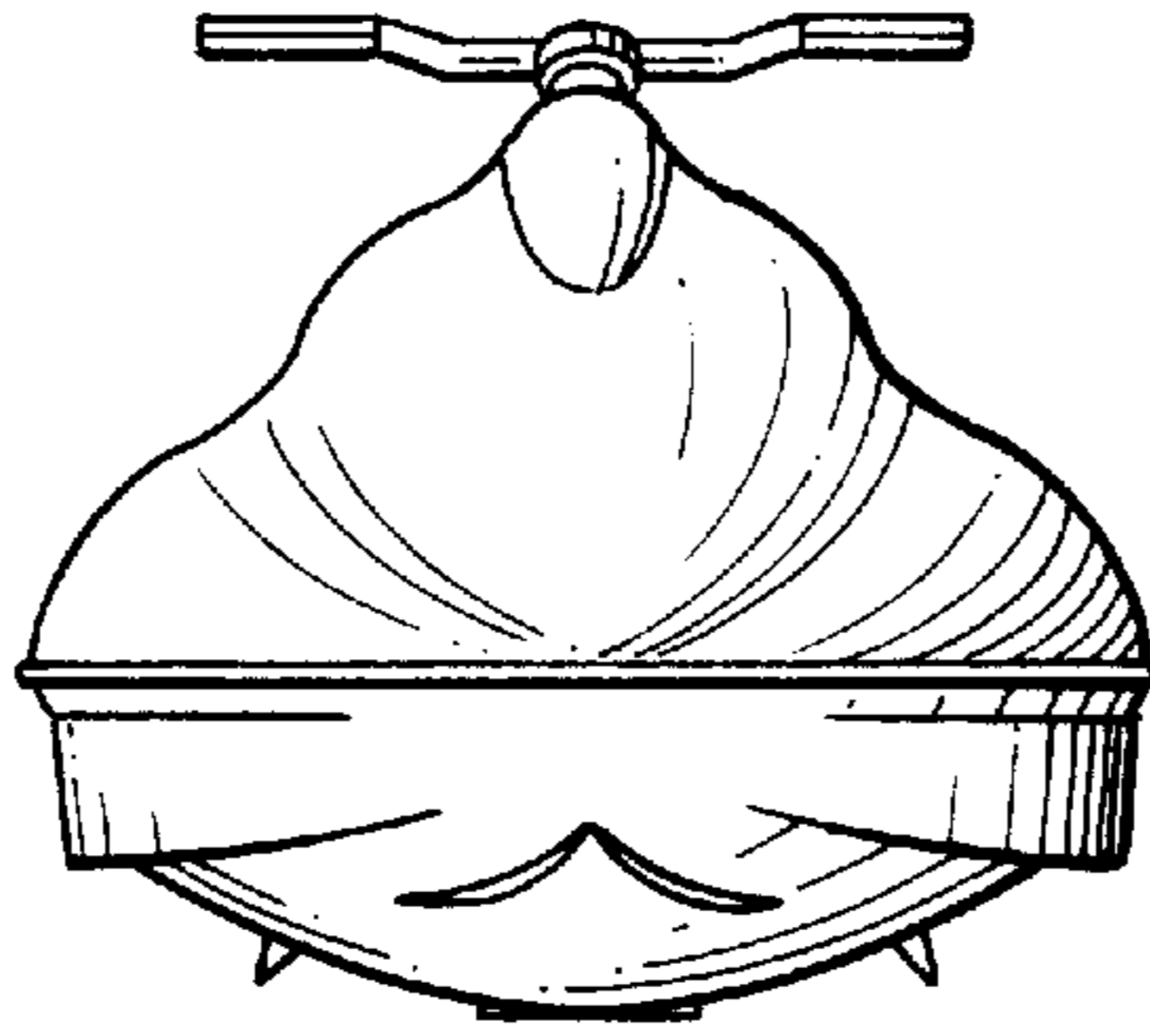

FIG. 3

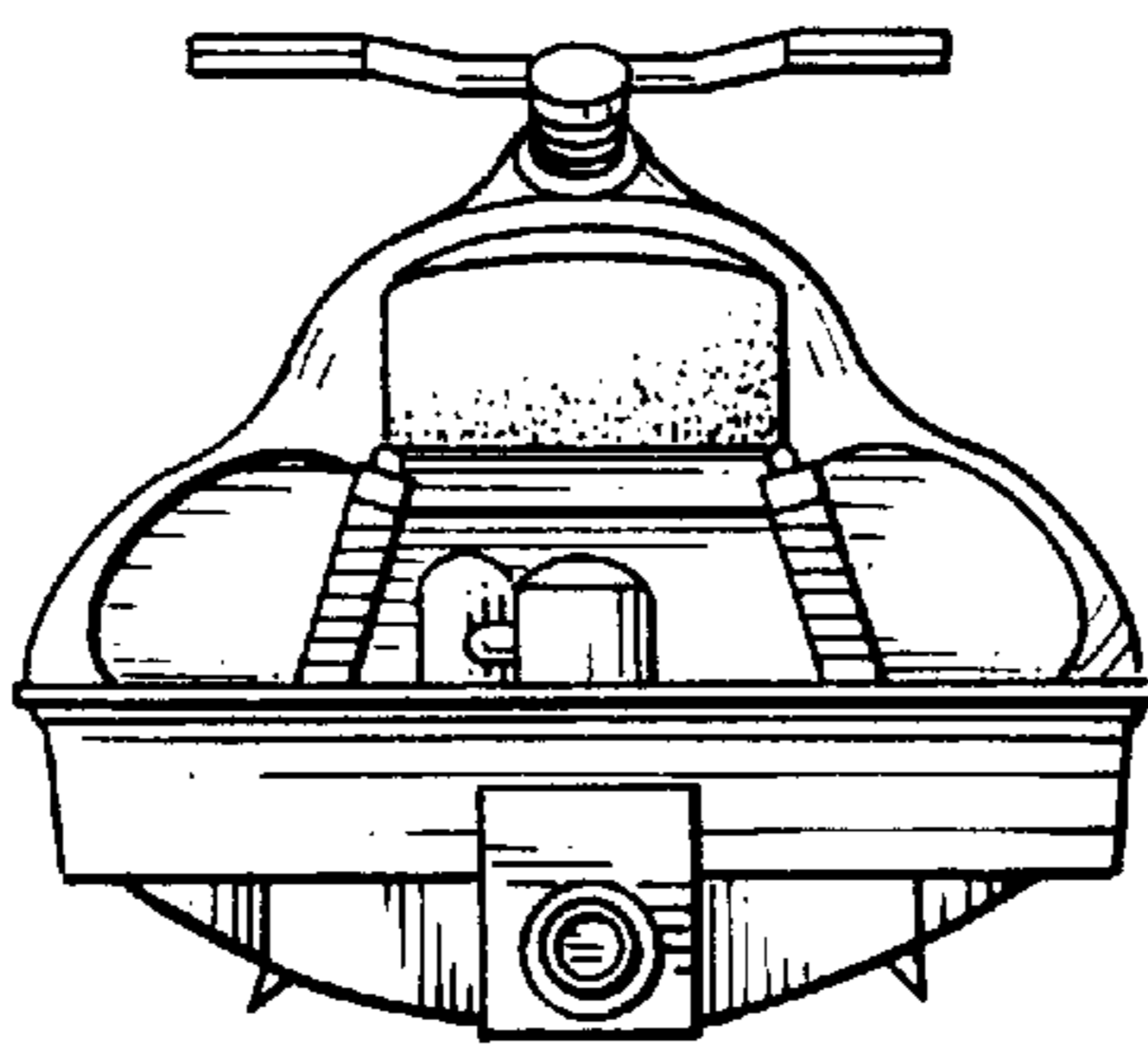

FIG. 4

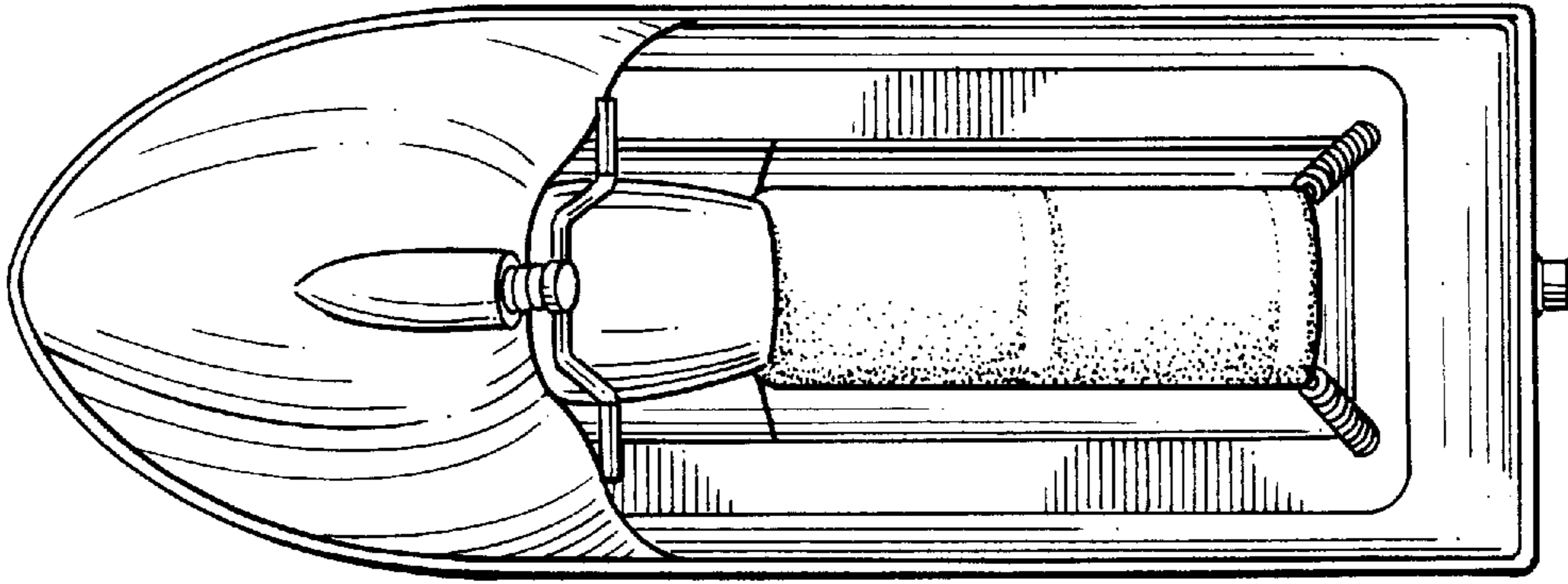

FIG. 5

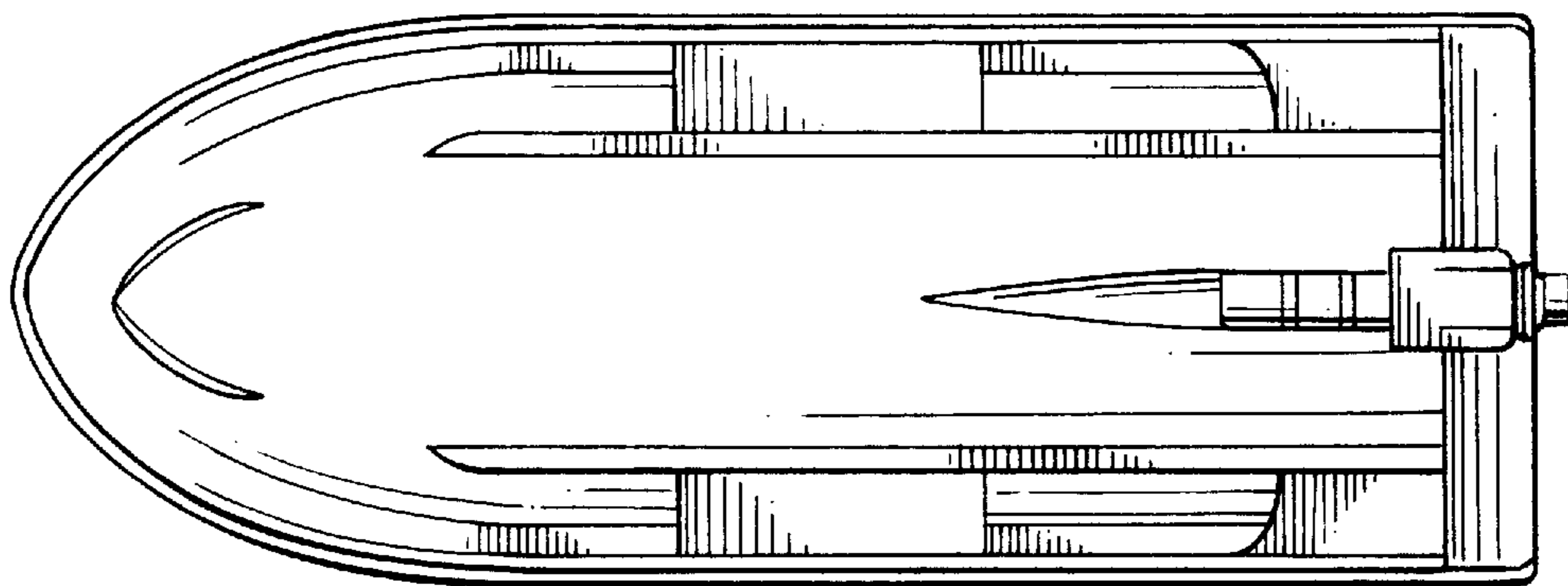

FIG. 6

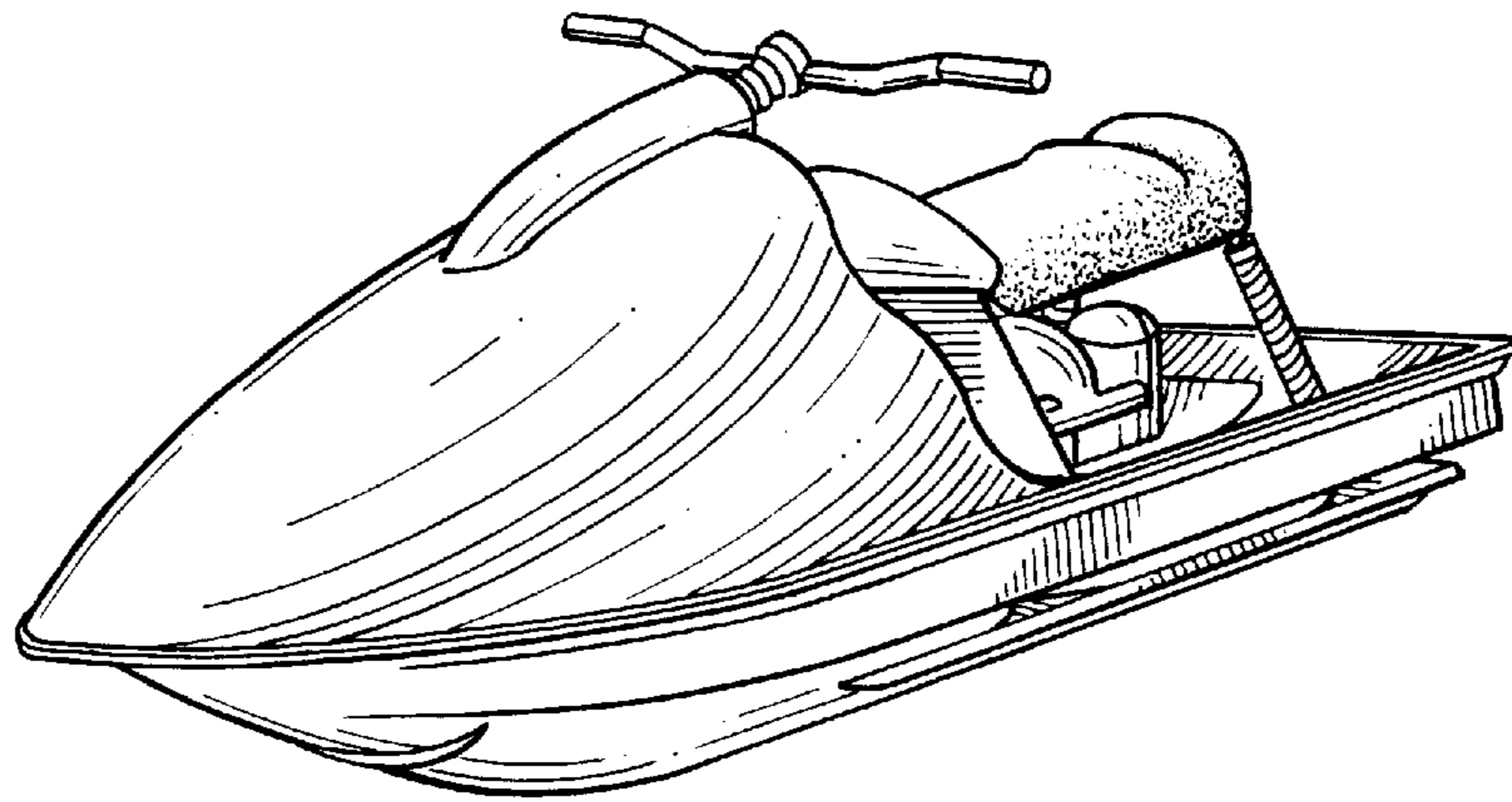

FIG. 7

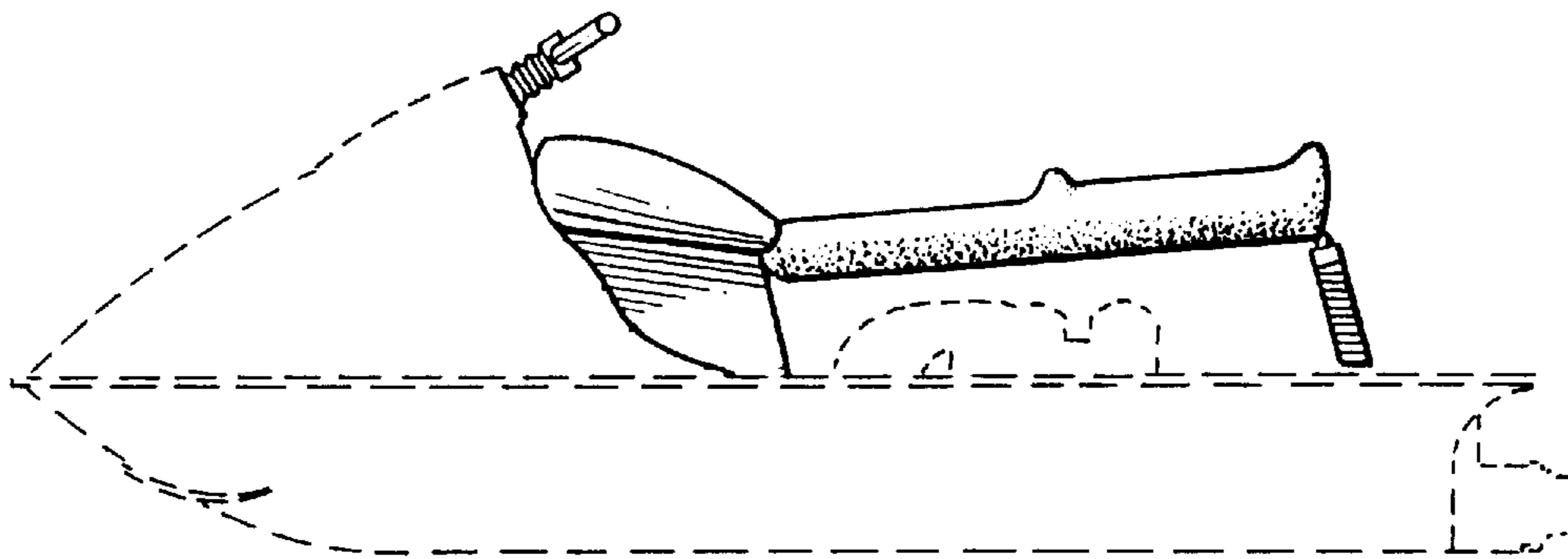

FIG. 8

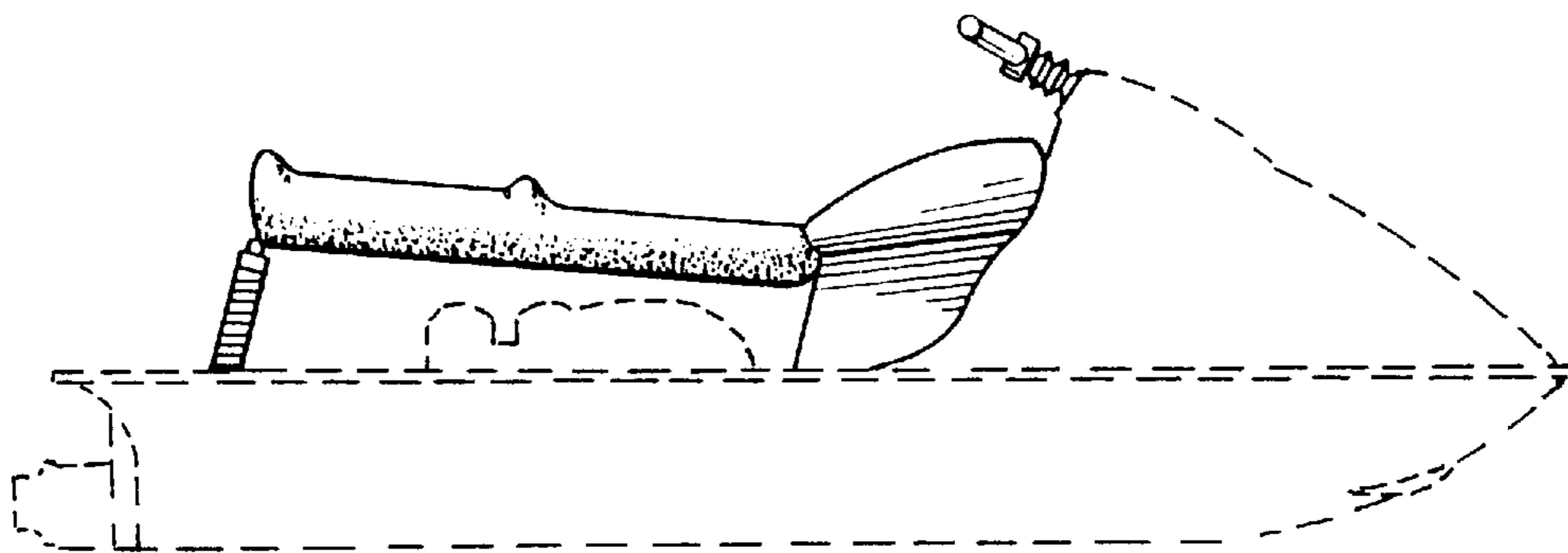

FIG. 9

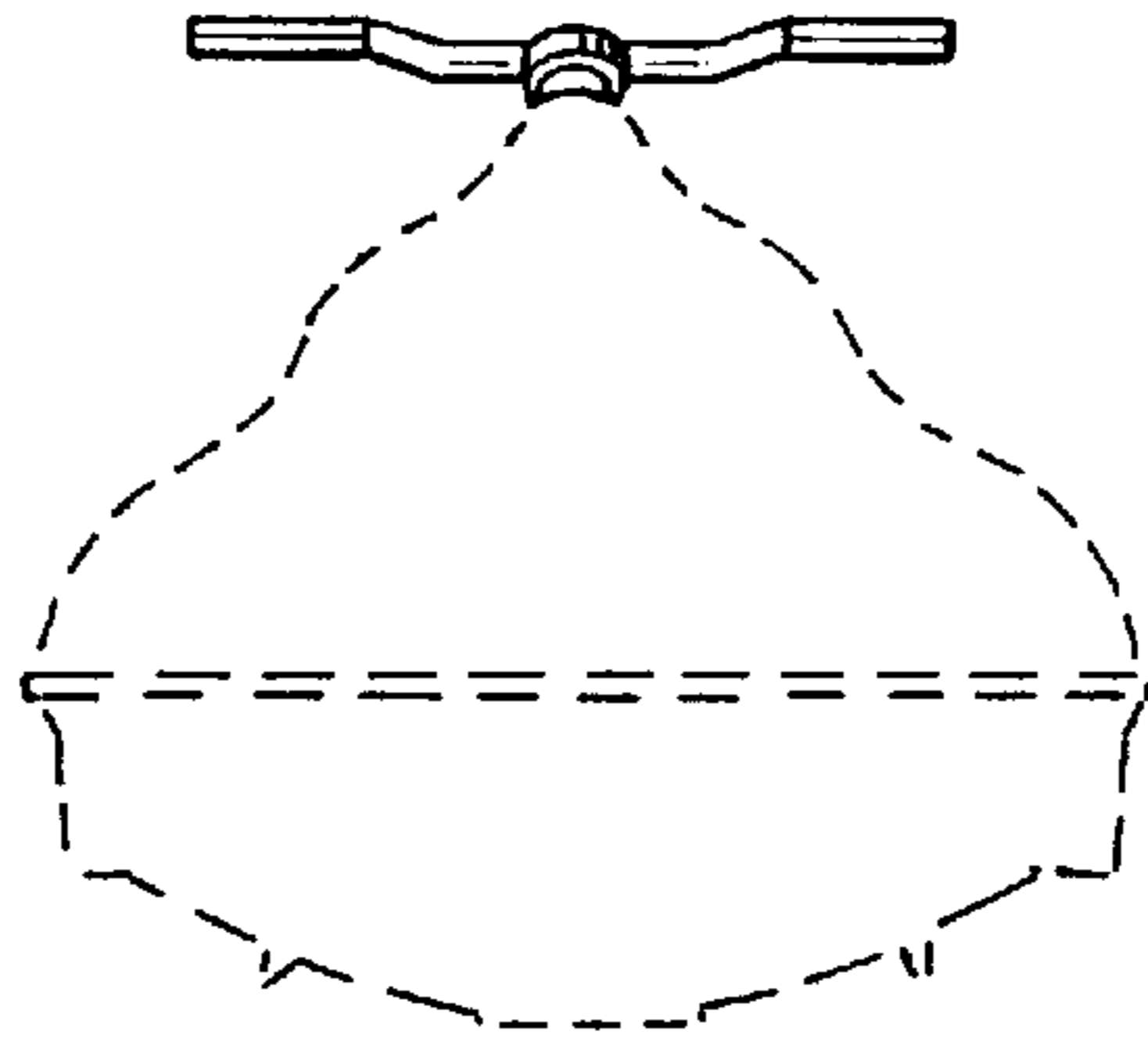

FIG. 10

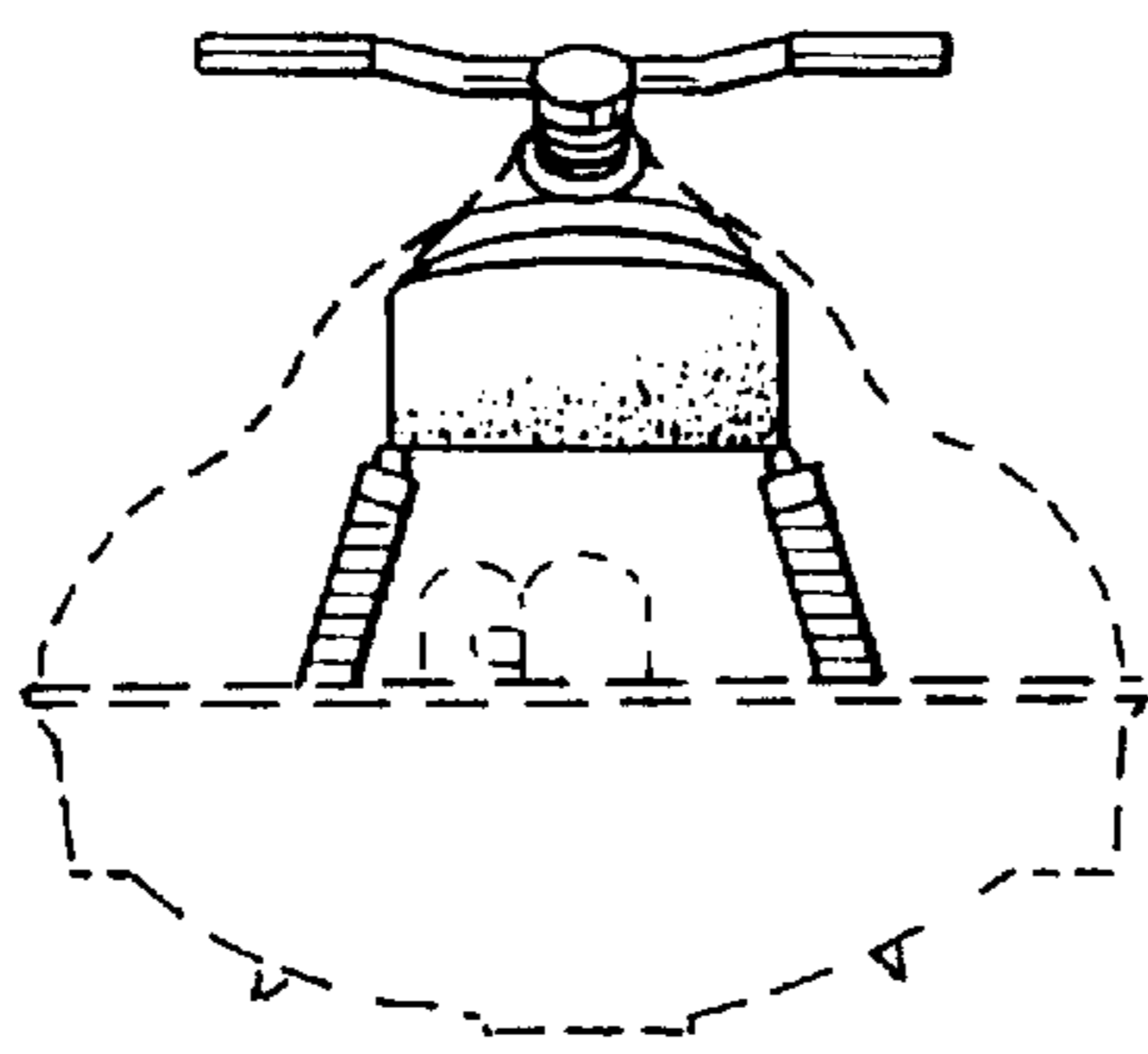

FIG. 11

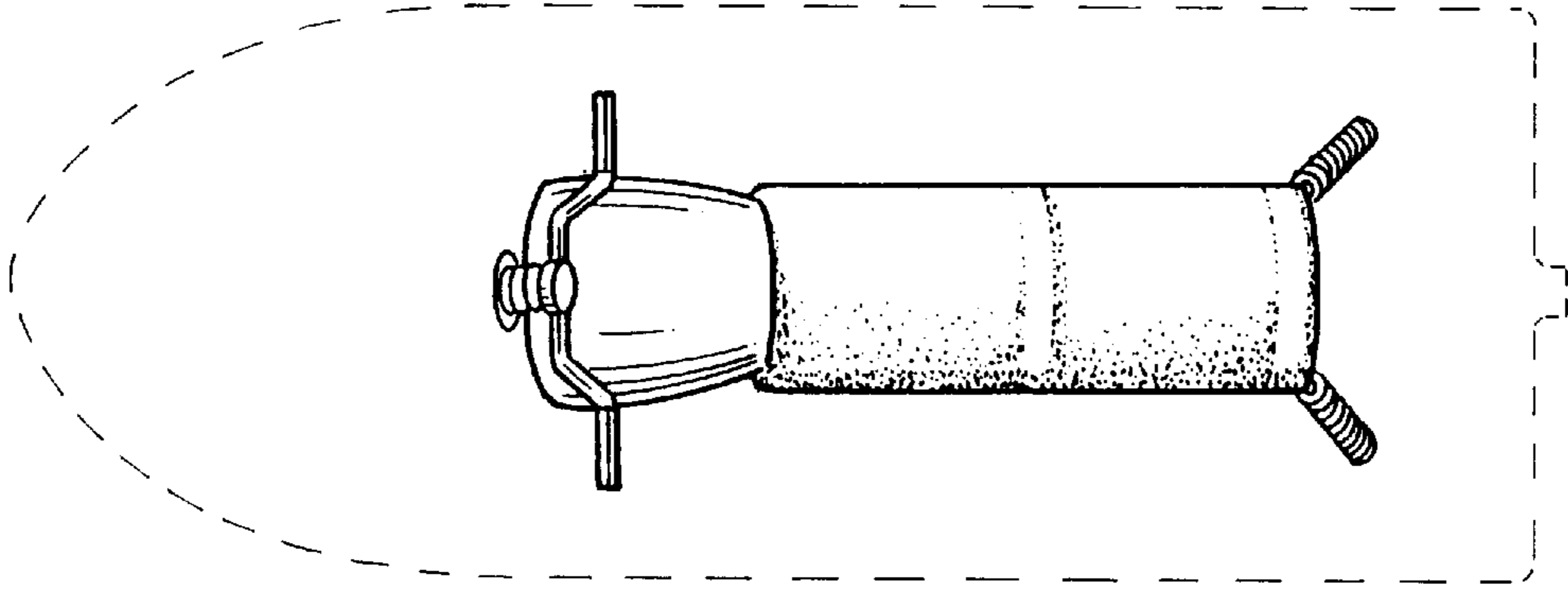

FIG. 12

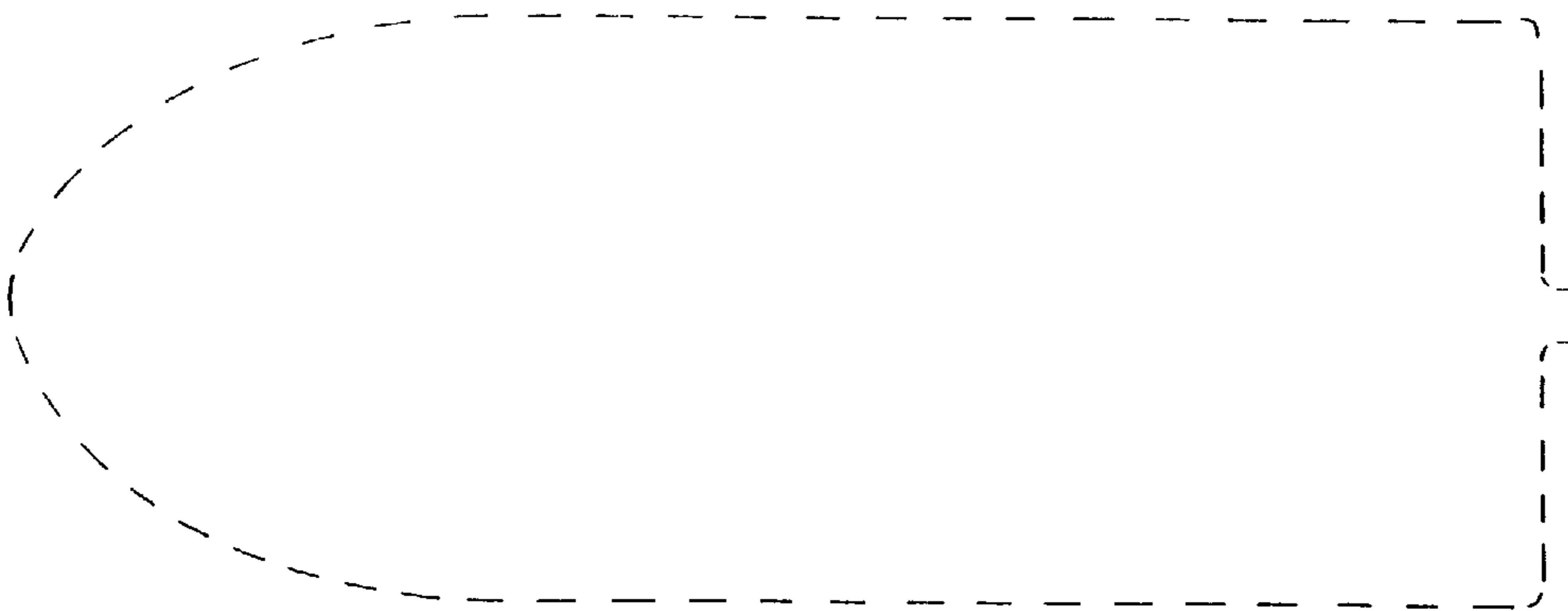

FIG. 13

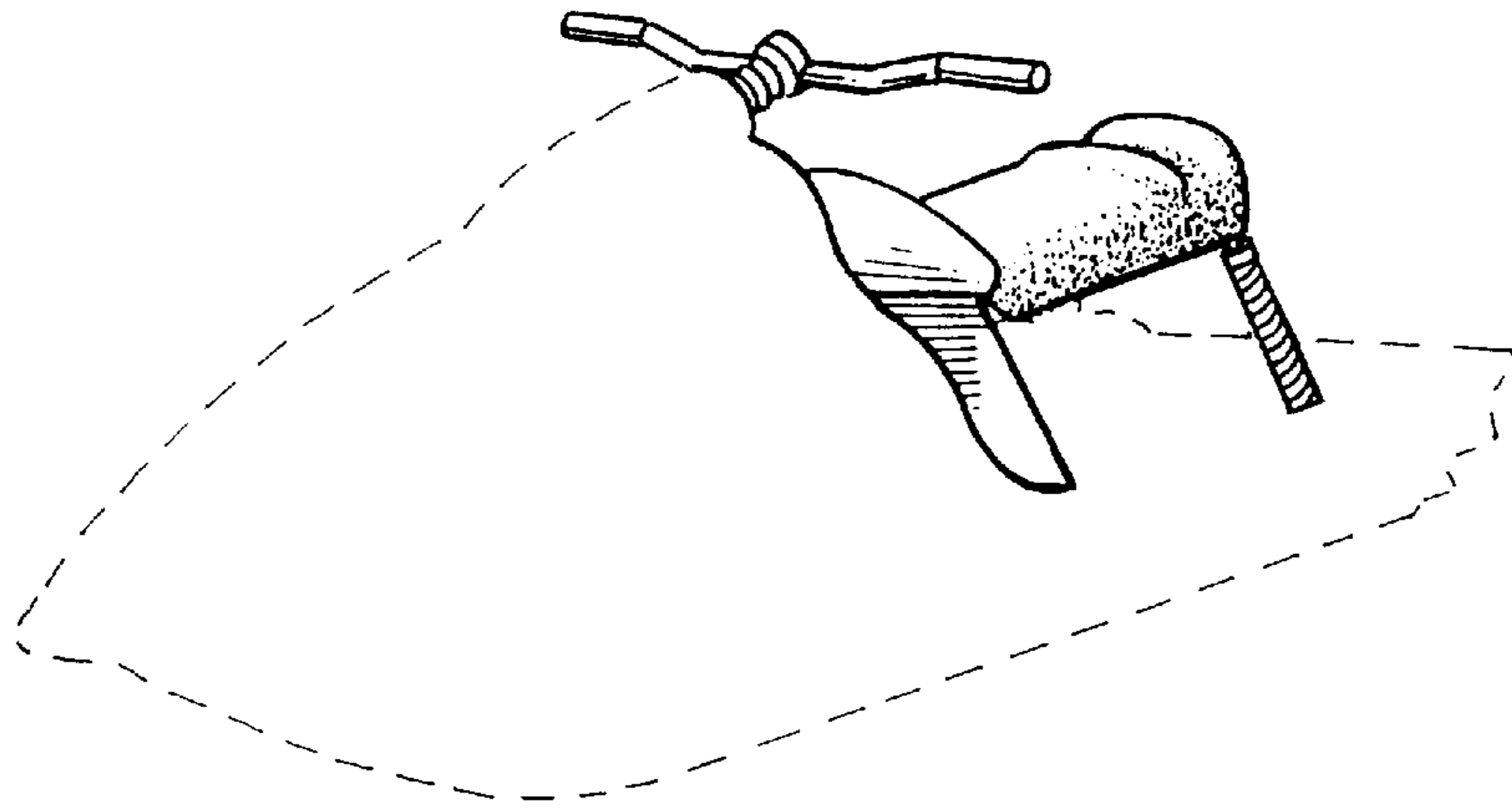

FIG. 14

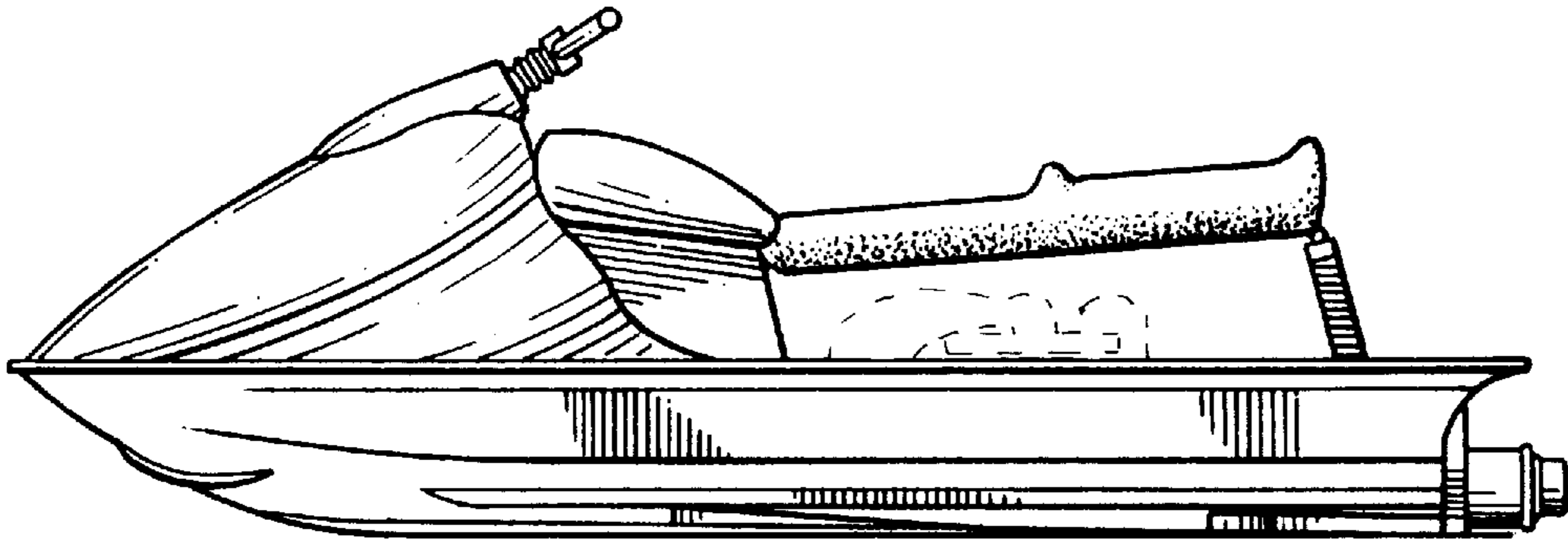

FIG. 15

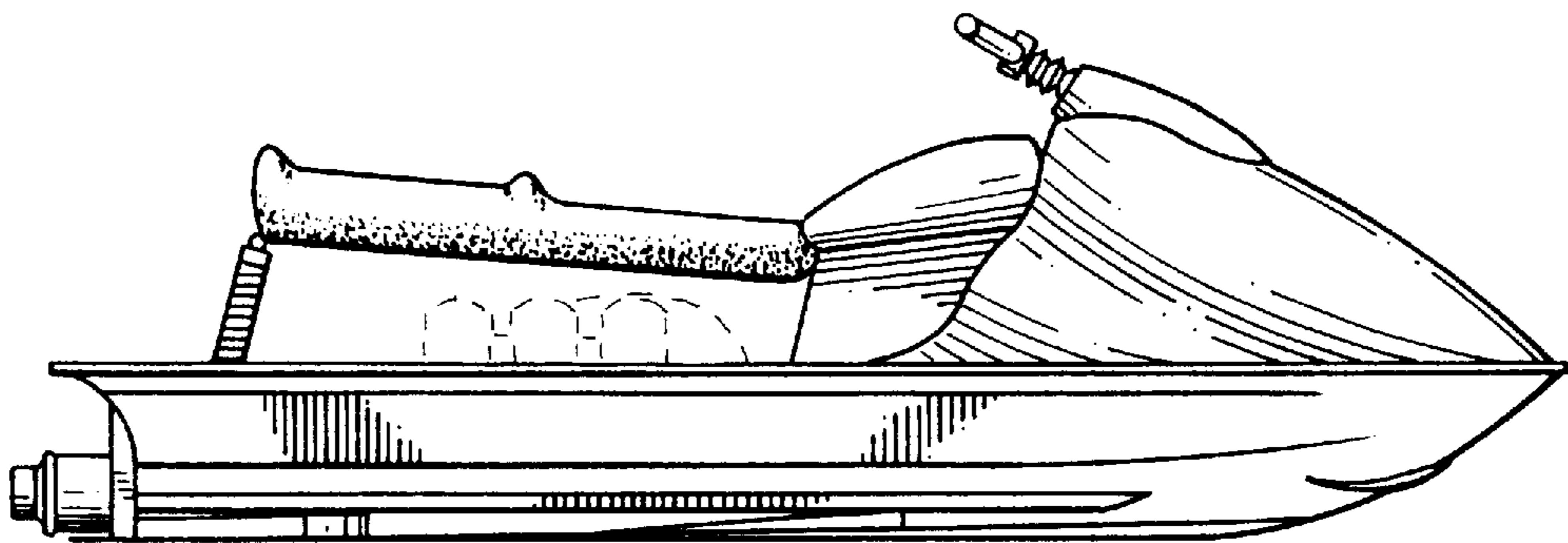

FIG. 16

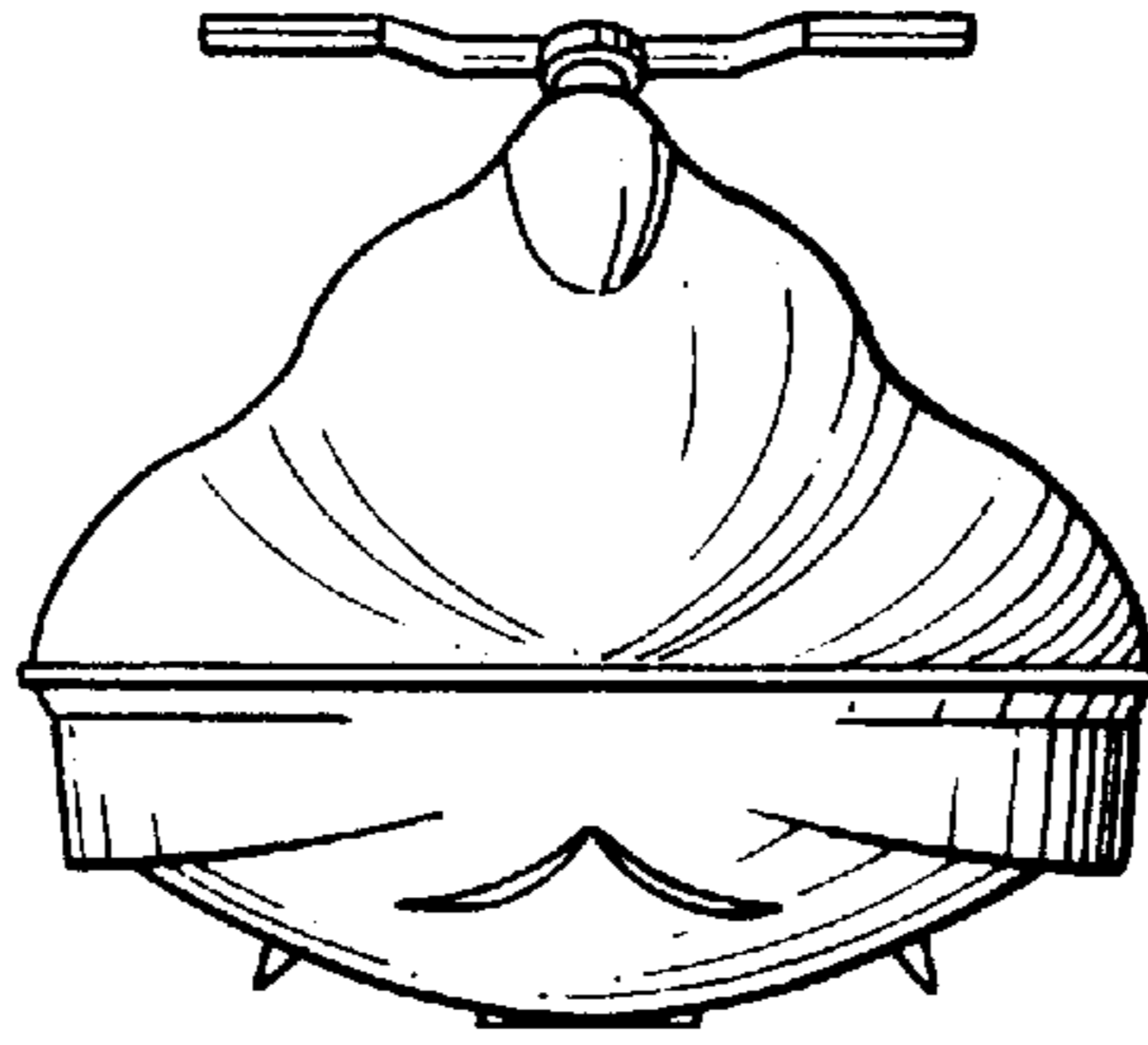

FIG. 17

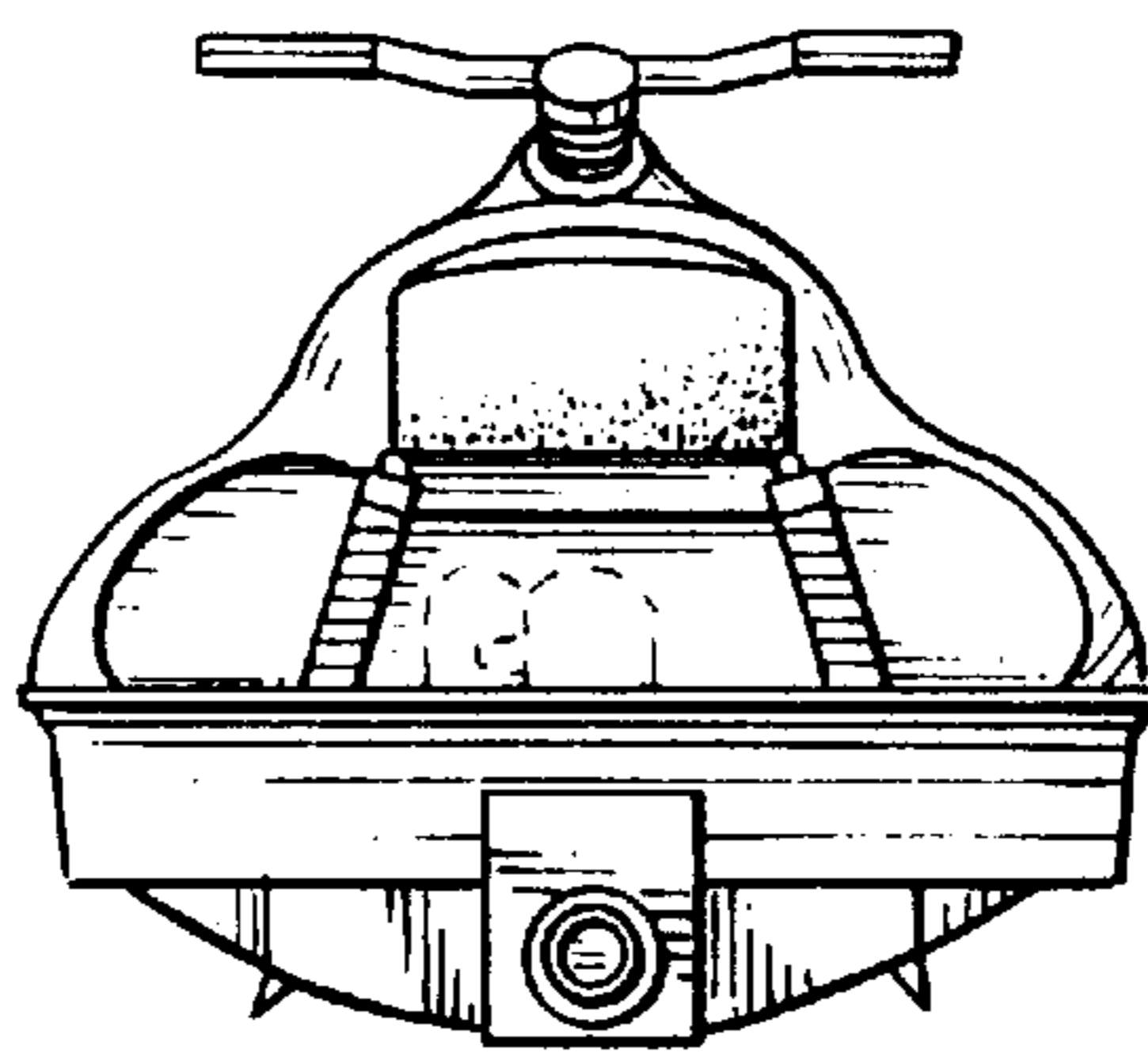

FIG. 18

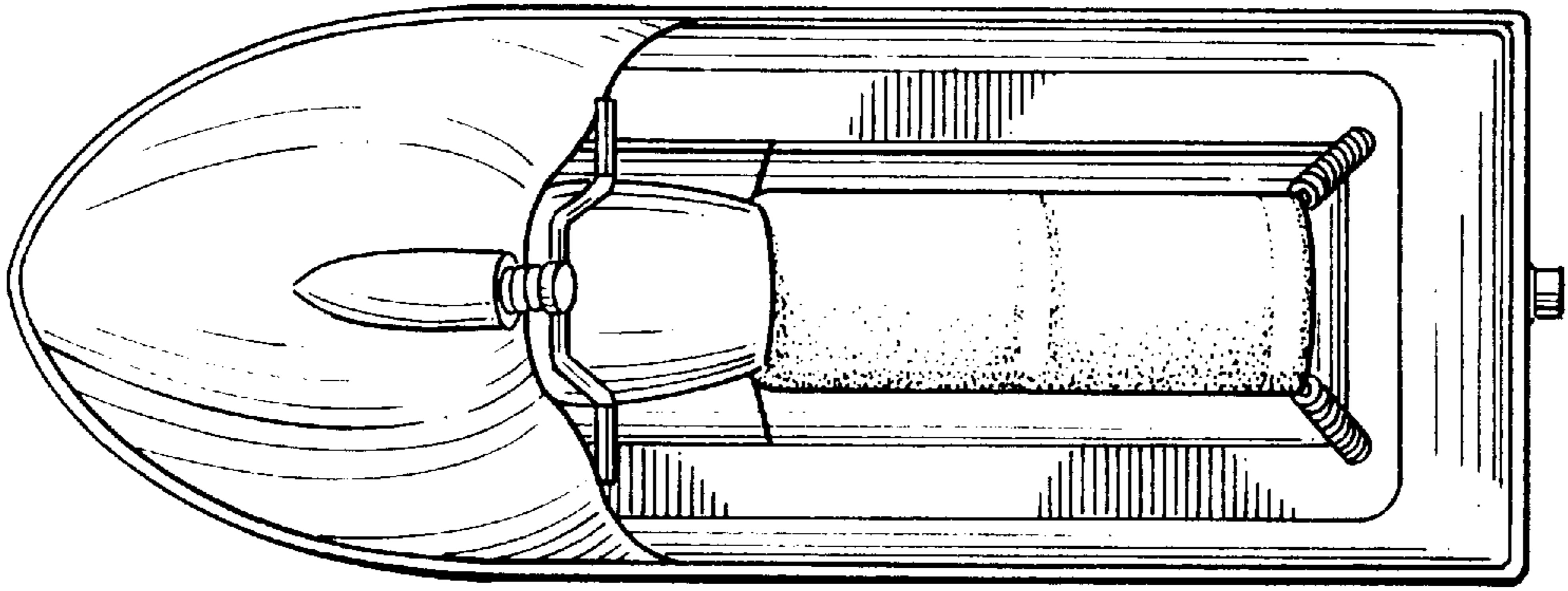

FIG. 19

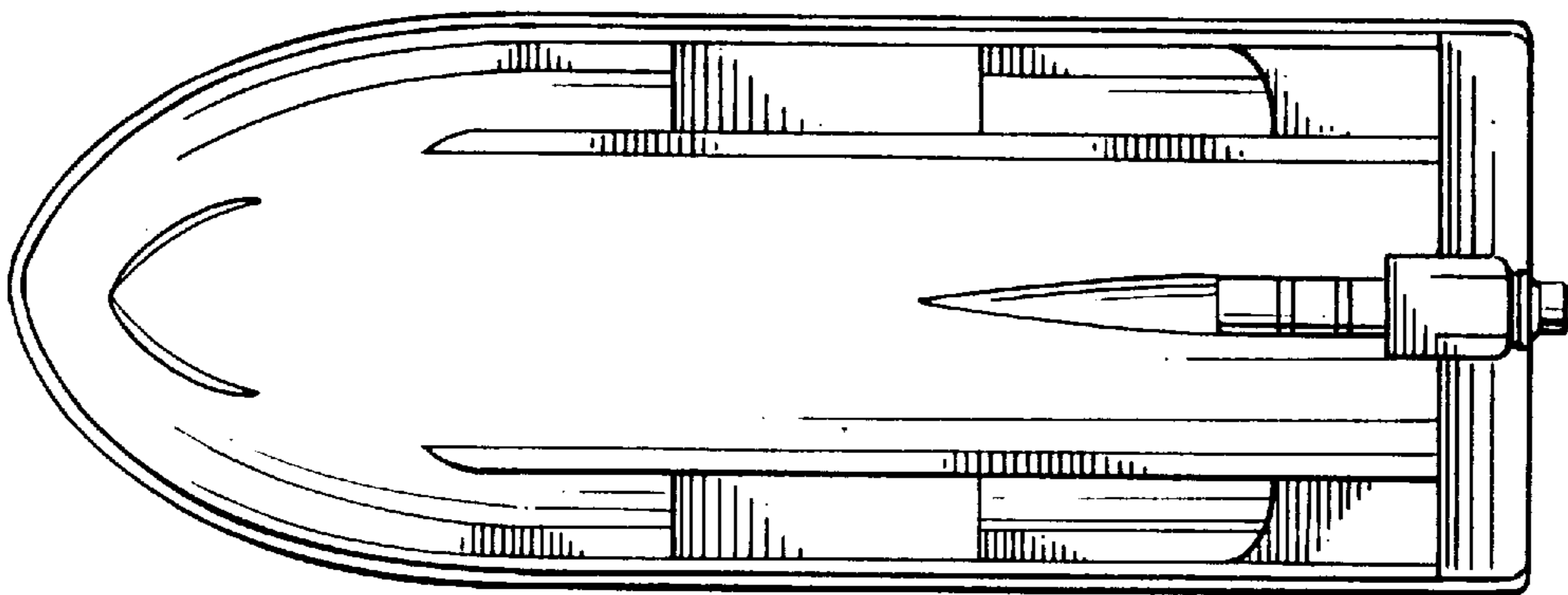

FIG. 20

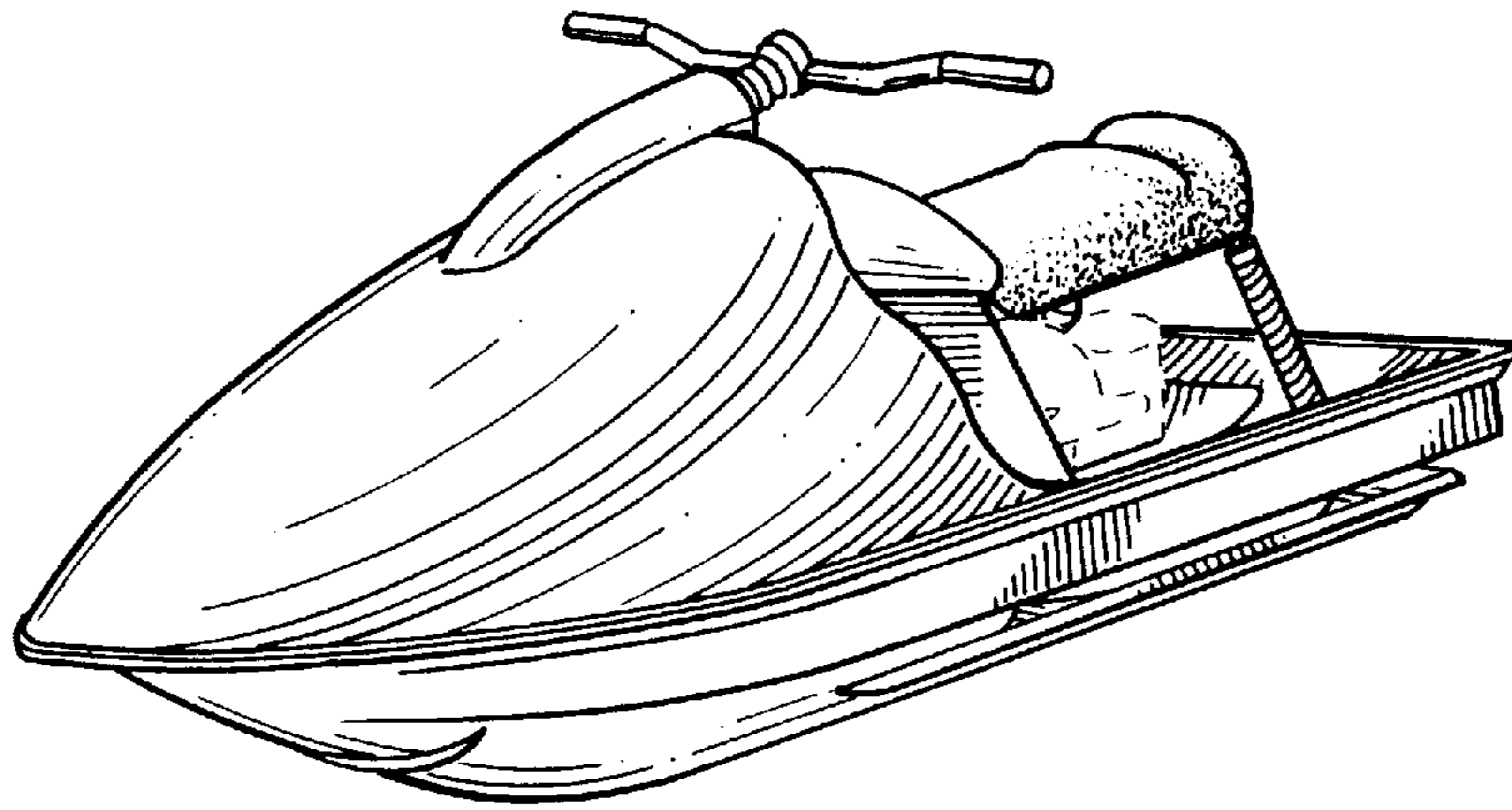

FIG. 21