



US00D401211S

United States Patent [19] Simpson

[11] **Patent Number: Des. 401,211**

[45] **Date of Patent: **Nov. 17, 1998**

[54] **JACK BRACKET**

Primary Examiner—Holly Baynham

[76] Inventor: **Patrick F. Simpson**, 266 W. Post St.,
Bloomfield, Ind. 47424

[57] **CLAIM**

The ornamental design for a jack bracket, as shown and described.

[**] Term: **14 Years**

DESCRIPTION

[21] Appl. No.: **59,161**

FIG. 1 is an exploded, environmental perspective view of the jack bracket;

[22] Filed: **Sep. 4, 1996**

FIG. 2 is an environmental perspective view of the jack bracket assembled;

[51] **LOC (6) Cl.** **12-06**

[52] **U.S. Cl.** **D12/223; D8/349**

FIG. 3 is an enlarged top plan view;

[58] **Field of Search** D8/354, 349; D12/223;
248/300, 200, 201, 229; 296/26, 36, 57.1,
60

FIG. 4 is a side elevation of the jack bracket. The opposite side elevation is identical;

FIG. 5 is a front elevation;

[56] **References Cited**

U.S. PATENT DOCUMENTS

D. 265,171	6/1982	Zukaitis	D8/356 X
D. 269,760	7/1983	Geney	D8/394 X
D. 337,934	8/1993	Young	D8/356
D. 370,453	6/1996	Shortman et al.	D12/223
3,874,624	4/1975	Gianessi	248/200

FIG. 6 is a rear elevation; and,

FIG. 7 is a perspective view.

The broken line showing of a Jeep in FIGS. 1 and 2 and the structure in FIGS. 3–5 is for illustrative purposes only and forms no part of the claimed design.

1 Claim, 4 Drawing Sheets

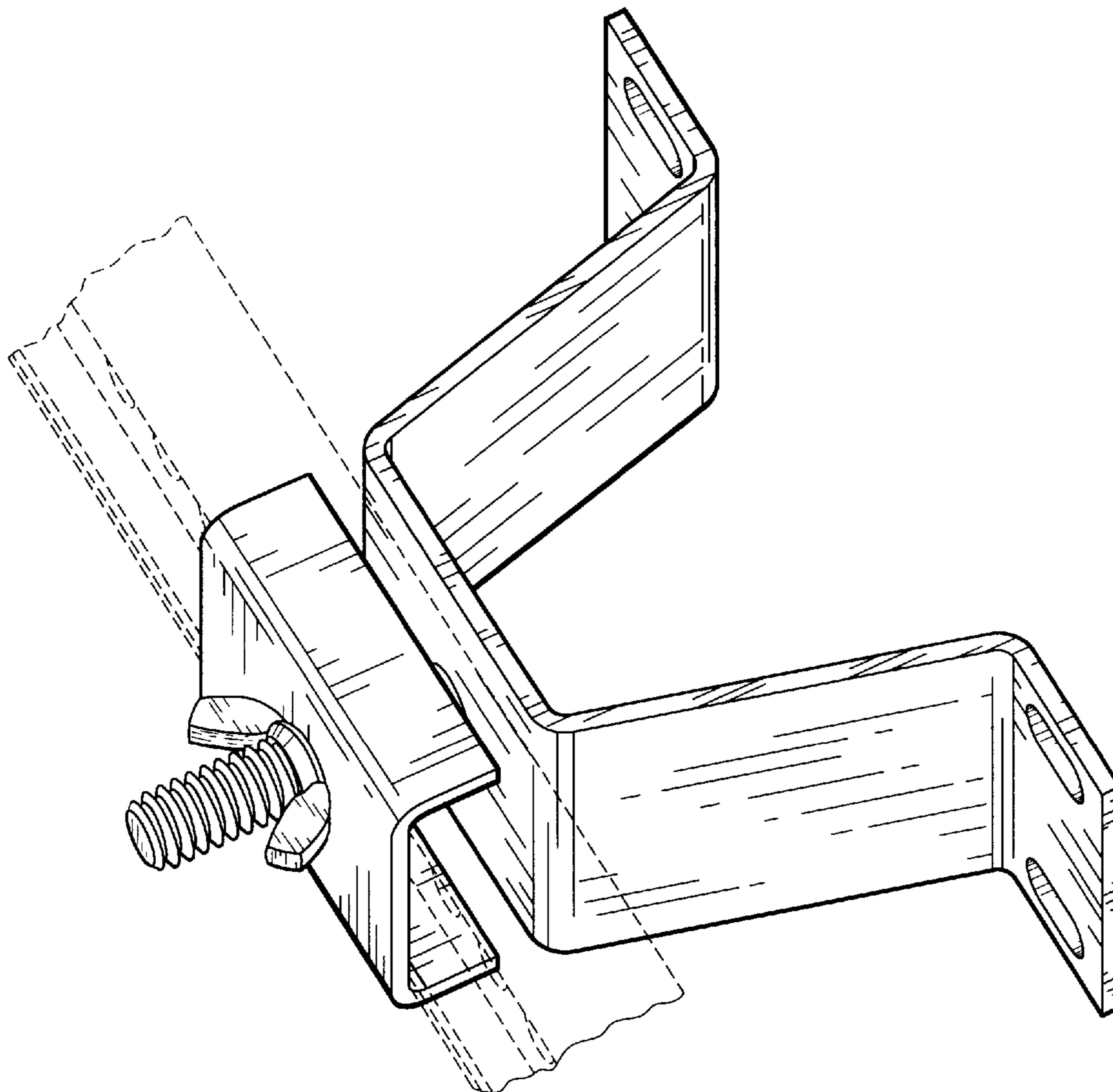

Fig. 1

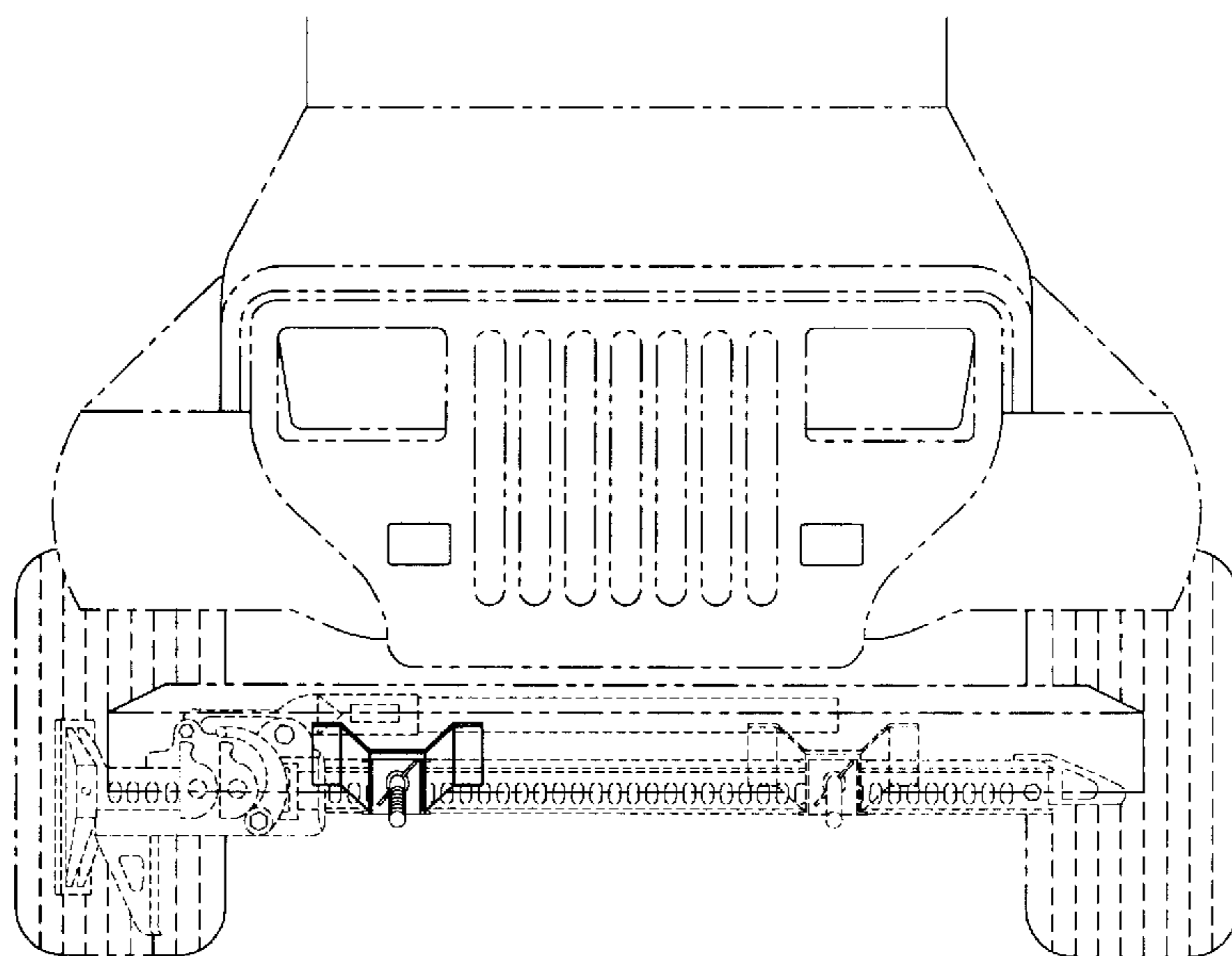
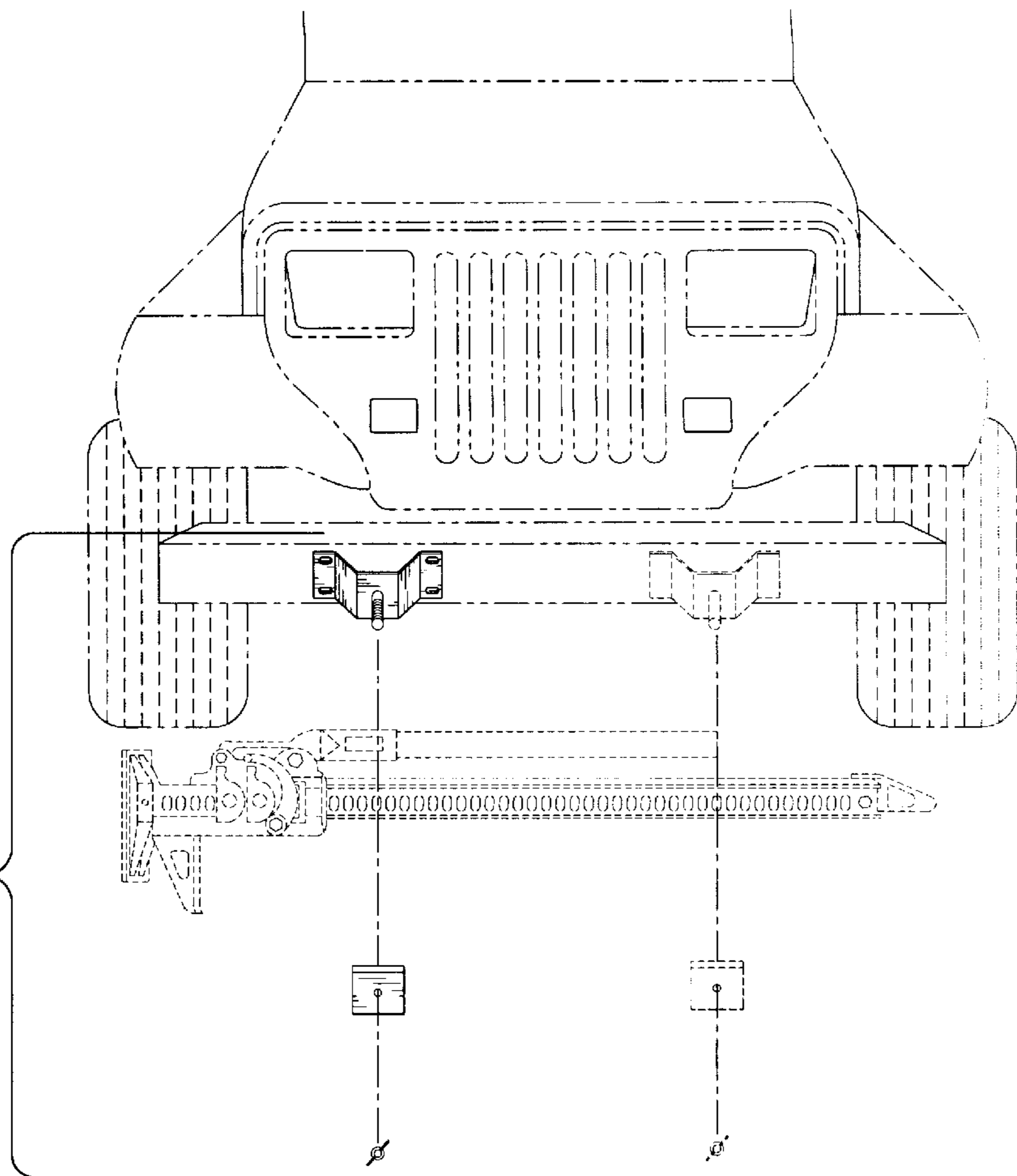

Fig. 2

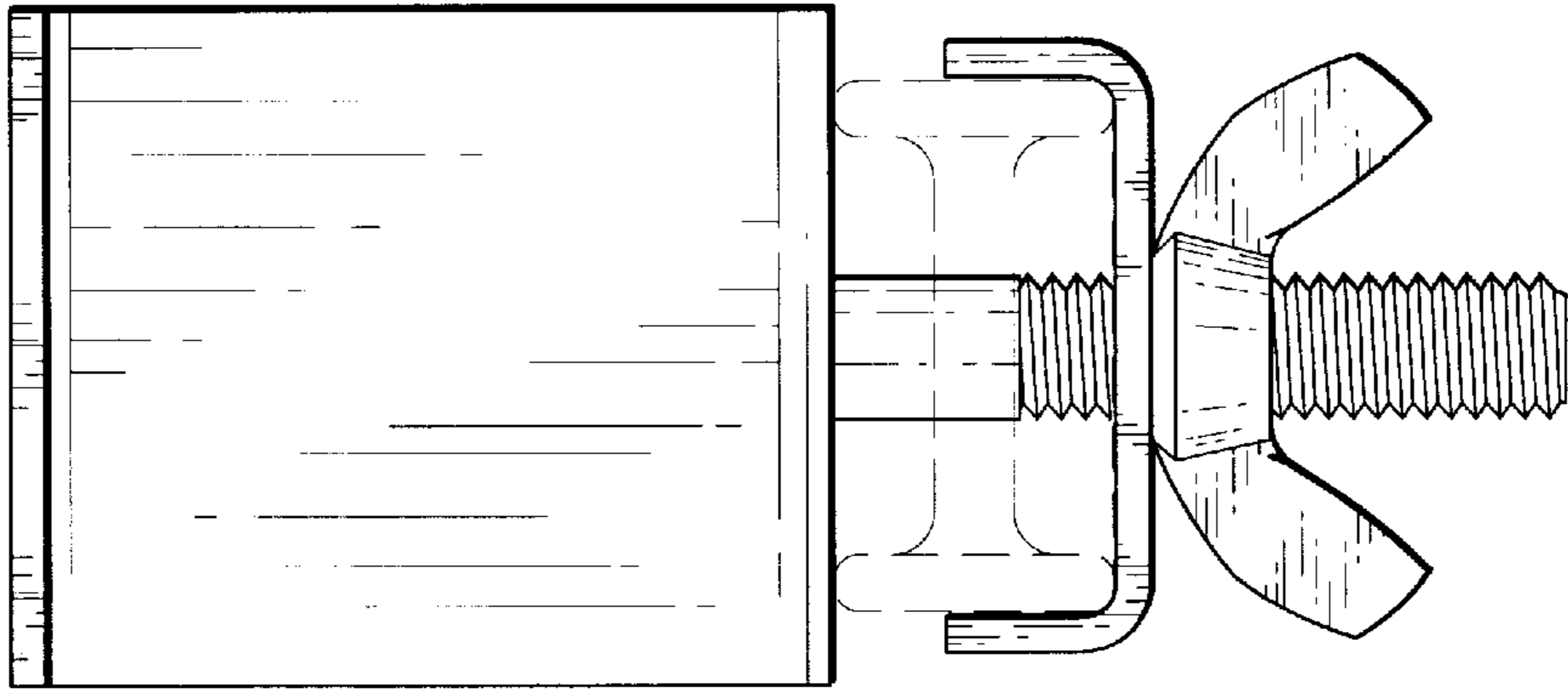

Fig. 4

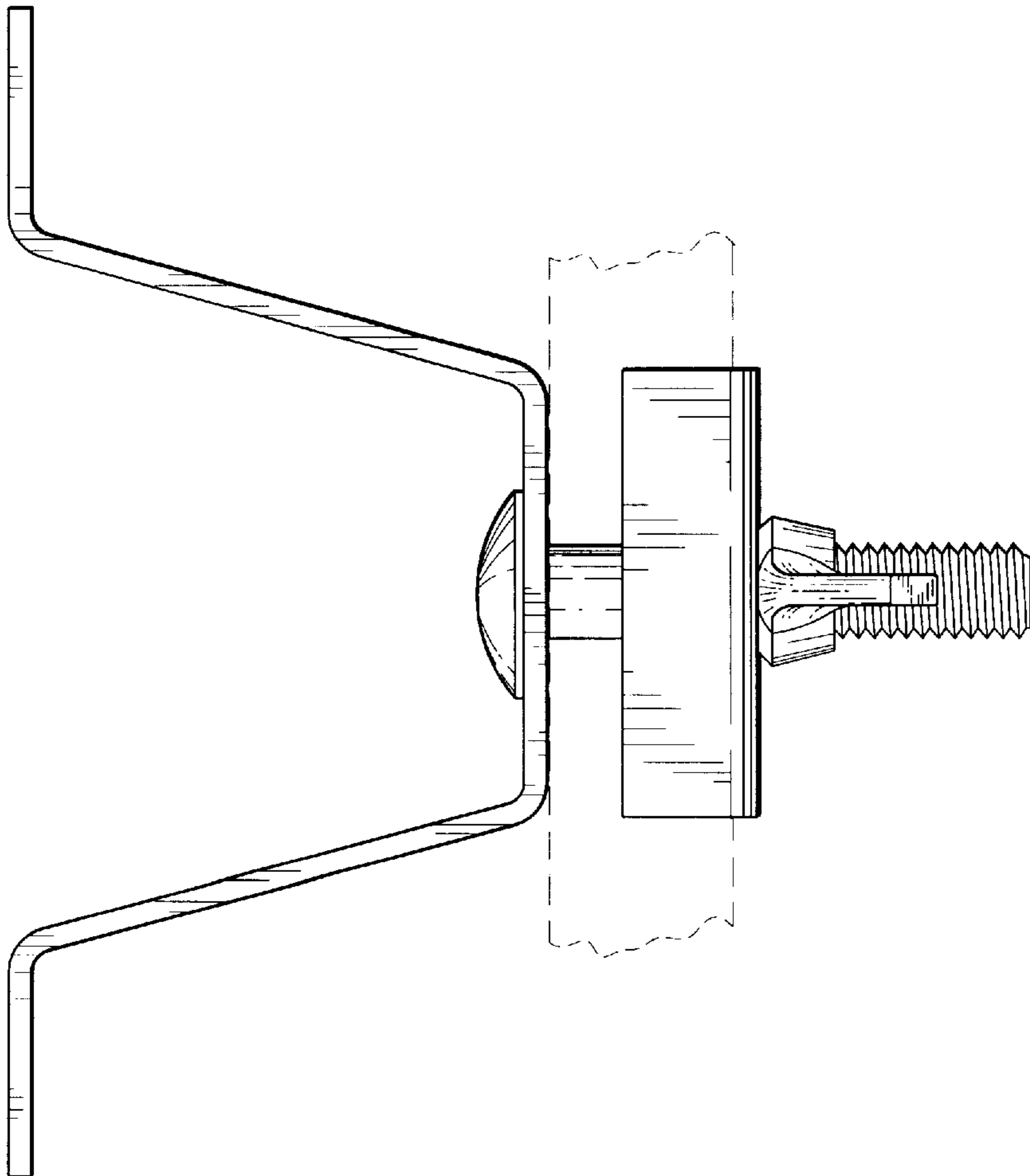

Fig. 3

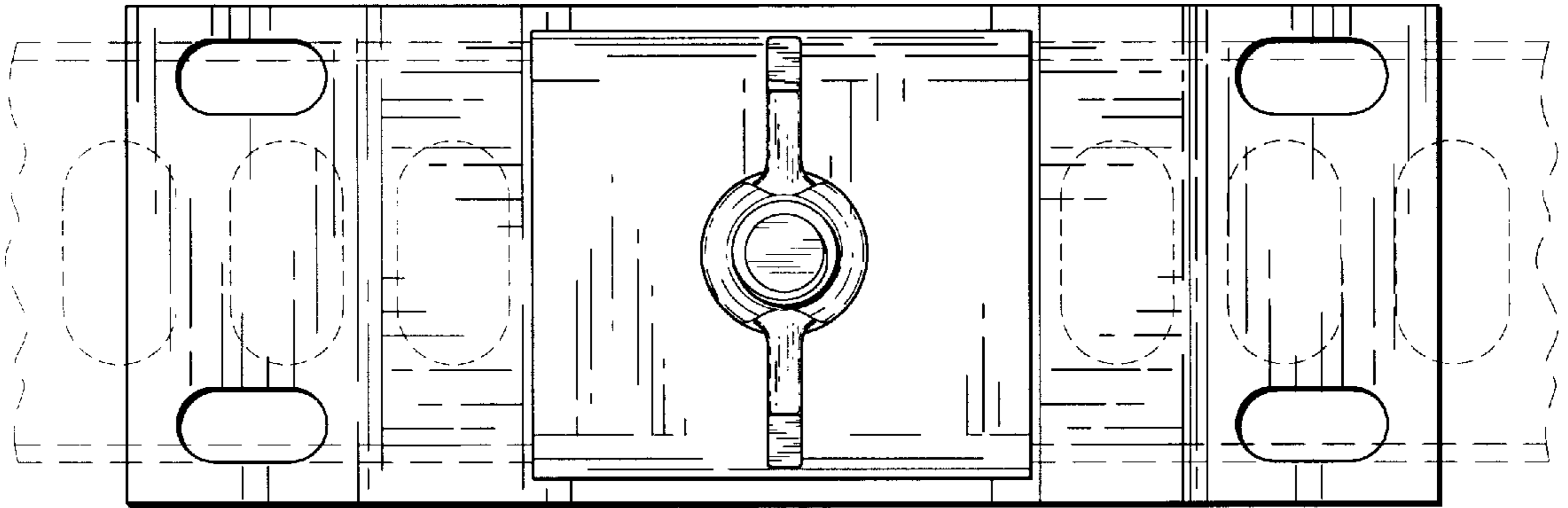

Fig. 5

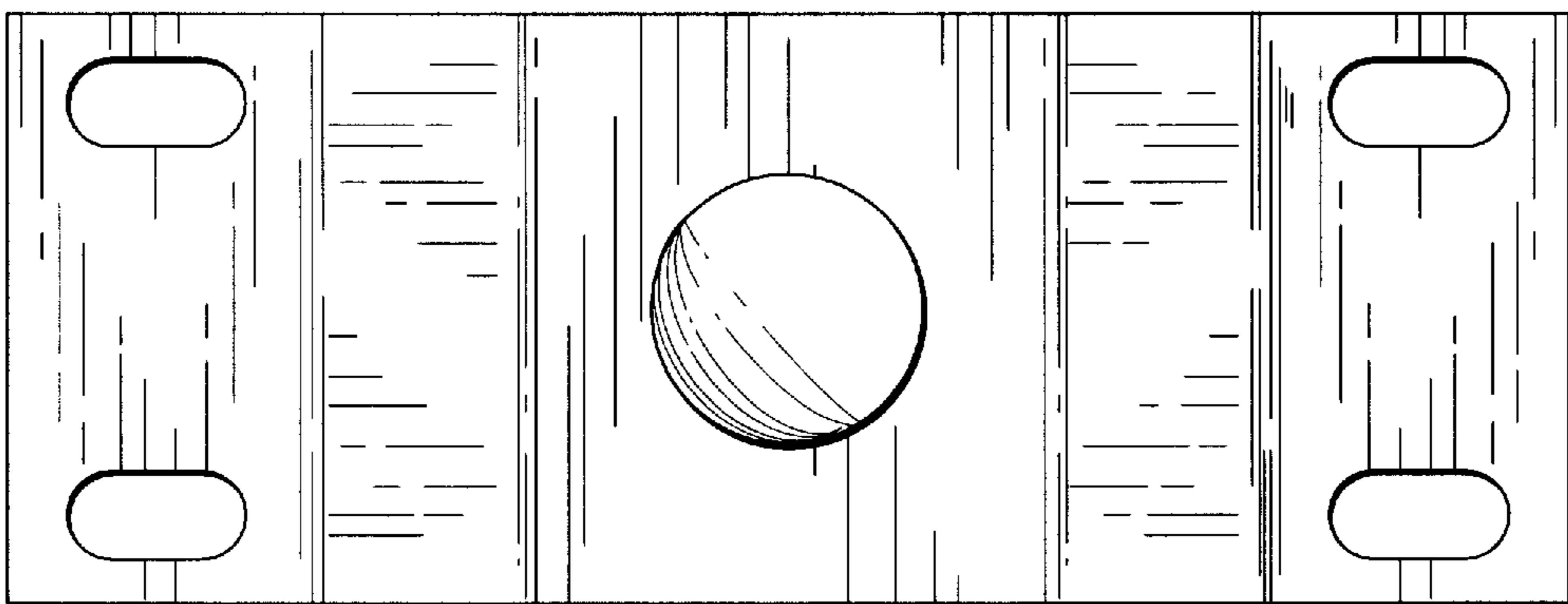

Fig. 6

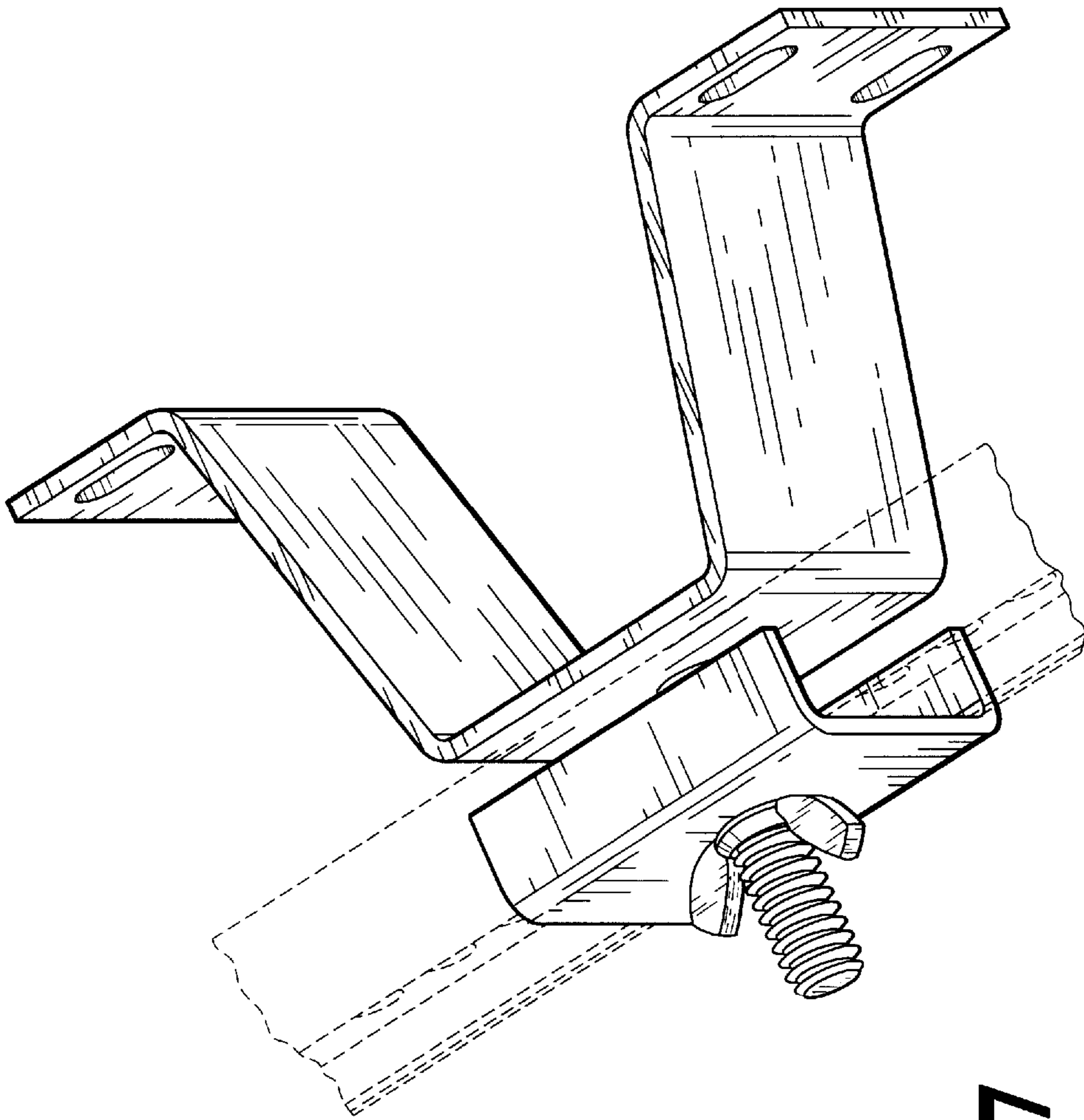

Fig. 7