



US00D401205S

United States Patent [19]
Fischer

[11] **Patent Number: Des. 401,205**
[45] **Date of Patent: **Nov. 17, 1998**

[54] **FRONT FACE OF A VEHICLE WHEEL**

D. 370,883 6/1996 Bhambra D12/209

[75] Inventor: **Corrado Fischer**, Venice, Italy

OTHER PUBLICATIONS

[73] Assignee: **Mercedes-Benz AG**, Stuttgart, Germany

Motor Trend, p. 98, See "Rota Harpoon", Dec. 1995.
Road & Track, p. 107, See "Mille Miglia", Dec. 1995.
Custom Wheel & Tire Style Guide, See "Antares Chrome",
1993.

[**] Term: **14 Years**

[21] Appl. No.: **58,550**

Primary Examiner—James Gandy
Assistant Examiner—Stacia Sinuik
Attorney, Agent, or Firm—Evenson, McKeown, Edwards &
Lenahan, P.L.L.C.

[22] Filed: **Aug. 19, 1996**

[30] **Foreign Application Priority Data**

Feb. 19, 1996 [DE] Germany M 96 01 421.0

[57] **CLAIM**

[51] **LOC (6) Cl.** **12-16**

The ornamental design for a front face of a vehicle wheel,
as shown and described.

[52] **U.S. Cl.** **D12/209**

[58] **Field of Search** D12/204-213;
301/64.1, 65, 37.1

DESCRIPTION

[56] **References Cited**

U.S. PATENT DOCUMENTS

D. 204,256	4/1966	Rader	D12/207
D. 244,272	5/1977	Raudman, Jr. et al.	D12/205
D. 249,787	10/1978	Tanaka	D12/205
D. 276,993	1/1985	Hedlund	D12/211
D. 361,976	9/1995	Echazabal et al.	D12/211

FIG. 1 is a front view of a front face of a vehicle wheel
according to my novel design; and,
FIG. 2 is a perspective view of a front face of a vehicle wheel
according to my novel design.

The broken lines are for illustrative purposes only and form
no part of the claimed design.

1 Claim, 1 Drawing Sheet

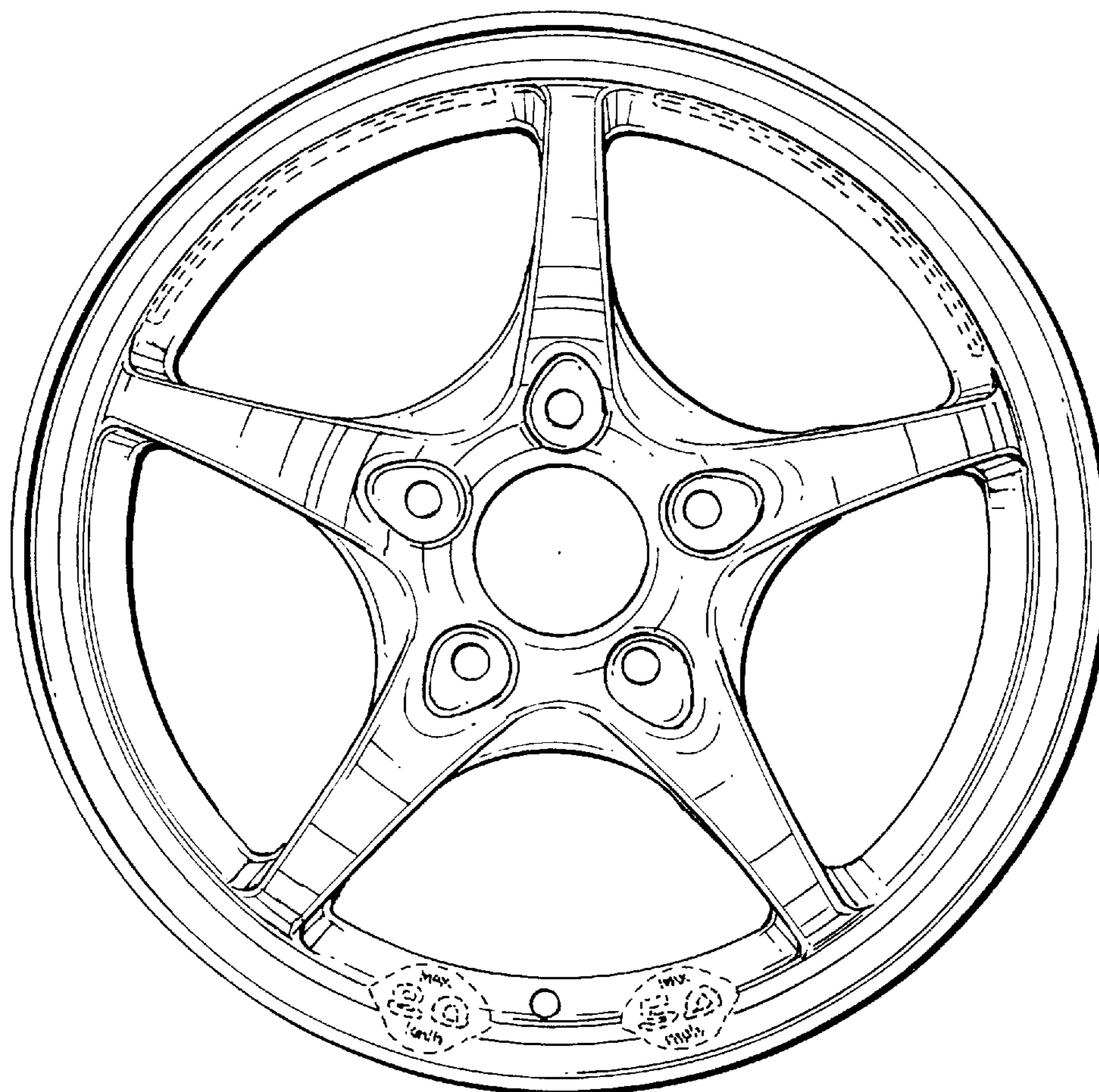

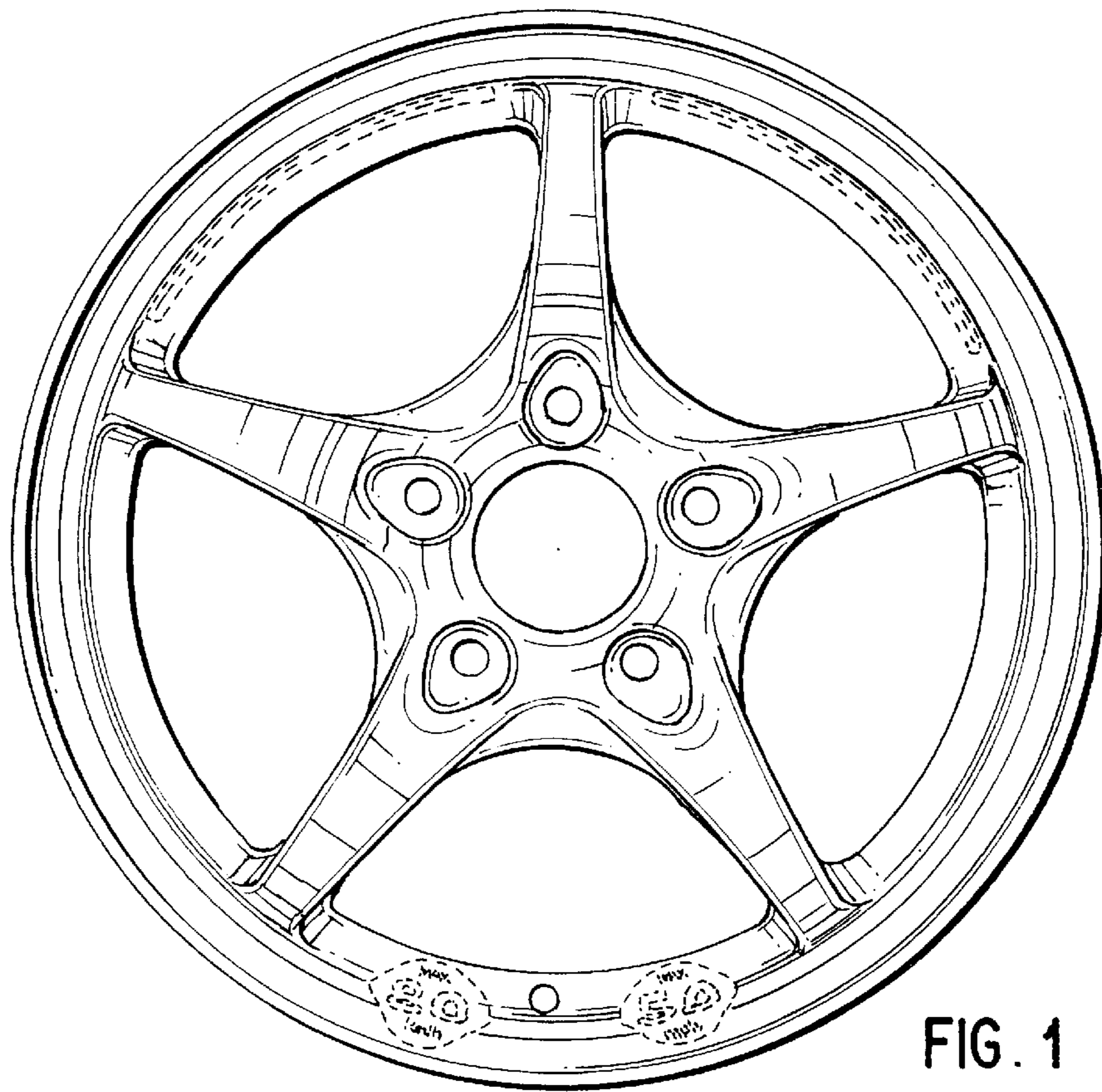

FIG. 1

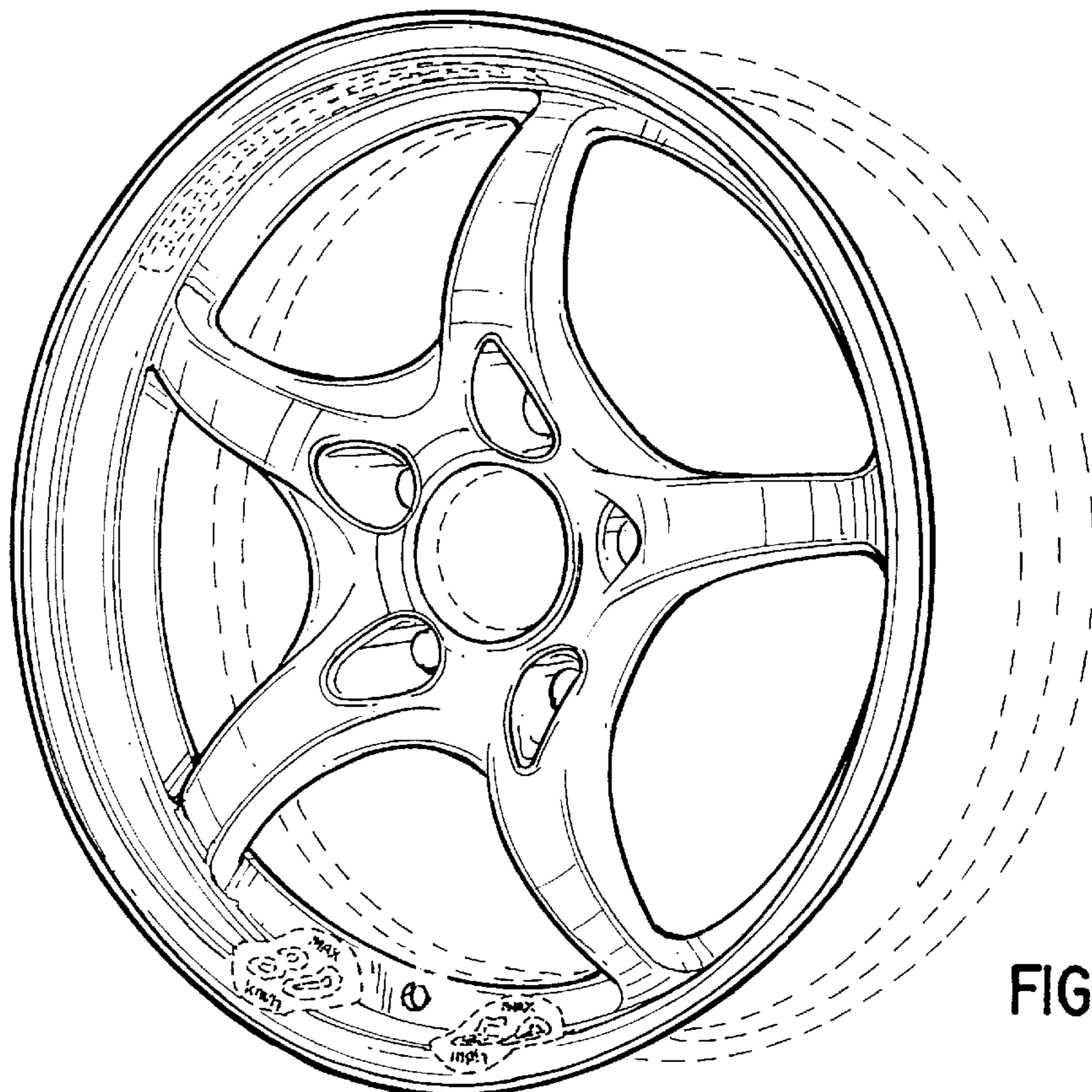

FIG. 2