



US00D400893S

United States Patent [19]
Peterson

[11] **Patent Number: Des. 400,893**

[45] **Date of Patent: **Nov. 10, 1998**

[54] **UNIVERSAL CRIMPING TOOL**

[75] Inventor: **Larry Peterson**, Chicago, Ill.

[73] Assignee: **Hosecomatic**, Chicago, Ill.

[**] Term: **14 Years**

[21] Appl. No.: **77,120**

[22] Filed: **Sep. 22, 1997**

[51] **LOC (6) Cl.** **15-09**

[52] **U.S. Cl.** **D15/123**

[58] **Field of Search** D15/138, 123;
219/69.15, 69.2; 29/517, 243.5; 72/416,
454, 404, 472, 384, 409.14, 461, 712

[56] **References Cited**

U.S. PATENT DOCUMENTS

5,353,623 10/1994 Bobenhausen 72/416 X
5,692,294 12/1997 Casey 72/409.14 X
5,720,197 2/1998 Grau et al. 72/402

Primary Examiner—Antoine Duval Davis
Attorney, Agent, or Firm—Dick and Harris

[57] **CLAIM**

The ornamental design for a universal crimping tool, as shown.

DESCRIPTION

FIG. 1 is a perspective view of a crimping tool embodying my new design;
FIG. 2 is a front elevational view thereof;
FIG. 3 is a rear elevational view thereof;
FIG. 4 is a top plan view thereof;
FIG. 5 is a bottom plan view thereof;
FIG. 6 is a left side elevational view thereof;
FIG. 7 is a right side elevational view thereof;
FIG. 8 is a front elevational view thereof with clamping mechanism released for reversing configuration of the hole calipers;
FIG. 9 is a front elevational view thereof in open position;
FIG. 10 is a front elevational view thereof in open position, but with the configuration reversed of the hole calipers;
FIG. 11 is a front elevational view thereof with reversed hole caliper configuration; and,
FIG. 12 is another embodiment of the invention.

1 Claim, 3 Drawing Sheets

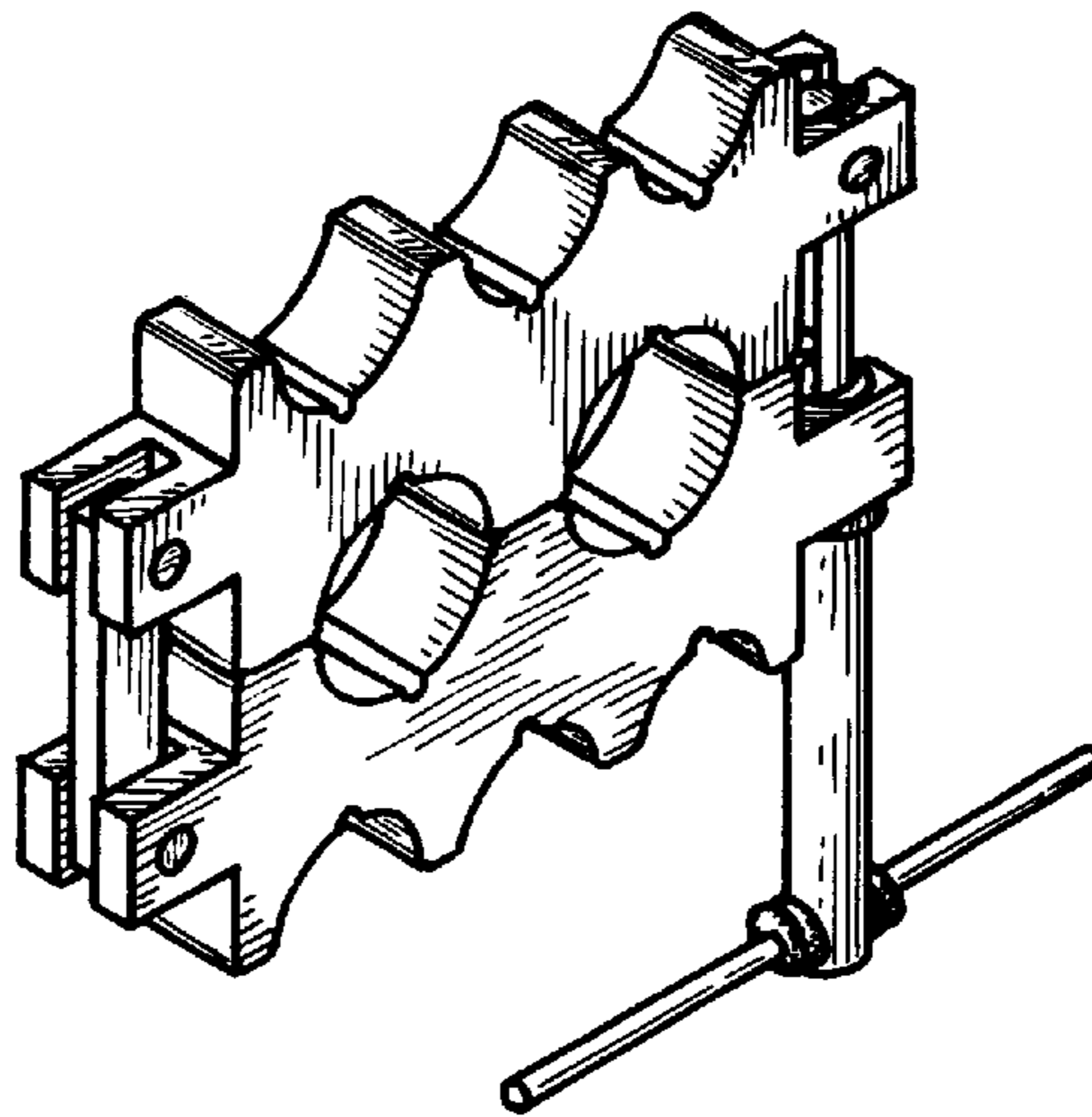

Fig 1

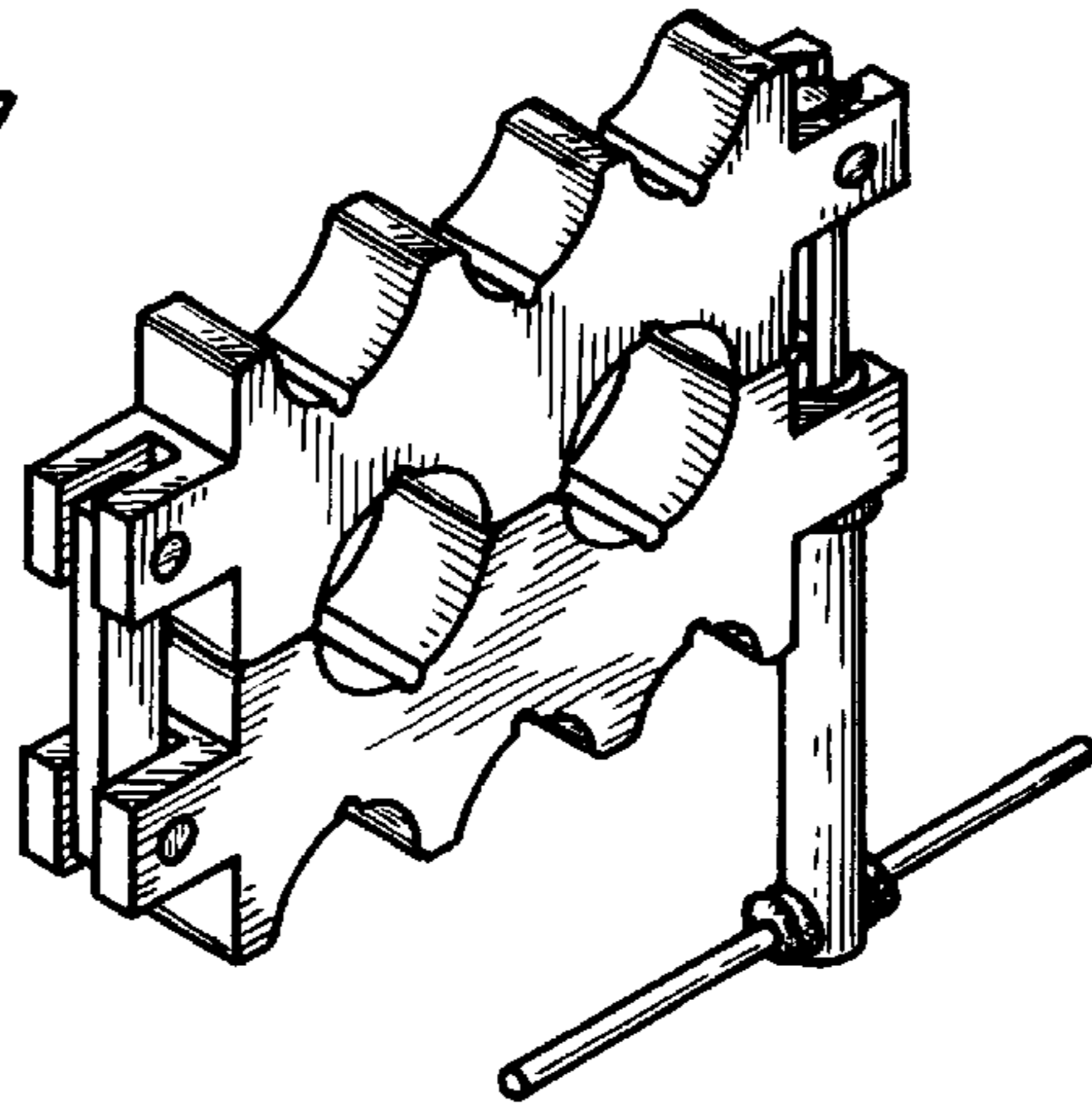

Fig 2

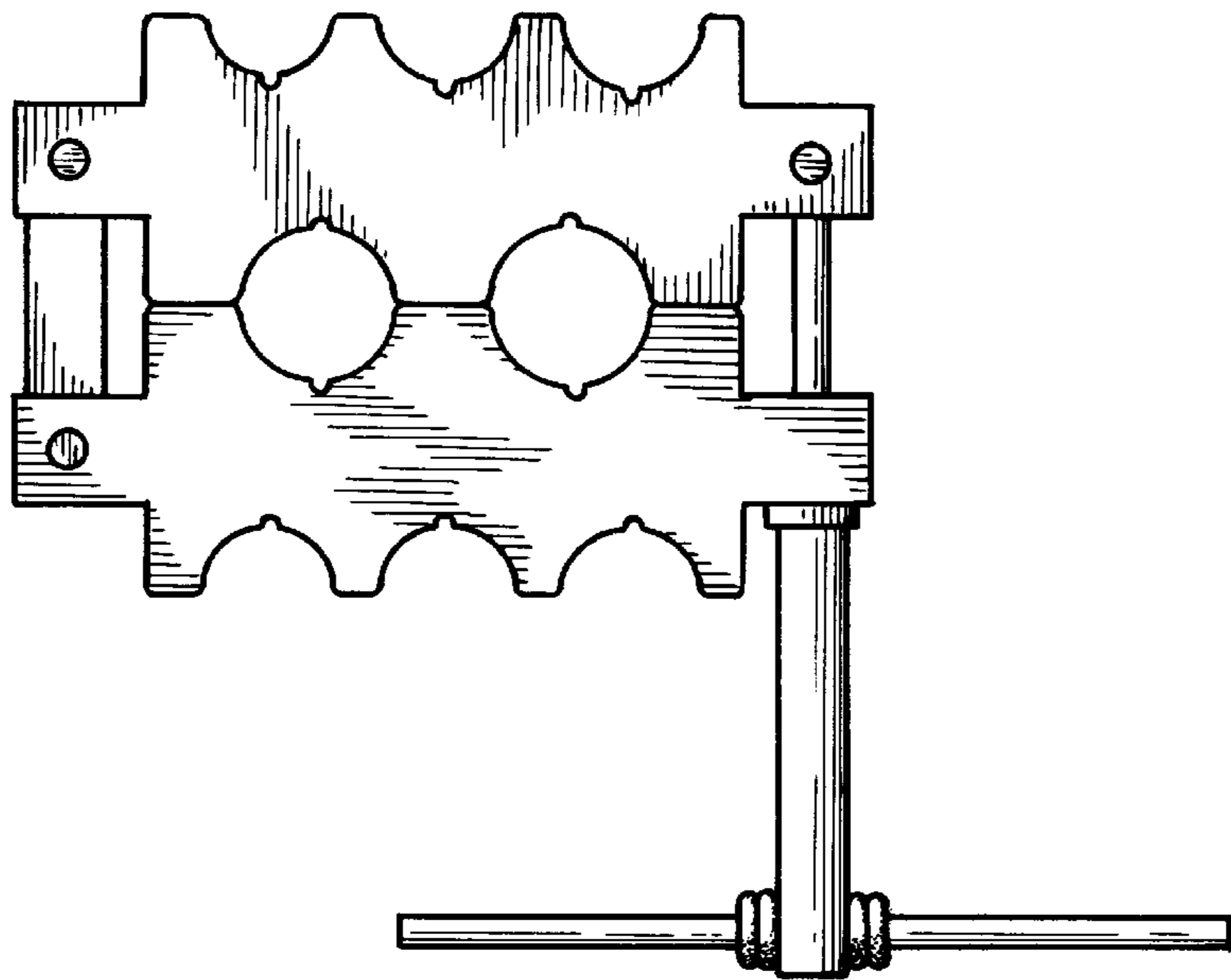

Fig 3

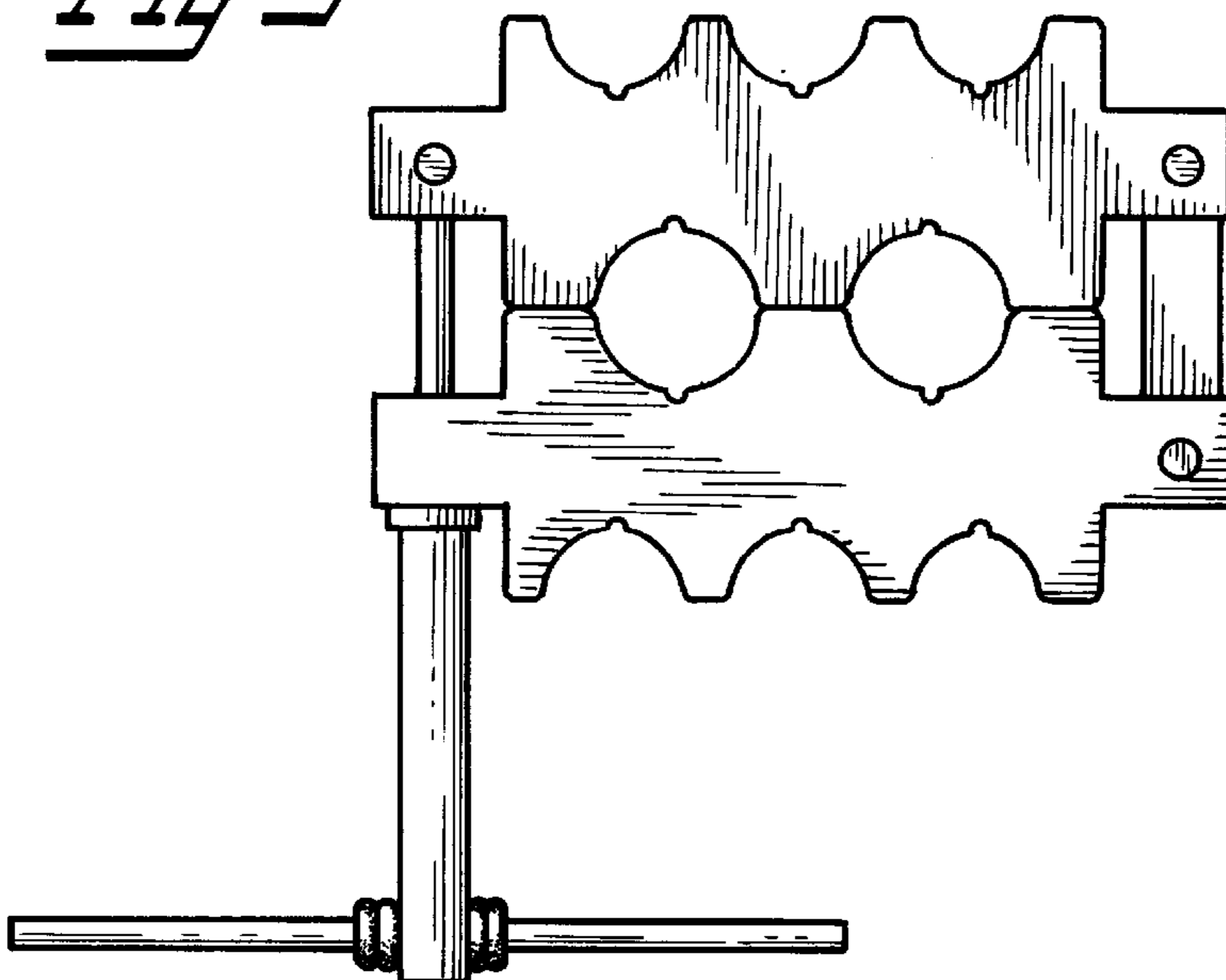

Fig 4



Fig 5



Fig 6



Fig 7



Fig 12

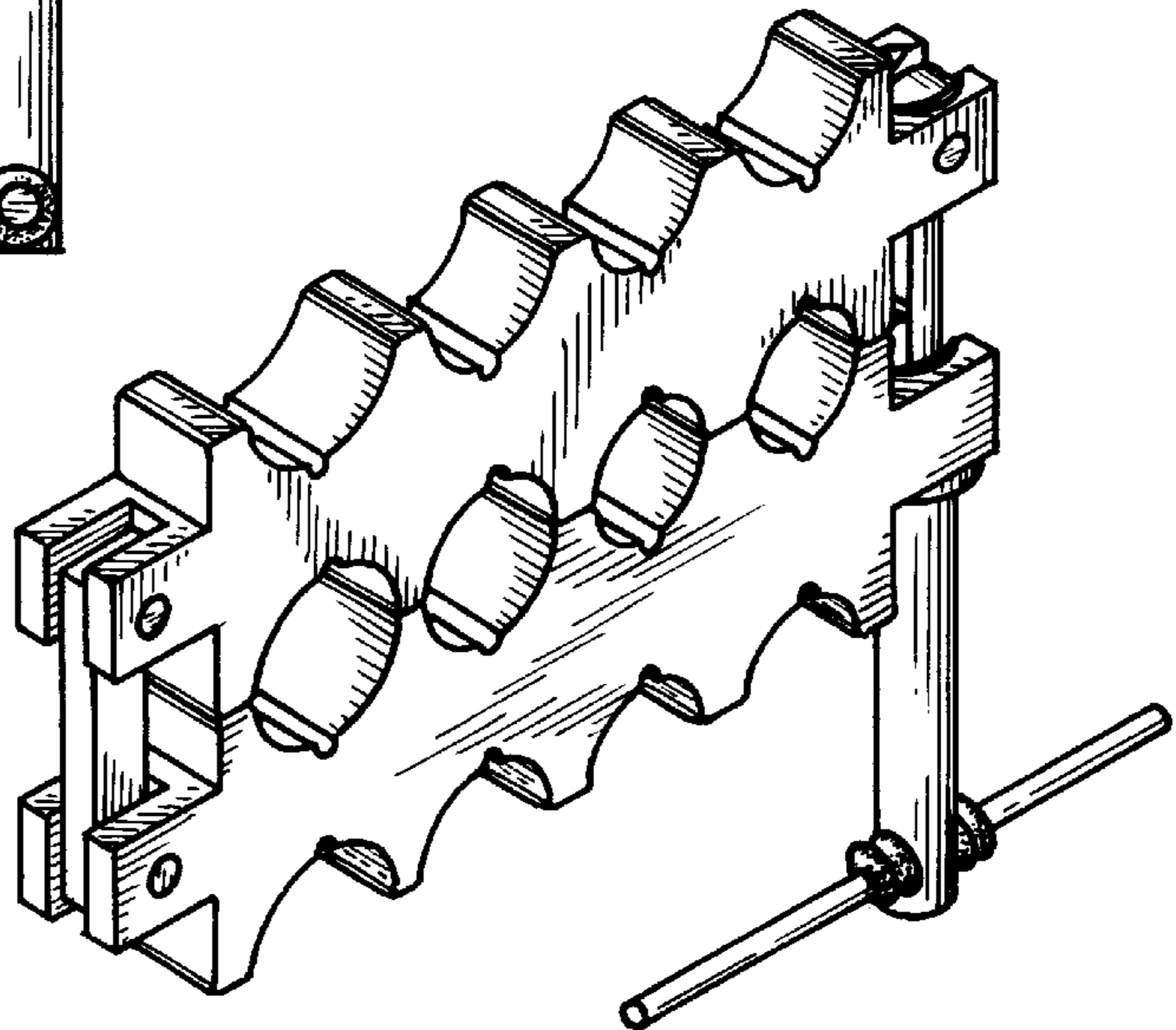

Fig 8

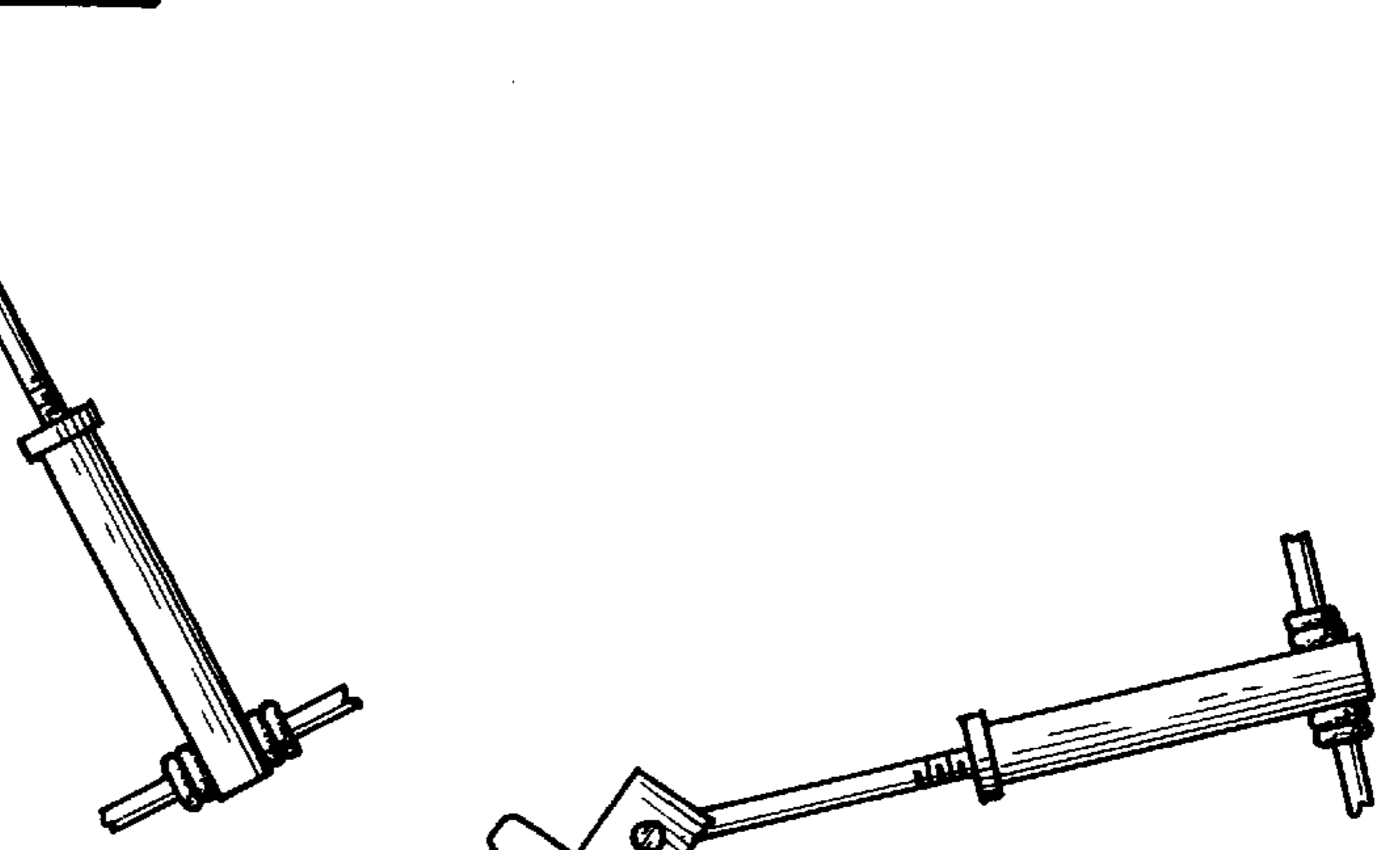
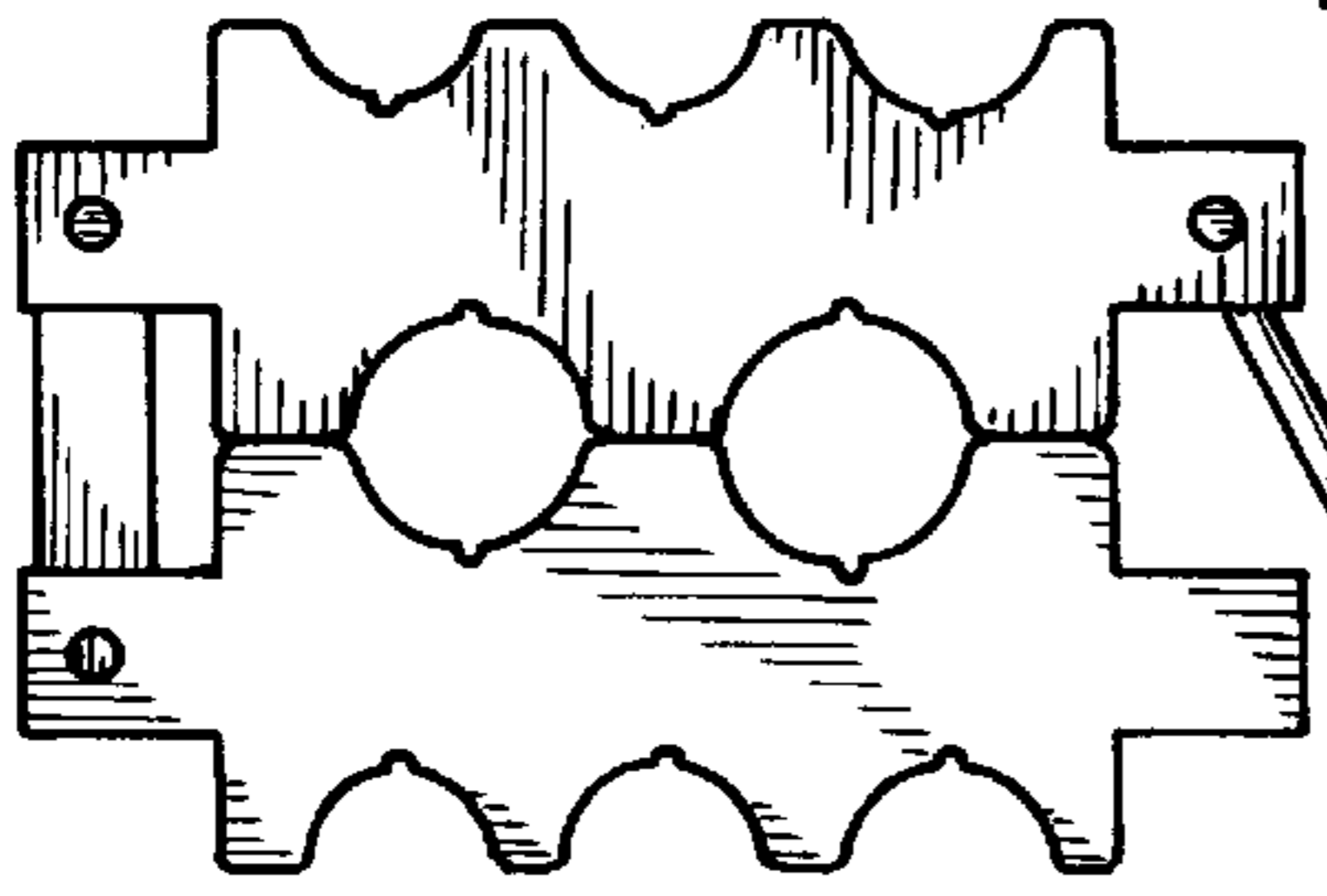

Fig 9

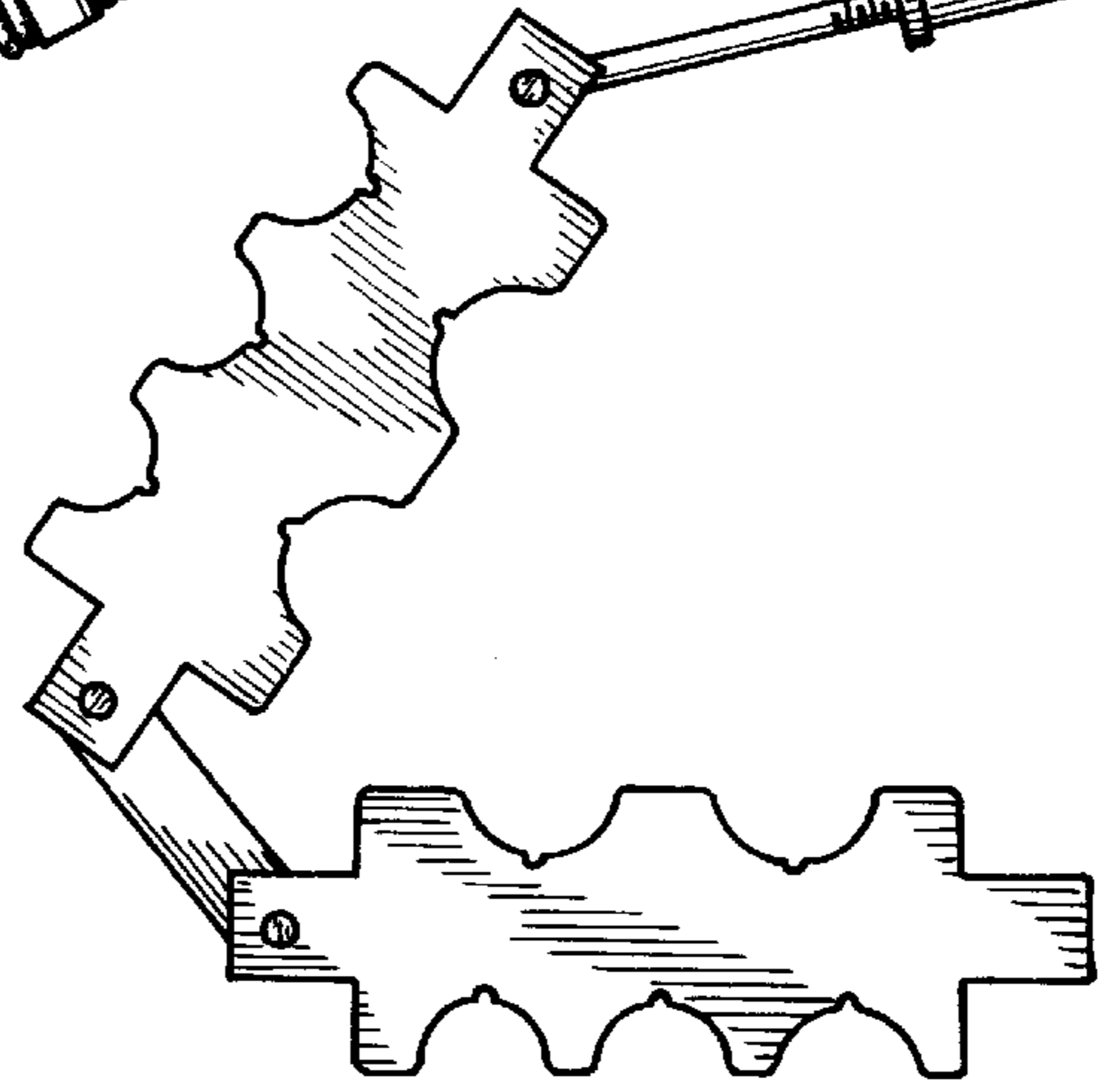

Fig 10

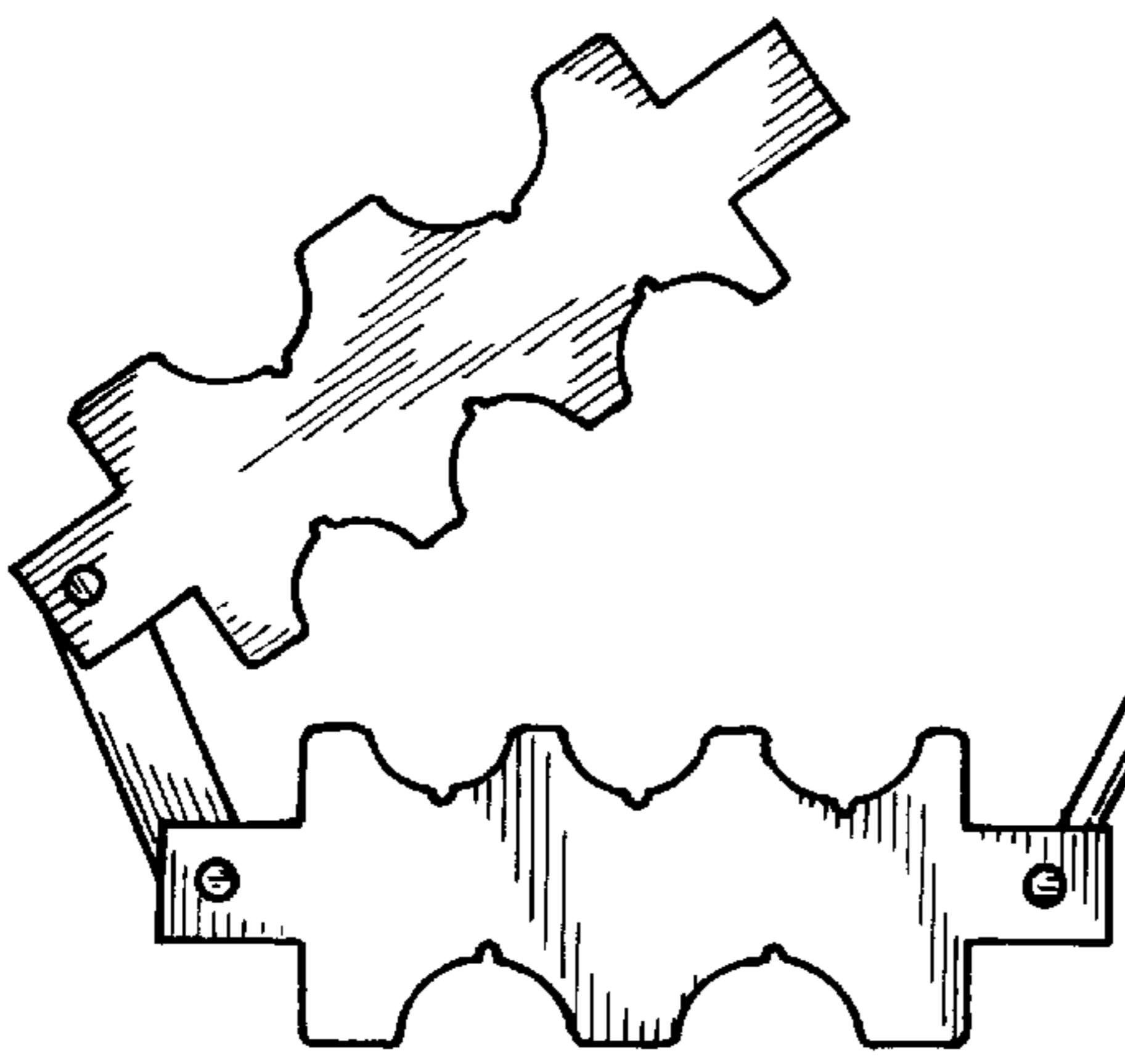

Fig 11

