



US00D400853S

United States Patent [19]
Chen

[11] **Patent Number: Des. 400,853**

[45] **Date of Patent: **Nov. 10, 1998**

[54] **RETRACTABLE AUTOMOTIVE BATTERY
CABLE HOUSING**

D. 352,928 11/1994 Ford D13/120
4,466,581 8/1984 Hill 242/405.3 X
4,904,205 2/1990 Rice 439/504

[76] Inventor: **Chih Jen Chen**, P.O. Box 82-144,
Taipei, Taiwan

Primary Examiner—Joel Sincavage
Attorney, Agent, or Firm—A & J

[**] Term: **14 Years**

[57] **CLAIM**

[21] Appl. No.: **65,230**

The ornamental design for a retractable automotive battery cable housing, as shown and described.

[22] Filed: **Jan. 27, 1997**

DESCRIPTION

[51] **LOC (6) Cl.** **13-02**

[52] **U.S. Cl.** **D13/119; D8/359**

[58] **Field of Search** D13/120, 119,
D13/137.4; 439/504, 503, 507; D8/358,
359; 191/12.4, 12.2 R; 242/379, 379.2,
405.1, 405.2, 405.3

FIG. 1 is a perspective view of a retractable automotive battery cable housing showing my new design at an enlarged scale;

FIG. 2 is a front side elevational view thereof;

FIG. 3 is a rear side elevational view thereof;

FIG. 4 is a left view thereof;

FIG. 5 is a right view thereof;

FIG. 6 is a top plan view thereof; and,

FIG. 7 is a bottom plan view thereof.

[56] **References Cited**

U.S. PATENT DOCUMENTS

D. 257,576 12/1980 Bobroviczky D8/359

D. 310,207 8/1990 Sheps D13/184

1 Claim, 4 Drawing Sheets

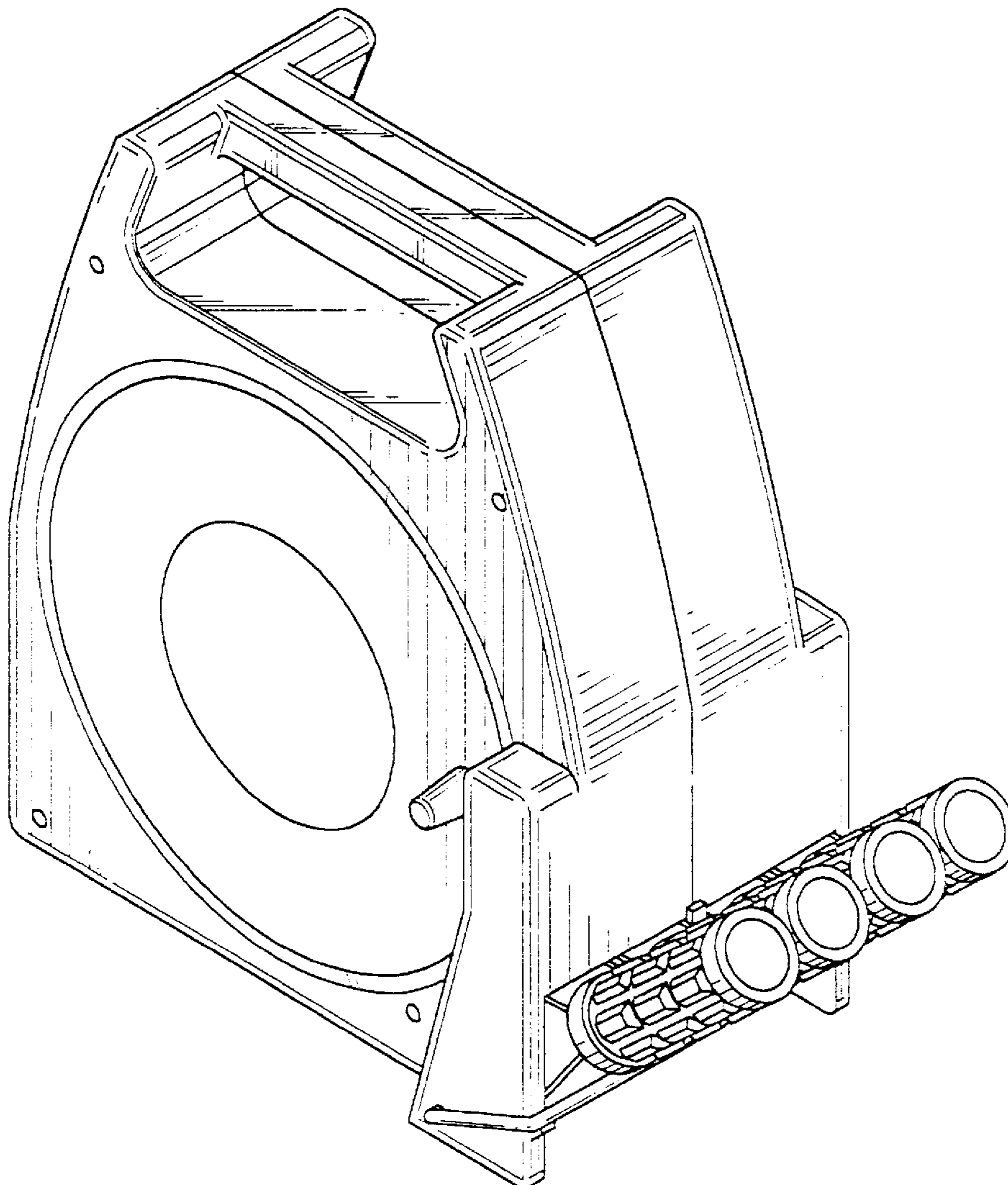

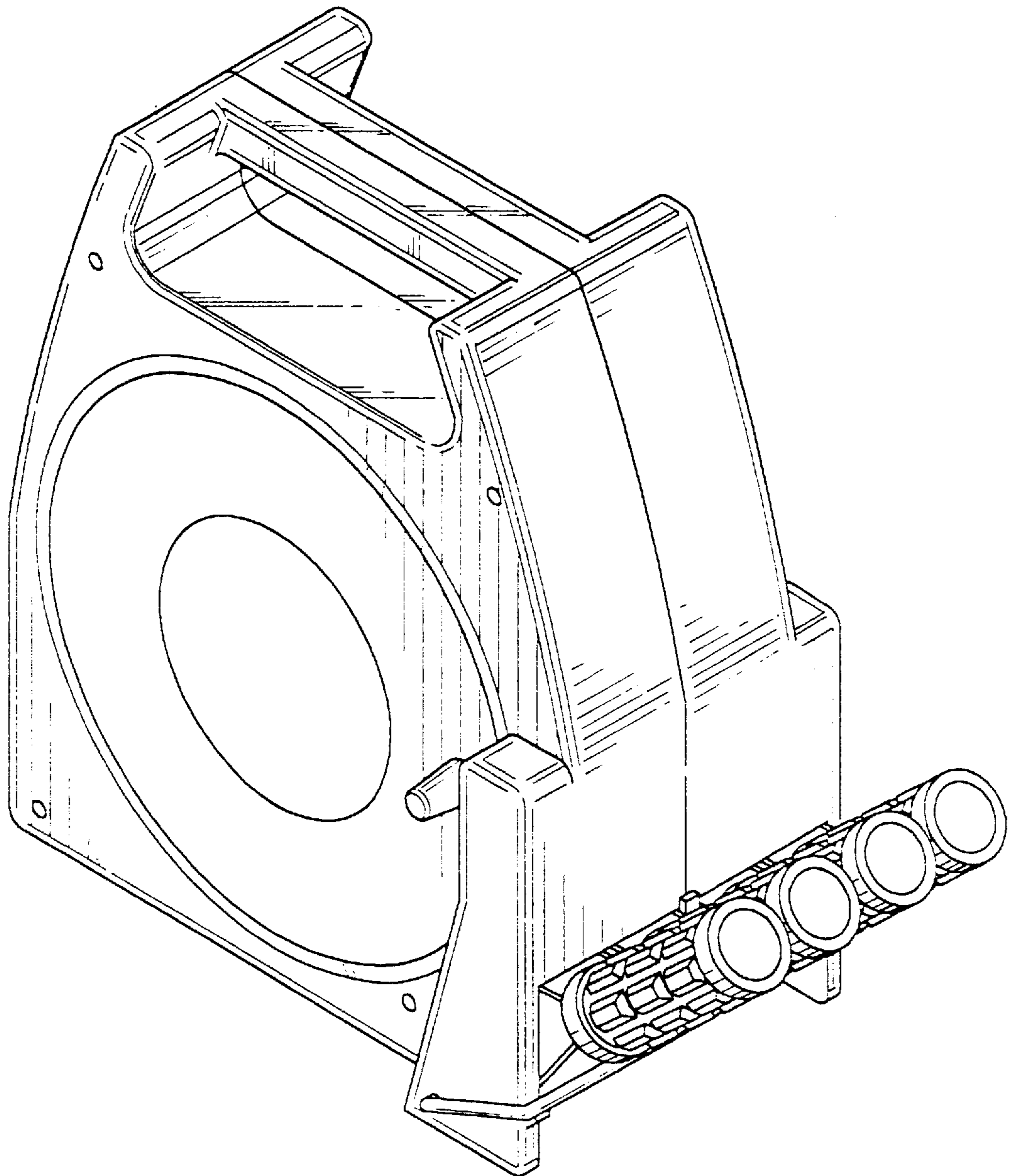

FIG. 1

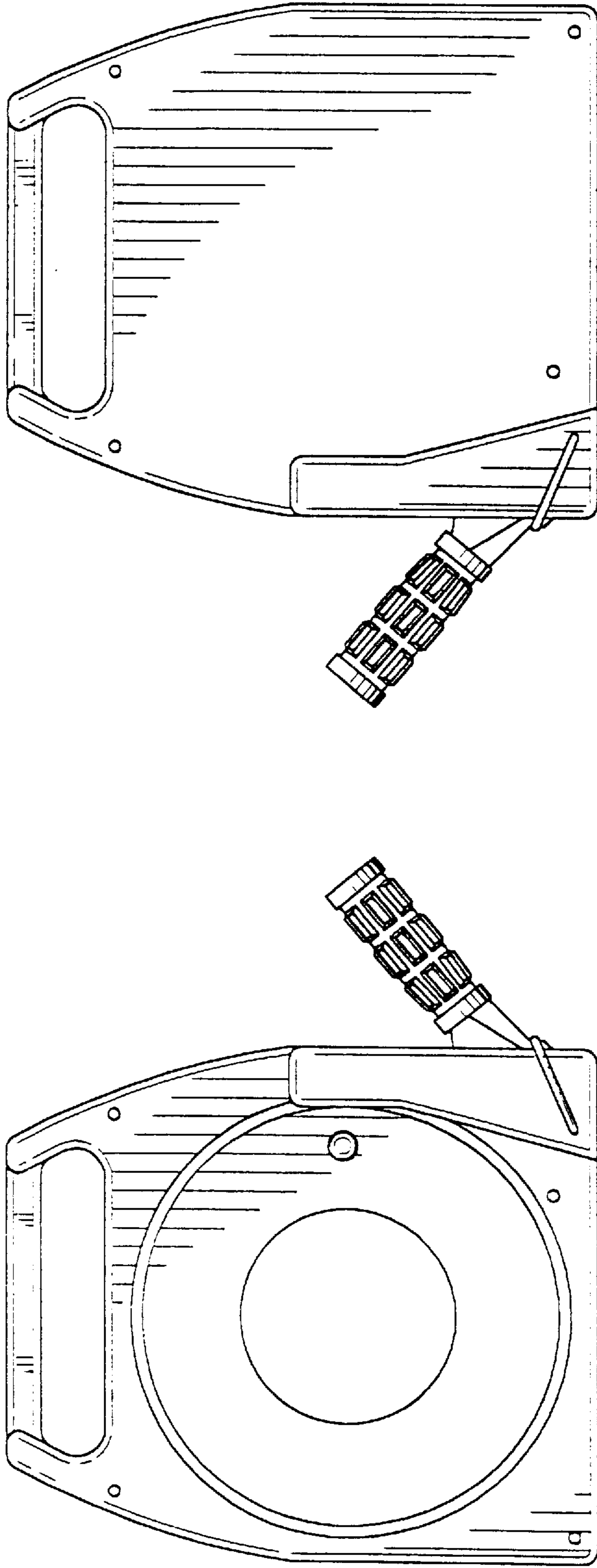

FIG. 3

FIG. 2

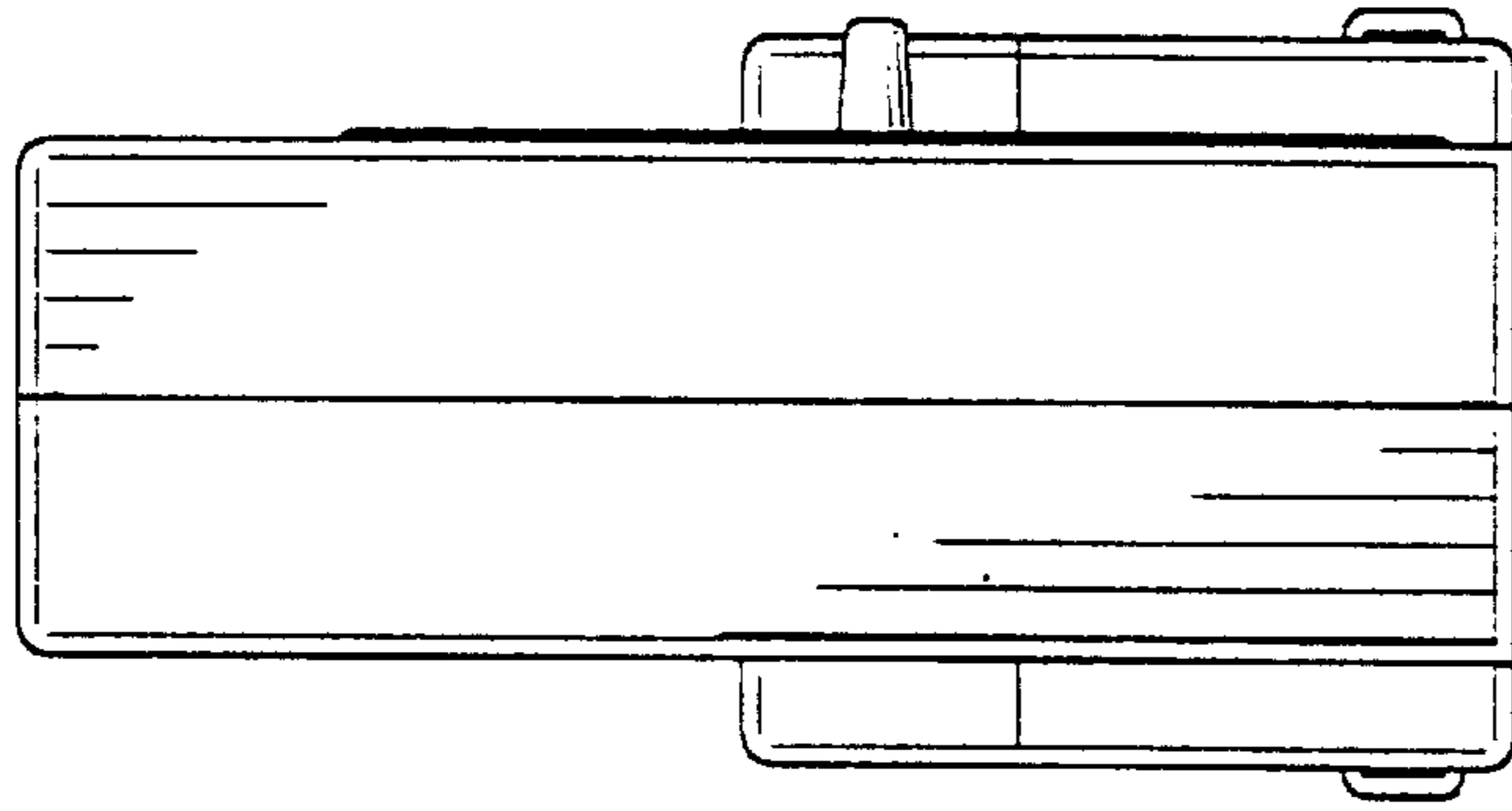

FIG. 5

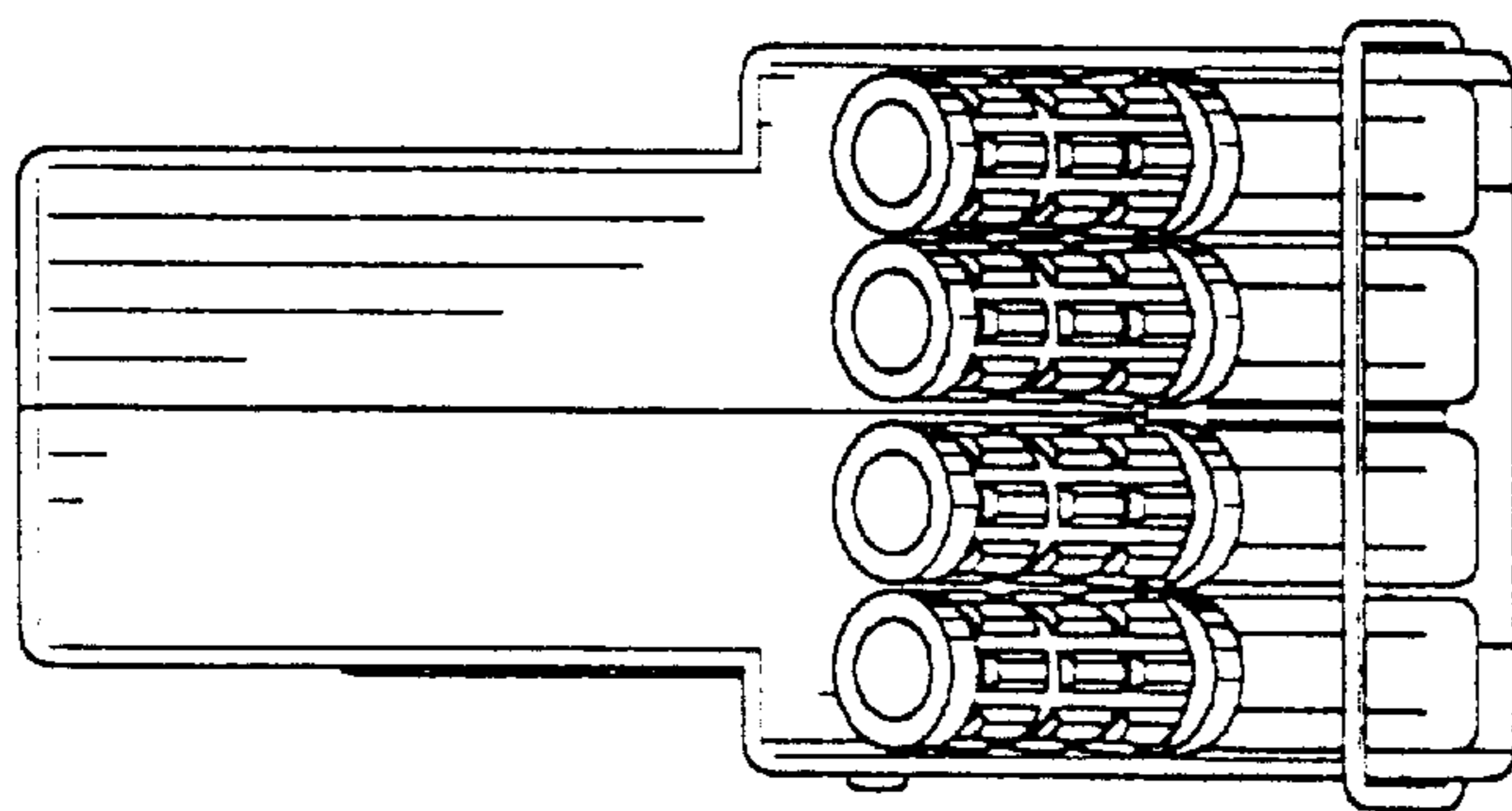

FIG. 4

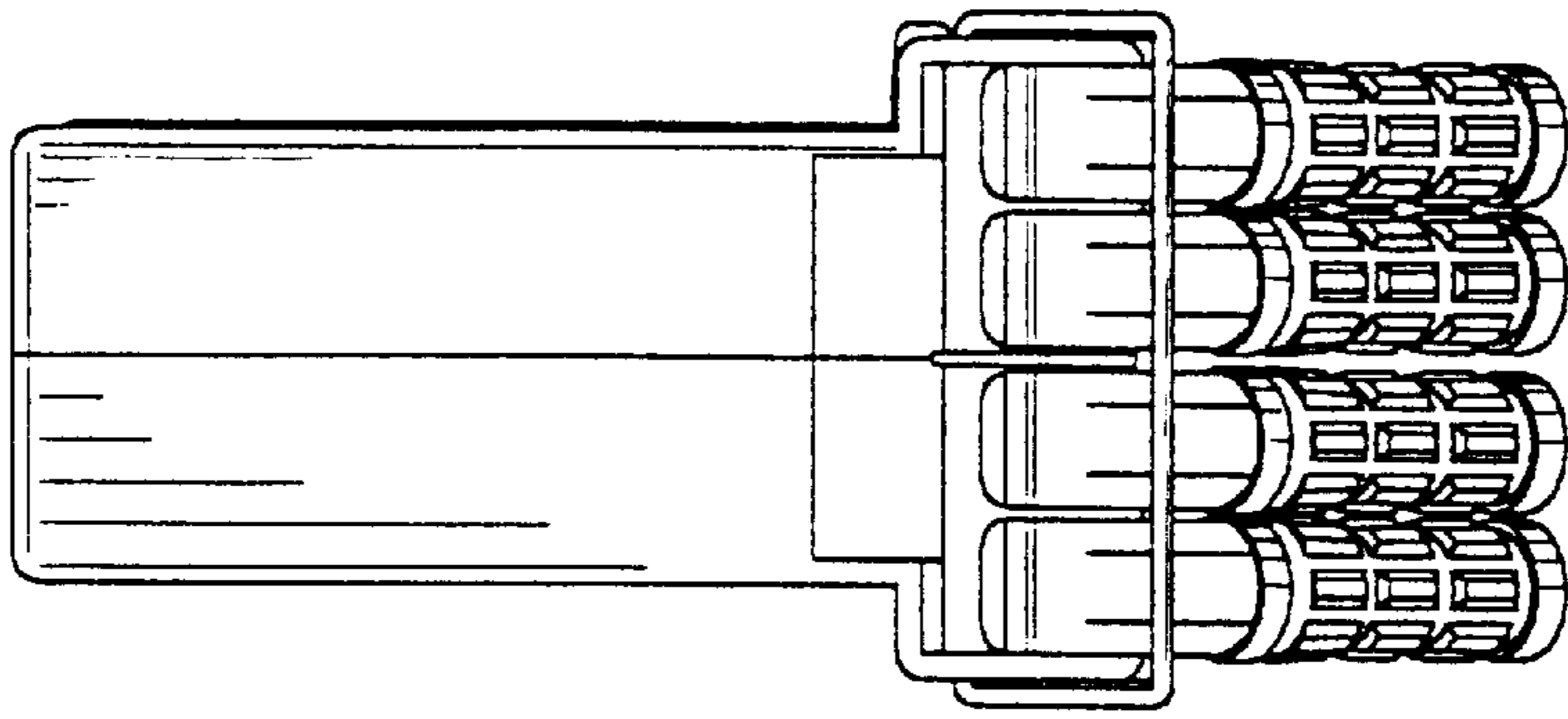

FIG. 7

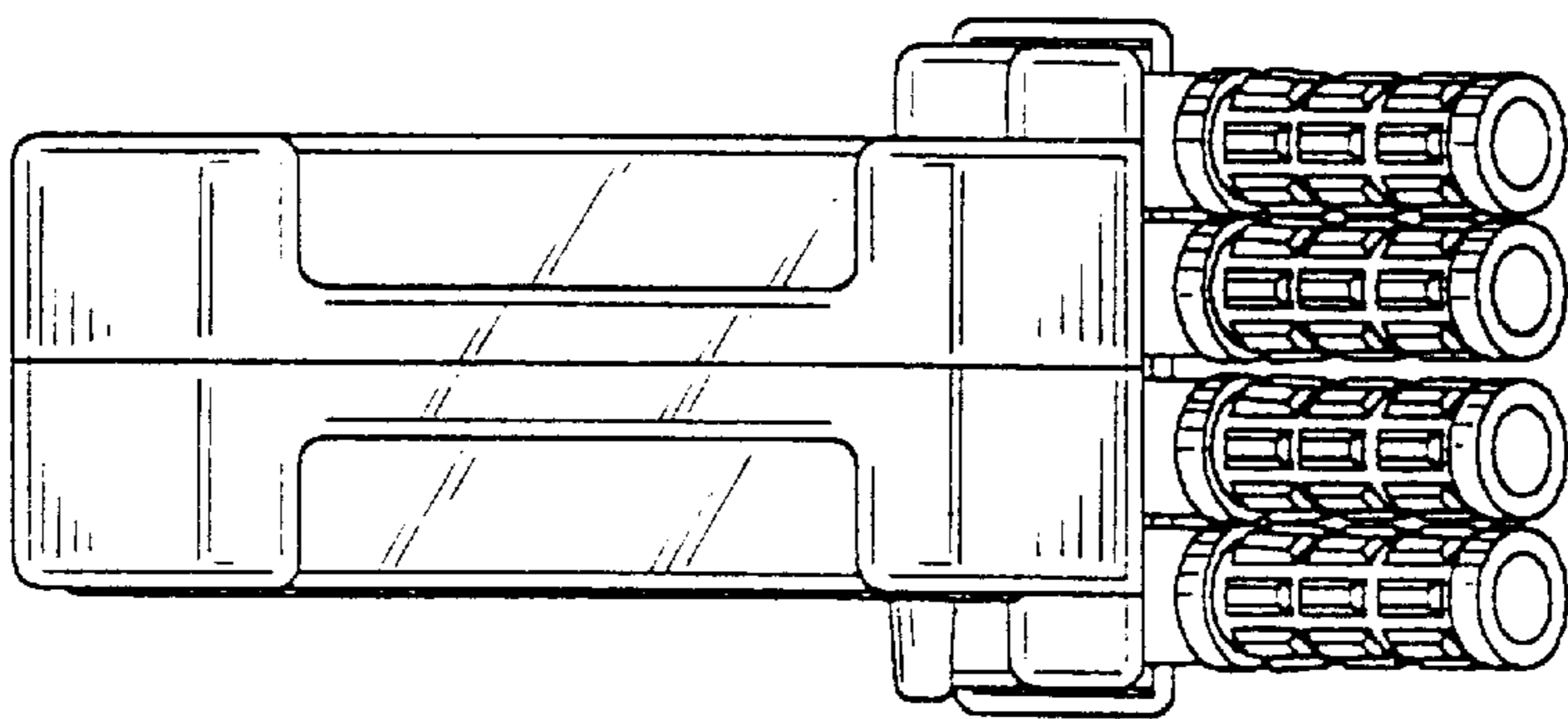

FIG. 6