



US00D400838S

United States Patent [19]
Stahel

[11] **Patent Number: Des. 400,838**

[45] **Date of Patent: **Nov. 10, 1998**

[54] **FLUSH MOUNT GAS CAP**

[76] Inventor: **Alwin J. Stahel**, 1244 Impenal La.,
New Brighton, Minn. 55112

[**] Term: **14 Years**

[21] Appl. No.: **71,718**

[22] Filed: **Jun. 5, 1997**

[51] **LOC (6) Cl.** **12-16**

[52] **U.S. Cl.** **D12/197**

[58] **Field of Search** D12/114, 197,
D12/198, 218; D23/260; 220/4.14, 288,
310.1, 378, DIG. 32, DIG. 33; 280/830

[56] **References Cited**

U.S. PATENT DOCUMENTS

D. 136,659	11/1943	Janning et al.	D12/197
D. 275,984	10/1984	Shaw	D23/260
3,129,014	4/1964	Hutchinson et al.	280/830
4,252,246	2/1981	Johnson et al.	220/288
4,320,853	3/1982	Moore	220/DIG. 33

OTHER PUBLICATIONS

Kawasaki Concours Fuel cap, illustration on top right corner of page, Cycle World Magazine, p. 73, May 1989.

Fuel Cap on Racing Motorcycle, Cycle World Magazine, p. 27, Jun. 1990.

Fuel Cap on Racing Motorcycle, Motorcyclist Magazine, p. 48, Jun. 1995.

Primary Examiner—James Gandy

Assistant Examiner—Robert M. Spear

[57] **CLAIM**

The ornamental design for a flush mount gas cap, as shown and described.

DESCRIPTION

FIG. 1 view in perspective as seen from the top and side;

FIG. 2 view in bottom plan;

FIG. 3 view in top plan;

FIG. 4 view in side elevation, all other side elevational views being substantially identical thereto; and,

FIG. 5 exploded view of the combined elements of the flush mount gas cap.

1 Claim, 2 Drawing Sheets

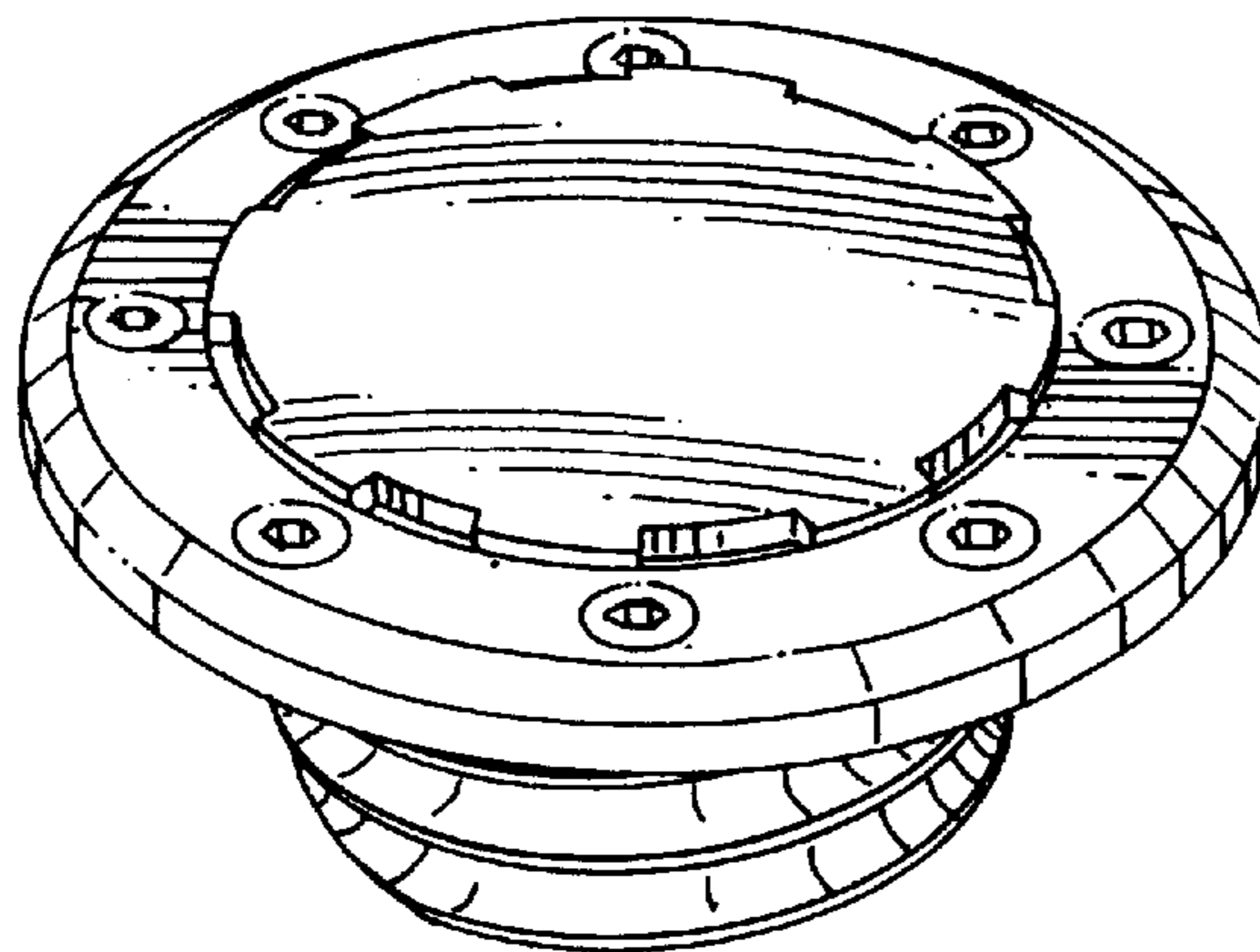

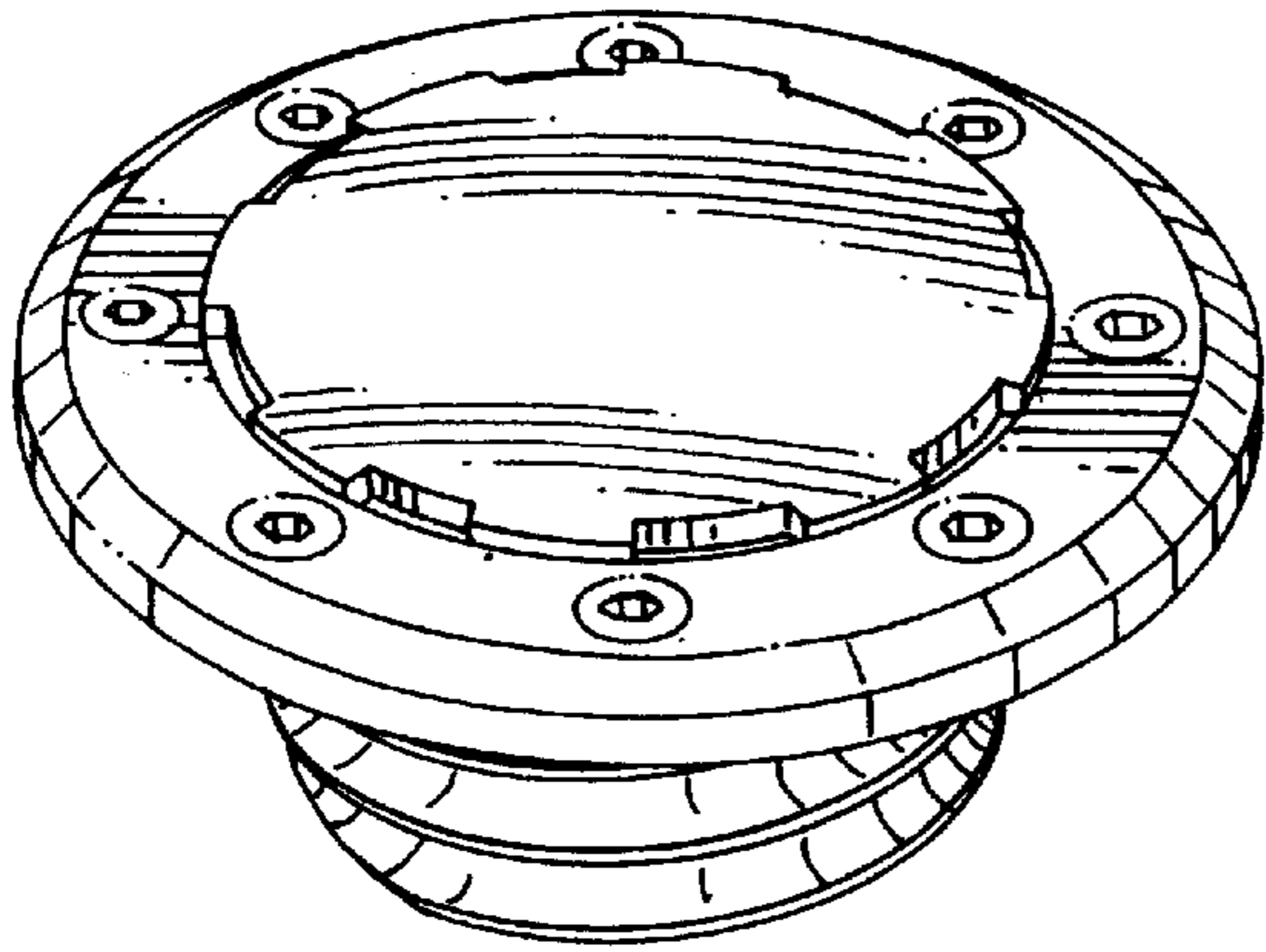

Fig. 1

Fig. 2

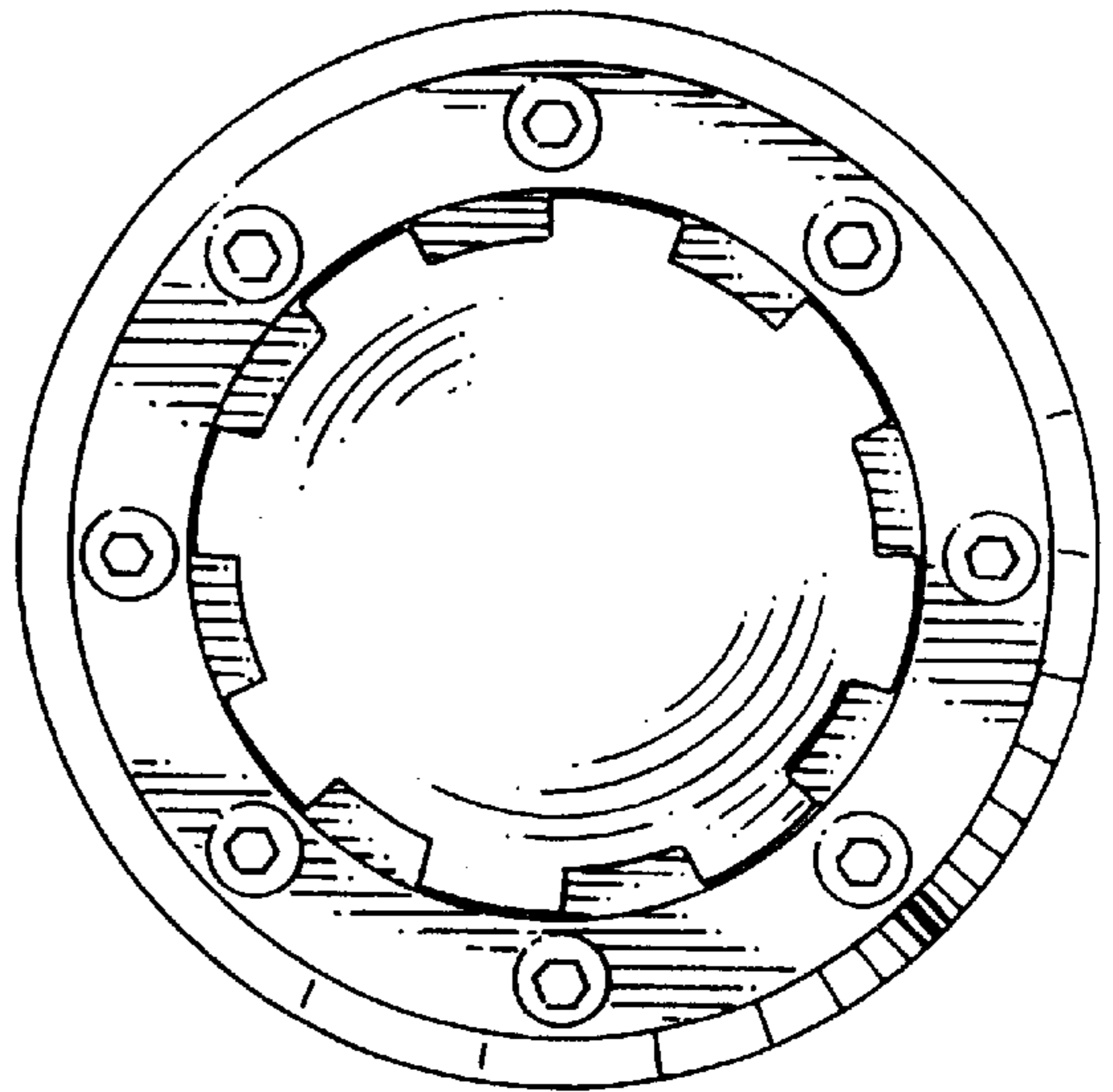
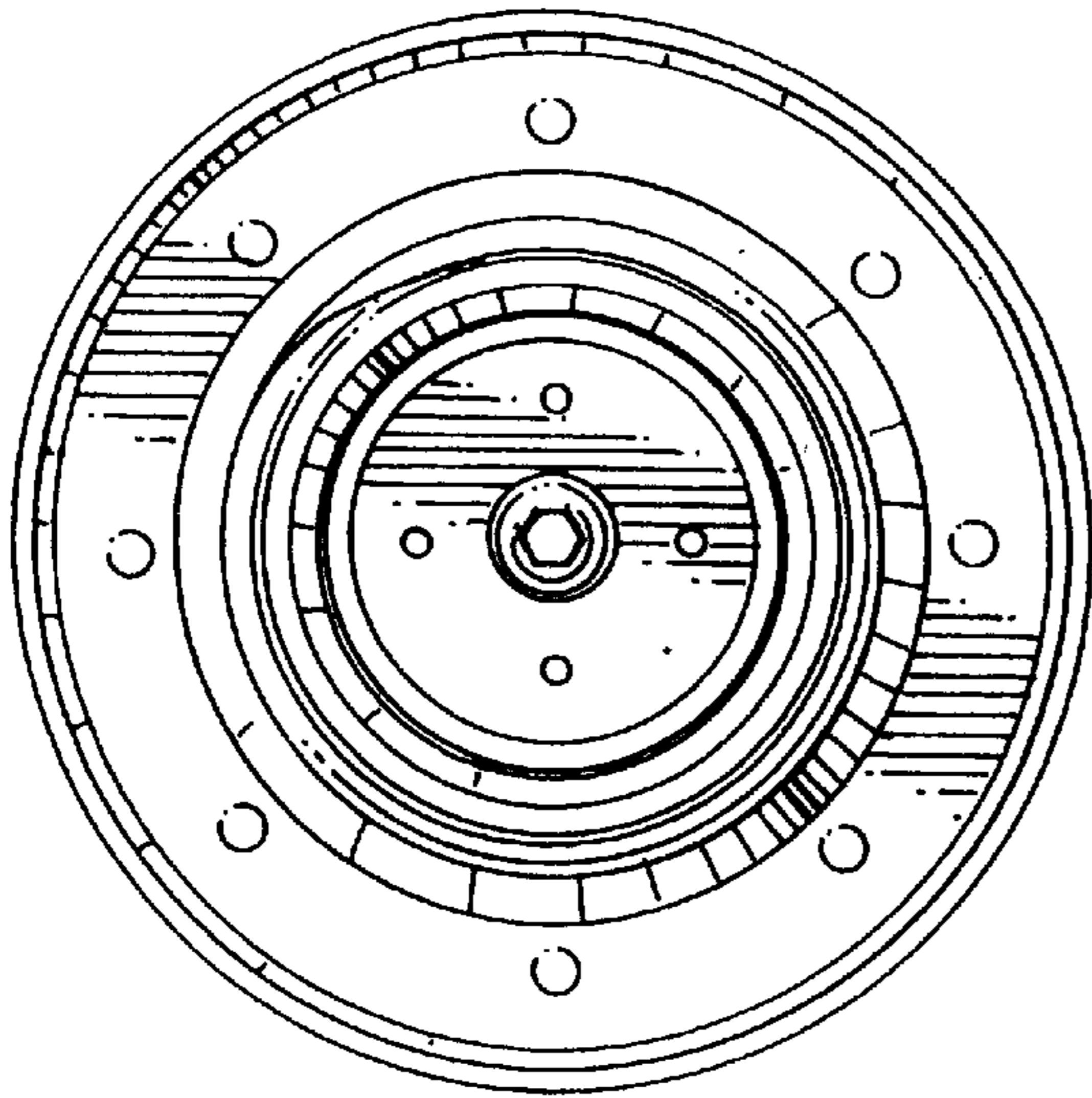

Fig. 3

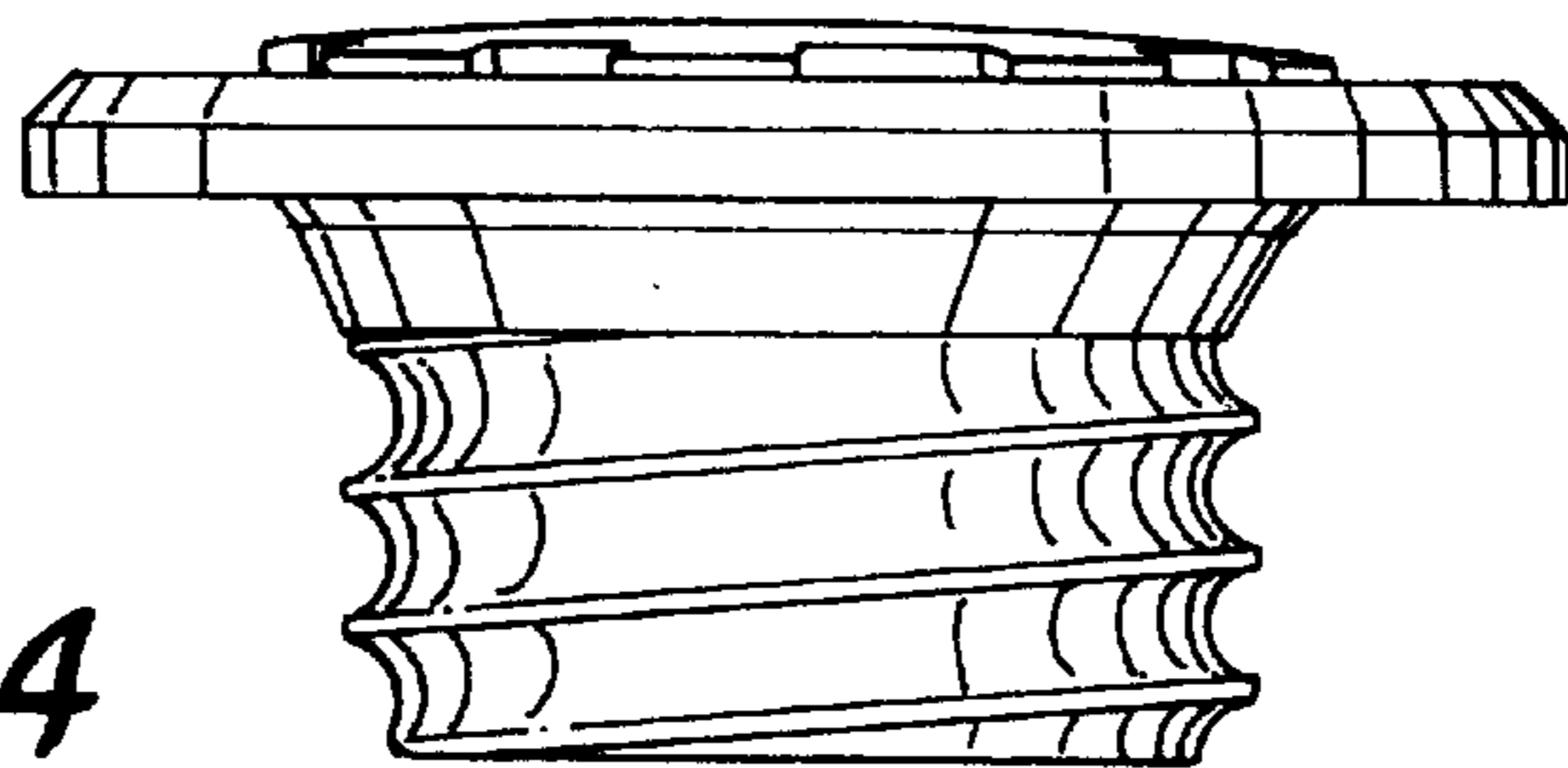

Fig. 4

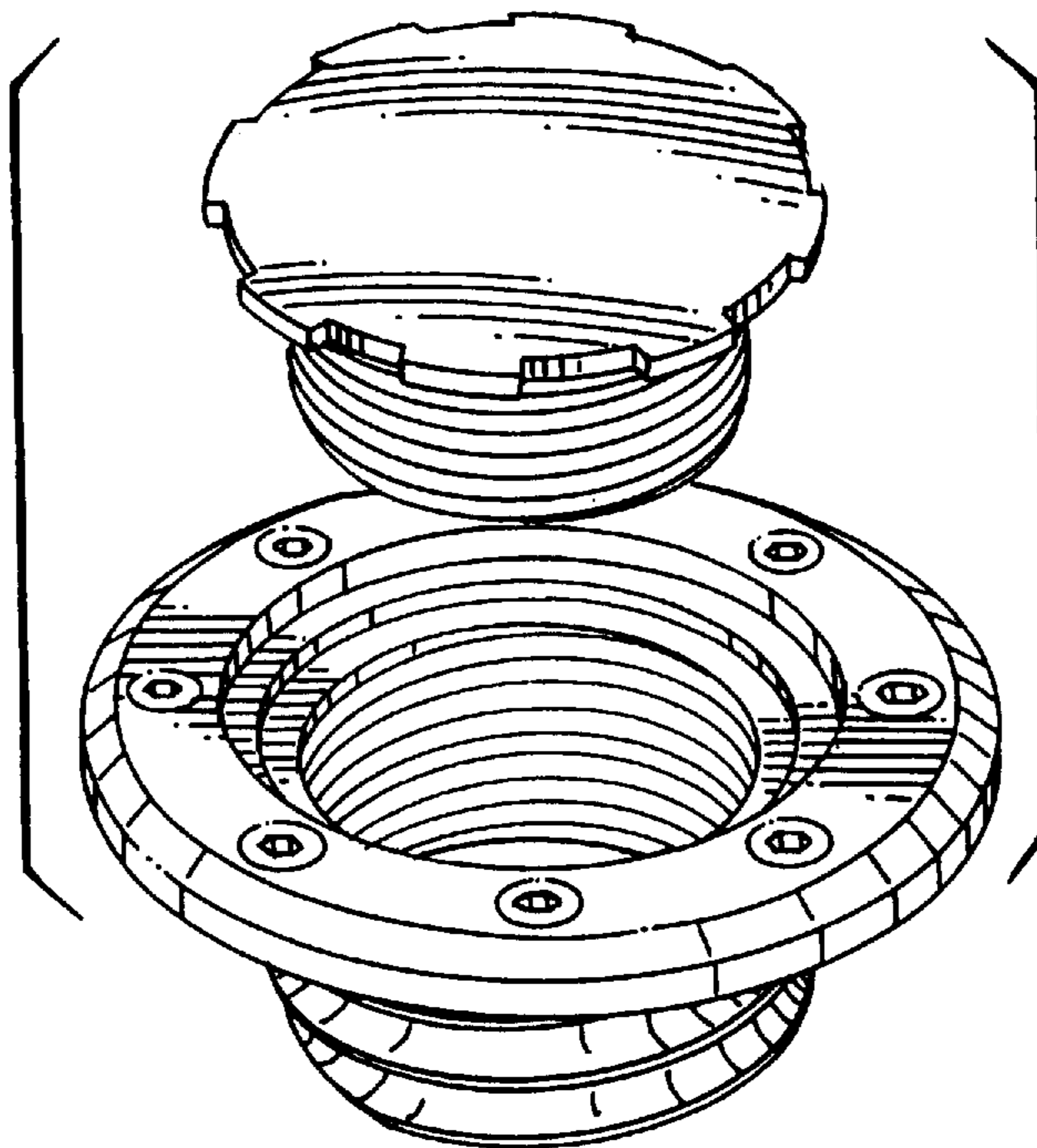

Fig. 5