



US00D400837S

United States Patent [19] Pitts

[11] **Patent Number: Des. 400,837**

[45] **Date of Patent: **Nov. 10, 1998**

[54] **GRAPPLE DEFLECTOR FOR LOGGING TRAILER**

4,098,535 7/1978 Berger 280/763.1
5,586,785 12/1996 Warner et al. 280/762

[75] Inventor: **Jeffery Beauregard Pitts**, Pittsview, Ala.

Primary Examiner—Robert M. Spear
Attorney, Agent, or Firm—Veal & Associates

[73] Assignee: **Pitts Enterprises, Inc.**, Pittsview, Ala.

[57] **CLAIM**

[**] Term: **14 Years**

The ornamental design for a grapple deflector for logging trailer, as shown and described.

[21] Appl. No.: **71,057**

DESCRIPTION

[22] Filed: **May 19, 1997**

FIG. 1 is a front perspective view of a grapple deflector for logging trailer showing my new design;

[51] **LOC (6) Cl.** **12-16**

FIG. 2 is a rear perspective view;

[52] **U.S. Cl.** **D12/181**

FIG. 3 is a top plan view thereof;

[58] **Field of Search** D12/106, 181,
D12/400, 406, 414; 280/404, 762, 763.1,
770; 296/36, 180.1, 181

FIG. 4 is a front side elevational view, the rear side being a mirror image thereof;

FIG. 5 is a side elevational view as seen from the right side of FIG. 4;

[56] **References Cited**

U.S. PATENT DOCUMENTS

D. 172,035	4/1954	Krusemark	D12/181
D. 240,519	7/1976	Richter et al.	D12/181
381,479	4/1888	Manlove et al.	296/36
553,171	1/1896	Markussen	296/36
630,032	8/1899	Carskadon	296/36
2,717,802	9/1955	Martin	280/762
4,063,750	12/1977	Mutchler	280/763.1

FIG. 6 is a side elevational view as seen from the left side of FIG. 4;

FIG. 7 is a bottom view thereof; and,

FIG. 8 is a reduced scale perspective view of the present invention mounted on a trailer which is shown in broken lines to illustrate environmental structure. The broken line showing of the trailer forms no part of the claimed design.

1 Claim, 3 Drawing Sheets

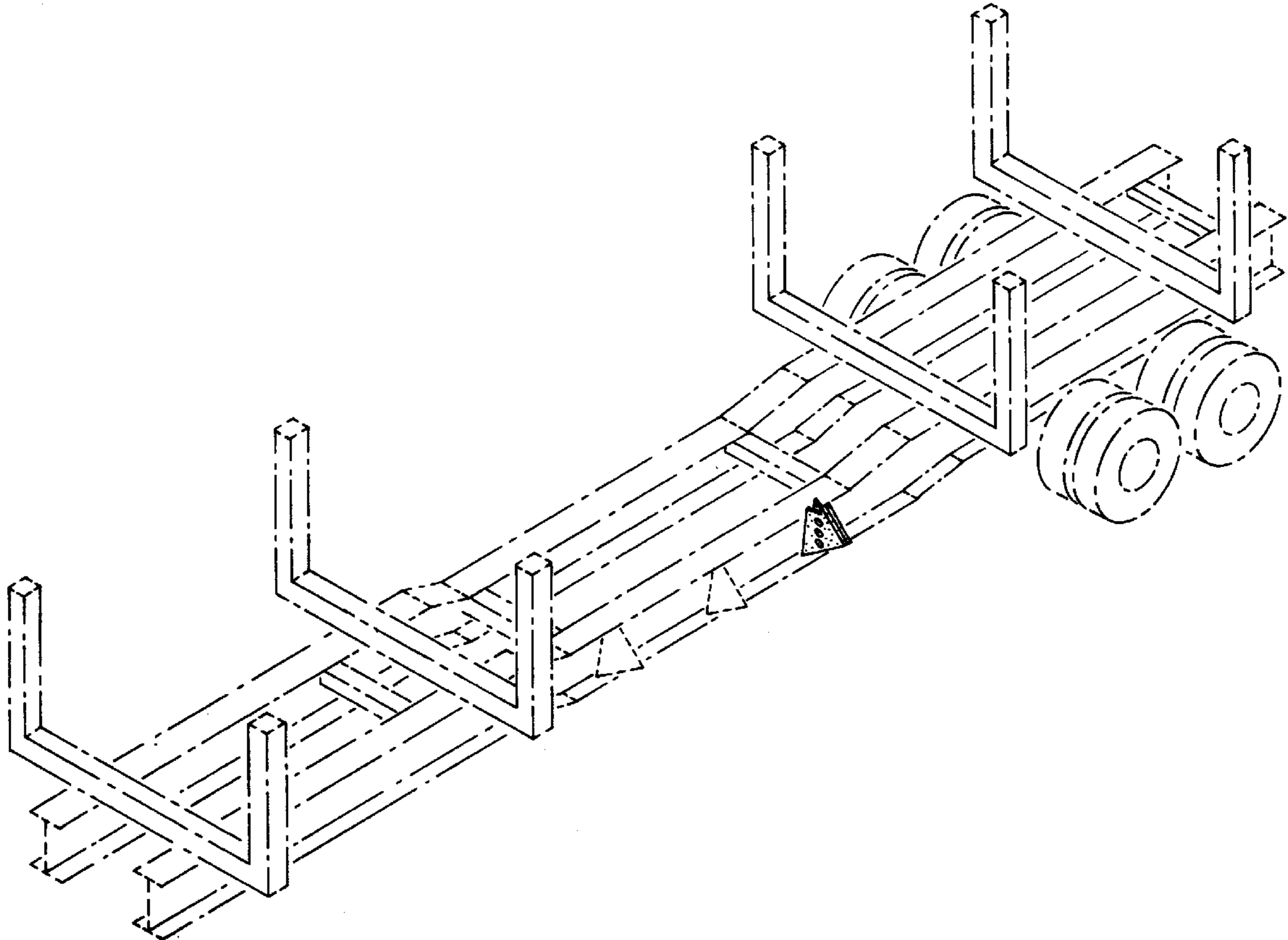

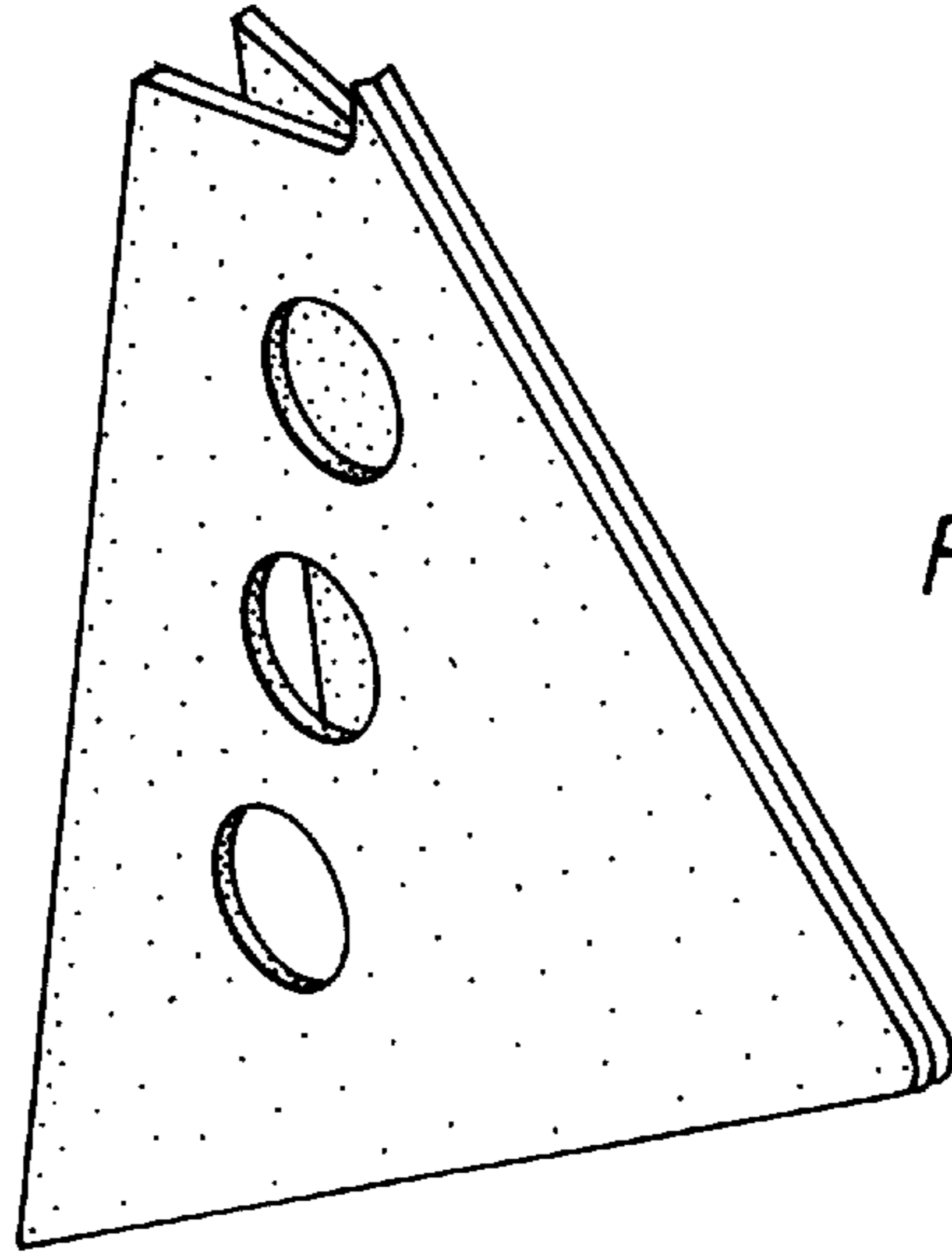

Fig. 1

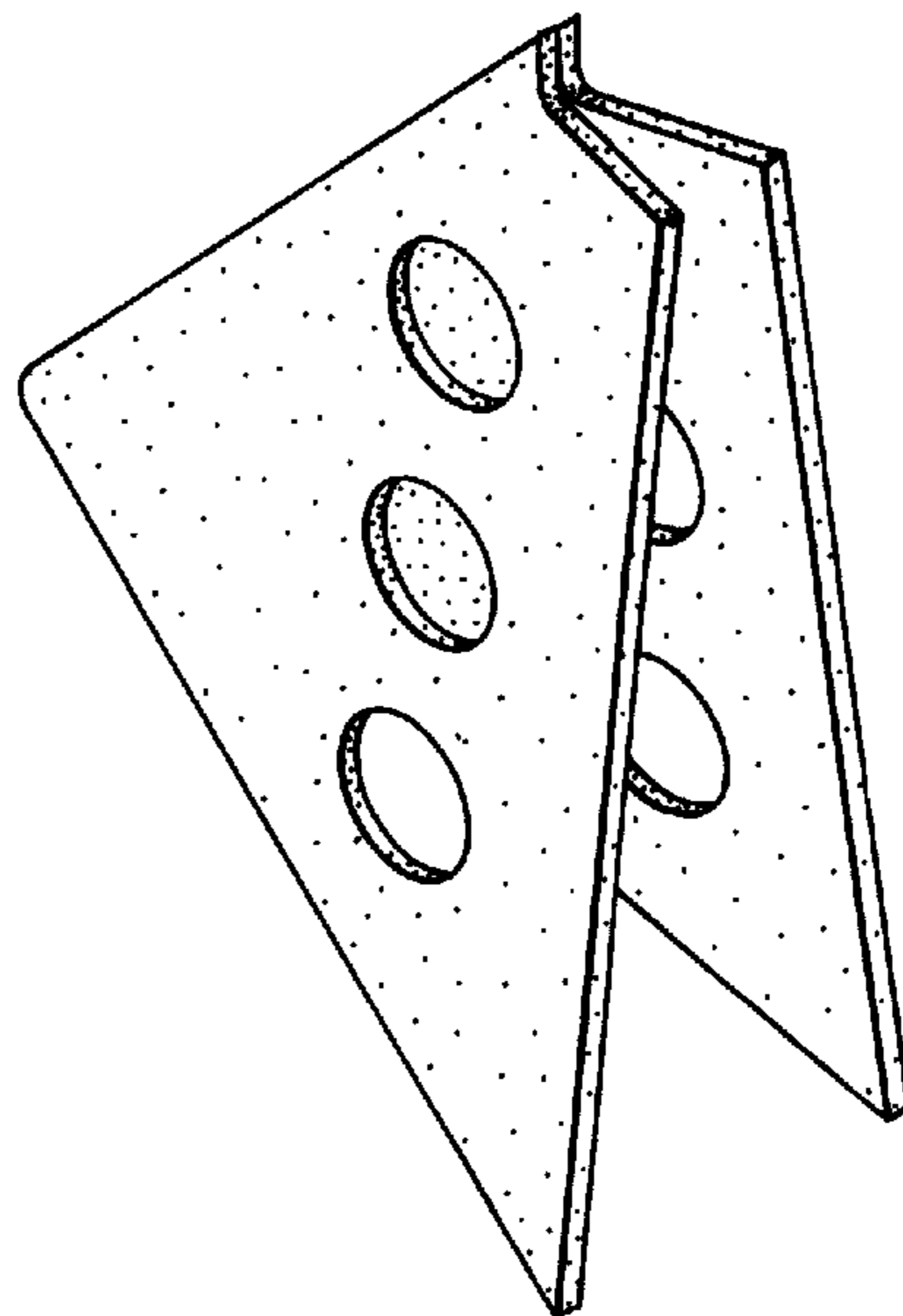

Fig. 2

Fig. 3

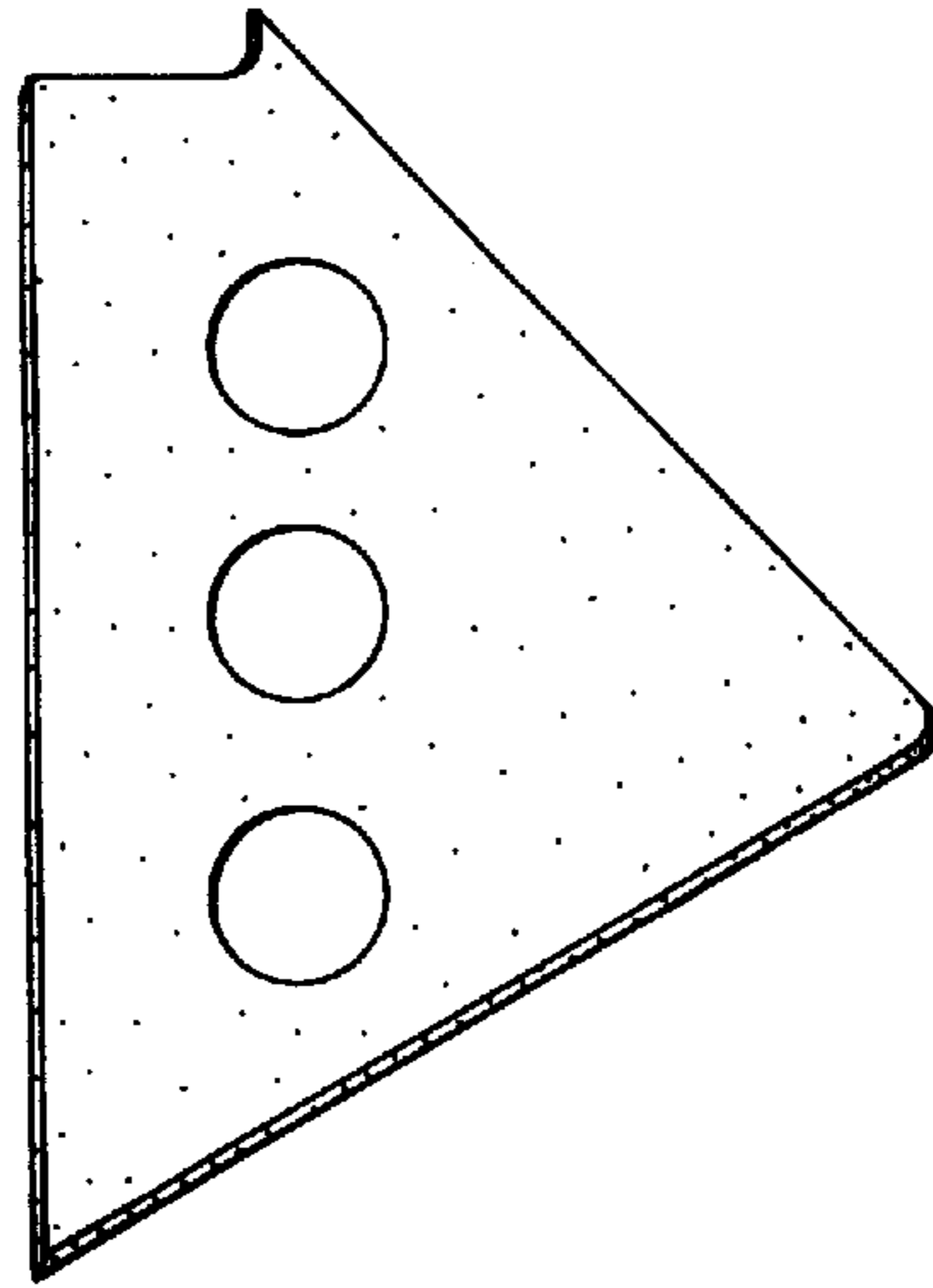
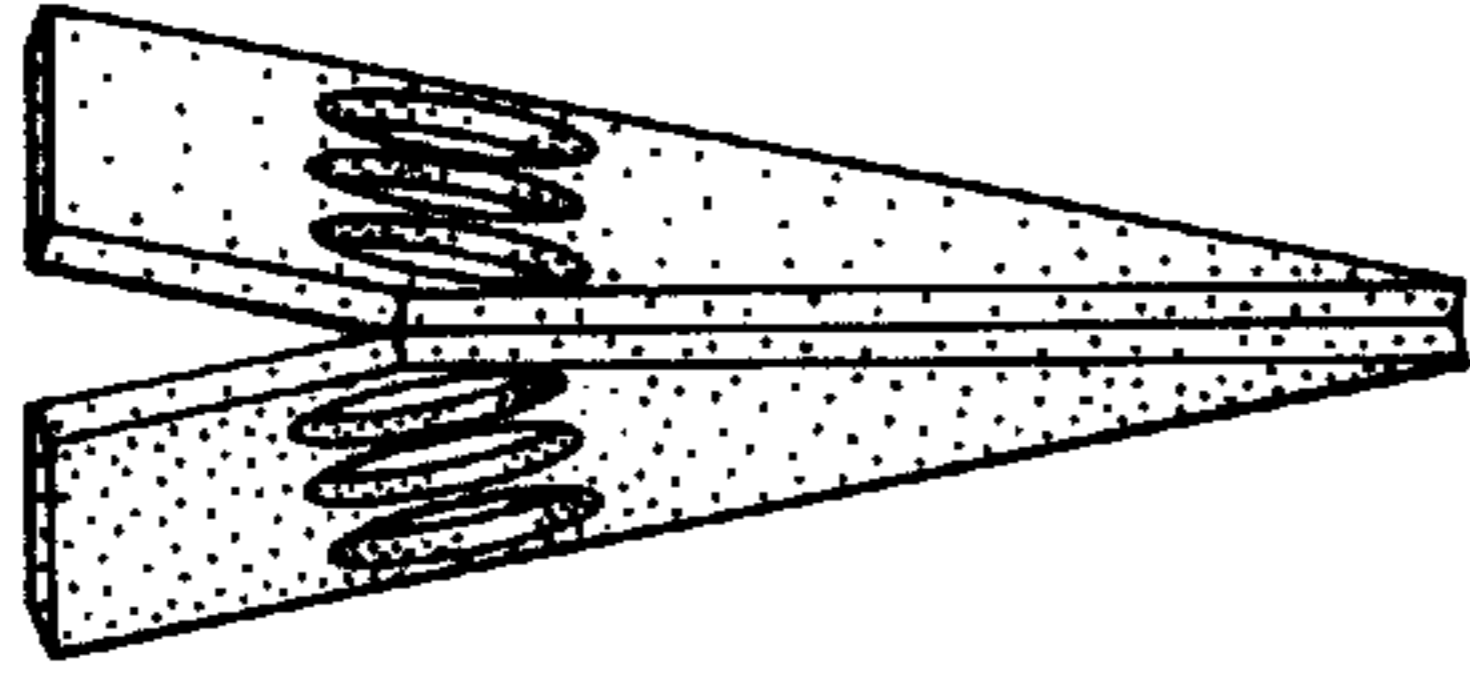

Fig. 4

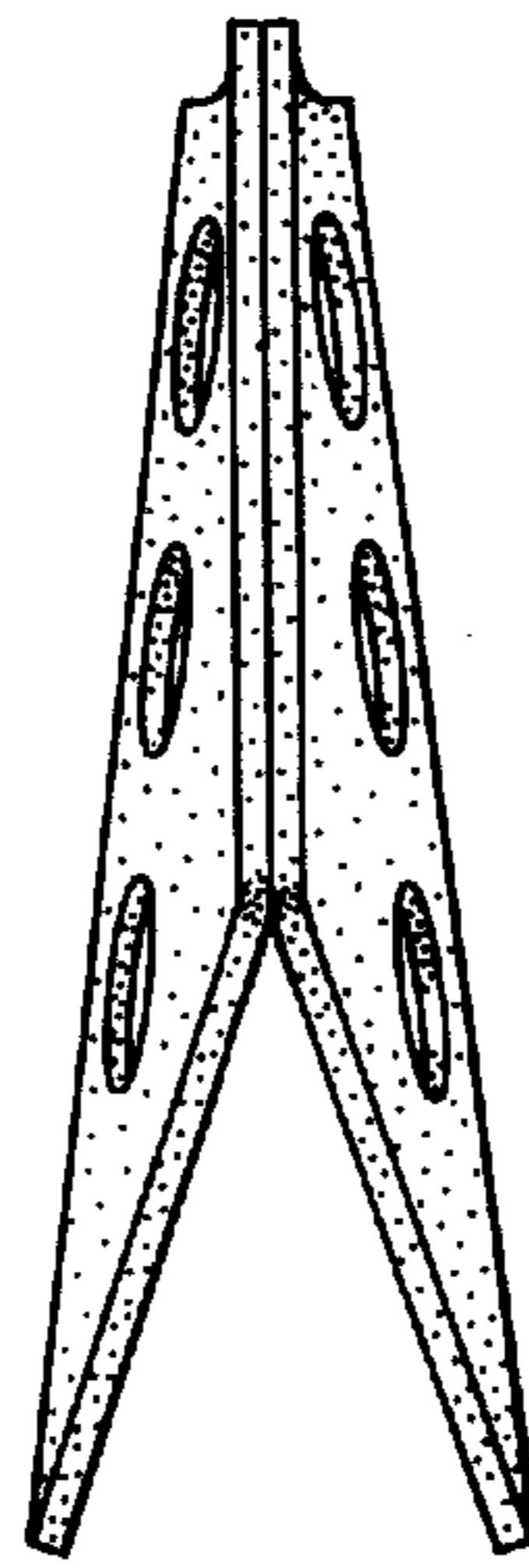

Fig. 5

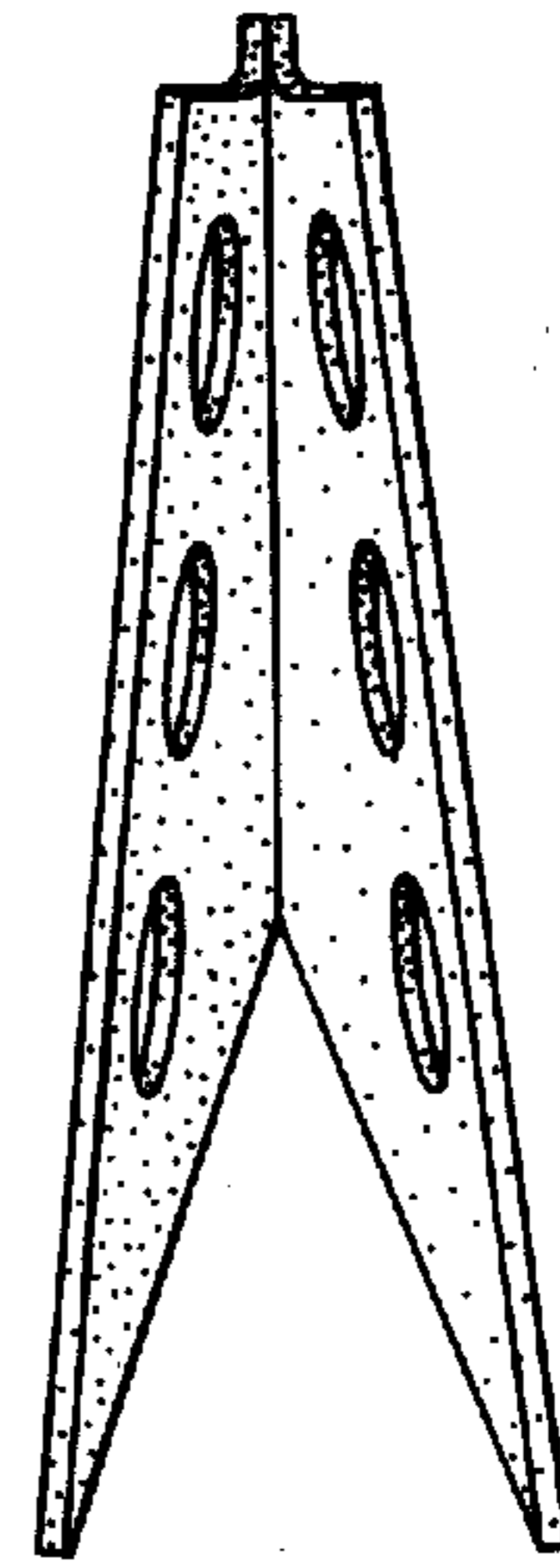

Fig. 6

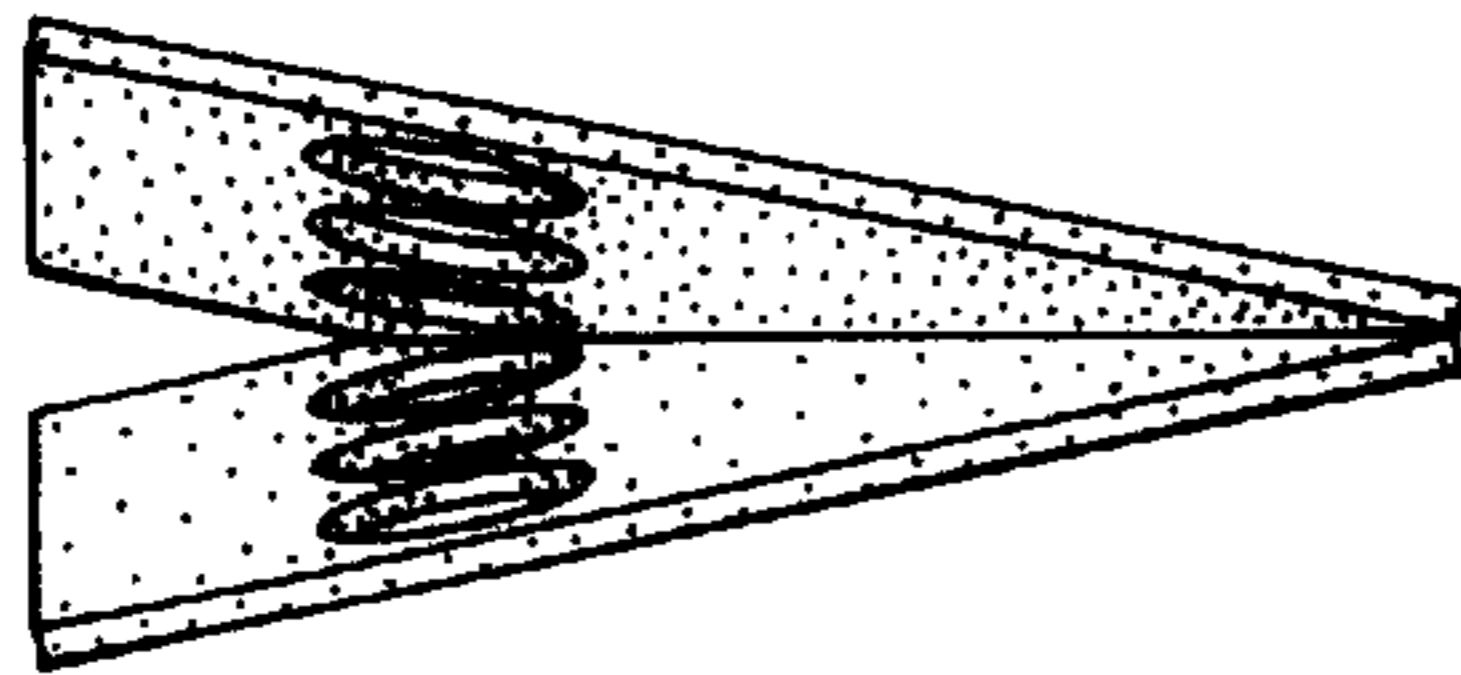

Fig. 7

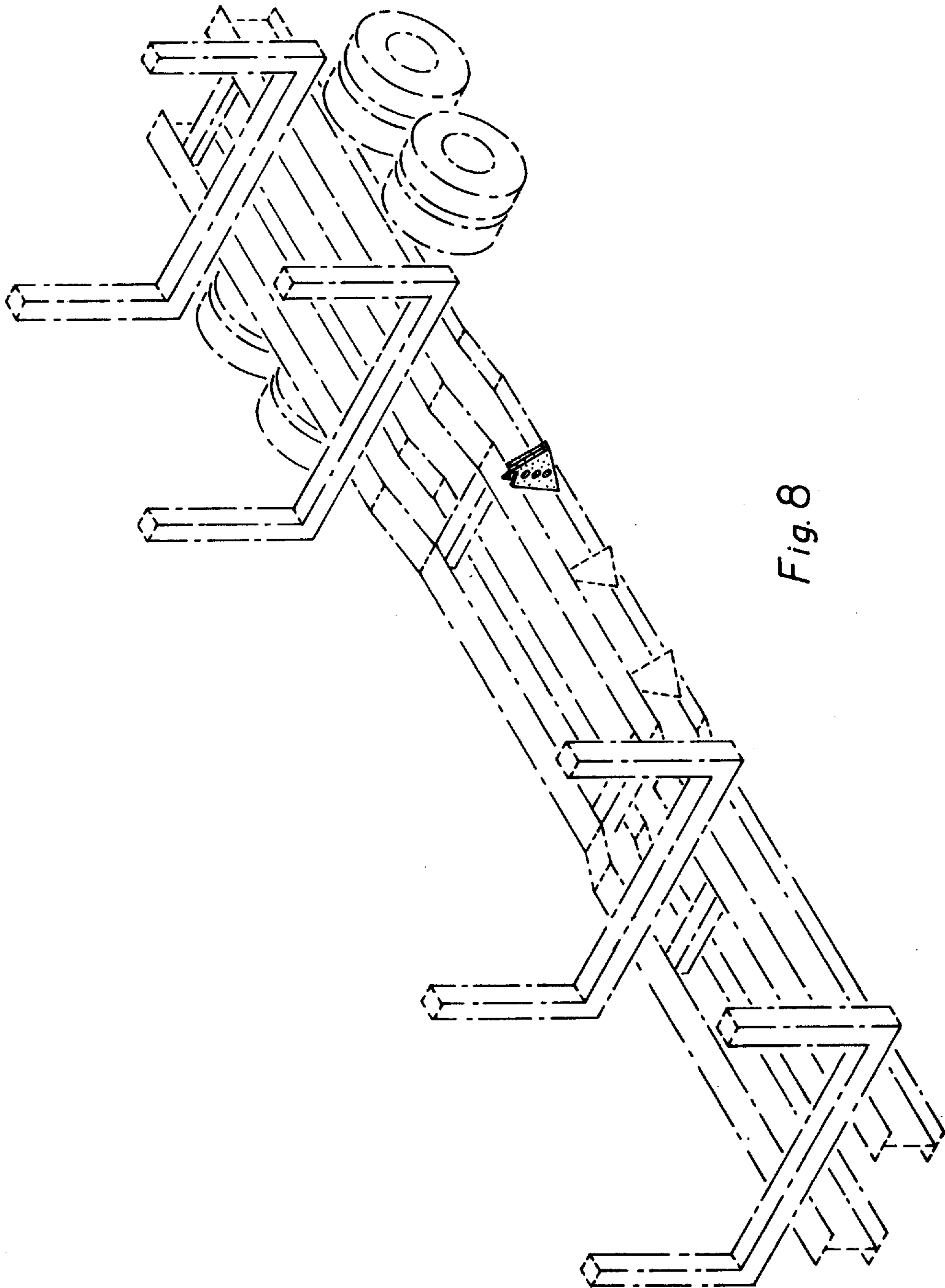

Fig. 8