



US00D400742S

United States Patent [19] Jackson

[11] **Patent Number: Des. 400,742**

[45] **Date of Patent: **Nov. 10, 1998**

[54] **UNDER SEAT TACKLE BOX**

[76] Inventor: **Phillip H. Jackson**, 70 Harold Dr.,
Paris, Tenn. 38242

[**] Term: **14 Years**

[21] Appl. No.: **72,716**

[22] Filed: **Jun. 23, 1997**

[51] **LOC (6) Cl. 06-06**

[52] **U.S. Cl. D6/500; D6/336**

[58] **Field of Search D6/334, 335, 336,
D6/364, 500, 501, 502, 396, 397; D3/274,
297, 260; D12/416; D24/134; 43/54.1,
55; 297/188.11, 192, 447.4**

[56] **References Cited**

U.S. PATENT DOCUMENTS

D. 167,595	8/1952	Simmons	D6/336
210,487	12/1878	Bovey	312/235.2
D. 274,581	7/1984	Gallock	D6/336
D. 279,437	7/1985	Downey, Jr.	D6/375
D. 293,047	12/1987	Highfield	D6/335
D. 293,632	1/1988	Capocasa	D6/336
D. 311,292	10/1990	Ennis, Jr.	D6/510
D. 316,785	5/1991	Beane	D6/336
D. 345,865	4/1994	Tintori	D6/336
D. 348,904	7/1994	Linder	D6/511 X
878,267	2/1908	Baker	297/447.4
3,545,809	12/1970	Krenz	297/217
3,623,683	11/1971	Bennett	297/192
4,067,607	1/1978	Battles	297/192

4,624,502	11/1986	Boole	297/192
4,887,379	12/1989	Harrison	43/54.1
5,520,436	5/1996	Rader et al.	297/188.11
5,560,145	10/1996	Anderson	43/54.1

Primary Examiner—Gary D. Watson
Attorney, Agent, or Firm—David L. Volk

[57] **CLAIM**

The ornamental design for an under seat tackle box, as shown and described.

DESCRIPTION

FIG. 1 is a perspective view of an under seat tackle box showing my new design;
FIG. 2 is a perspective view thereof, shown without the environmental structure;
FIG. 3 is a right side elevational view thereof, the opposite side being a mirror image;
FIG. 4 is a front elevational view thereof;
FIG. 5 is a rear elevational view thereof;
FIG. 6 is a top plan view thereof;
FIG. 7 is a bottom view thereof; and,
FIG. 8 is a perspective view thereof, shown with the drawer closed.

The broken line illustration shows environmental structure and forms no part of the claimed invention.
The portions of the under seat tackle box which have not been shown or described form no part of the claimed design.
FIGS. 2 through 8 have been shown on an enlarged scale with respect to FIG. 1.

1 Claim, 6 Drawing Sheets

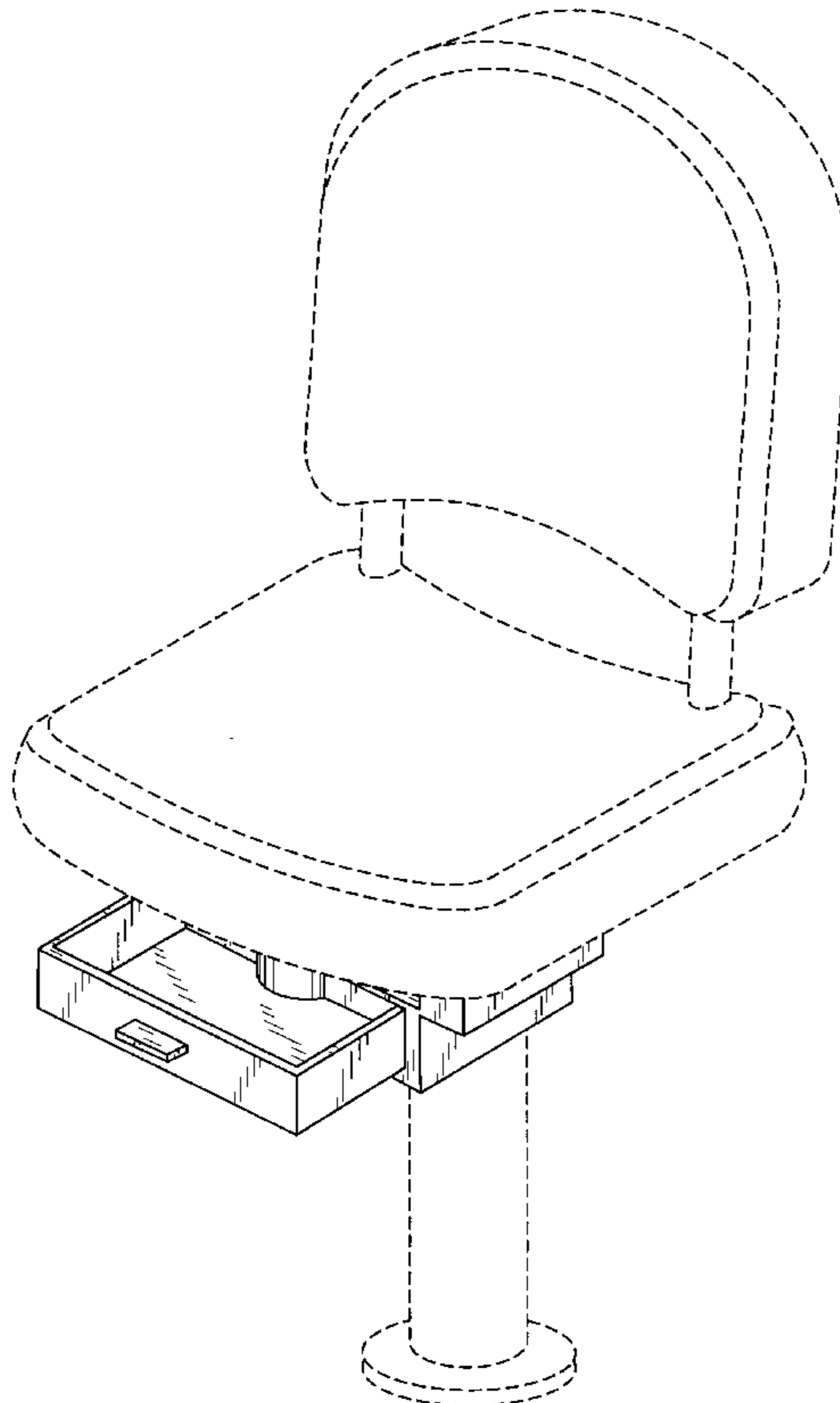

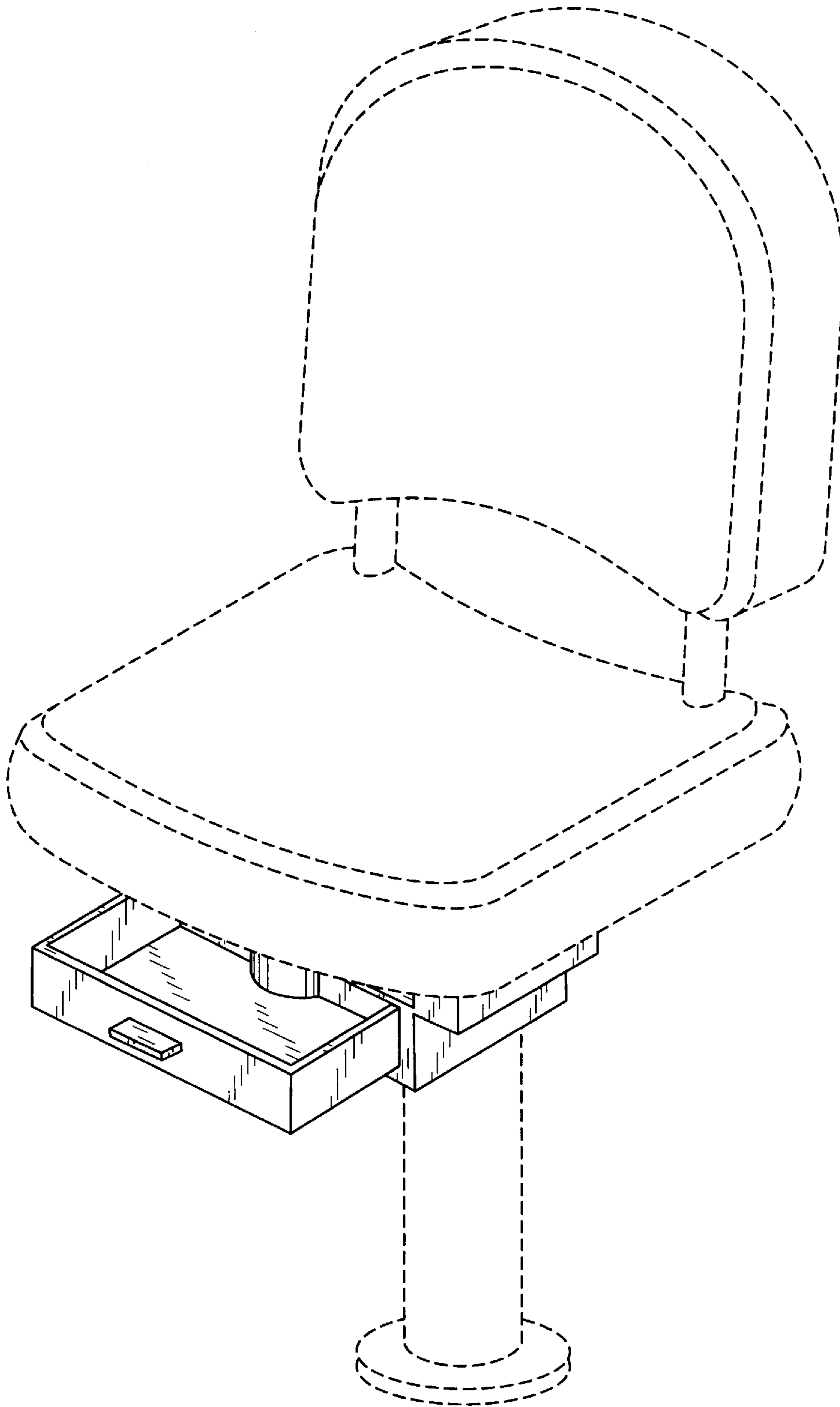

Fig. 1

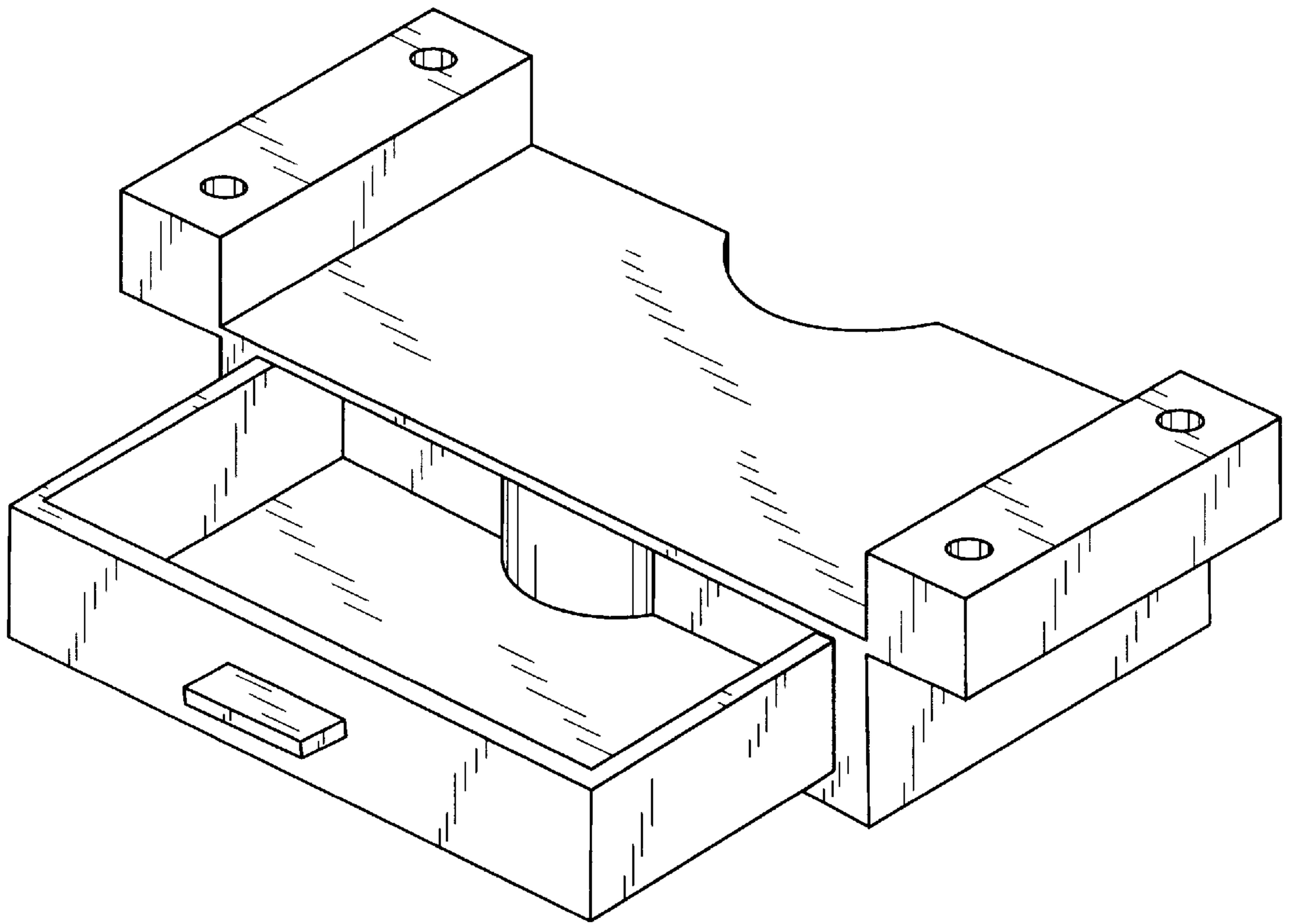

Fig. 2

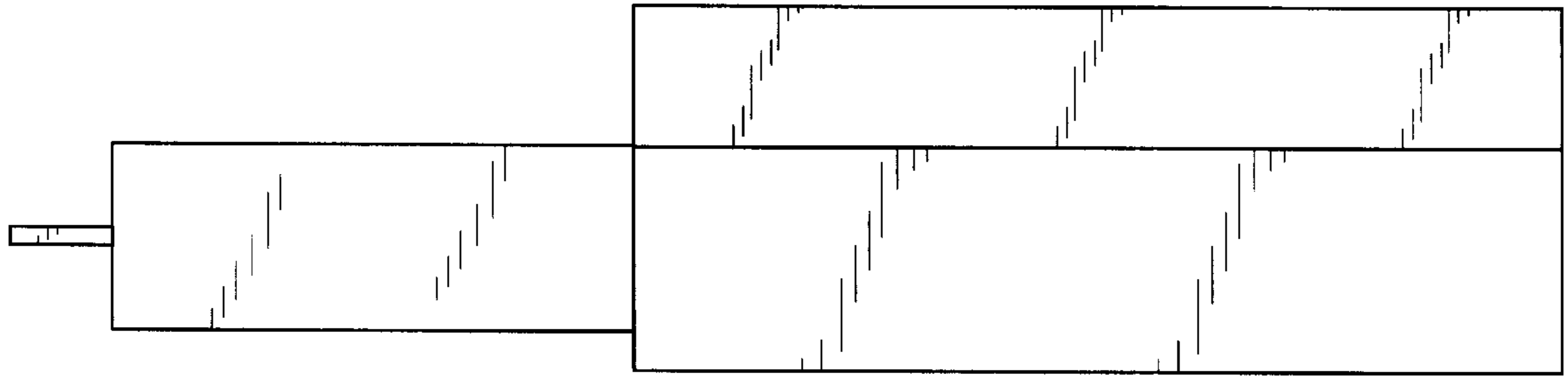

Fig. 3

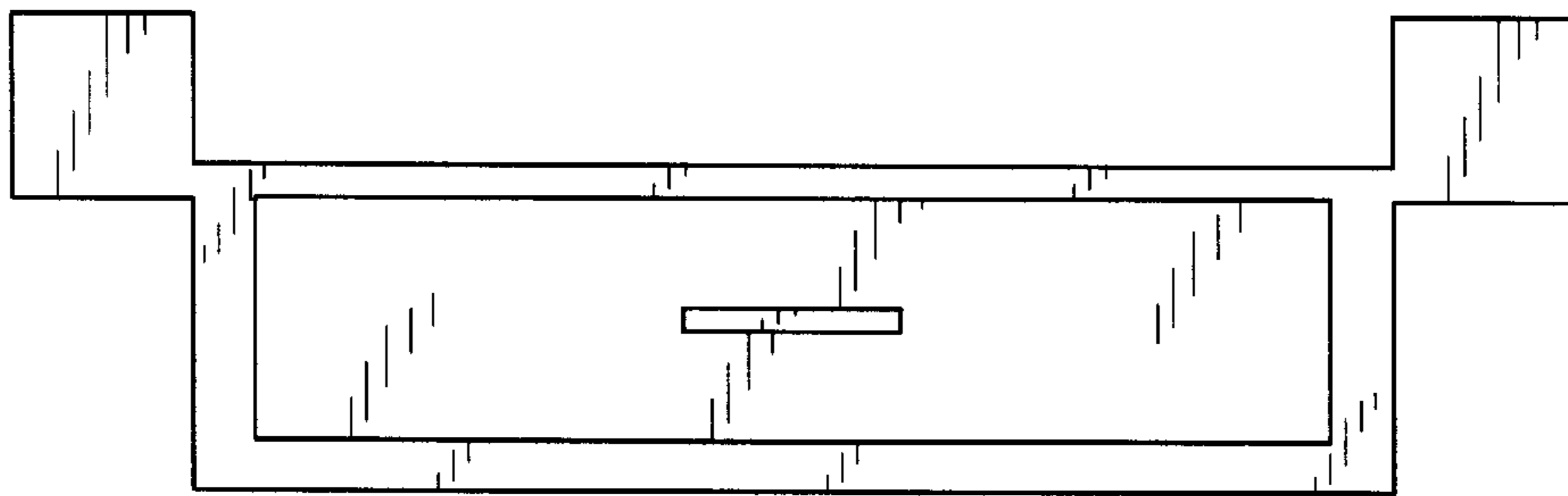

Fig. 4

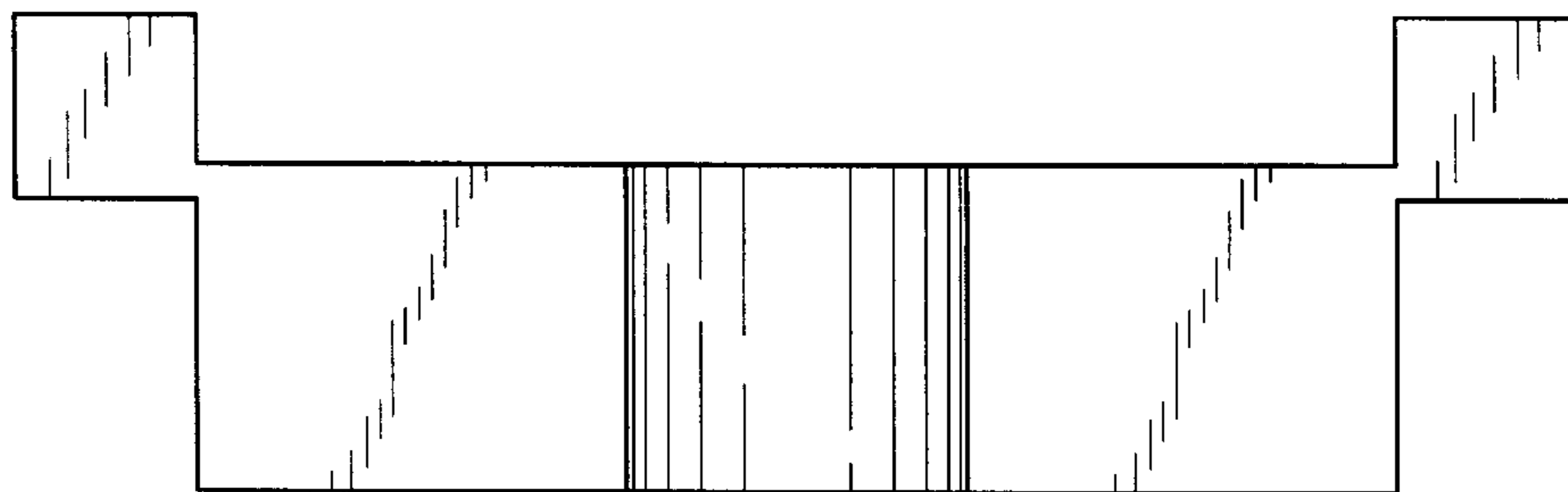

Fig. 5

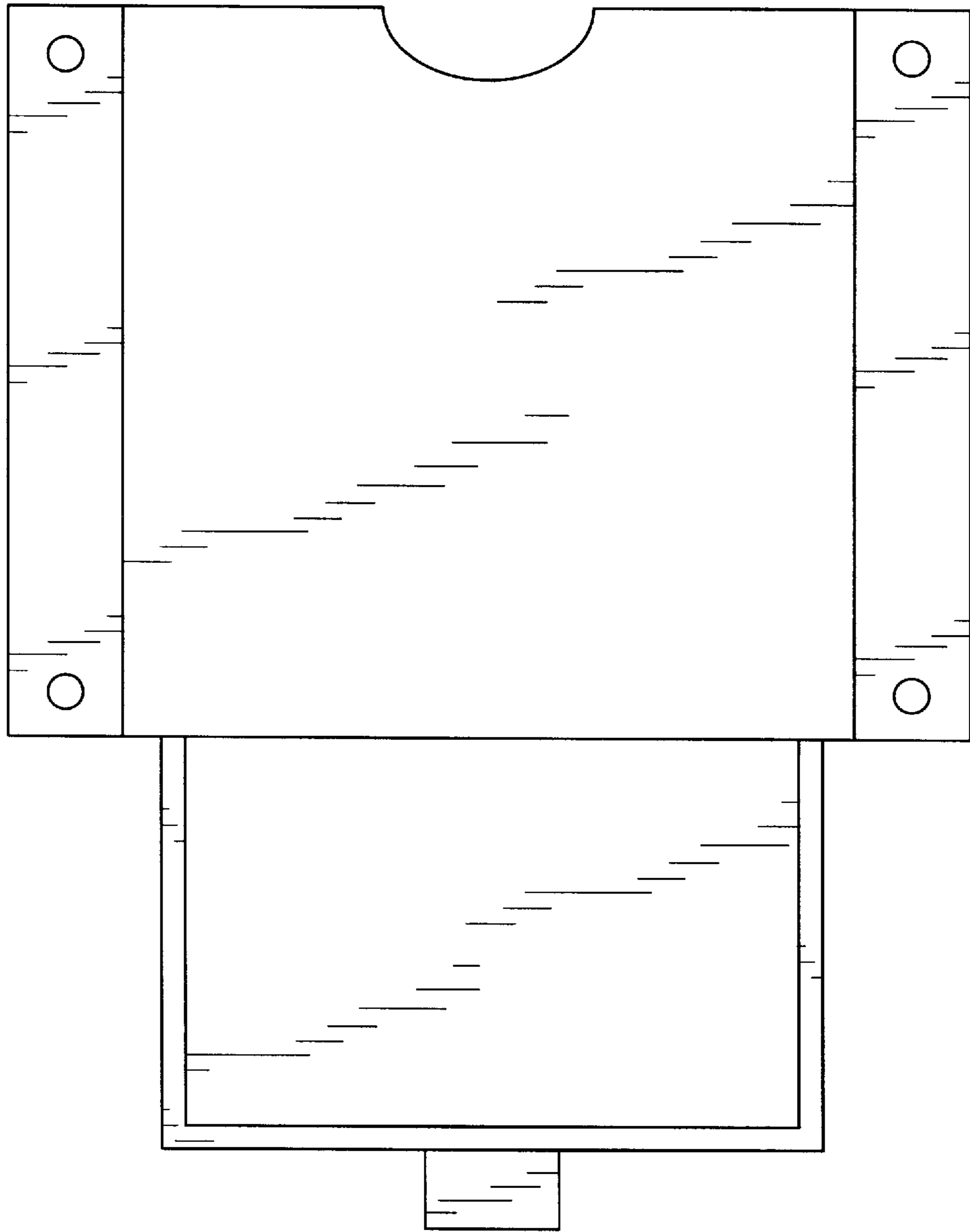

Fig. 6

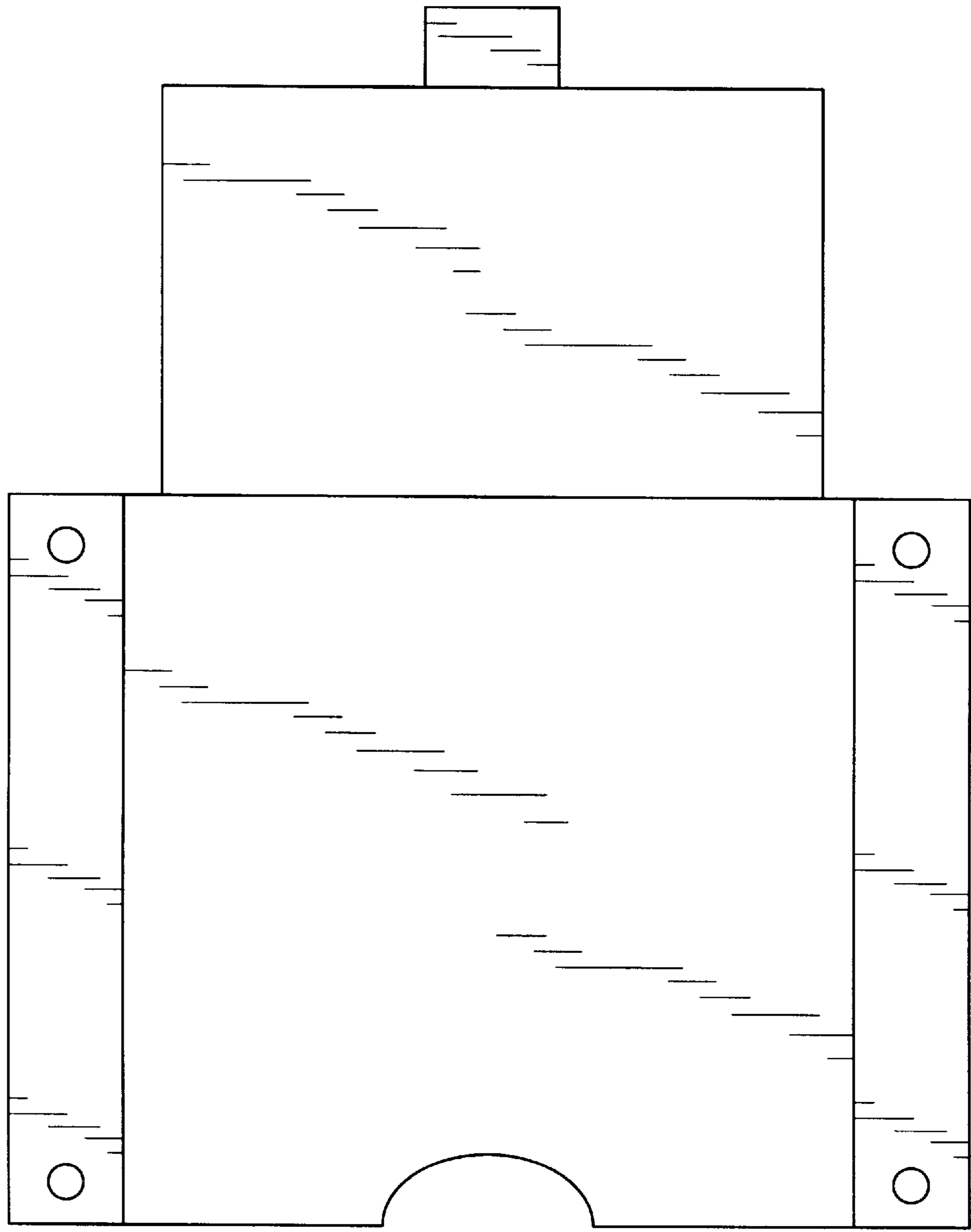

Fig. 7

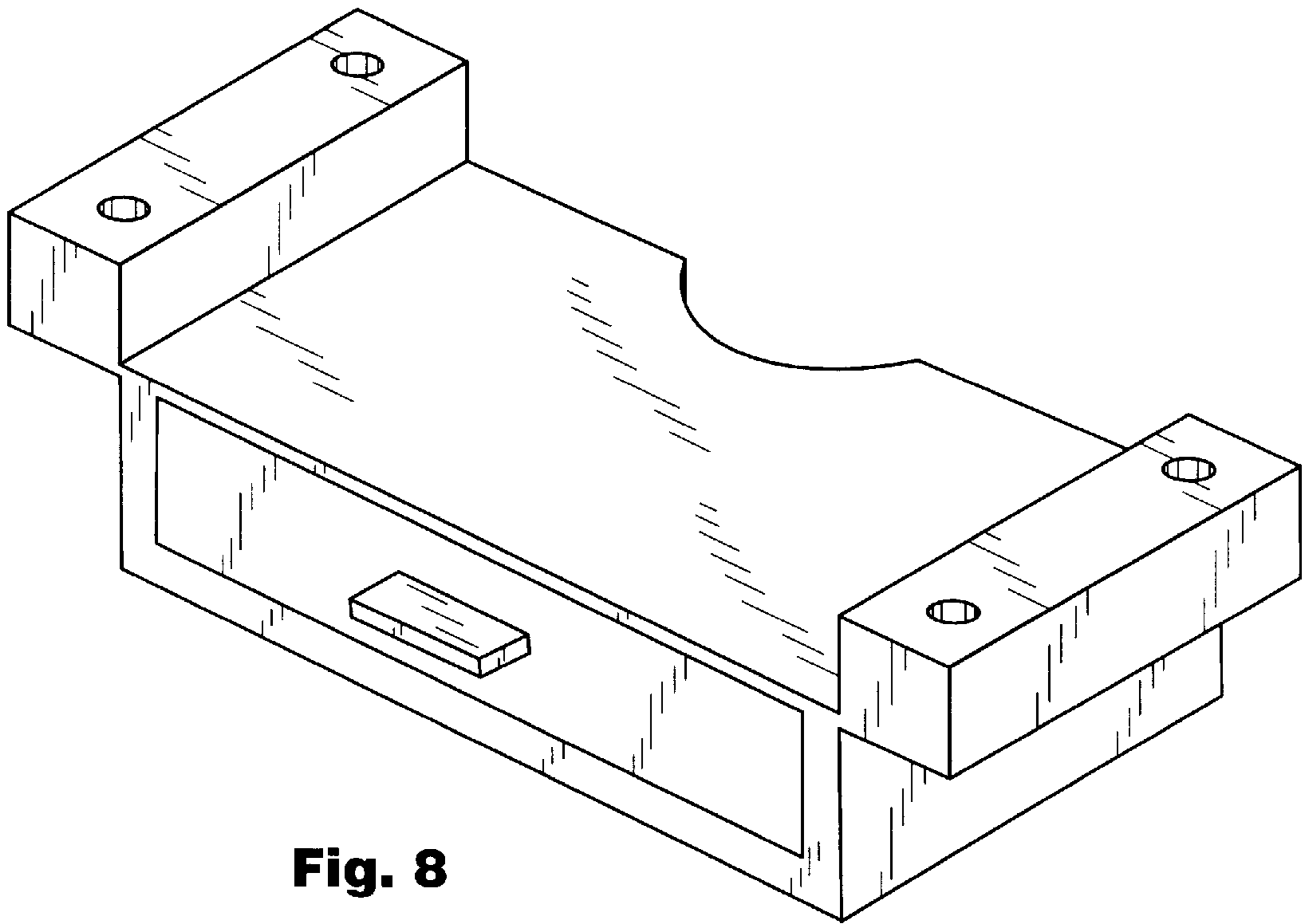

Fig. 8