



US00D400211S

# United States Patent [19]

[11] **Patent Number: Des. 400,211**

**Thallemer et al.**

[45] **Date of Patent: \*\*Oct. 27, 1998**

[54] **LUBRICATOR UNIT**

OTHER PUBLICATIONS

[75] Inventors: **Axel Thallemer; Jan Kleffmann**, both of Esslingen, Germany

Pneumatic Filters, Regulators, Lubricators and Pre-Assembled Air Service Mod Festo Corporation Catalog, pp. 1, 3-5, 18 and 29-30; 1990.

[73] Assignee: **Festo AG & Co.**, Esslingen, Germany

Pneumatic Filters, Regulators, Lubricators, Economical, High-Flow "D-Series", Festo Corporation Catalog, pp. 1-14, 6-8 and 18-20; 1996.

[\*\*] Term: **14 Years**

*Primary Examiner*—Ralf Seifert  
*Attorney, Agent, or Firm*—Hoffmann & Baron, LLP

[21] Appl. No.: **77,490**

[22] Filed: **Oct. 2, 1997**

[57] **CLAIM**

[30] **Foreign Application Priority Data**

The ornamental design of a lubricator unit, as shown and described.

Apr. 8, 1997 [WO] WIPO ..... DM/039796

[51] **LOC (6) Cl.** ..... **15-02**

**DESCRIPTION**

[52] **U.S. Cl.** ..... **D15/7**

[58] **Field of Search** ..... D15/7; 220/3, 220/82 R, 461; 210/313; 184/55 A; 55/219, 274, 275; 137/195, 416, 418; 251/65; 417/423.5; 96/135

FIG. 1 is a front perspective view of a lubricator unit showing our new design;  
FIG. 2 is a front elevational view thereof;  
FIG. 3 is a back elevational view thereof opposite to that shown in FIG. 2;  
FIG. 4 is a side elevational view thereof;  
FIG. 5 is a side elevational view thereof opposite that shown in FIG. 4;  
FIG. 6 is a top plan view thereof; and,  
FIG. 7 is a bottom plan view thereof.

[56] **References Cited**

**U.S. PATENT DOCUMENTS**

D. 380,217 6/1997 Jermeay et al. .... D15/5  
3,980,457 9/1976 Smith ..... 55/219  
4,234,014 11/1980 Knight .  
4,464,186 8/1984 Mann ..... 96/135

**1 Claim, 6 Drawing Sheets**

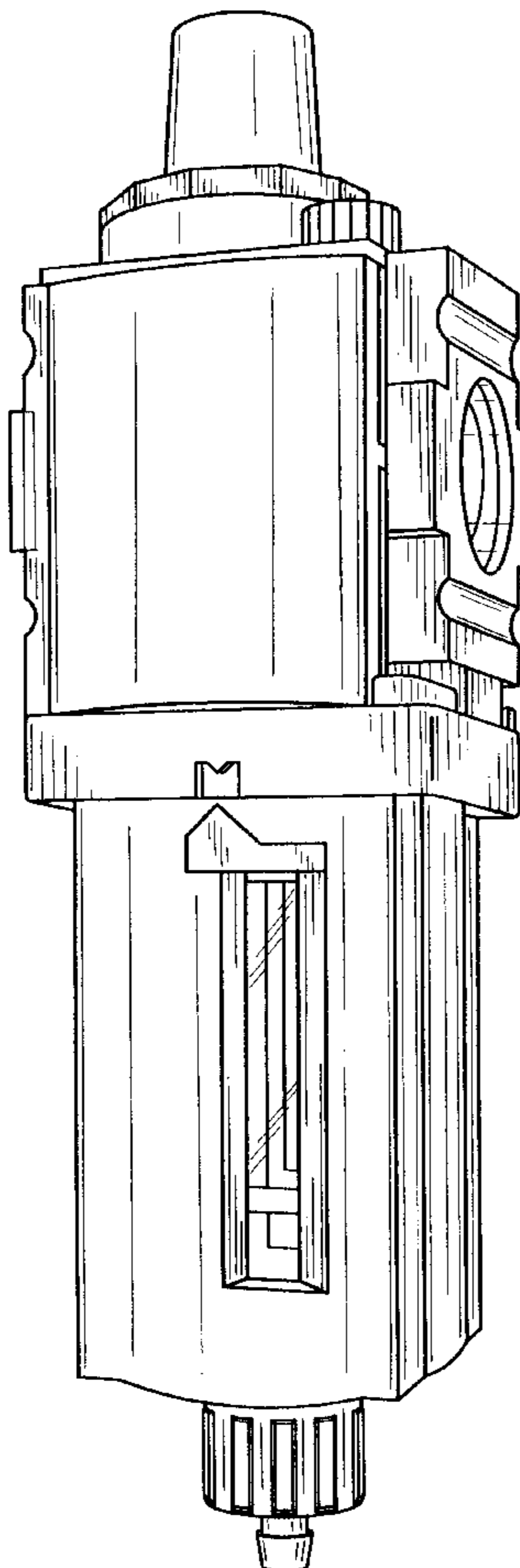

FIG-1

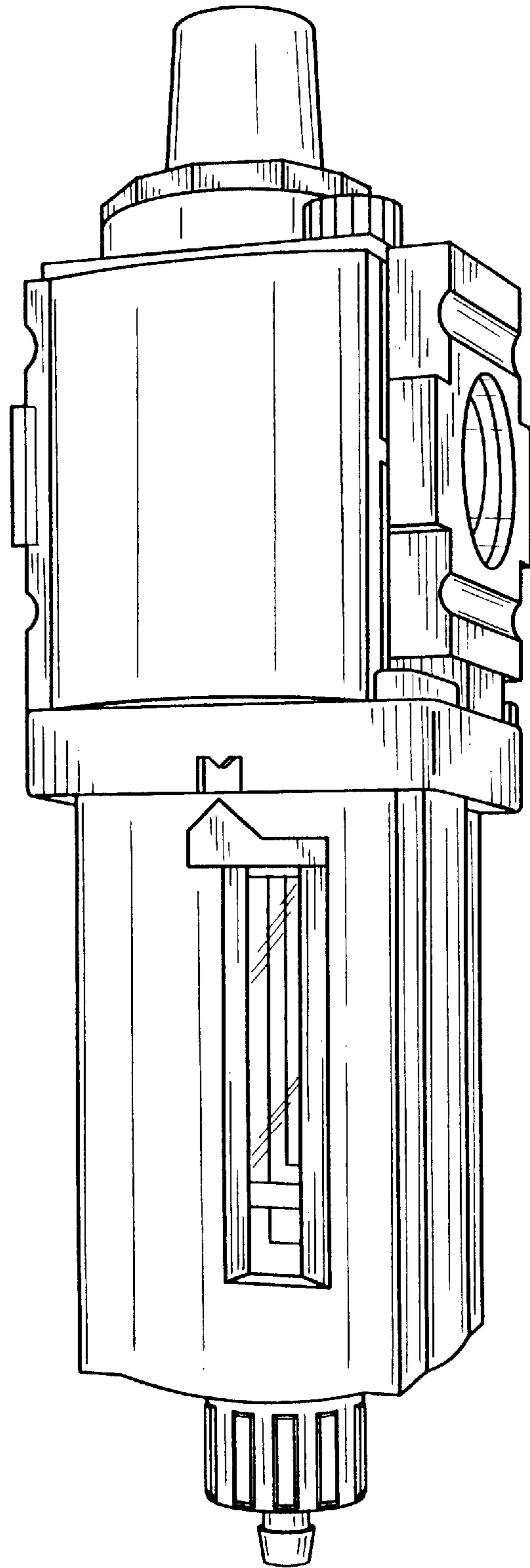

FIG-2

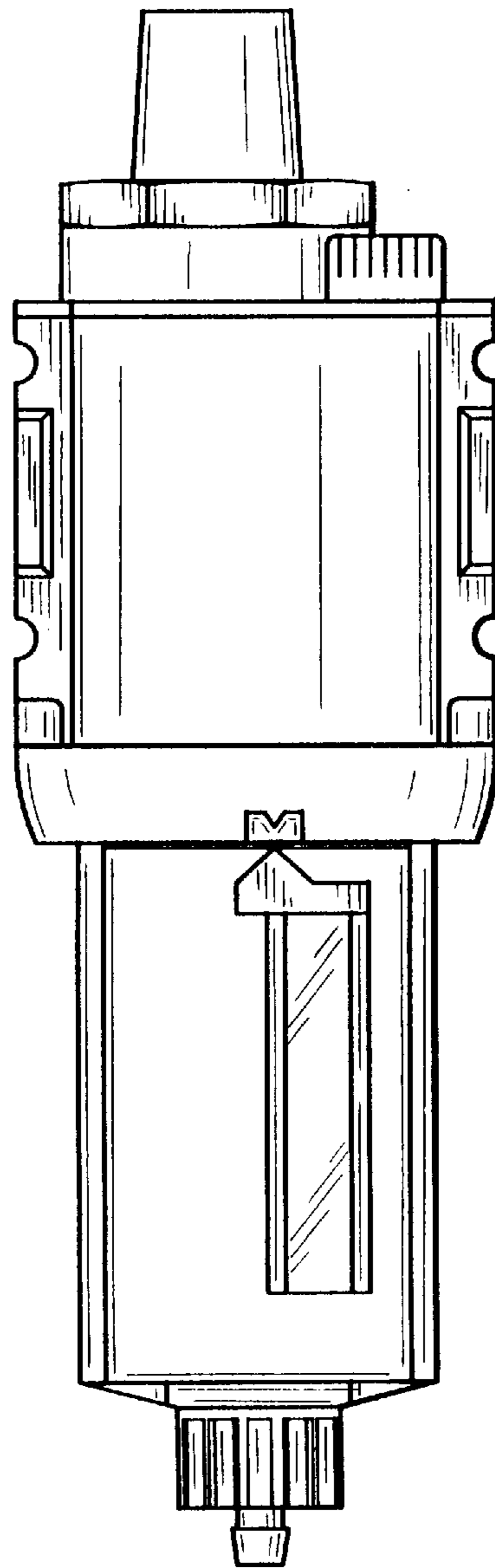

FIG-3

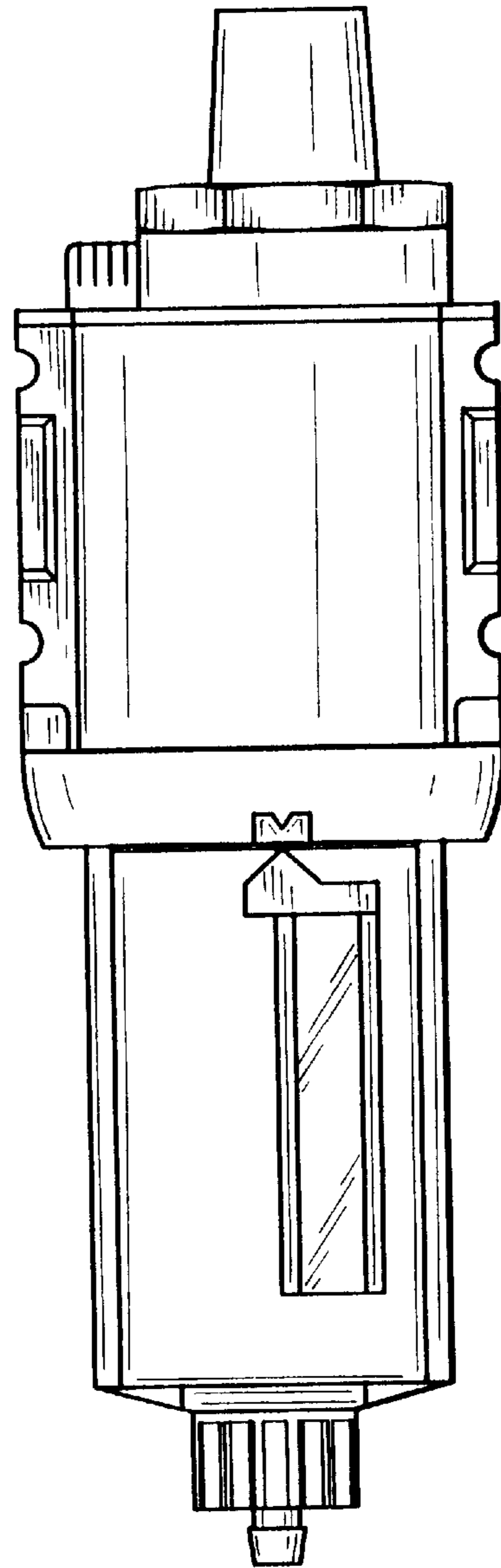

FIG-4

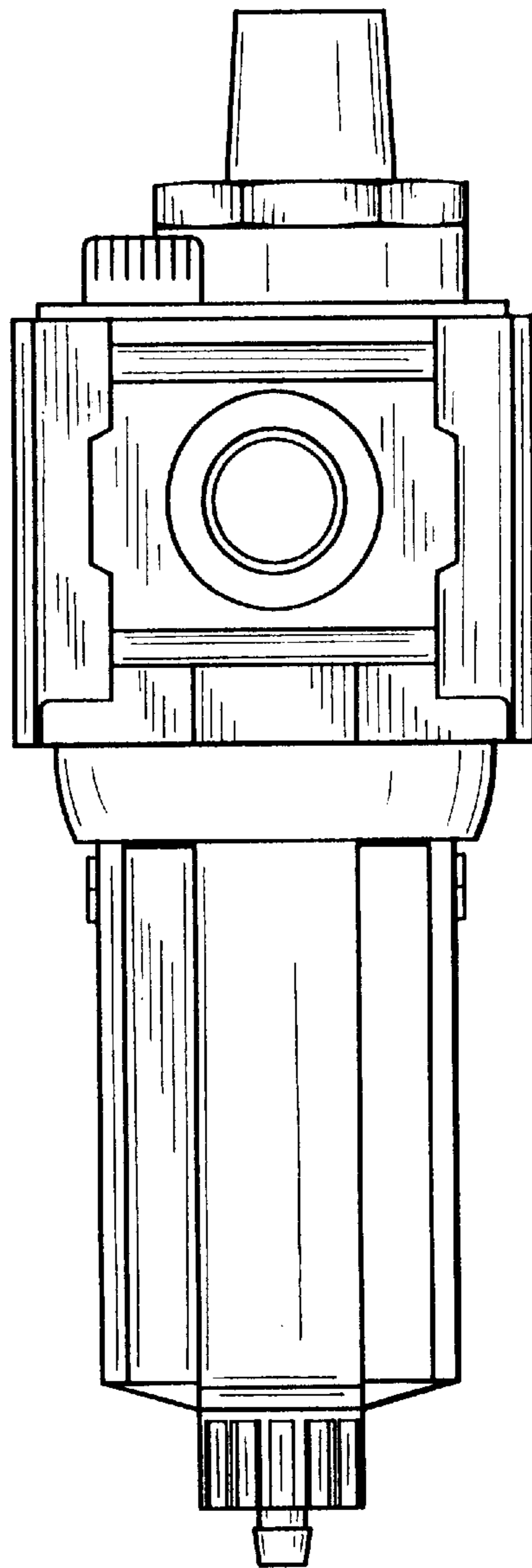

FIG-5

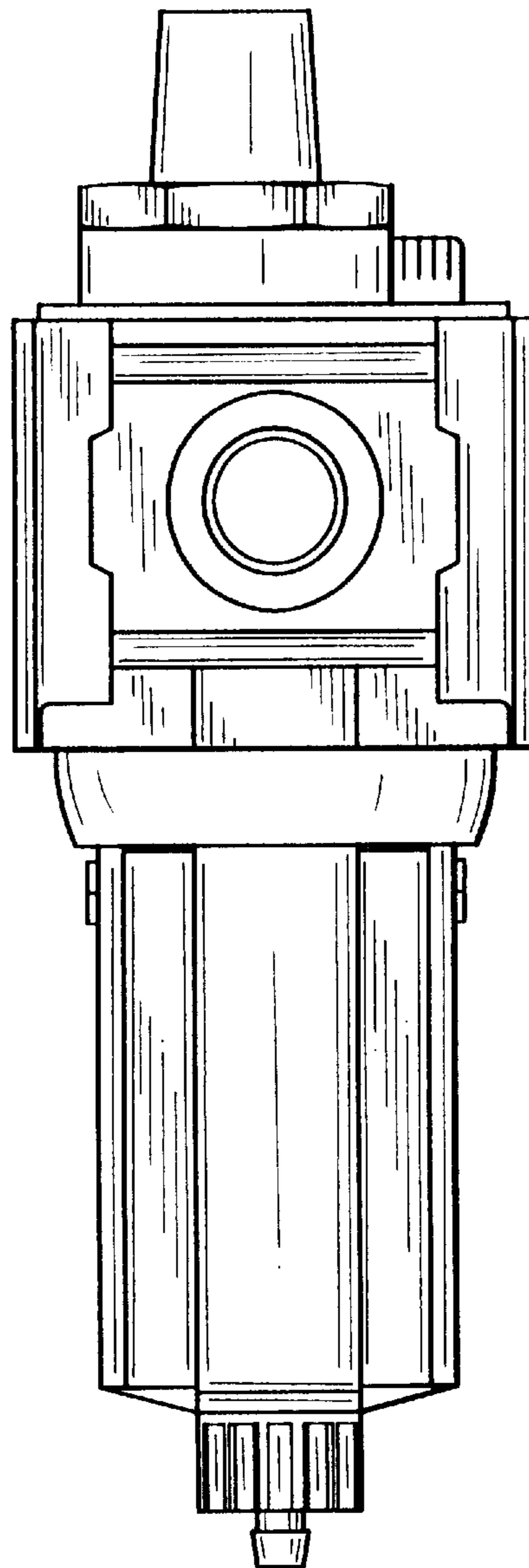

FIG-6

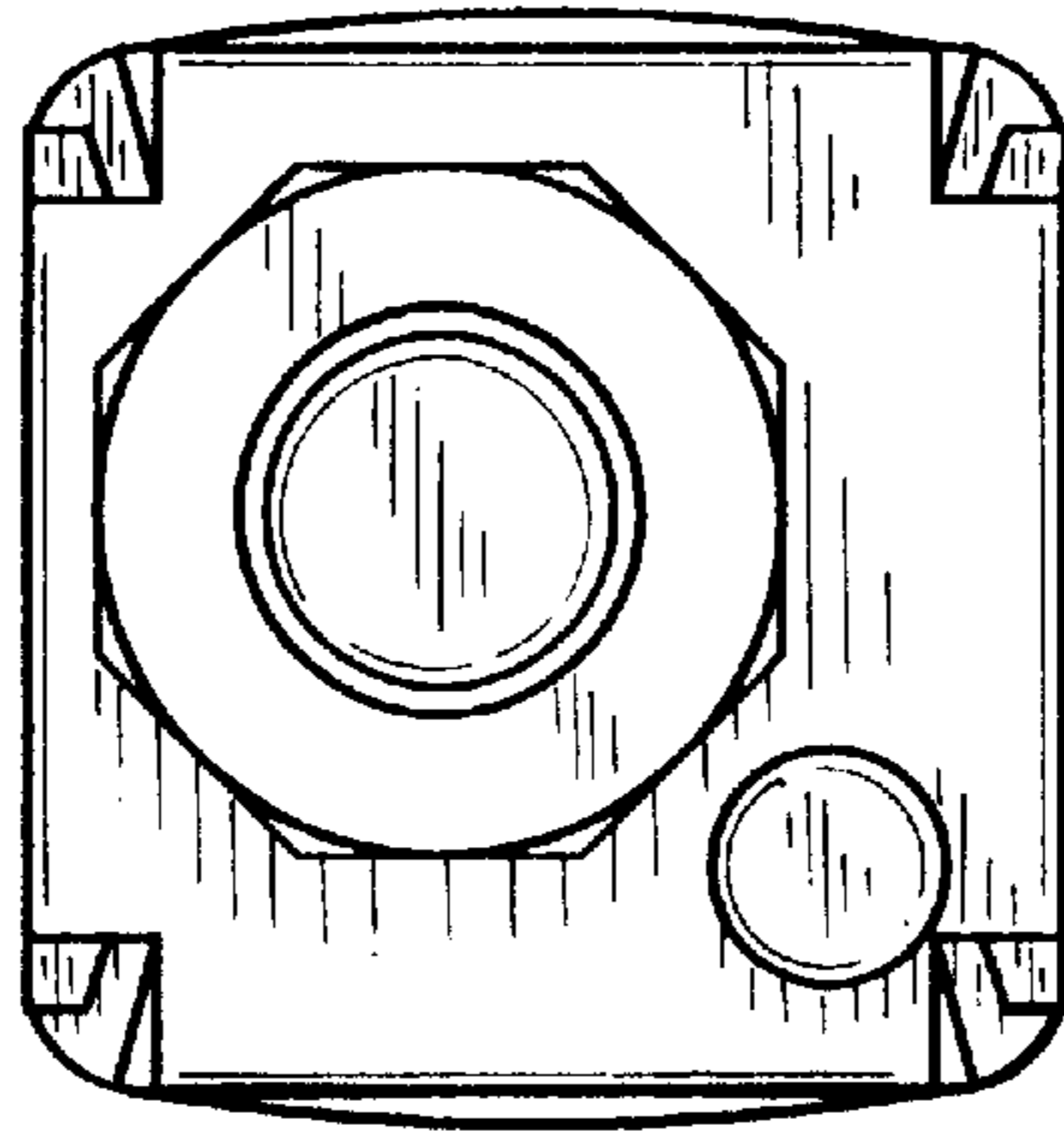

FIG-7

