



US00D400184S

# United States Patent [19]

Meiller et al.

[11] **Patent Number: Des. 400,184**

[45] **Date of Patent: \*\*Oct. 27, 1998**

[54] **SWITCH MODULE FOR MOTORCAR SEAT ADJUSTING**

[75] Inventors: **Hermann Meiller; Martin Hegen**, both of Amberg; **Raymond Carter**, Newbury Park, all of Calif.

[73] Assignee: **Grammer AG**, Amberg, Germany

[\*\*] Term: **14 Years**

[21] Appl. No.: **64,233**

[22] Filed: **Dec. 24, 1996**

[30] **Foreign Application Priority Data**

Jun. 29, 1996 [DE] Germany ..... M9605741.6

[51] **LOC (6) Cl. .... 13-03**

[52] **U.S. Cl. .... D13/171**

[58] **Field of Search** ..... D13/158, 162, D13/164, 171, 184; D12/415, 416, 190; 296/70; 180/315, 326; 200/5 R, 5 A, 520, 553, 308

[56] **References Cited**

**U.S. PATENT DOCUMENTS**

D. 301,873 6/1989 Gutman ..... D13/171

D. 310,202 8/1990 Suck ..... D13/171  
D. 385,847 11/1997 Ma et al. .... D12/415  
4,701,629 10/1987 Citroen ..... 180/315 X  
5,332,877 7/1994 Oura et al. .... 200/308

*Primary Examiner*—Brian N. Vinson  
*Attorney, Agent, or Firm*—Jones, Tullar & Cooper, P.C.

[57] **CLAIM**

The ornamental design for a switch module for motorcar seat adjusting, as shown and described.

**DESCRIPTION**

FIG. 1 is a plan view of the switch module design according to the present invention;

FIG. 2 is a right side perspective view of the switch module design of FIG. 1;

FIG. 3 is a further right side perspective view of the switch module design of FIG. 1;

FIG. 4 is an enlarged plan view showing the controls; and, FIG. 5 is an elevation view of the switch module design.

**1 Claim, 3 Drawing Sheets**

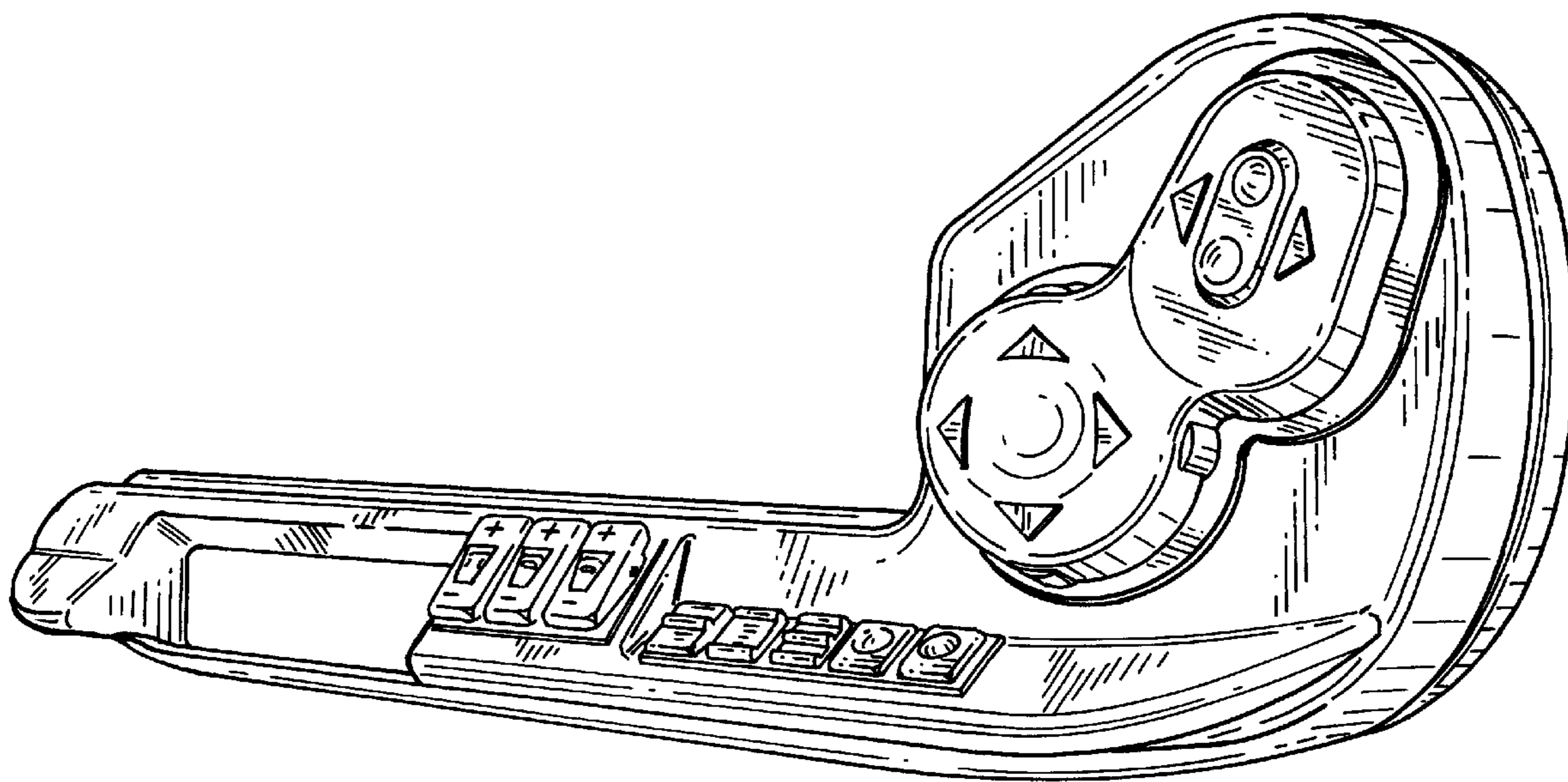

FIG. 1

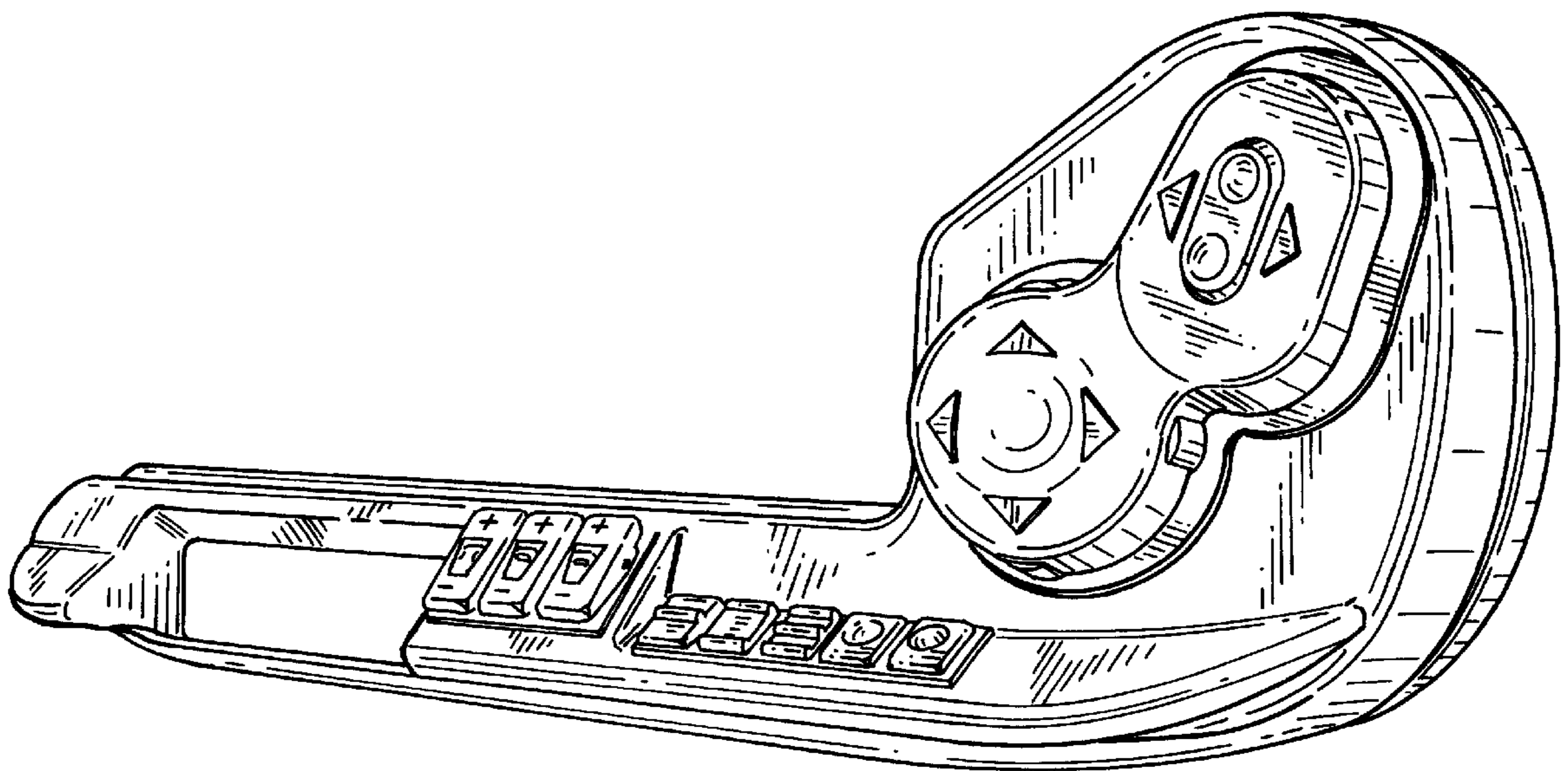
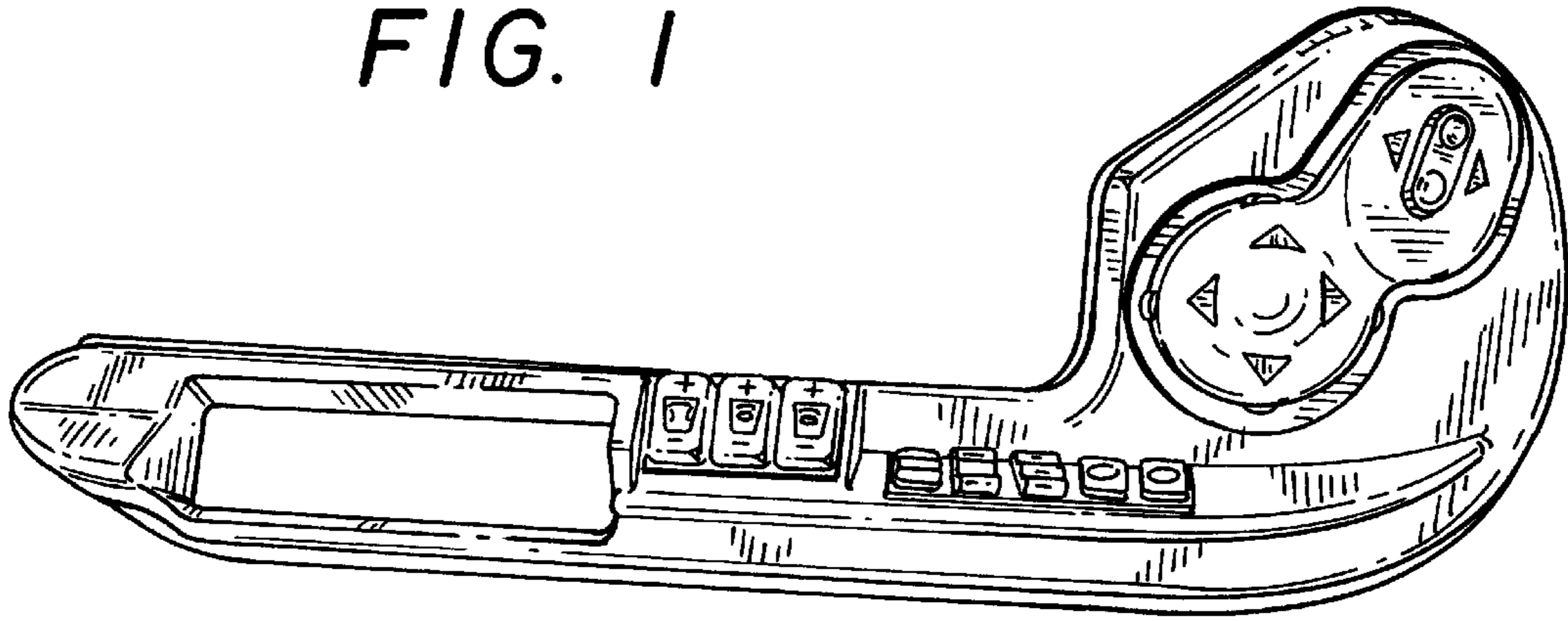

FIG. 2

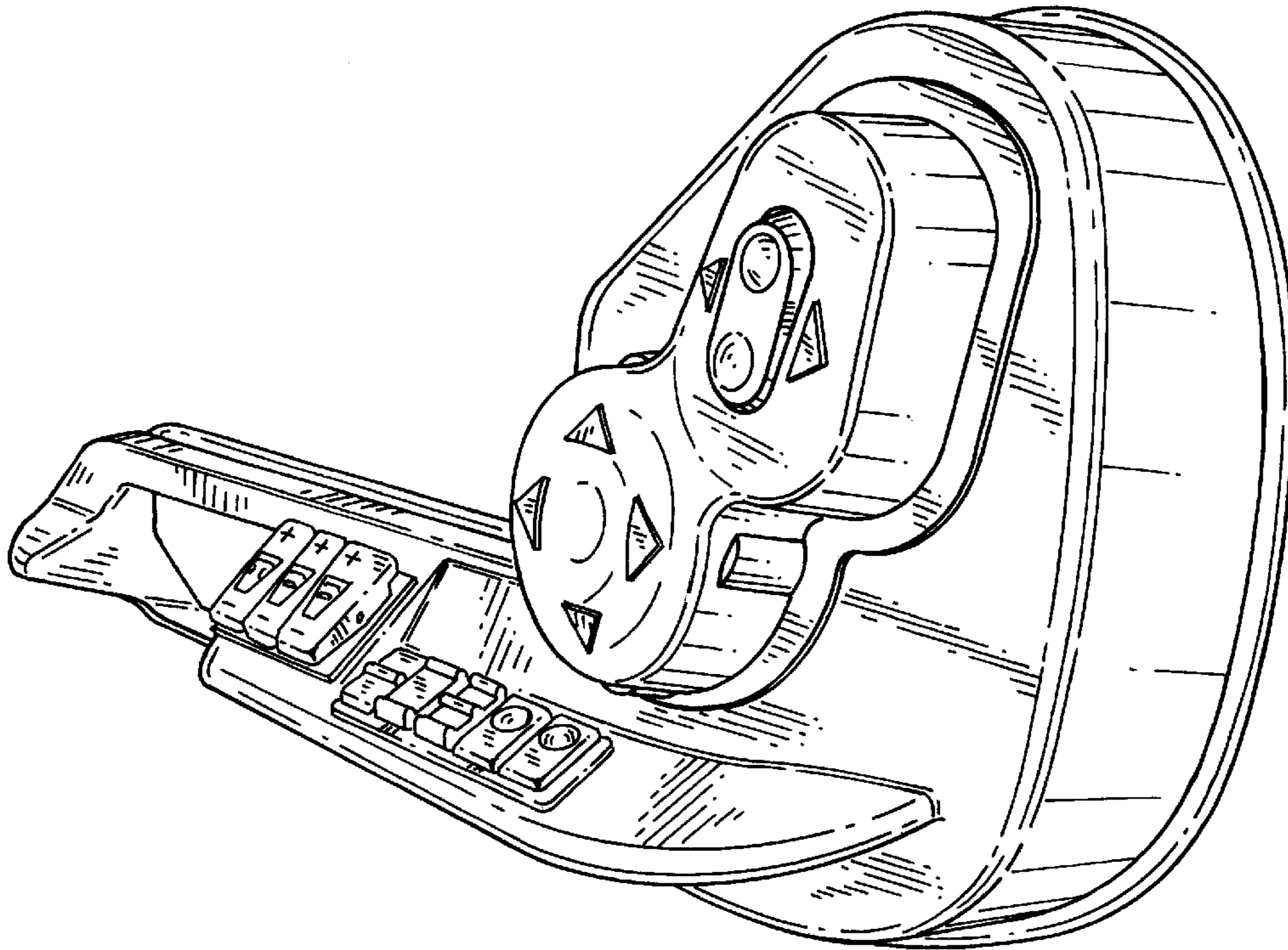

FIG. 3

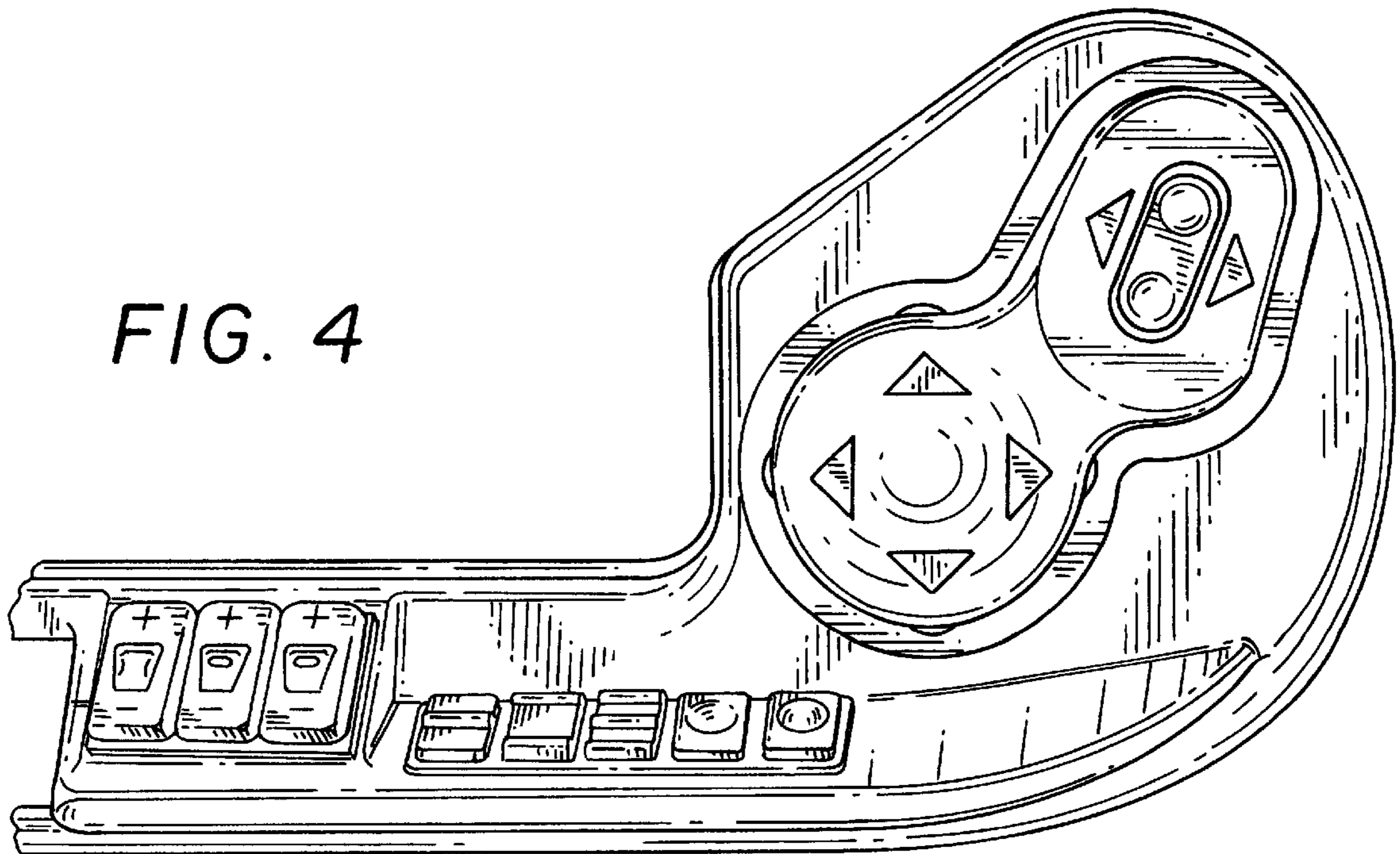

FIG. 4



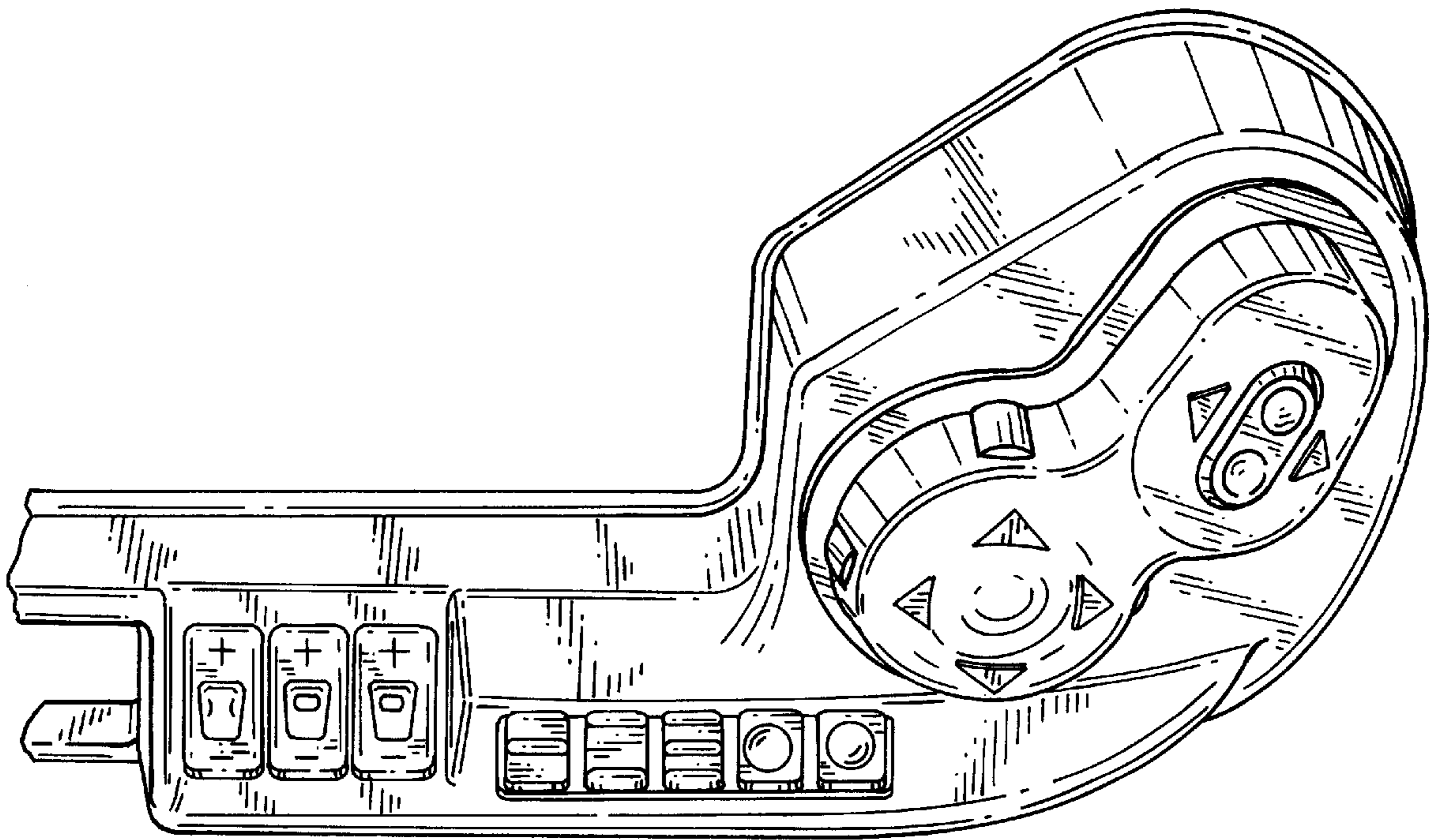

FIG. 5