



US00D400157S

United States Patent [19]

Fiorentino et al.

[11] Patent Number: **Des. 400,157**

[45] Date of Patent: ****Oct. 27, 1998**

[54] PATCH AND SWIVEL FOR A DRIFT CONTROL PARACHUTE FOR A BOAT

Attorney, Agent, or Firm—Morland C. Fischer

[76] Inventors: **Jenero Fiorentino**, 2148 Paseo del Mar, San Pedro, Calif. 90732;
Kimberly A. Hadash, 383 Monte Vista Ave., #C, Newport Beach, Calif. 92627

[57] CLAIM

The ornamental design for a patch and swivel for a drift control parachute for a boat, as shown and described.

[**] Term: **14 Years**

DESCRIPTION

[21] Appl. No.: **65,761**

FIG. 1 is a side elevational view showing a patch and swivel for a drift control parachute which forms our new design, the boat, parachute and tether lines which are shown in phantom being for illustrative purposes only and forming no part of our design;

[22] Filed: **Jun. 13, 1997**

[51] LOC (6) Cl. **12-07**

[52] U.S. Cl. **D12/321**

[58] Field of Search D12/319, 323,
D12/321, 345; 244/31, 32, 33; D21/84;
441/23, 30

FIG. 2 is an enlarged right side elevational view of the patch and swivel affixed to the drift control parachute of FIG. 1, this side and the opposite left side elevational views being of identical design;

[56] References Cited

U.S. PATENT DOCUMENTS

5,115,998 5/1992 Olive 244/31

FIG. 3 is a top plan view thereof;

OTHER PUBLICATIONS

Janes all the world's aircraft, 1995-96, p. 678, DKBADP-800 passenger/cargo airship.

FIG. 4 is a front elevational view thereof, this view and the opposite rear elevational view being of identical design; and,

FIG. 5 is a bottom plan view thereof.

Primary Examiner—Kay H. Chin

1 Claim, 3 Drawing Sheets

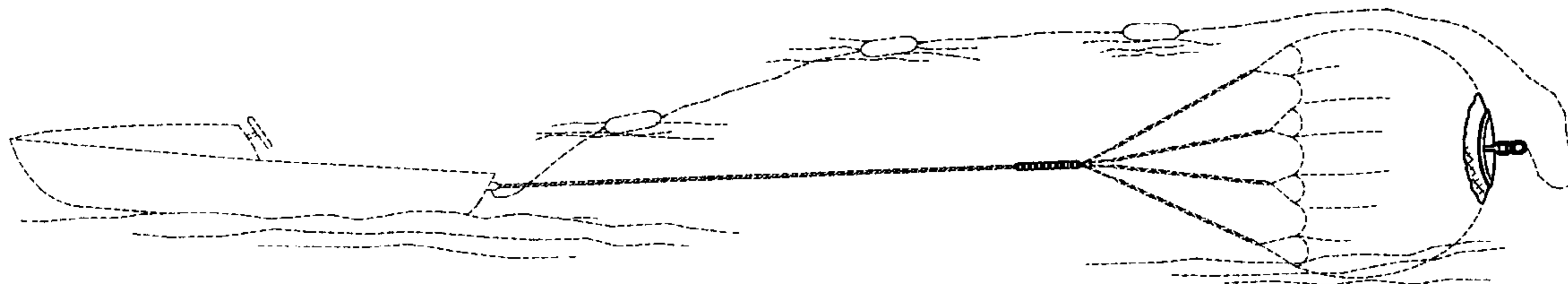

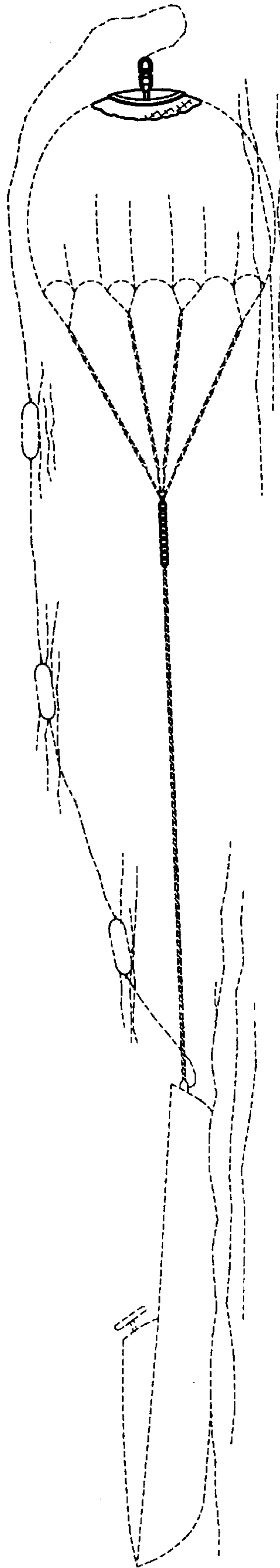

Fig. 1

Fig. 2

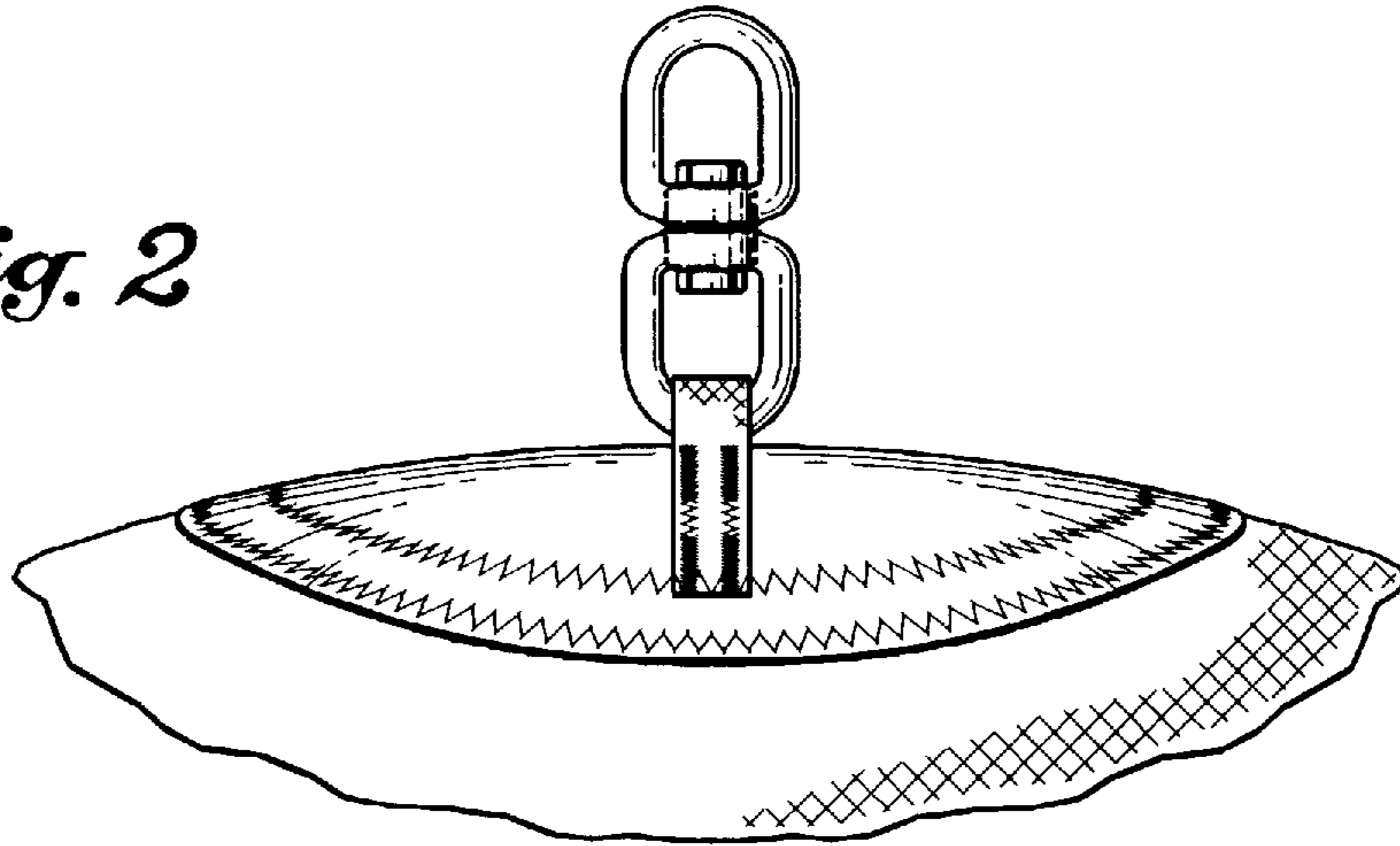

Fig. 3

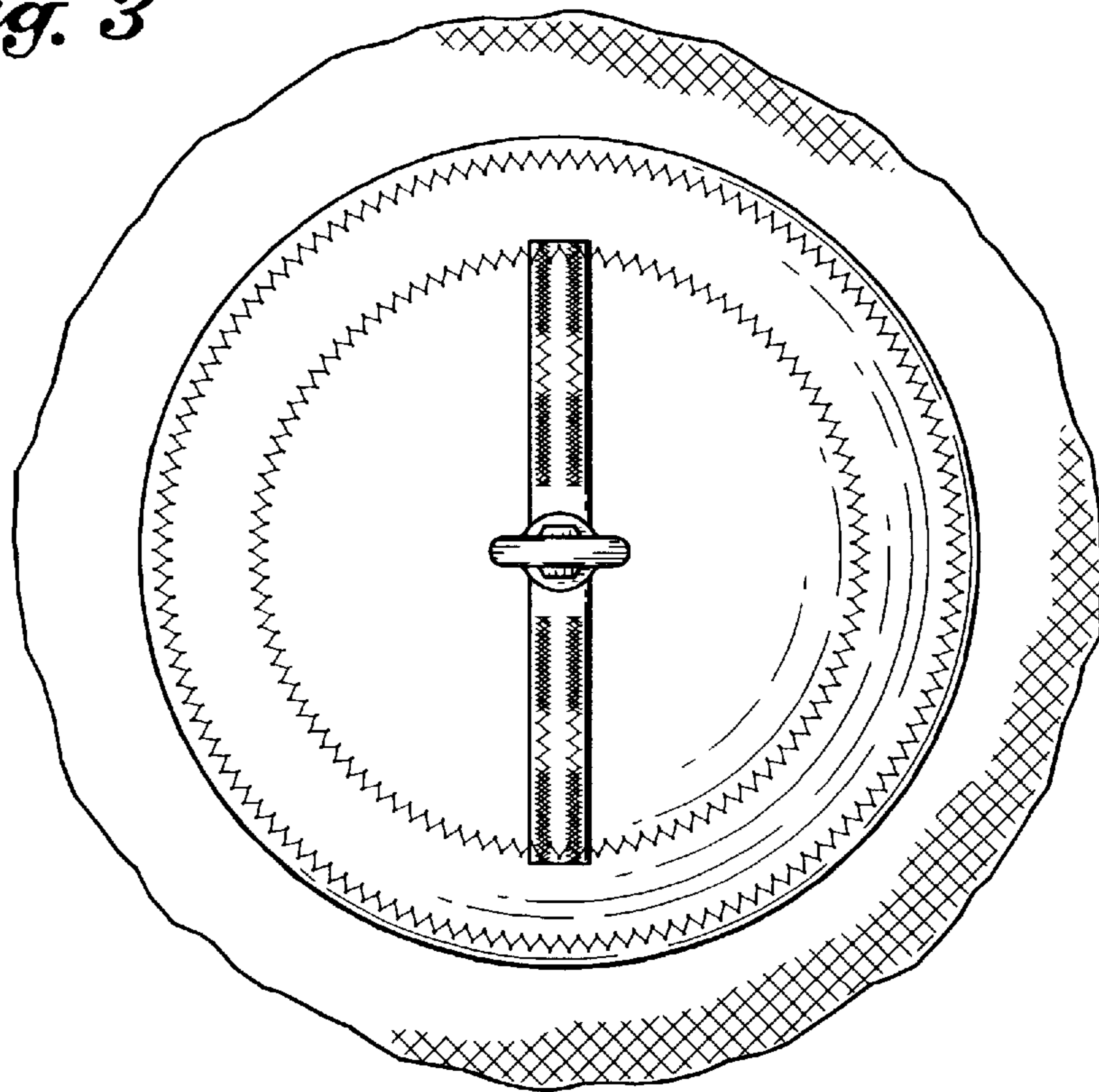

Fig. 4

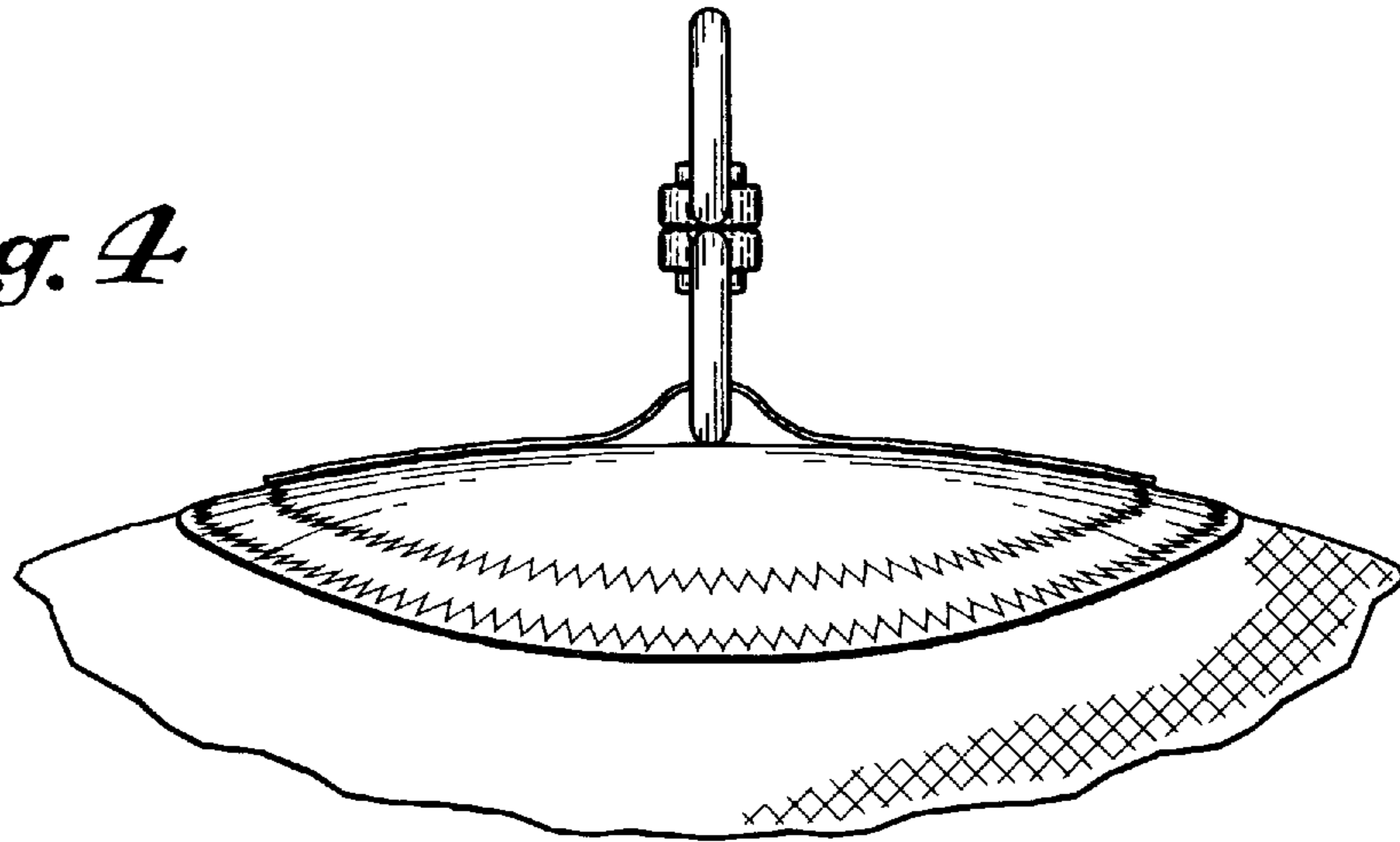

Fig. 5

