



US00D400152S

**United States Patent** [19]  
**Zentner**

[11] **Patent Number: Des. 400,152**

[45] **Date of Patent: \*\*Oct. 27, 1998**

[54] **PICKUP TRUCK RUNNING BOARD**

D. 361,973 9/1995 Hornik ..... D12/203

[75] Inventor: **Edward Zentner**, Clarkston, Mich.

**OTHER PUBLICATIONS**

[73] Assignee: **Durakon Industries, Inc.**, Lapeer, Mich.

J.C Whitney Catalog #578J, See "Custom-fit Cab-Length Running Boards With Built-In Step", p. 111. Aug. 1995.

[\*\*] Term: **14 Years**

*Primary Examiner*—James Gandy  
*Assistant Examiner*—Stacia Sinuik  
*Attorney, Agent, or Firm*—Brinks Hofer Gilson & Lione

[21] Appl. No.: **79,858**

[22] Filed: **Nov. 24, 1997**

[57] **CLAIM**

[51] **LOC (6) Cl.** ..... **12-16**

[52] **U.S. Cl.** ..... **D12/203**

[58] **Field of Search** ..... D12/203, 190;  
280/163, 164.1, 53.5, 848

The ornamental design for a pickup truck running board, as shown and described.

**DESCRIPTION**

[56] **References Cited**

**U.S. PATENT DOCUMENTS**

- D. 257,250 10/1980 Stoltenberg et al. .... D12/203
- D. 292,904 11/1987 Bielby ..... D12/203
- D. 297,135 8/1988 Davenport ..... D12/203
- D. 330,536 10/1992 Holloway ..... D12/203
- D. 336,629 6/1993 Hinrichs et al. .... D12/203
- D. 340,905 11/1993 Orth, Sr. et al. .... D12/203
- D. 342,476 12/1993 Beckett ..... D12/203
- D. 349,679 8/1994 Waddington et al. .... D12/203
- D. 351,128 10/1994 Waddington et al. .... D12/203

FIG. 1 is a perspective view from above and in front of a pickup truck running board according to the present design; FIG. 2 is a perspective view from above and behind a pickup truck running board according to the present design; and, FIG. 3 is an enlarged bottom, plan view of a pickup truck running board according to the present design.

Inasmuch as the rear aspects of a pickup truck running board according to the present design are not normally viewed, they are not illustrated and form no portion of the present design.

**1 Claim, 2 Drawing Sheets**

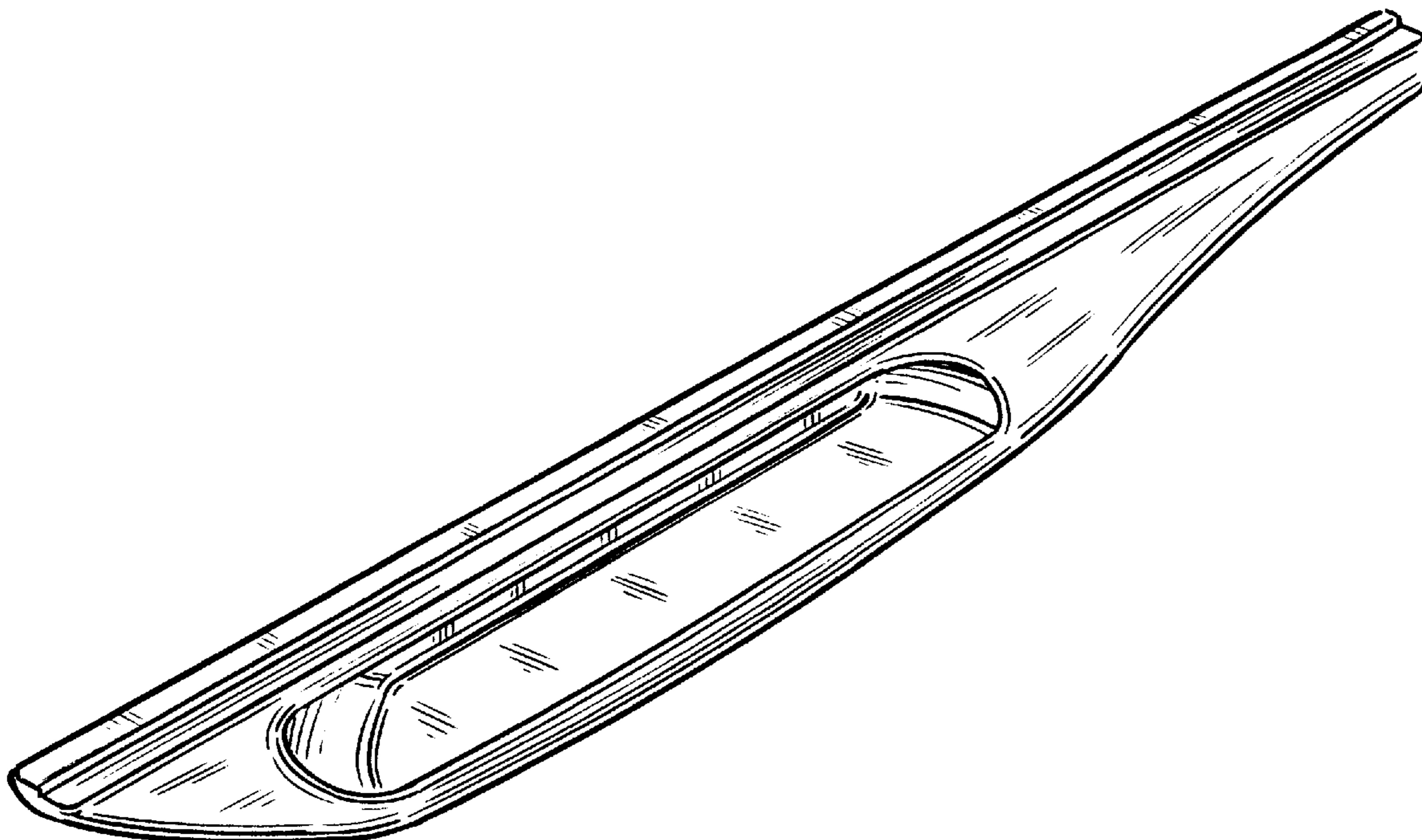

FIG. 1

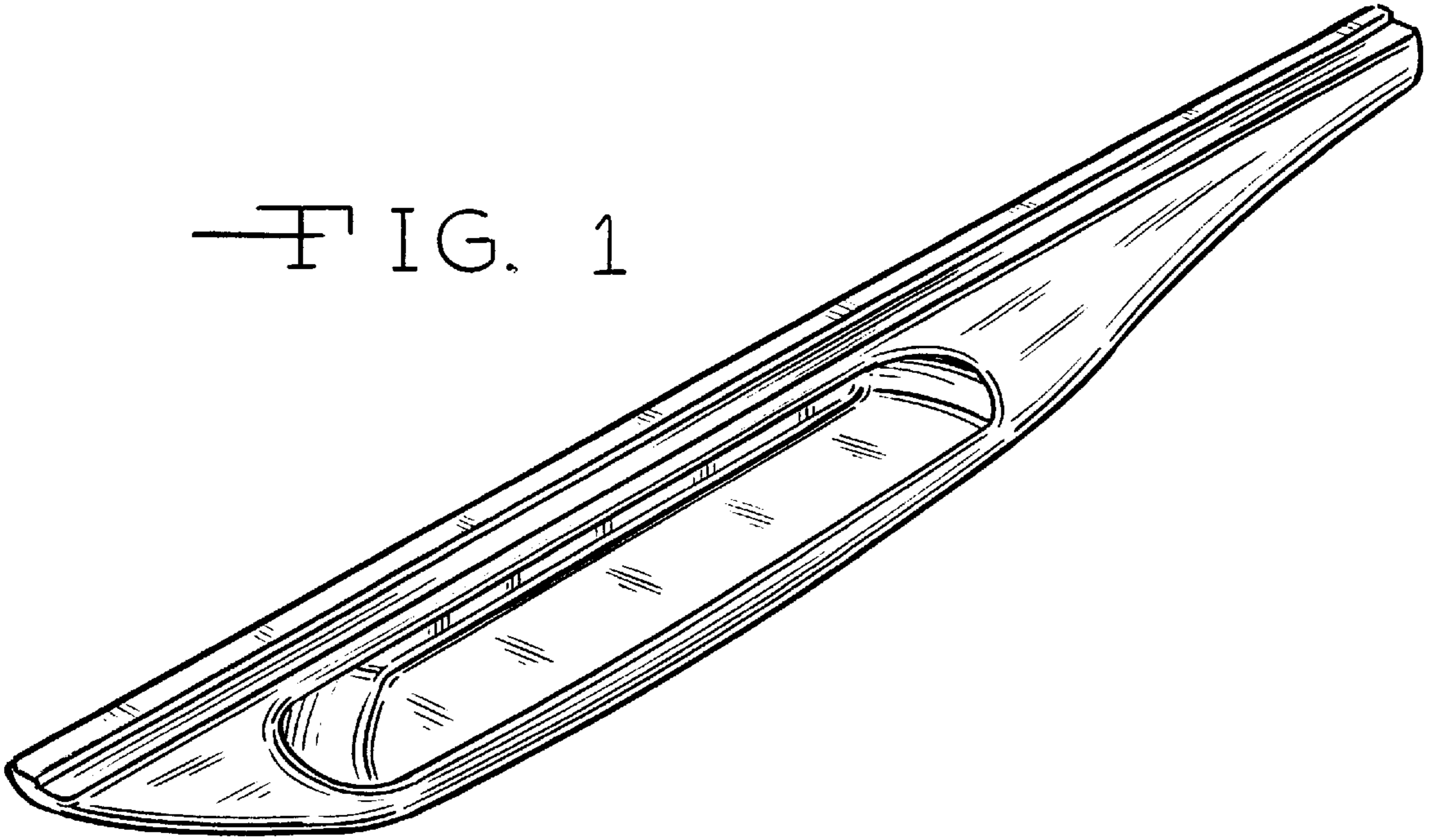
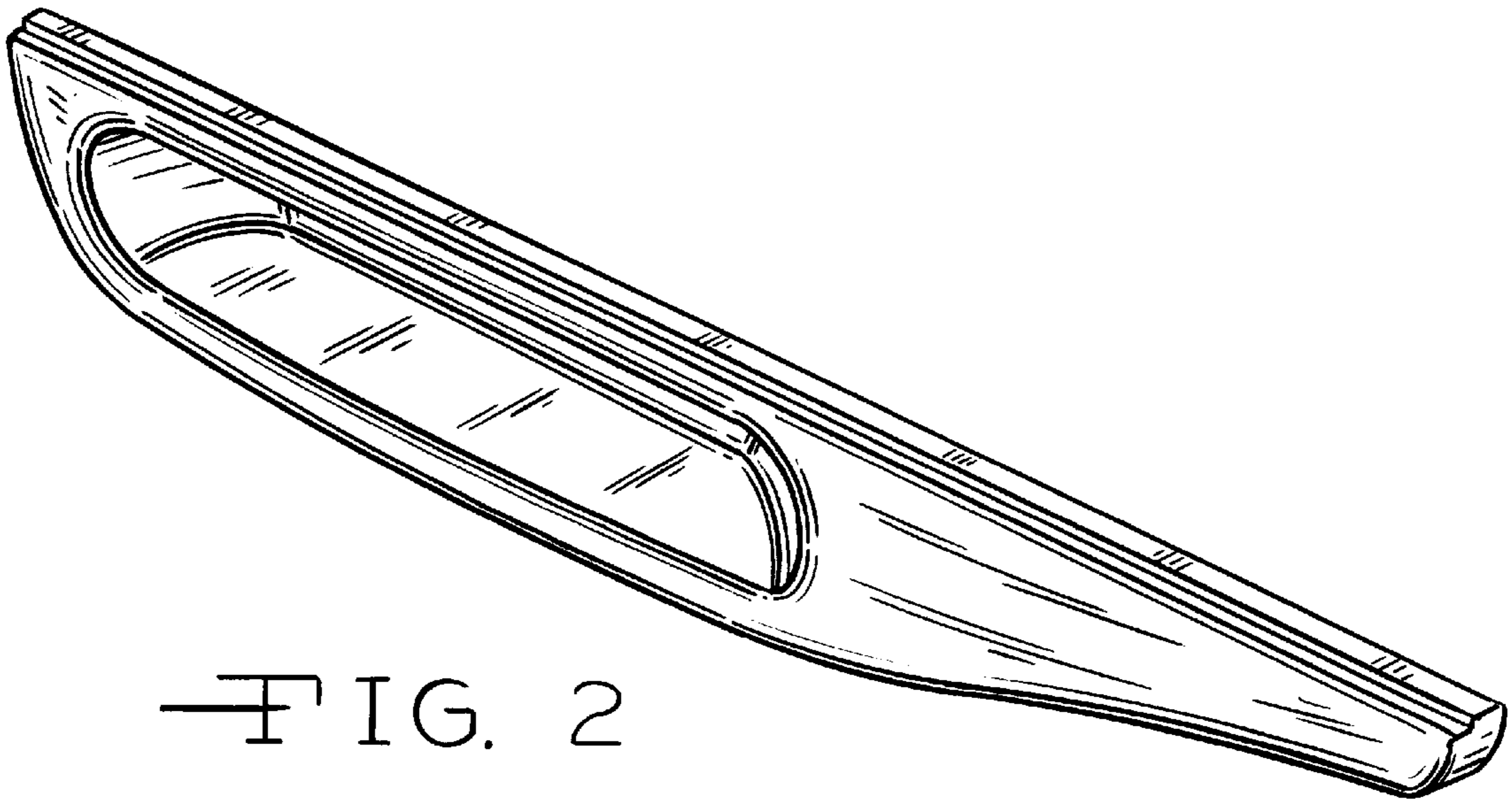

FIG. 2



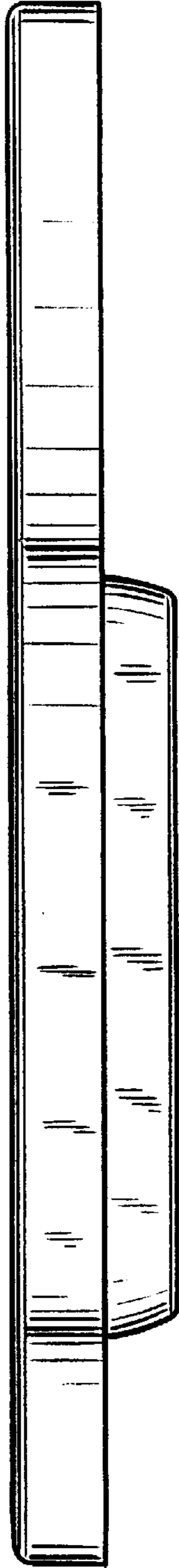

FIG. 3