



US00D400127S

United States Patent [19]

Golden et al.

[11] Patent Number: **Des. 400,127**

[45] Date of Patent: ****Oct. 27, 1998**

[54] **MOTORCYCLE FLUID LINE COVER**

[75] Inventors: **Earl F. Golden**, Milwaukee; **William G. Davidson**, Delafield, both of Wis.

[73] Assignee: **Harley-Davidson Motor Company**, Milwaukee, Wis.

[**] Term: **14 Years**

[21] Appl. No.: **76,806**

[22] Filed: **Sep. 18, 1997**

[51] **LOC (6) Cl.** **12-11**

[52] **U.S. Cl.** **D12/126**

[58] **Field of Search** D12/126, 114; 280/288.4; 180/219

[56] **References Cited**

U.S. PATENT DOCUMENTS

D. 294,921	3/1988	Nagy	D12/126
D. 294,922	3/1988	Nagy	D12/126
D. 345,127	3/1994	Stenylein et al.	D12/126
D. 346,773	5/1994	Sarver et al.	D12/126
D. 347,810	6/1994	Matthies	D12/126
D. 350,315	9/1994	Rudd et al.	D12/126

Primary Examiner—Melody N. Brown

Attorney, Agent, or Firm—Michael, Best & Friedrich LLP

[57] **CLAIM**

The ornamental design for a motorcycle fluid line cover, as shown.

DESCRIPTION

FIG. 1 is a top perspective view of a first embodiment of a motorcycle fluid line cover showing our new design; FIG. 2 is a top plan view thereof; FIG. 3 is a right end elevational view thereof; FIG. 4 is a left end elevational view thereof; FIG. 5 is a rear elevational view thereof; FIG. 6 is a front elevational view thereof; FIG. 7 is a top perspective view of a second embodiment of our new design; FIG. 8 is a top plan view of the second embodiment; FIG. 9 is a right end elevational view of the second embodiment; FIG. 10 is a left end elevational view of the second embodiment; FIG. 11 is a rear elevational view of the second embodiment; and, FIG. 12 is a front elevational view of the second embodiment.

The broken lines shown in all drawing views are for illustrative purposes only and form no part of the claimed design.

1 Claim, 4 Drawing Sheets

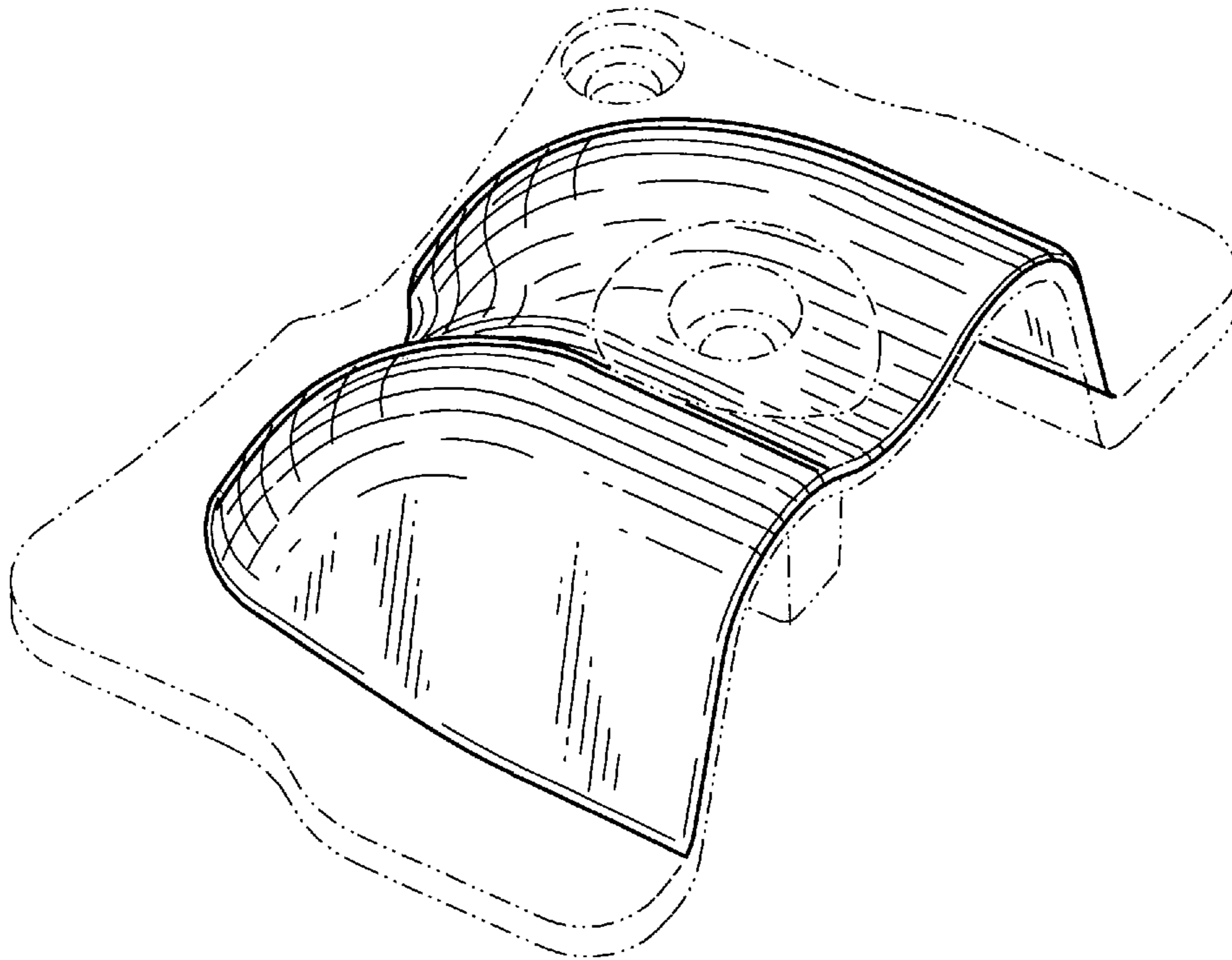

FIG. 1

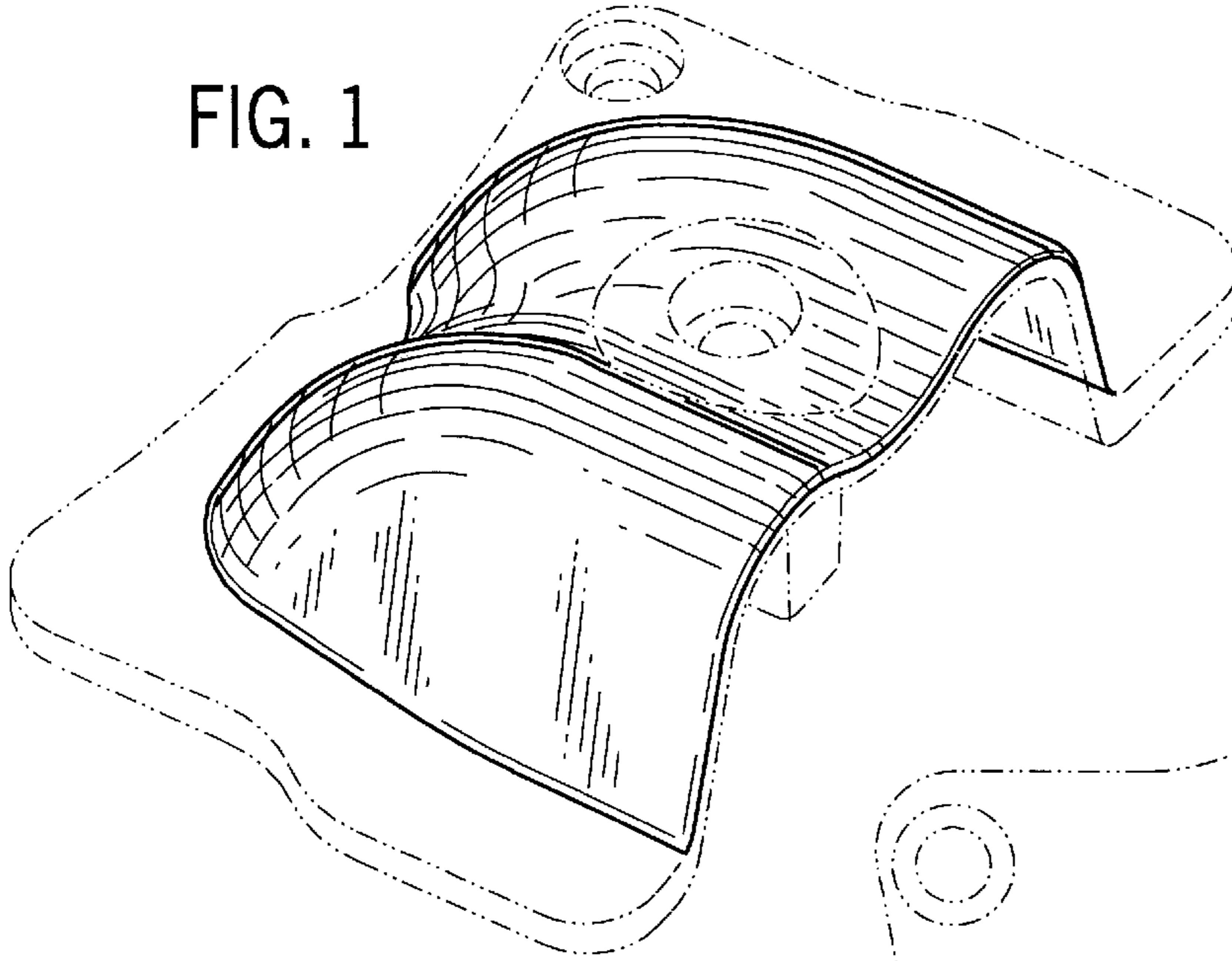

FIG. 2

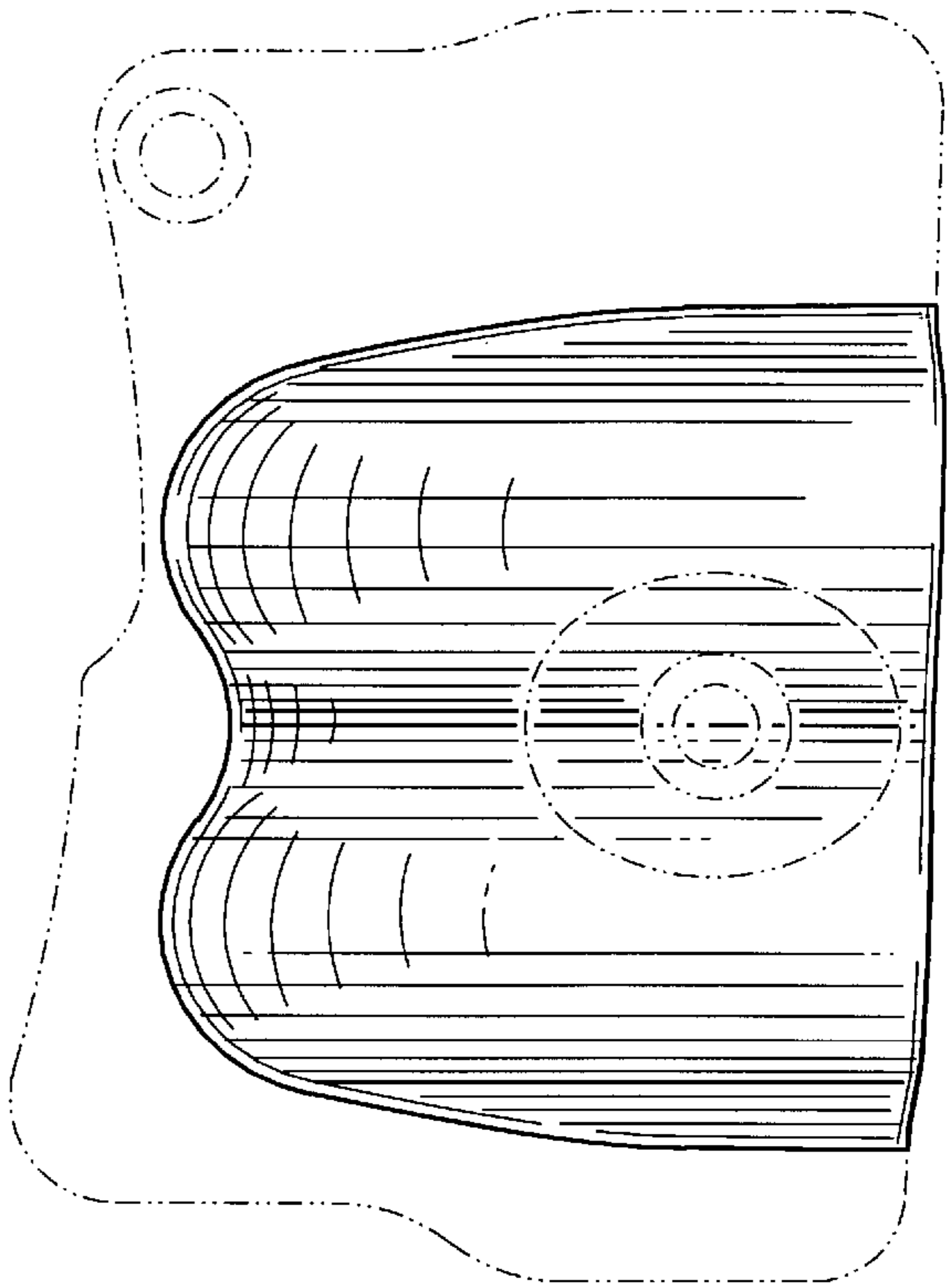

FIG. 3

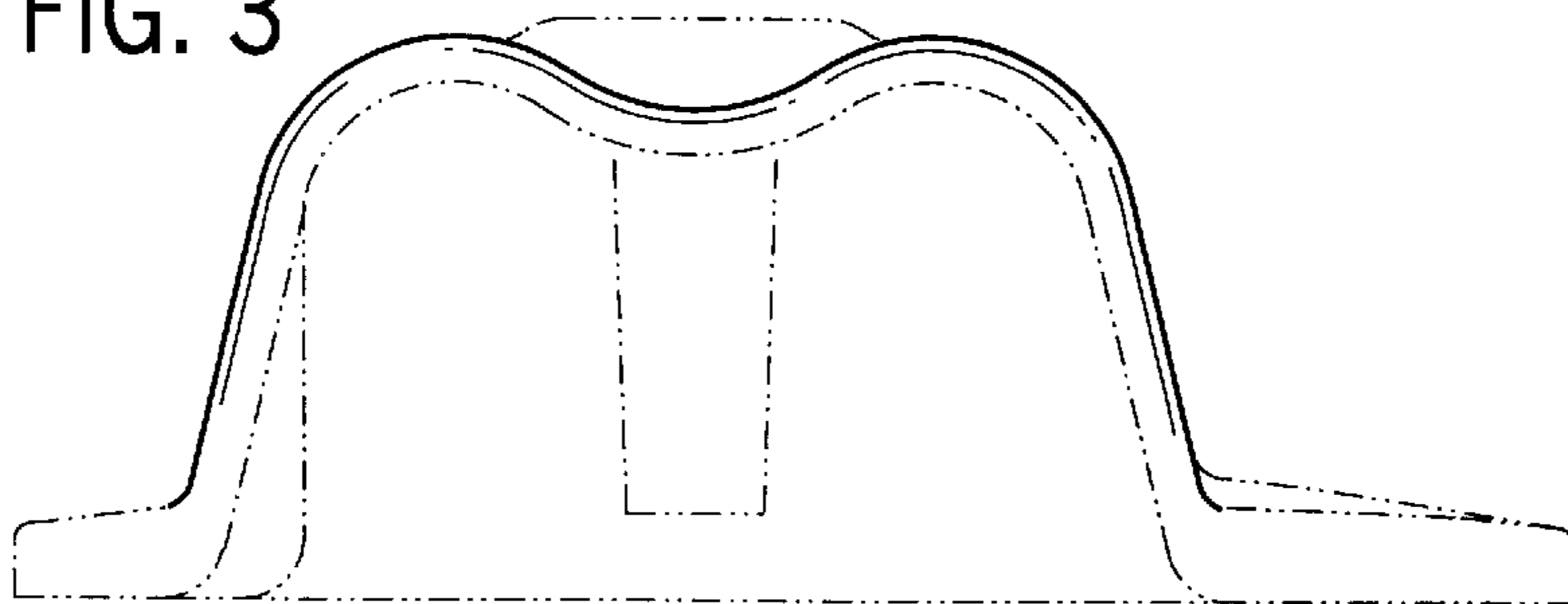

FIG. 4

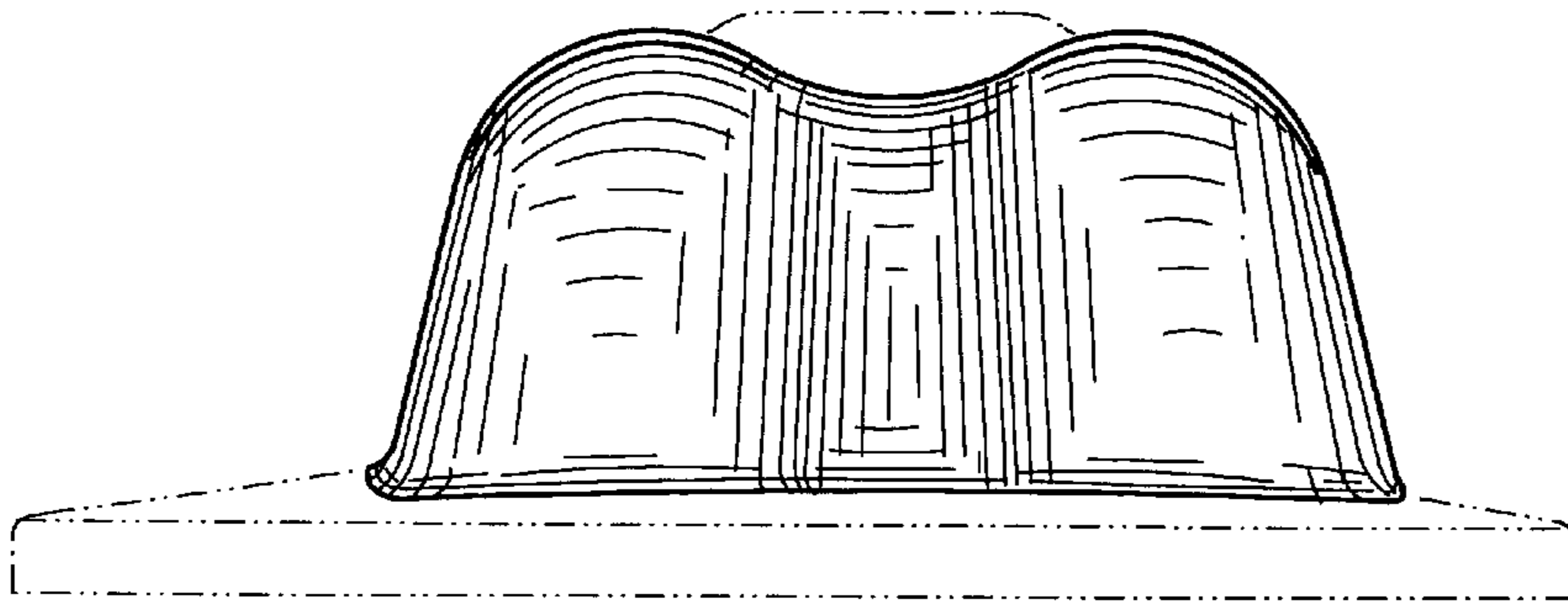

FIG. 5

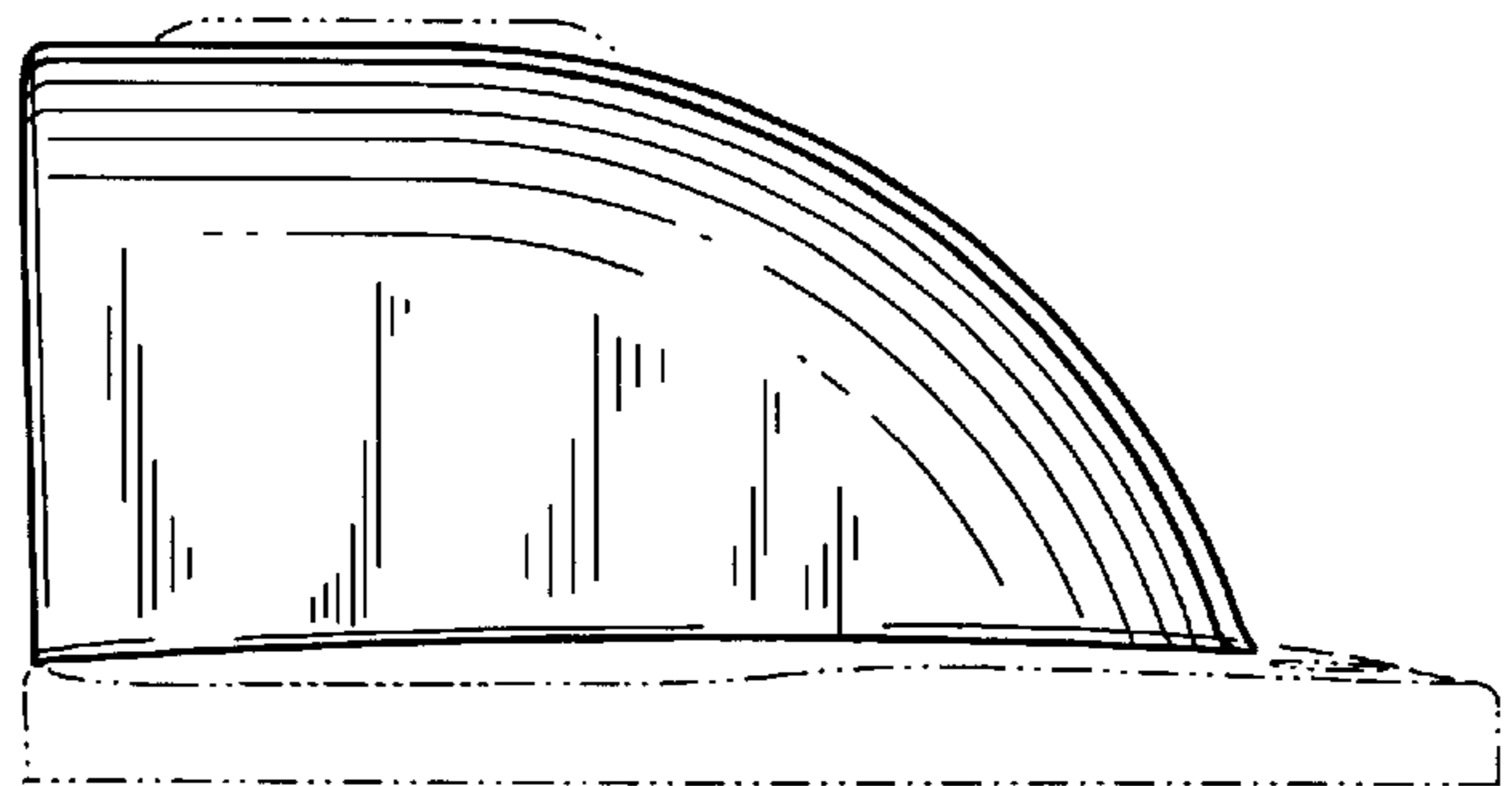

FIG. 6

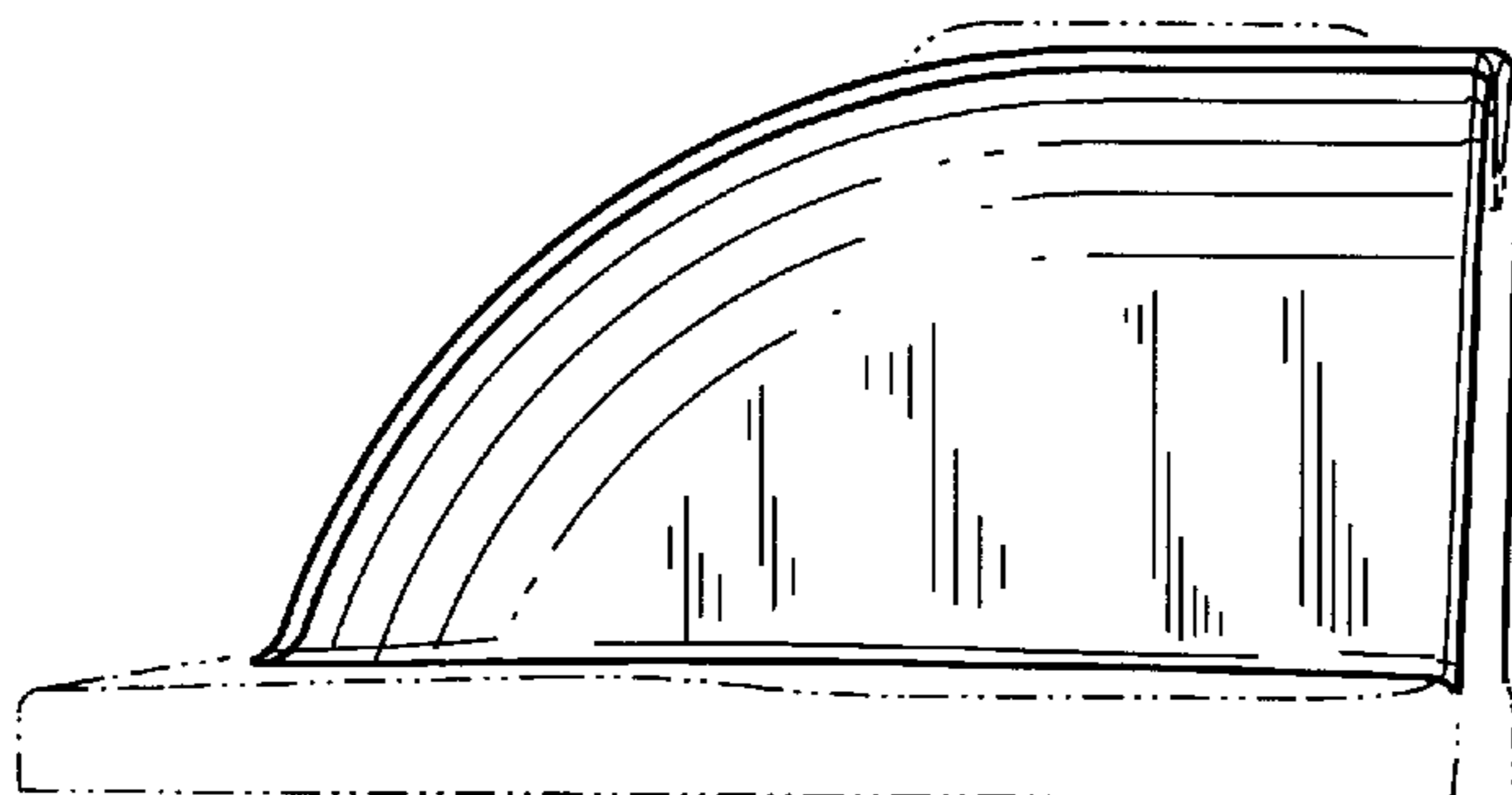

FIG. 7

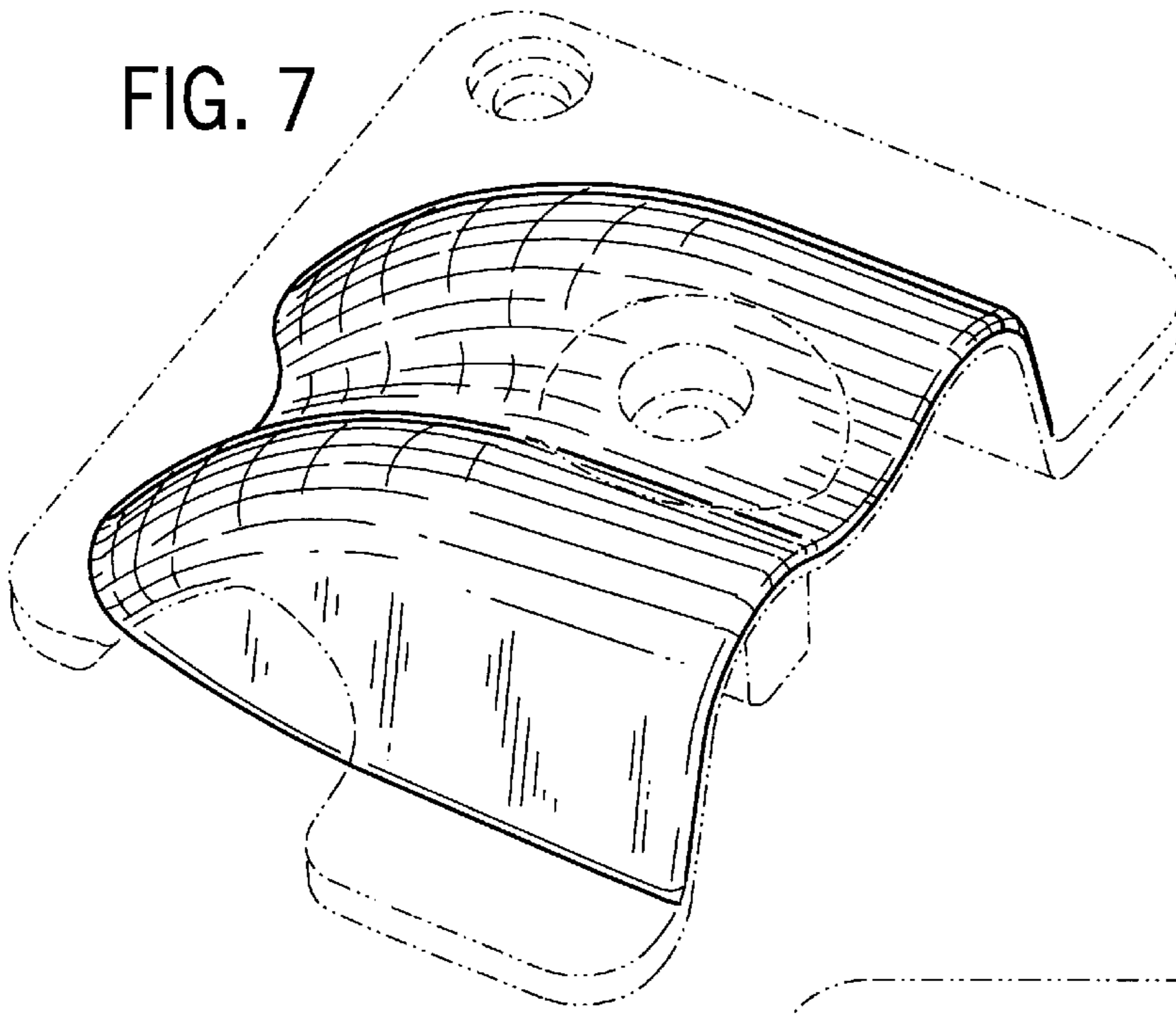

FIG. 8

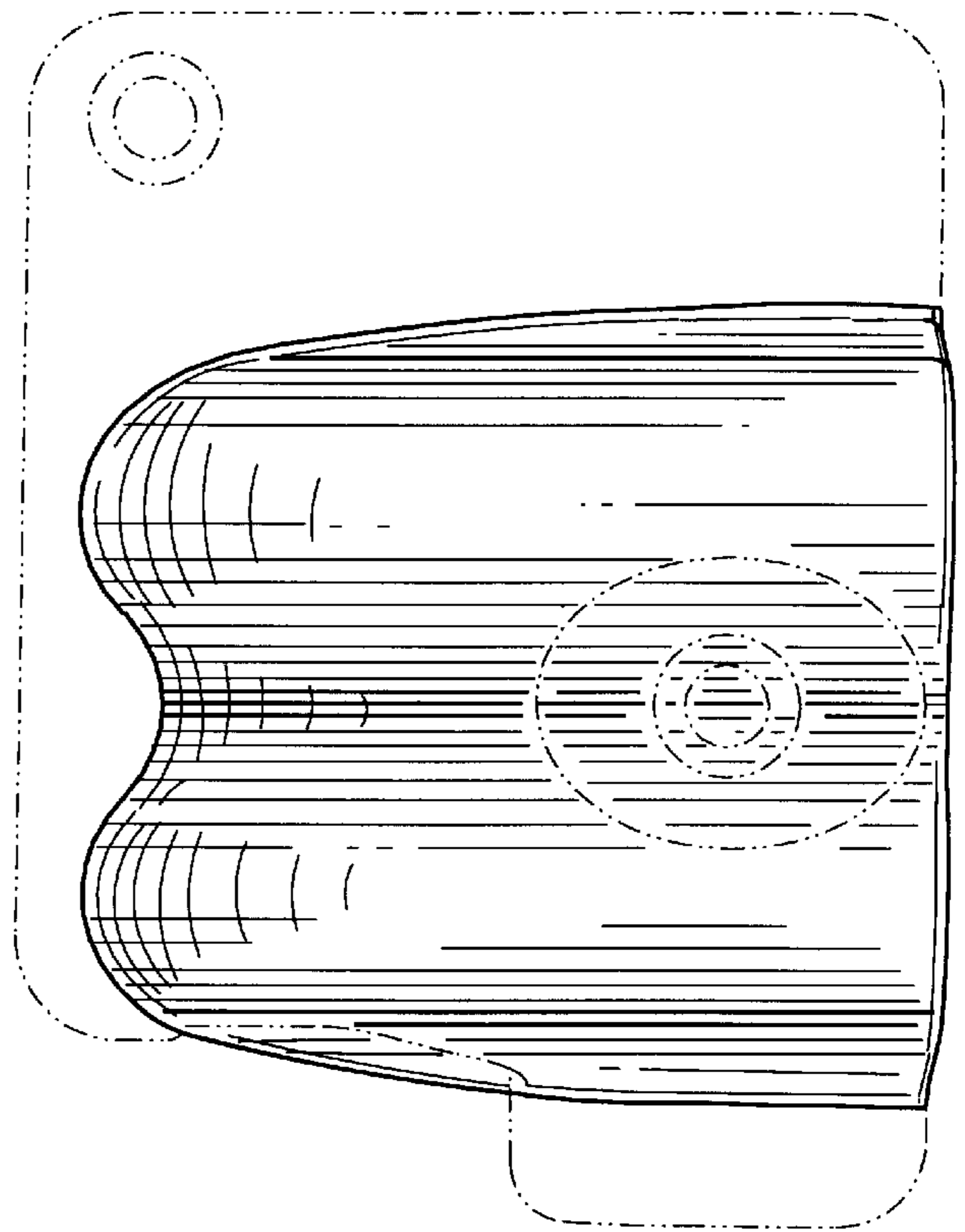

FIG. 9

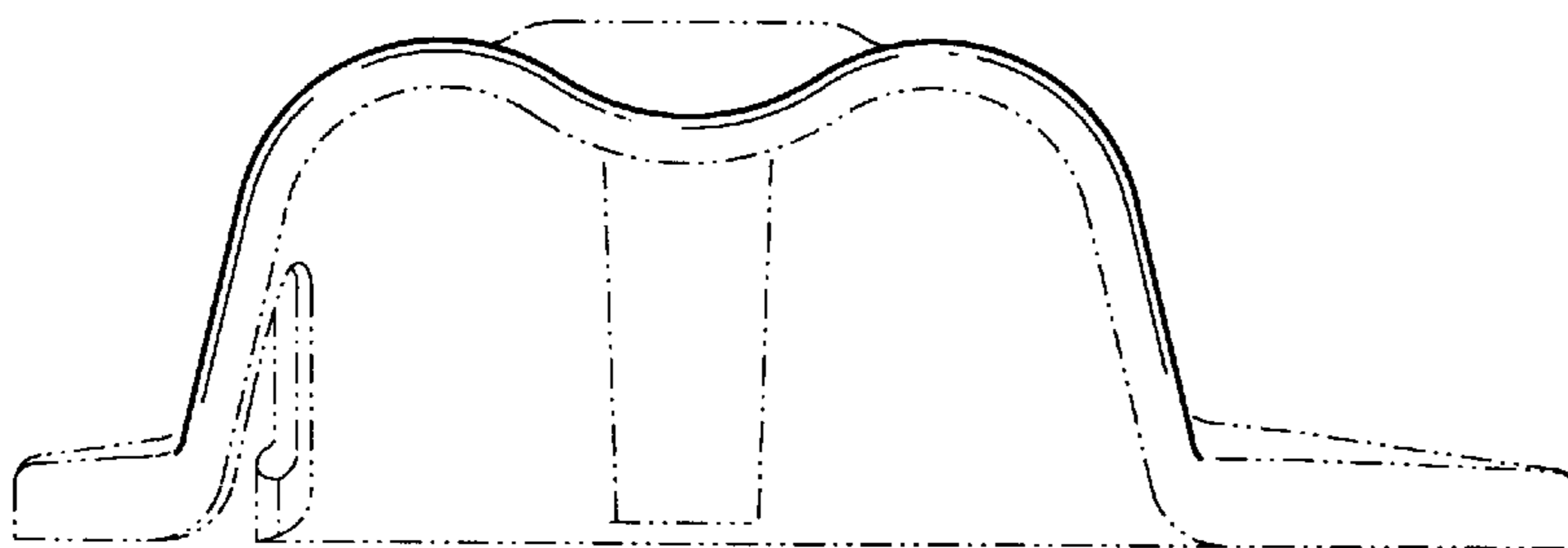

FIG. 10

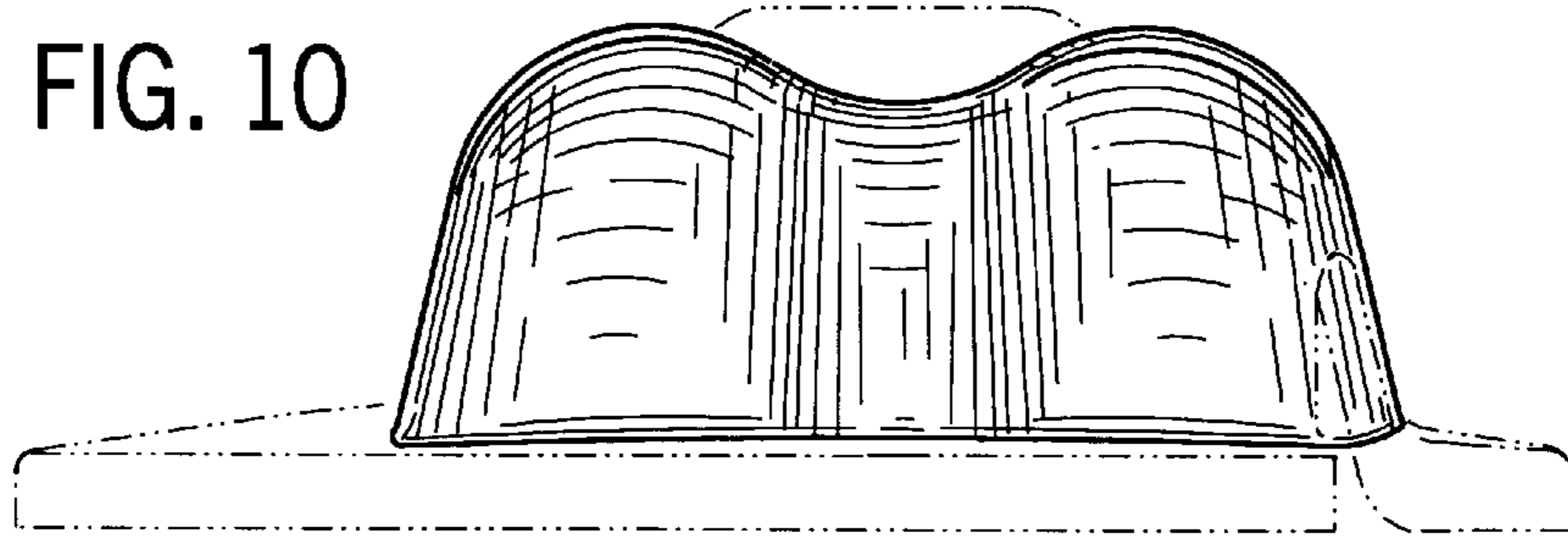

FIG. 11

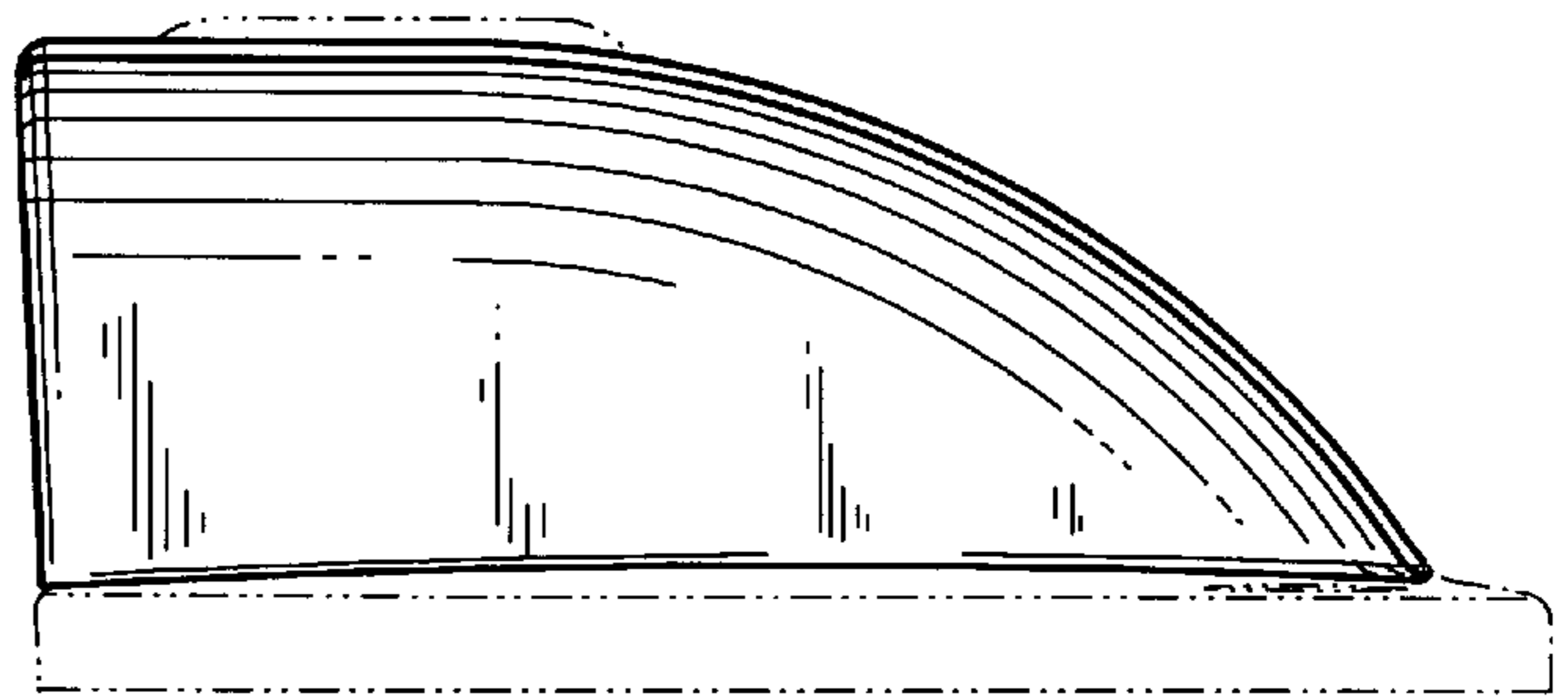

FIG. 12

