



US00D400126S

**United States Patent** [19]  
**Hutchins**

[11] **Patent Number: Des. 400,126**

[45] **Date of Patent: \*\*Oct. 27, 1998**

[54] **MOTORCYCLE BELLY PAN**

[76] Inventor: **Thomas John Hutchins**, 5090 93rd Ave. N., Pinellas Park, Fla. 33782

[\*\*] Term: **14 Years**

[21] Appl. No.: **58,986**

[22] Filed: **Aug. 26, 1996**

[51] **LOC (6) Cl.** ..... **12-11**

[52] **U.S. Cl.** ..... **D12/114**

[58] **Field of Search** ..... D12/126, 114, D12/110; 180/219

[56] **References Cited**

**U.S. PATENT DOCUMENTS**

- D. 274,803 7/1984 Hughes ..... D12/126
- D. 277,948 3/1985 Hurley ..... D12/126
- D. 344,255 2/1994 Opitz ..... D12/126

**OTHER PUBLICATIONS**

Cycle World, Jul. 1996, the front cover & p. 46, the belly pans of the Triumph Trophy & Honda ST 1100 motorcycles.

*Primary Examiner*—Melody N. Brown

*Attorney, Agent, or Firm*—Larson & Larson, P.A.; Herbert W. Larson

[57] **CLAIM**

The ornamental design for a motorcycle belly pan, as shown and described.

**DESCRIPTION**

FIG. 1 is a perspective view of my motorcycle belly pan showing my new design;

FIG. 2 is a left side elevational view thereof;

FIG. 3 is a right side elevational view thereof;

FIG. 4 is a top plan view thereof;

FIG. 5 is a bottom plan view thereof;

FIG. 6 is a front view thereof; and,

FIG. 7 is a rear view thereof.

The broken lines depicting the extended portion of the motorcycle belly pan forms no part of my invention.

**1 Claim, 4 Drawing Sheets**

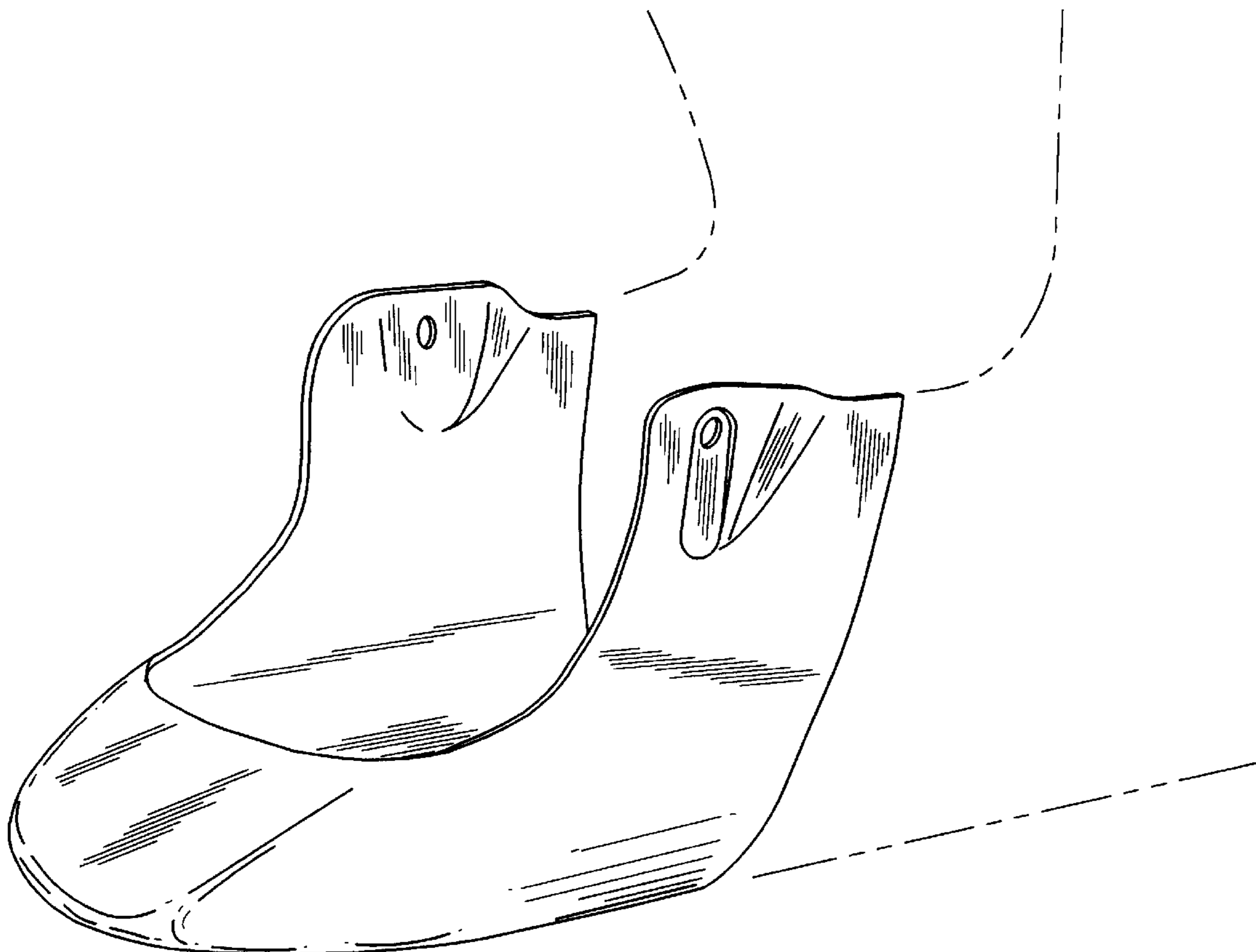

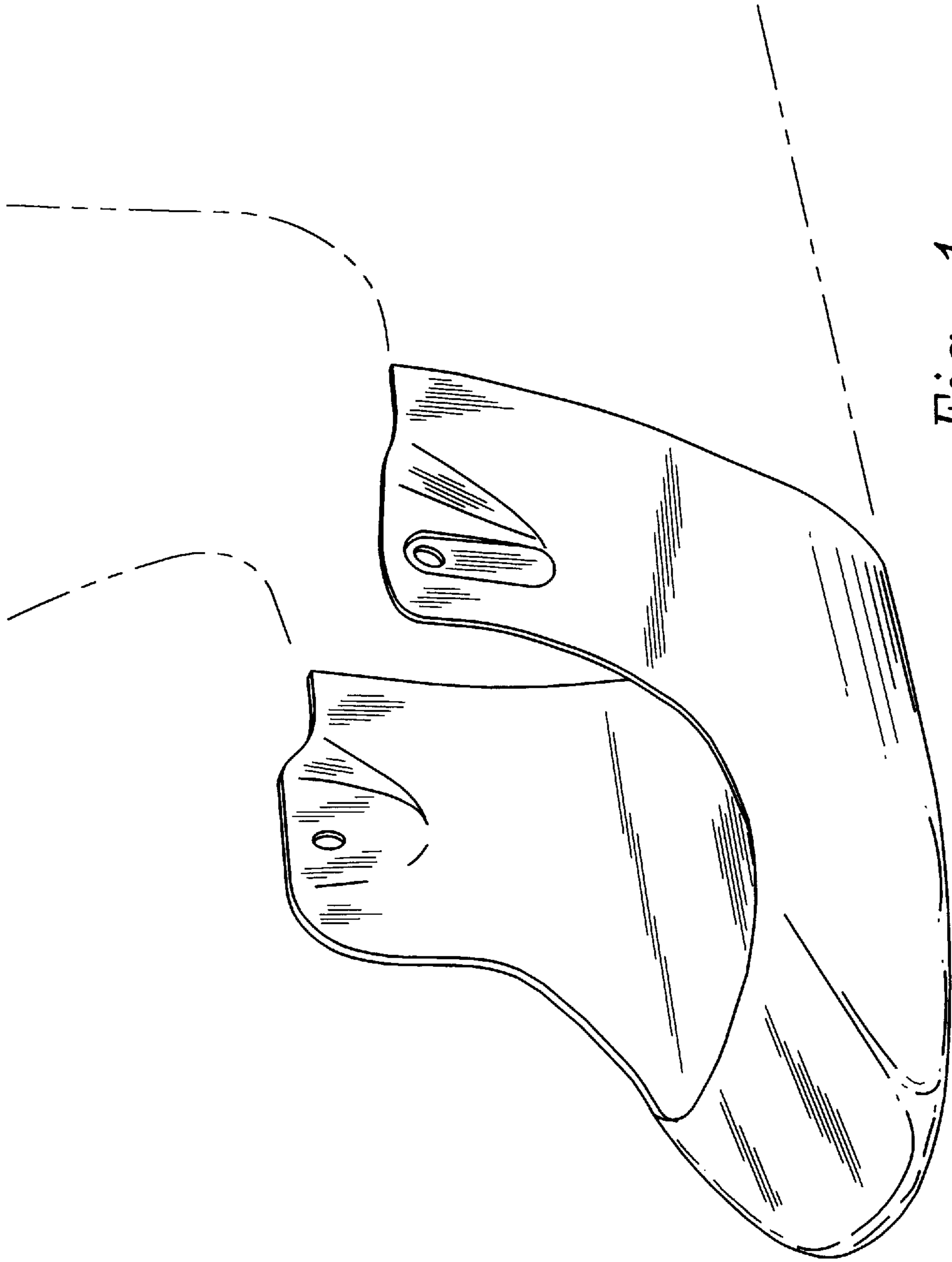

*Fig. 1*

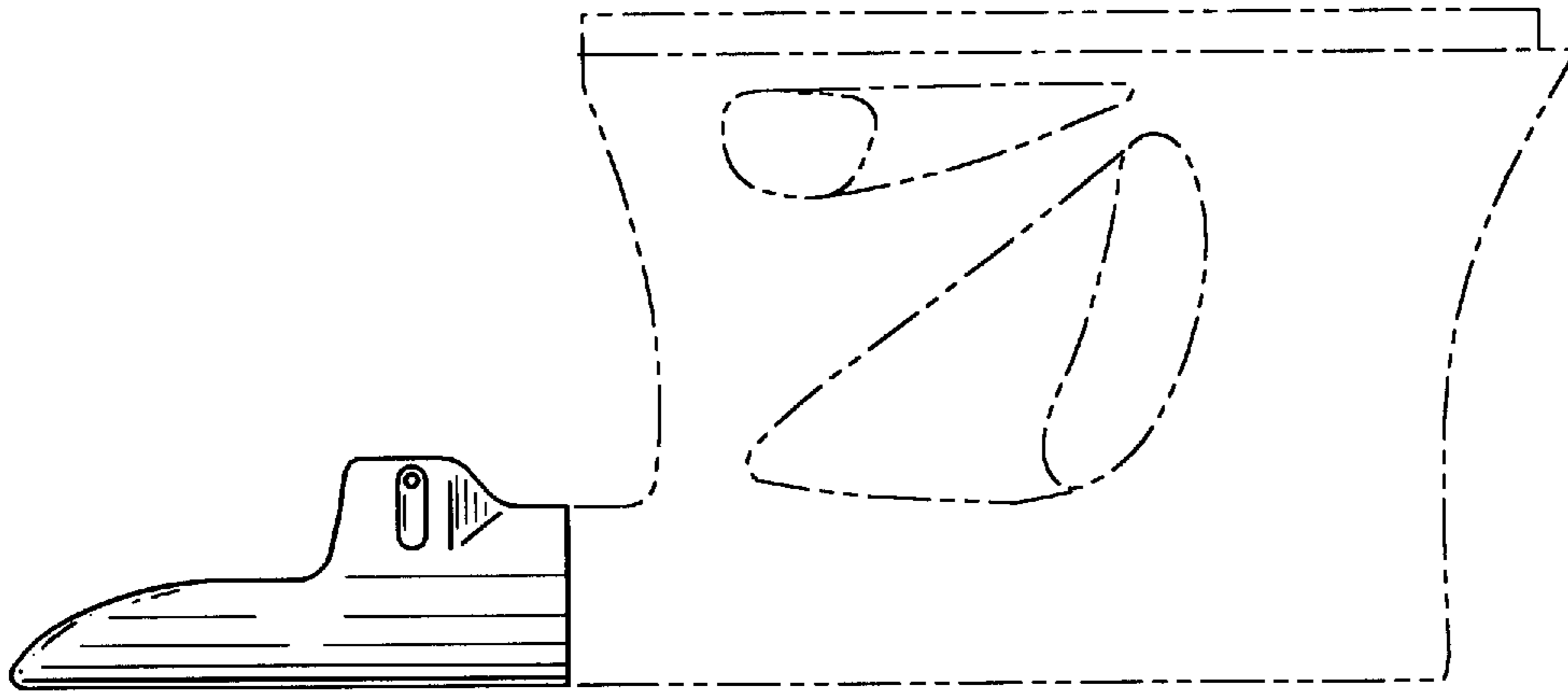

Fig. 2

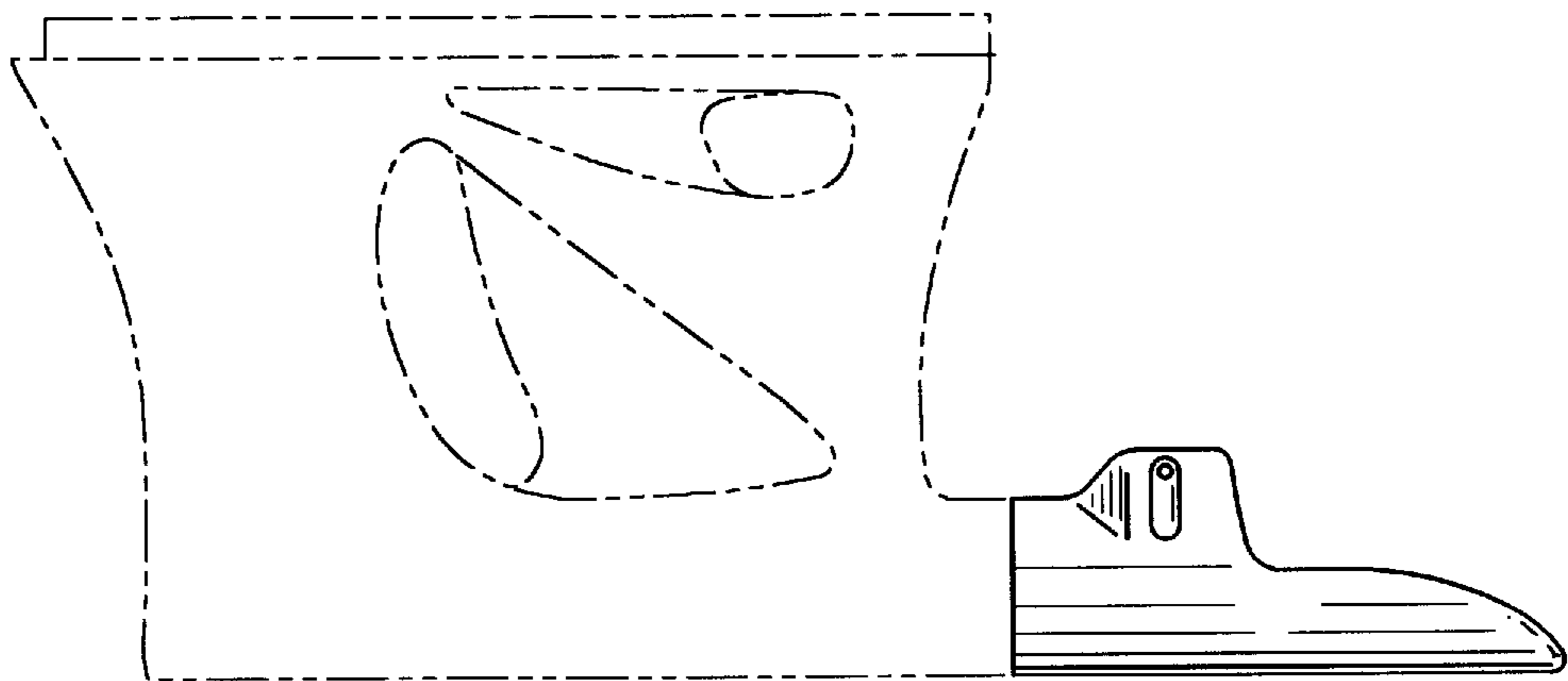

Fig. 3

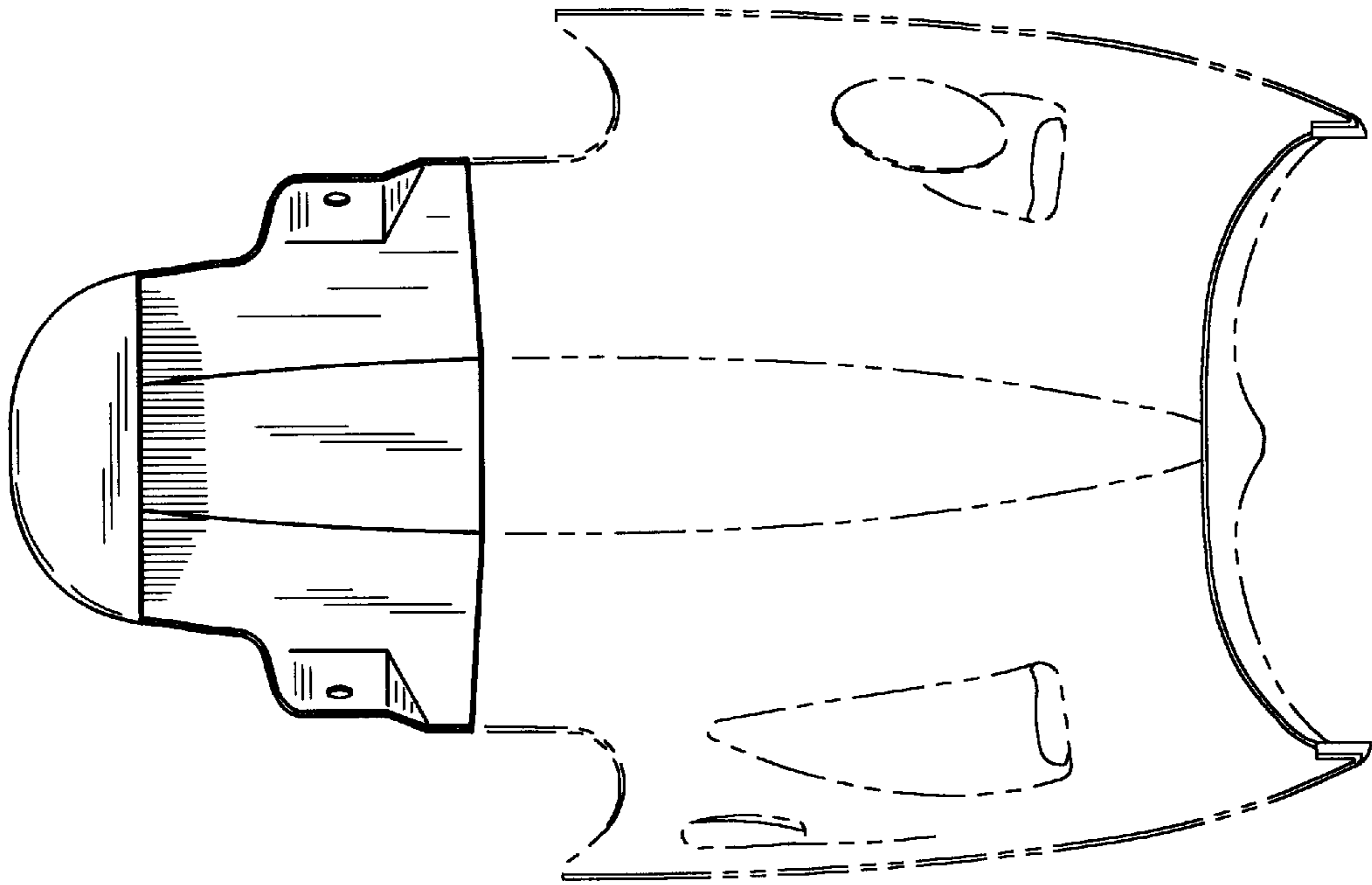

Fig. 4

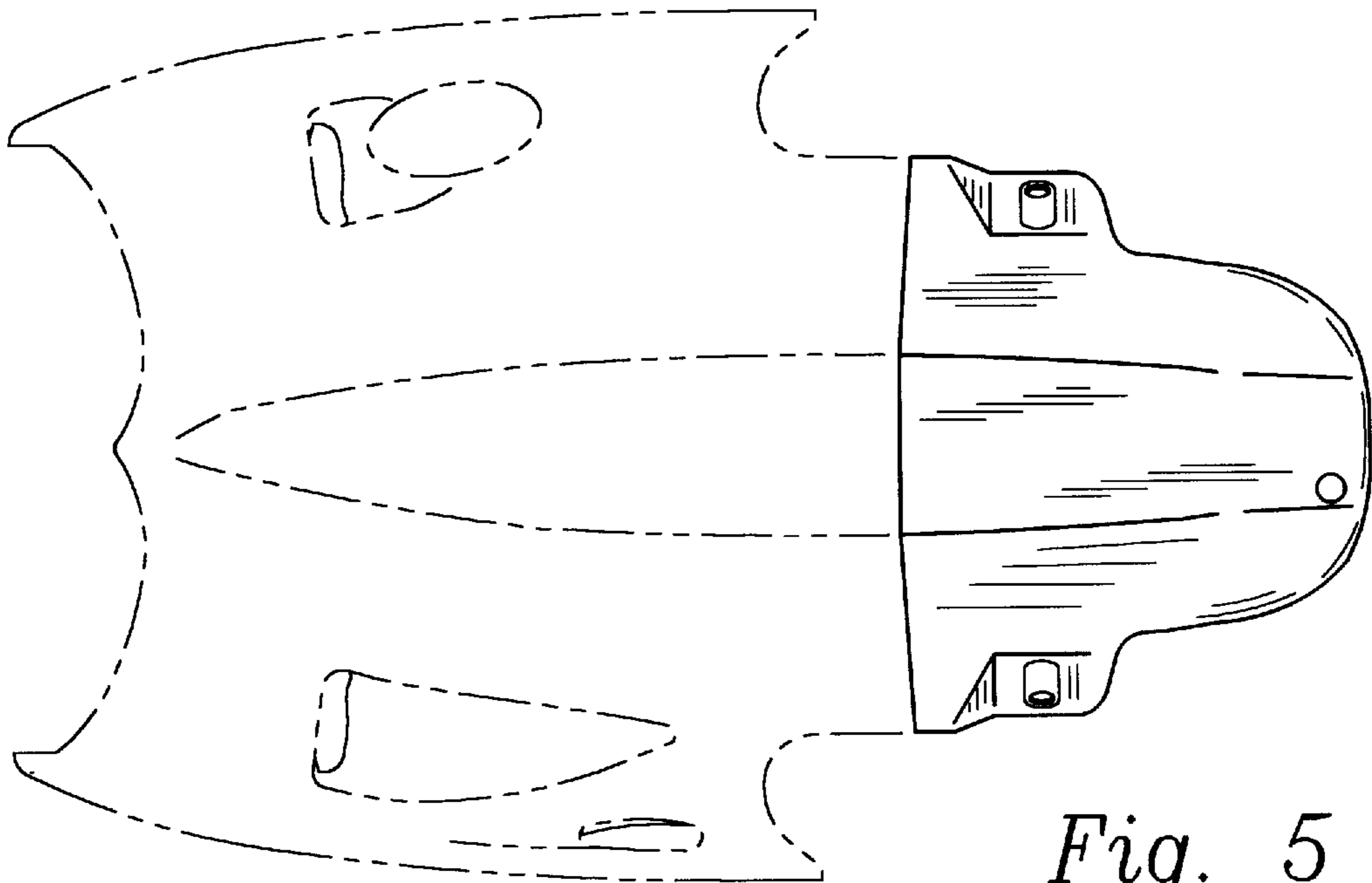

Fig. 5

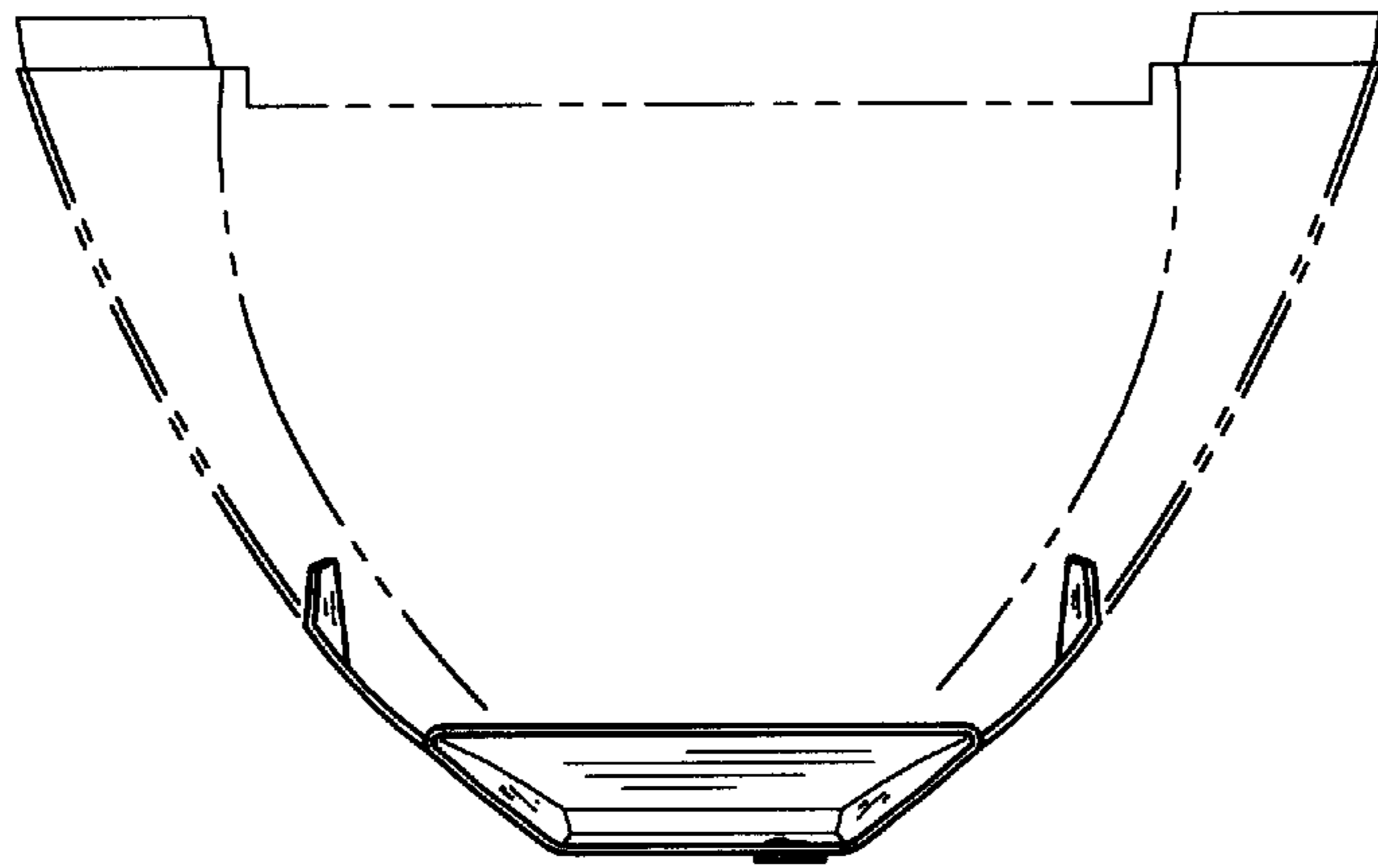

Fig. 6

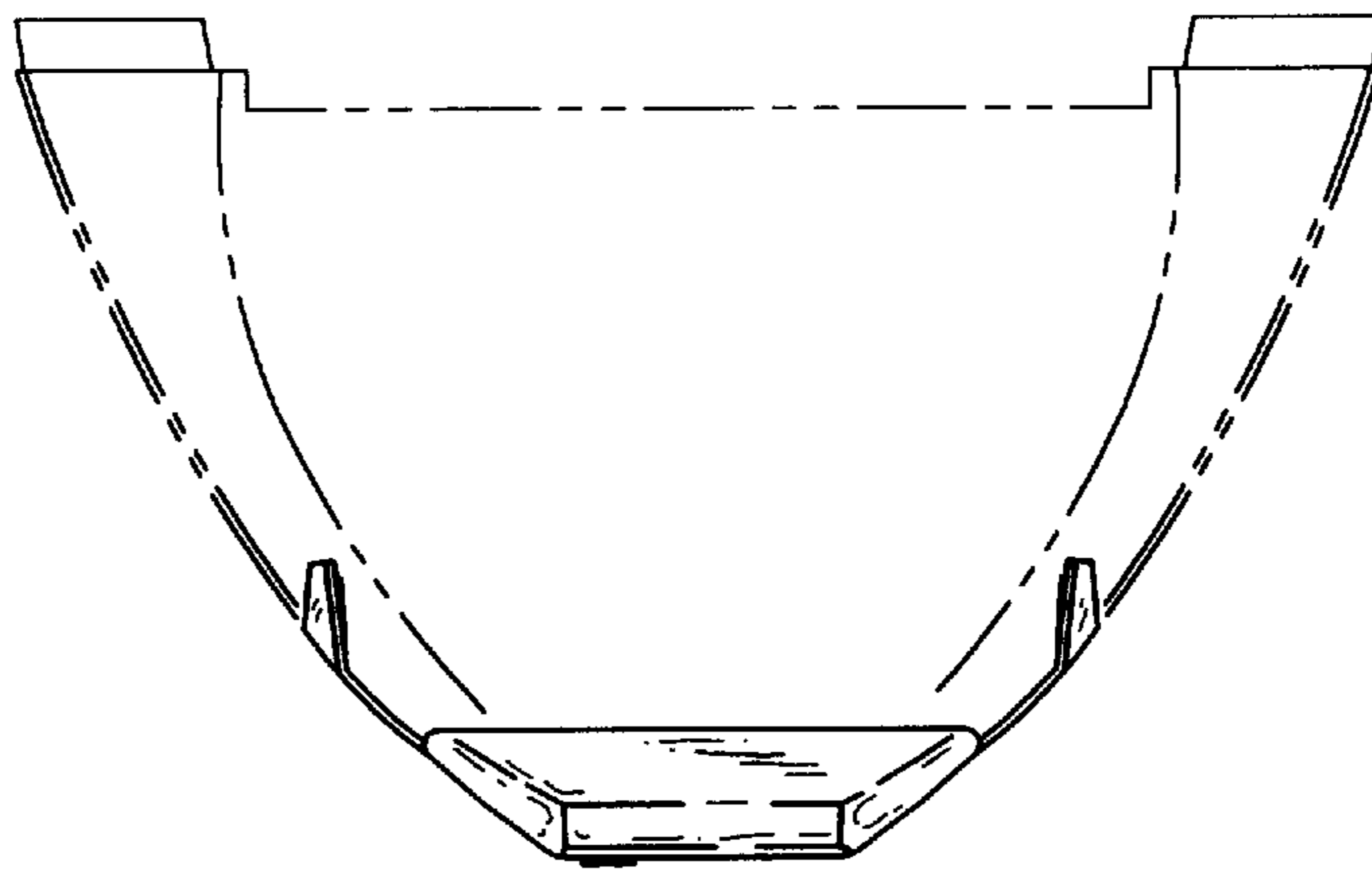

Fig. 7