



US00D400115S

United States Patent [19]

Yaron et al.

[11] Patent Number: **Des. 400,115**

[45] Date of Patent: ****Oct. 27, 1998**

[54] **COMBINED TRANSMITTER AND RECEIVER FOR A VEHICLE PARKING INDICATOR SENSOR**

[75] Inventors: **Michael Yaron**, 936 Moredon Rd., Meadowbrook, Pa. 19046; **Dany Chalhoub**, Woodside, N.Y.; **Joo Hwang Chun**, Pallisades Park, N.J.; **Robert Lachman**, Norwalk, Conn.; **Lex Curtiss**, Long Island City, N.Y.; **Stuart Leslie**, Brooklyn, N.Y.; **Matt Hayduk**, Glen Cove, N.Y.

[73] Assignee: **Michael Yaron**, Meadowbrook, Pa.

[**] Term: **14 Years**

[21] Appl. No.: **78,472**

[22] Filed: **Oct. 27, 1997**

[51] **LOC (6) Cl.** **10-05**

[52] **U.S. Cl.** **D10/104**

[58] **Field of Search** D10/104, 106, D10/116, 121; 340/545, 546, 567, 571, 572, 573, 586

[56] References Cited

U.S. PATENT DOCUMENTS

D. 345,713 4/1994 Pecht et al. D10/106
D. 345,932 4/1994 Jedalizo D10/106

D. 346,125 4/1994 Cote et al. D10/106
D. 346,339 4/1994 Lentick D10/104
D. 348,410 7/1994 Adams et al. D10/104
D. 380,693 7/1997 Serres-Vives D10/104
D. 388,721 1/1998 Kinner D10/104
D. 389,764 1/1998 Howard D10/106

Primary Examiner—Marcus A. Jackson
Attorney, Agent, or Firm—Nixon & Vanderhye P.C.

[57] CLAIM

The ornamental design for a “combined transmitter and receiver for a vehicle parking indicator sensor”, as shown and described.

DESCRIPTION

FIG. 1 is a front perspective view of a combined transmitter and receiver for a vehicle parking indicator sensor according to our design, wherein the connector between the sensor and the indicator shown by broken lines is not part of the claimed design;

FIG. 2 is a top plan view thereof;

FIG. 3 is a front elevational view thereof;

FIG. 4 is a right side elevational view, the left side being a mirror image of the right side elevational view;

FIG. 5 is a bottom plan view thereof;

FIG. 6 is a rear elevational view thereof; and,

FIG. 7 is a rear elevational view of an alternative embodiment thereof.

1 Claim, 7 Drawing Sheets

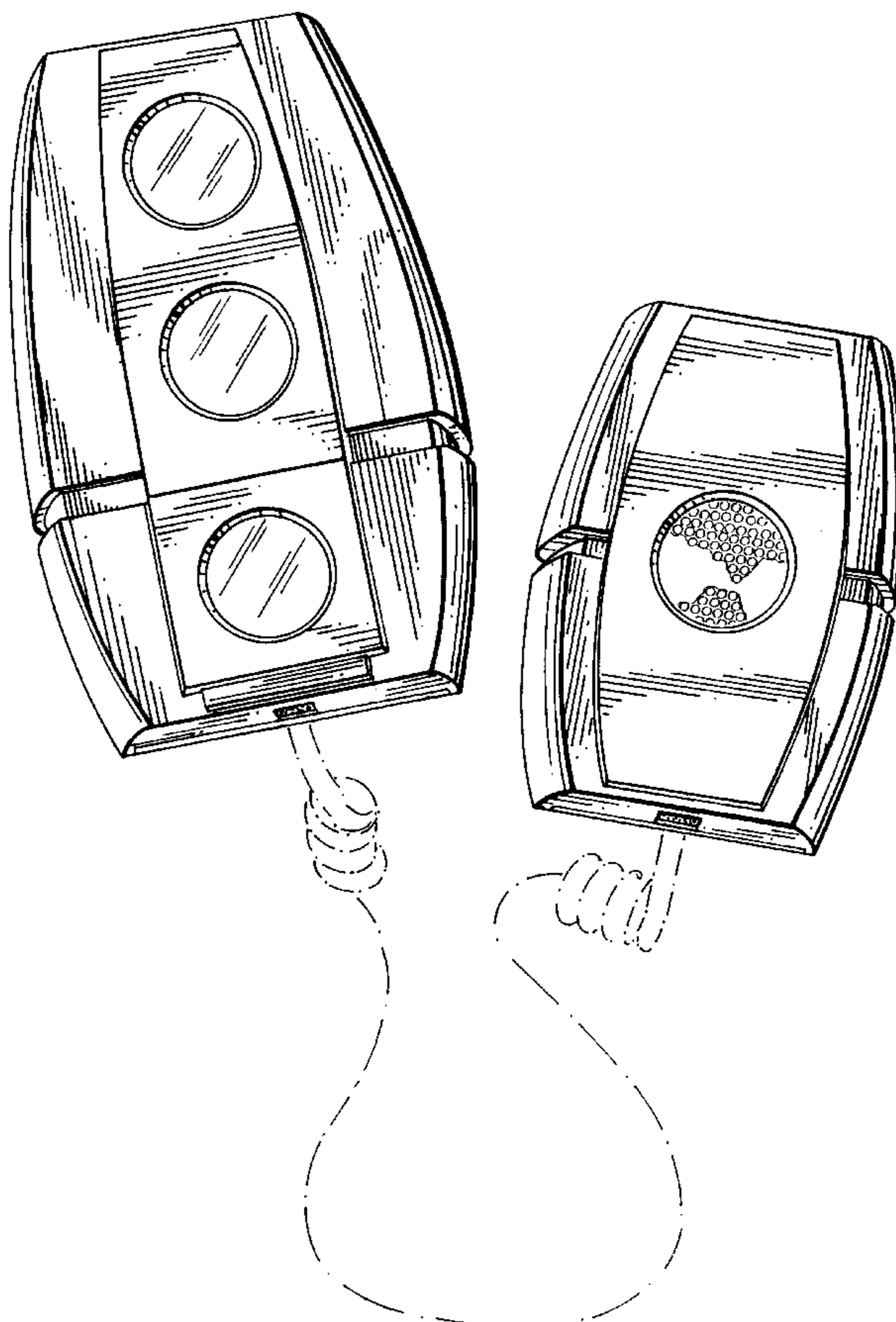

Fig. 1

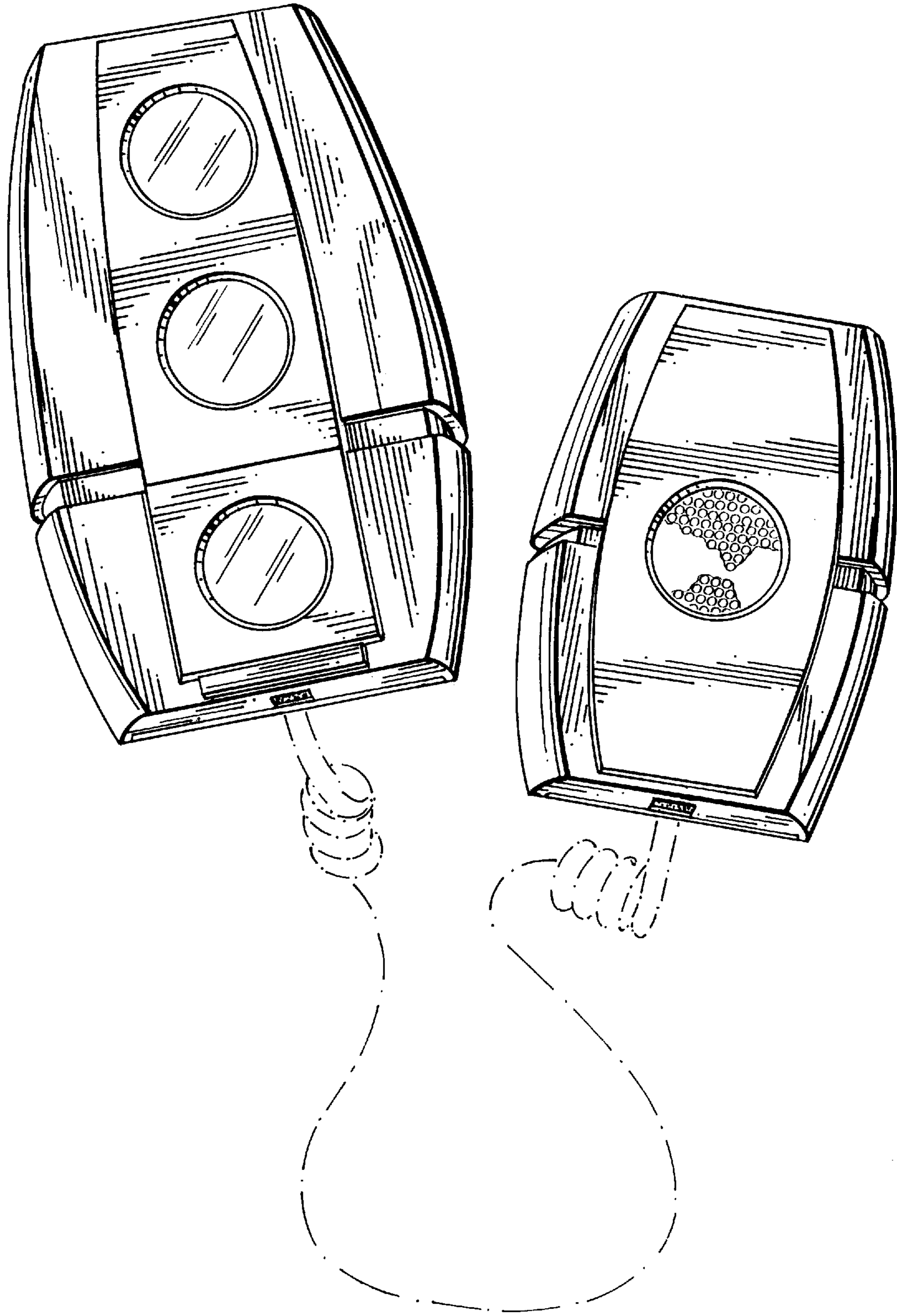

Fig. 2

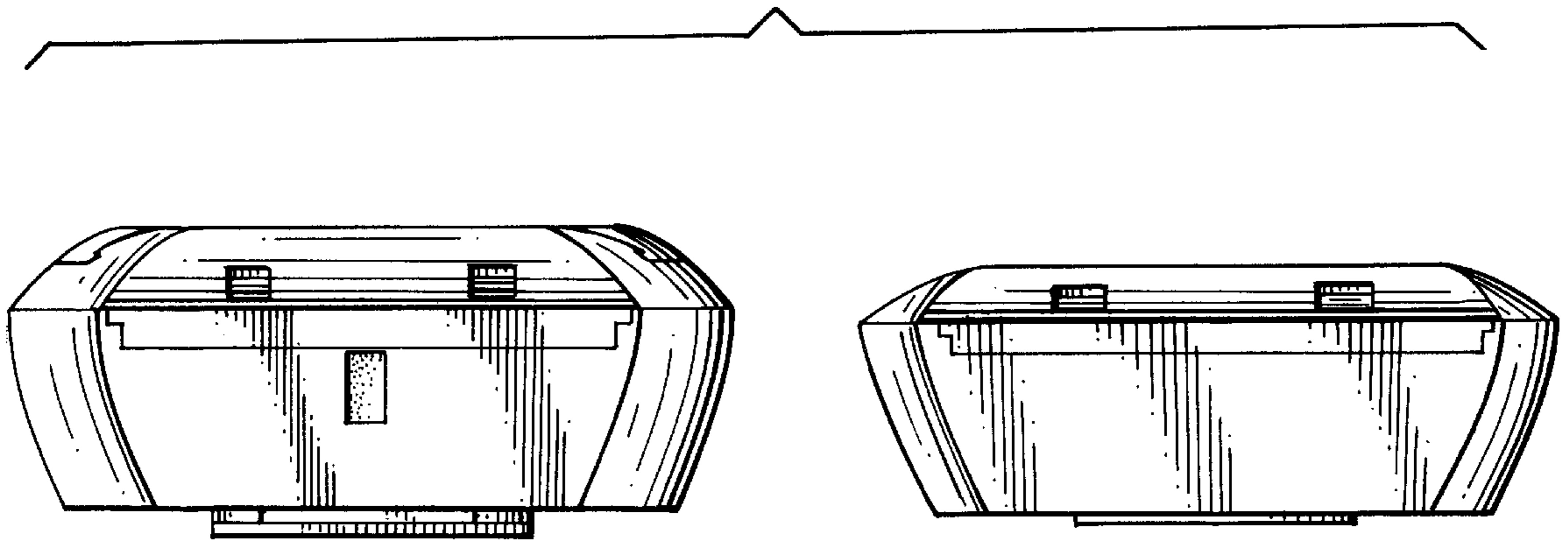

Fig. 3

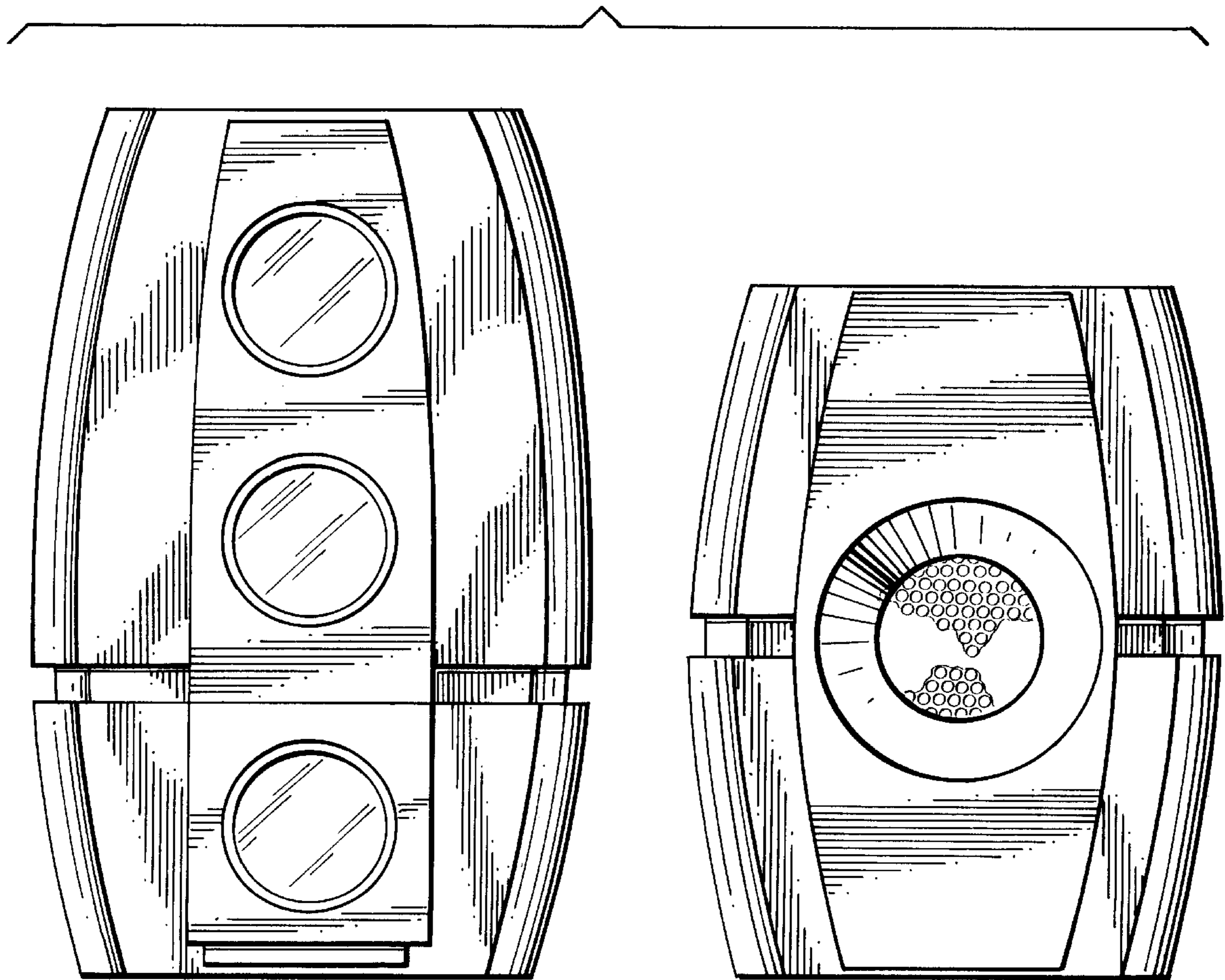

Fig. 4

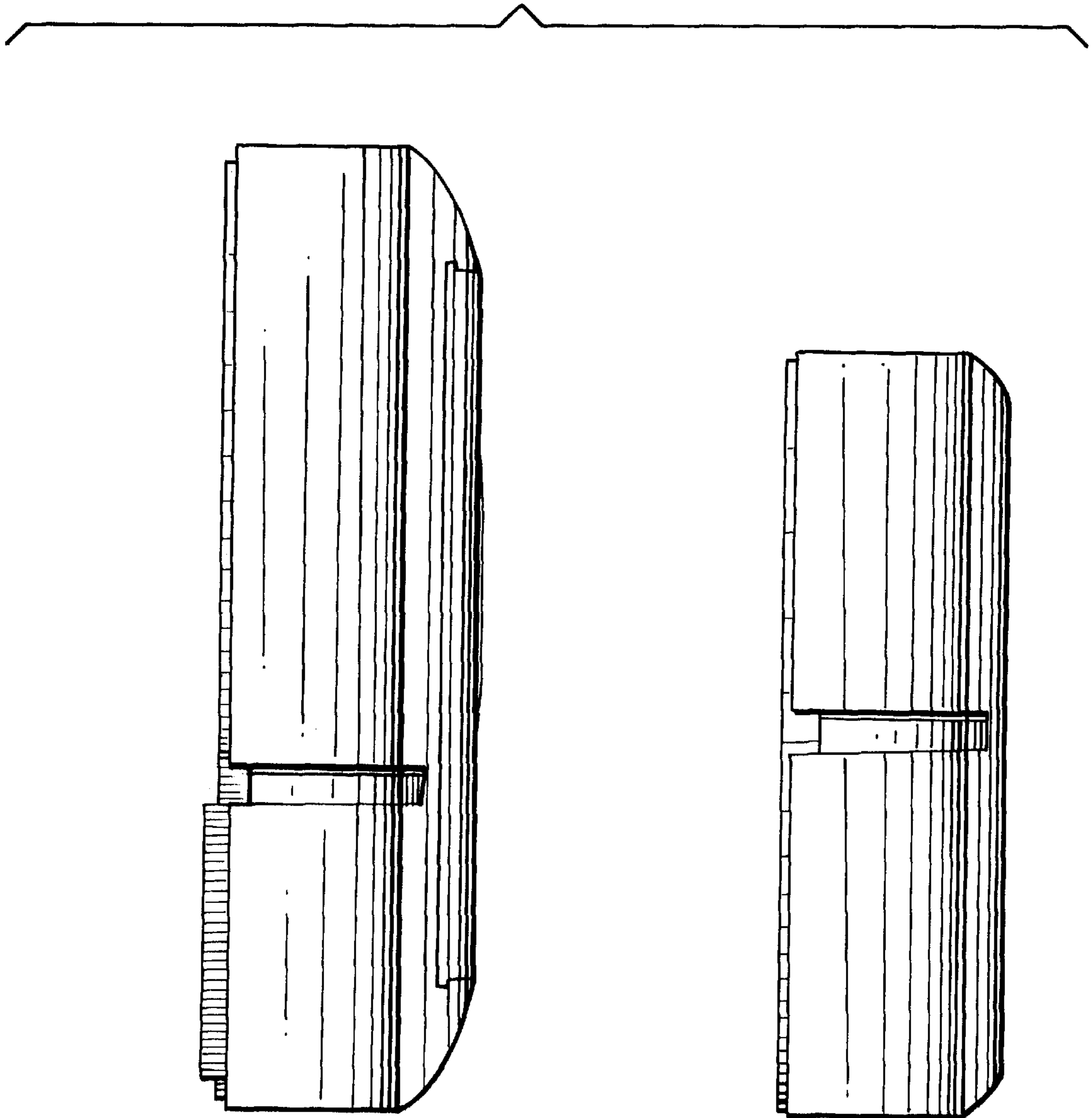

Fig. 5

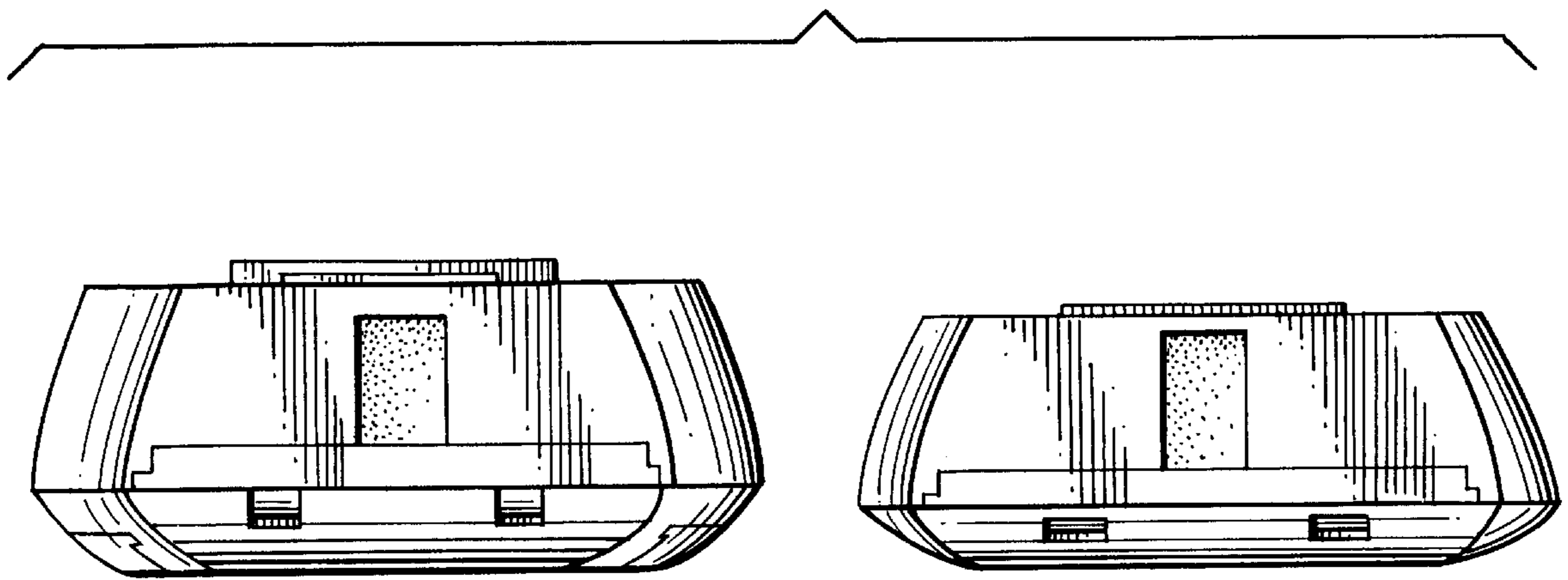

Fig. 6

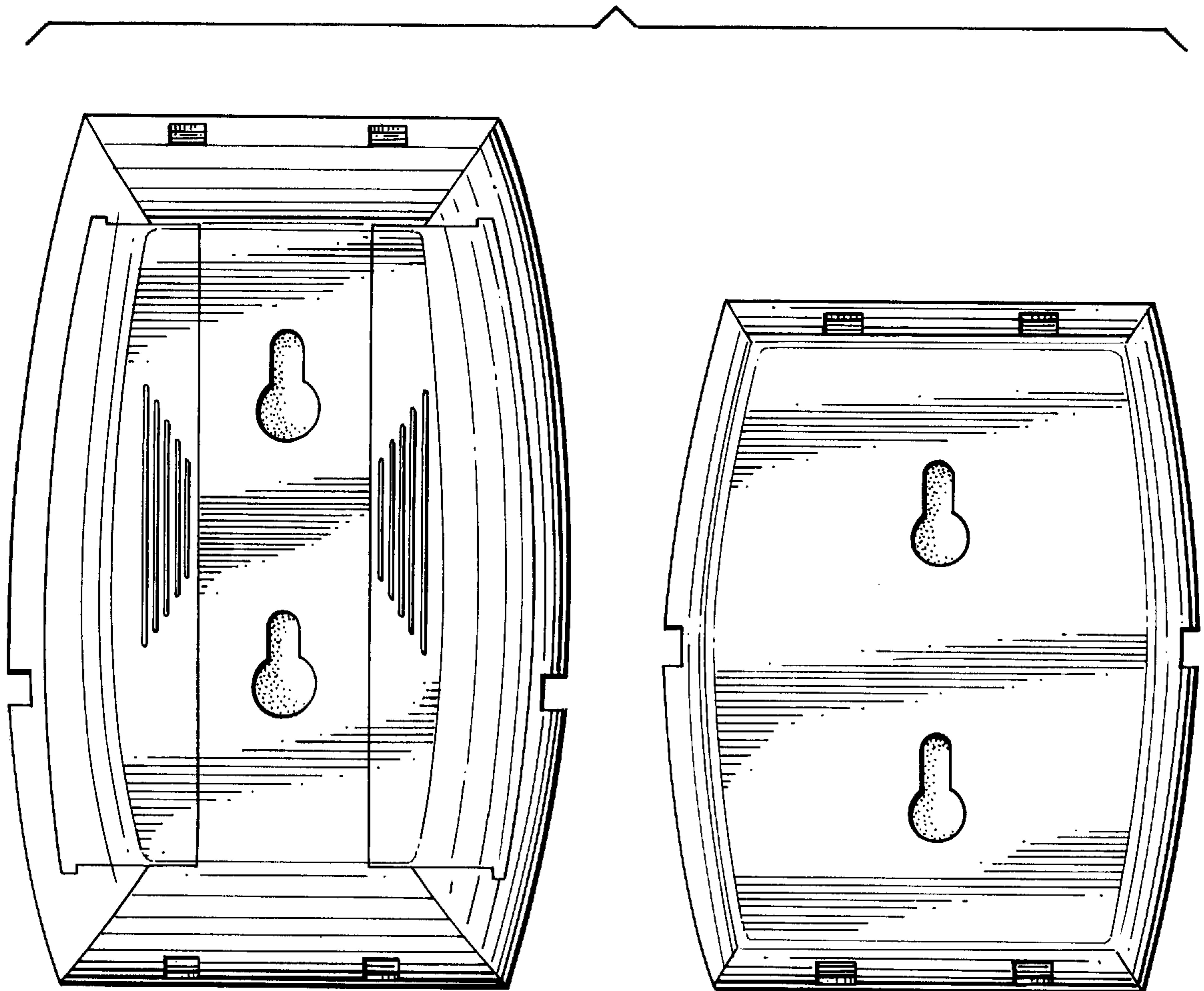

Fig. 7

