



US00D399817S

United States Patent [19]

[11] **Patent Number: Des. 399,817**

Lund et al.

[45] **Date of Patent: **Oct. 20, 1998**

- [54] **PICKUP TRUCK CAB EXTENDING TONNEAU COVER**
- [75] Inventors: **David M. Lund**, Andover; **Joel E. Johnson**, Coon Rapids, both of Minn.
- [73] Assignee: **Lund Industries, Incorporated**, Anoka, Minn.
- [**] Term: **14 Years**
- [21] Appl. No.: **61,875**
- [22] Filed: **Nov. 1, 1996**
- [51] **LOC (6) Cl.** **12-16**
- [52] **U.S. Cl.** **D12/404**
- [58] **Field of Search** D12/401, 404, D12/198, 183; 296/100, 76

5,228,736	7/1993	Dutton	296/39.2
5,275,458	1/1994	Barben et al.	296/100
5,301,995	4/1994	Isler	296/100
5,328,310	7/1994	Lockney	410/97
5,335,960	8/1994	Benignu, Jr.	296/165
5,385,377	1/1995	Girard	296/36
5,398,985	3/1995	Robinson	296/100

OTHER PUBLICATIONS

Photographs marked "Exhibit A" showing a tonneau cover device on the bed of a Sierra GMC pickup truck. Photos taken Jul. 1996.

Photographs marked "Exhibit B" showing a tonneau cover device on the bed of a Chevrolet pickup truck. Photos taken Aug. 1996.

Brochure: "World's Finest Camper Tops®", Tri-Glas VMC Fiberglass, Inc., Daleville, Alabama.

Primary Examiner—James Gandy
Assistant Examiner—Stacia Sinuik
Attorney, Agent, or Firm—Merchant, Gould, Smith, Edell, Welter & Schmidt, P.A.

[56] References Cited

U.S. PATENT DOCUMENTS

D. 235,327	6/1975	Morris	D12/401
D. 281,487	11/1985	Chapman	D12/156
D. 294,242	2/1988	O'Neill	D12/156
D. 323,479	1/1992	Akashi et al.	D12/156
D. 324,195	2/1992	Ueno	D12/156
D. 332,072	12/1992	Shirlin et al.	D12/401 X
D. 333,289	2/1993	Shirlin et al.	D12/401 X
D. 333,607	3/1993	Isler	D8/382
D. 337,554	7/1993	Lucas	D12/156
D. 350,107	8/1994	Ramaciotti	D12/401
D. 373,985	9/1996	Weaver et al.	D12/401
3,936,077	2/1976	Blick	280/423 R
3,954,296	5/1976	Ratnode	296/100
4,061,394	12/1977	Vodin	296/100
4,273,377	6/1981	Alexander	296/100
4,285,539	8/1981	Cole	296/105
4,377,307	3/1983	Santarelli	296/136
4,479,677	10/1984	Gulette et al.	296/98
4,573,730	3/1986	Gondert et al.	296/1 S
4,600,233	7/1986	Boydston	296/24 R
4,687,247	8/1987	Muscat	296/136
4,792,178	12/1988	Kokx	296/98
4,799,729	1/1989	Muscat	296/136
4,861,092	8/1989	Bogard	296/100
5,067,768	11/1991	Fischbach	296/107
5,139,375	8/1992	Franchuk	410/105
5,183,309	2/1993	Jordan	296/100
5,207,262	5/1993	Rushford	160/354

[57] CLAIM

The ornamental design for pickup truck cab extending tonneau cover, as shown and described.

DESCRIPTION

FIG. 1 is a perspective view of the pickup truck cab extending tonneau cover showing our new design, it being understood that the broken lines are for illustrative purposes to show the outline of a pickup truck;

FIG. 2 is a top plan view of the pickup truck cab extending tonneau cover;

FIG. 3 is an elevation view of the rearward side of the pickup truck cab extending tonneau cover;

FIG. 4 is an elevation view of the forward side of the pickup truck cab extending tonneau cover; and,

FIG. 5 is an elevation view of the right side of the pickup truck cab extending tonneau cover.

It should be appreciated that the elevation view of the left side of the pickup truck cab extending tonneau cover is a mirror image of FIG. 5; and the bottom of the pickup truck cab extending tonneau cover forms no part of the claimed design.

1 Claim, 4 Drawing Sheets

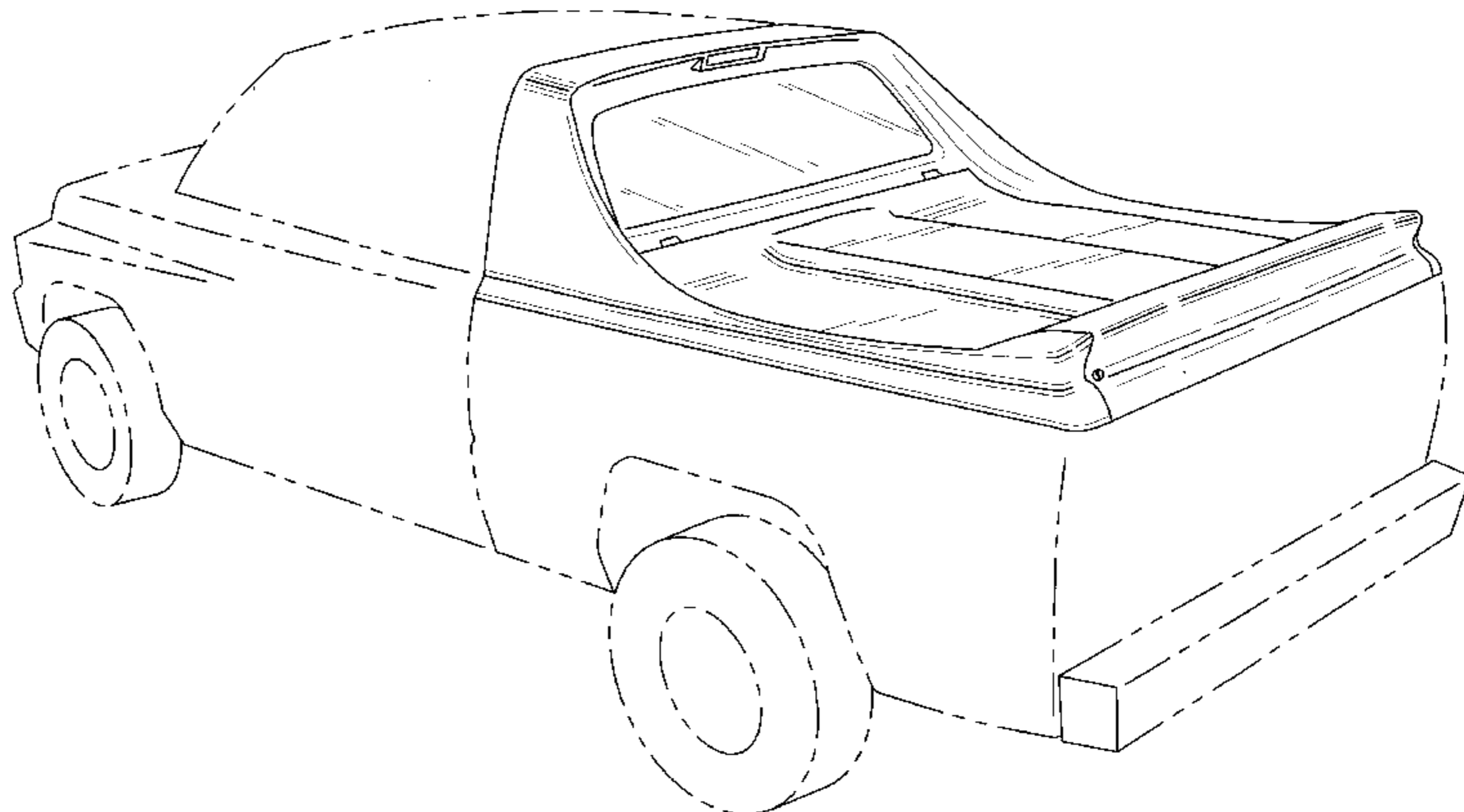

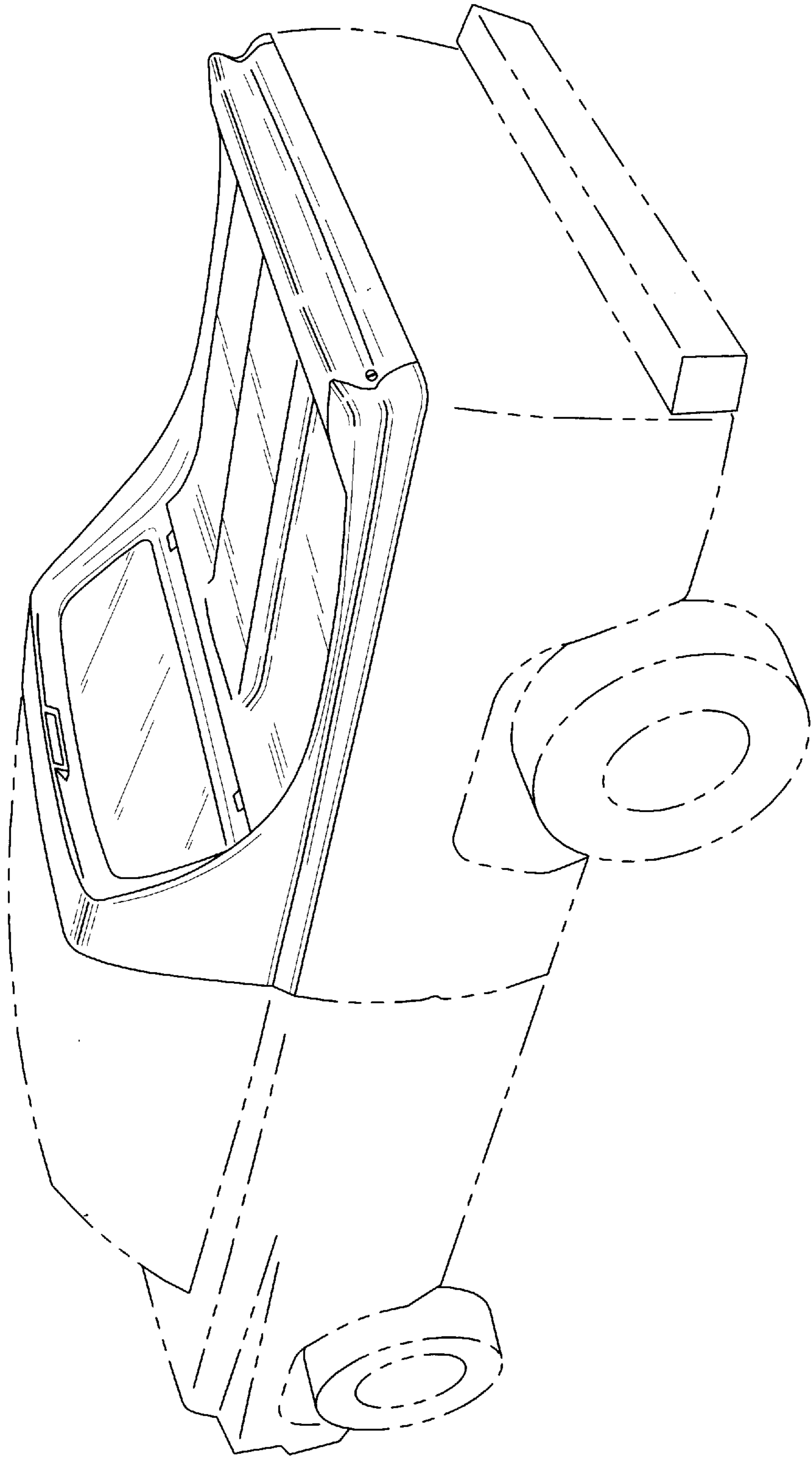

FIG. 1

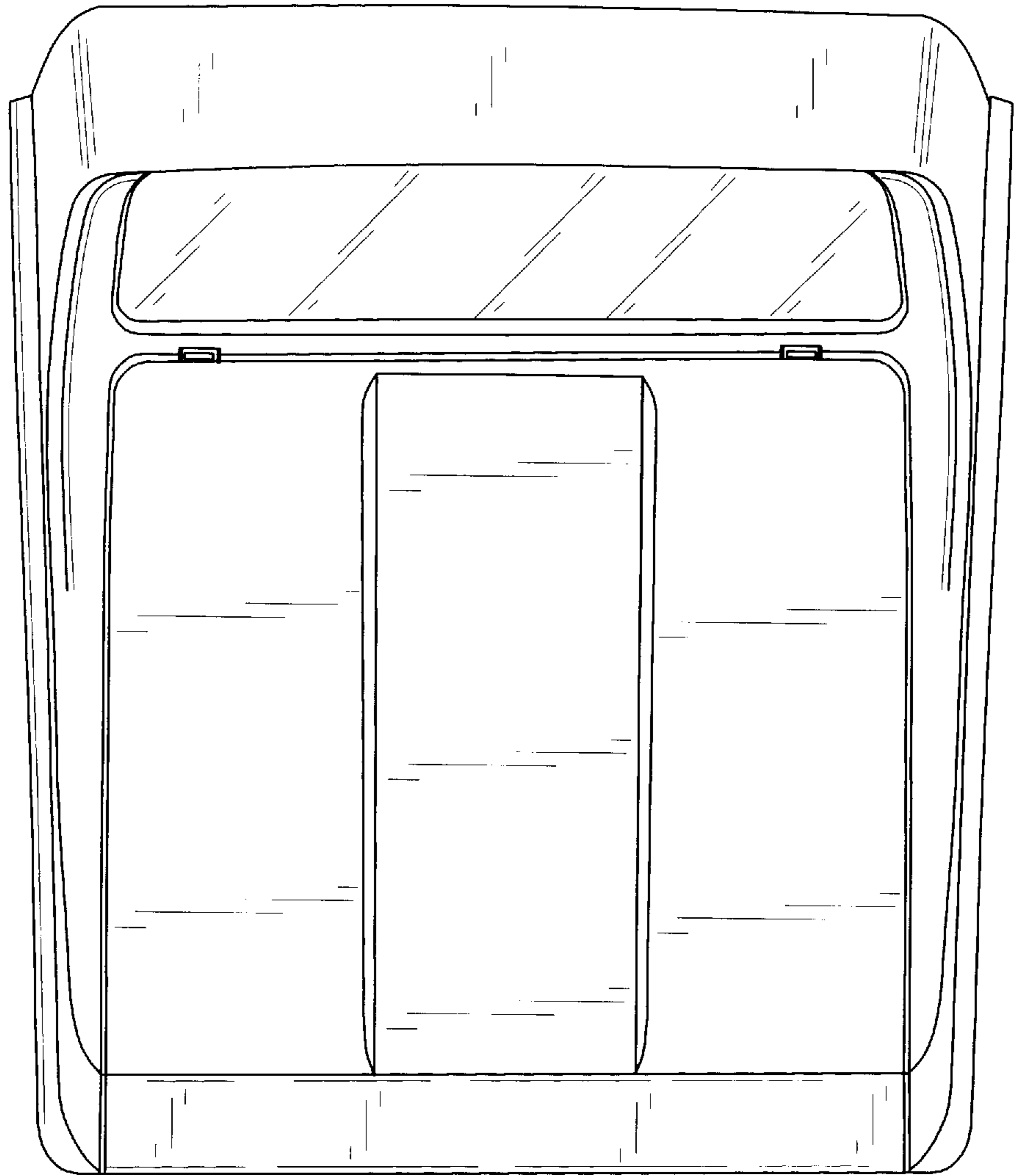

FIG. 2

FIG. 3

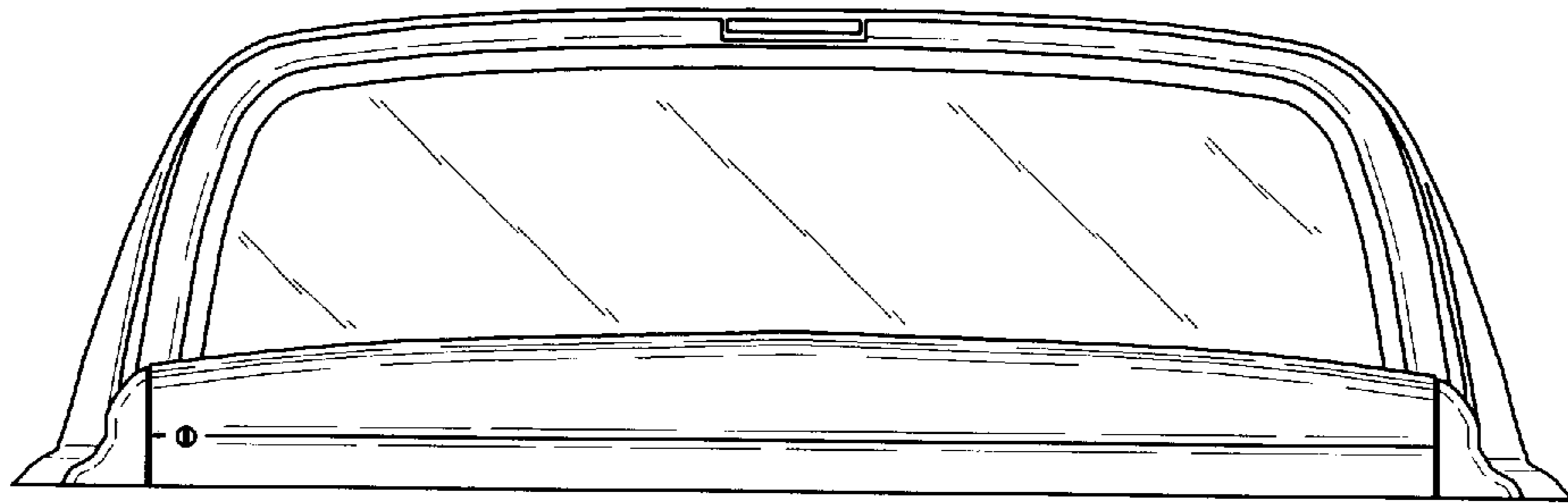
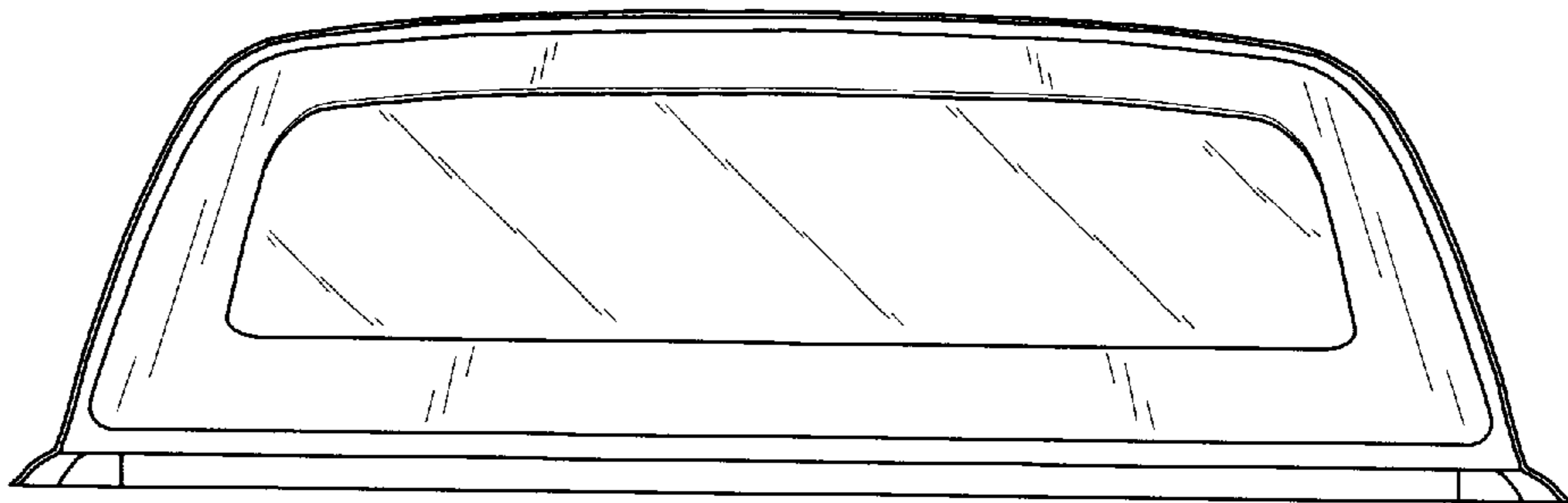

FIG. 4



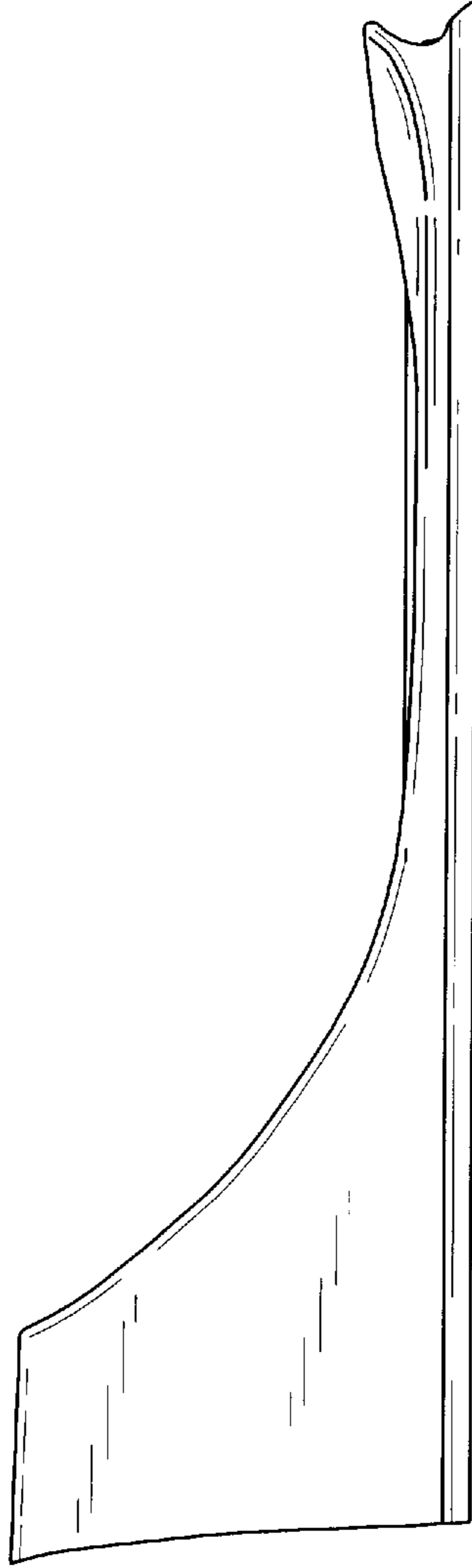

FIG. 5