



US00D399815S

# United States Patent [19]

Martin et al.

[11] **Patent Number: Des. 399,815**

[45] **Date of Patent: \*\*Oct. 20, 1998**

[54] **BLIMP**

4,773,617 9/1988 McCampbell ..... 244/24

[76] Inventors: **John Martin; Ian Carwardine**, both of  
c/o Unit 1, 43 Roydon Place, Nepean,  
Ontario, Canada, K2E 1A3

### OTHER PUBLICATIONS

Jane's All the World's Aircraft 1995-1996, p. 675 "SARI  
Shen Zhou-2".

[\*\*] Term: **14 Years**

UK: Airships—Aerospace Developments/Cameron, p. 594,  
1976-77.

[21] Appl. No.: **51,355**

A Pictorial History of the World War II Years by Jablonski,  
Copyright 1977.

[22] Filed: **Mar. 7, 1996**

*Primary Examiner*—Kay H. Chin  
*Attorney, Agent, or Firm*—Baker & Daniels

### [30] Foreign Application Priority Data

Sep. 7, 1995 [CA] Canada ..... 1995-1993

### [57] CLAIM

[51] **LOC (6) Cl.** ..... **12-07**

The ornamental design for a blimp, as shown and described.

[52] **U.S. Cl.** ..... **D12/323**

### DESCRIPTION

[58] **Field of Search** ..... D12/300, 323;  
244/30, 24, 97, 128, 115; D21/84

FIG. 1 is a side plan view of the blimp which is a mirror  
image of the opposite side plan view of the blimp;  
FIG. 2 is a rear perspective view of the blimp; and,  
FIG. 3 is a front view of the blimp.

### [56] References Cited

#### U.S. PATENT DOCUMENTS

D. 358,575 5/1995 Glasgow et al. .... D12/323

**1 Claim, 2 Drawing Sheets**

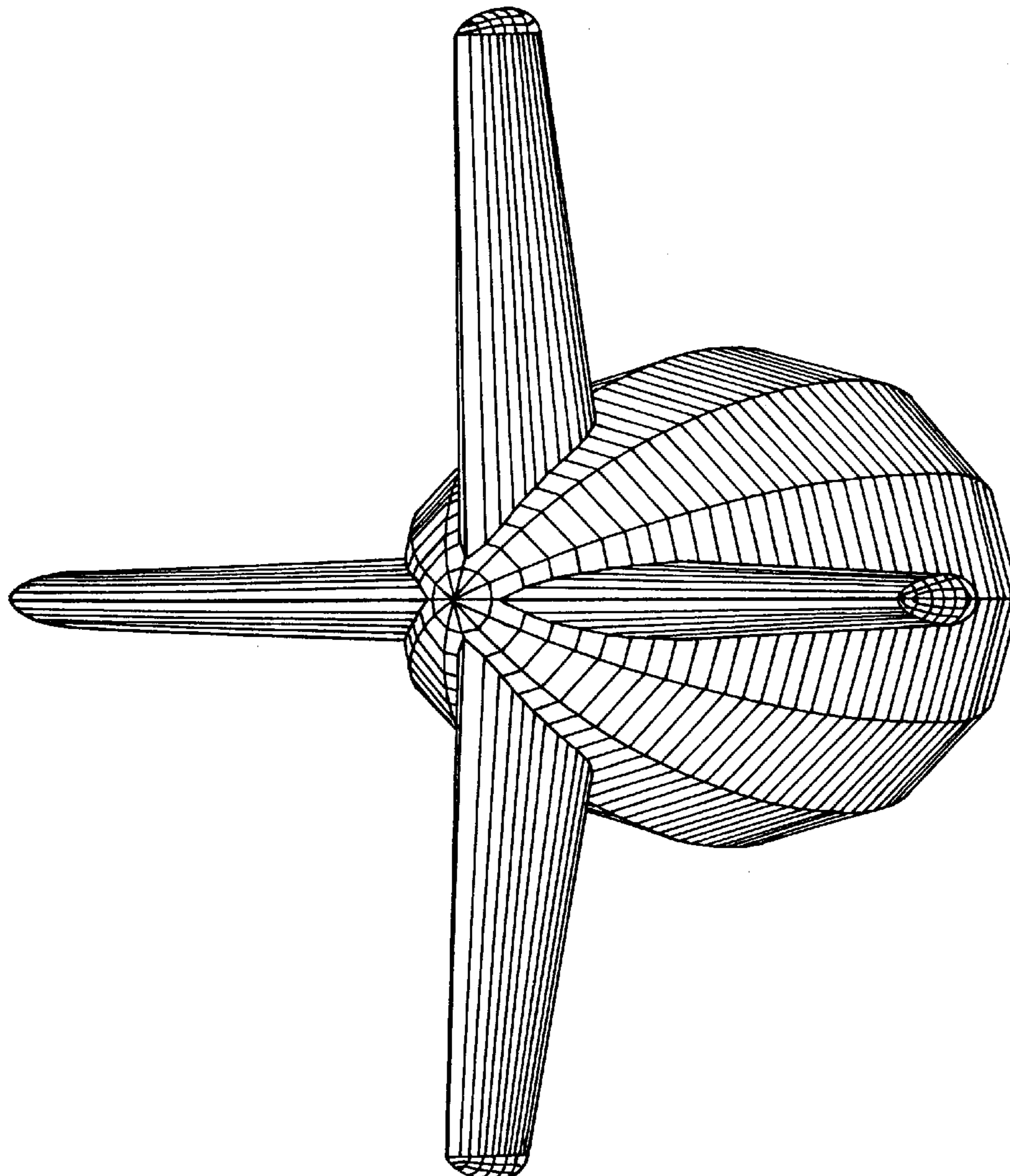

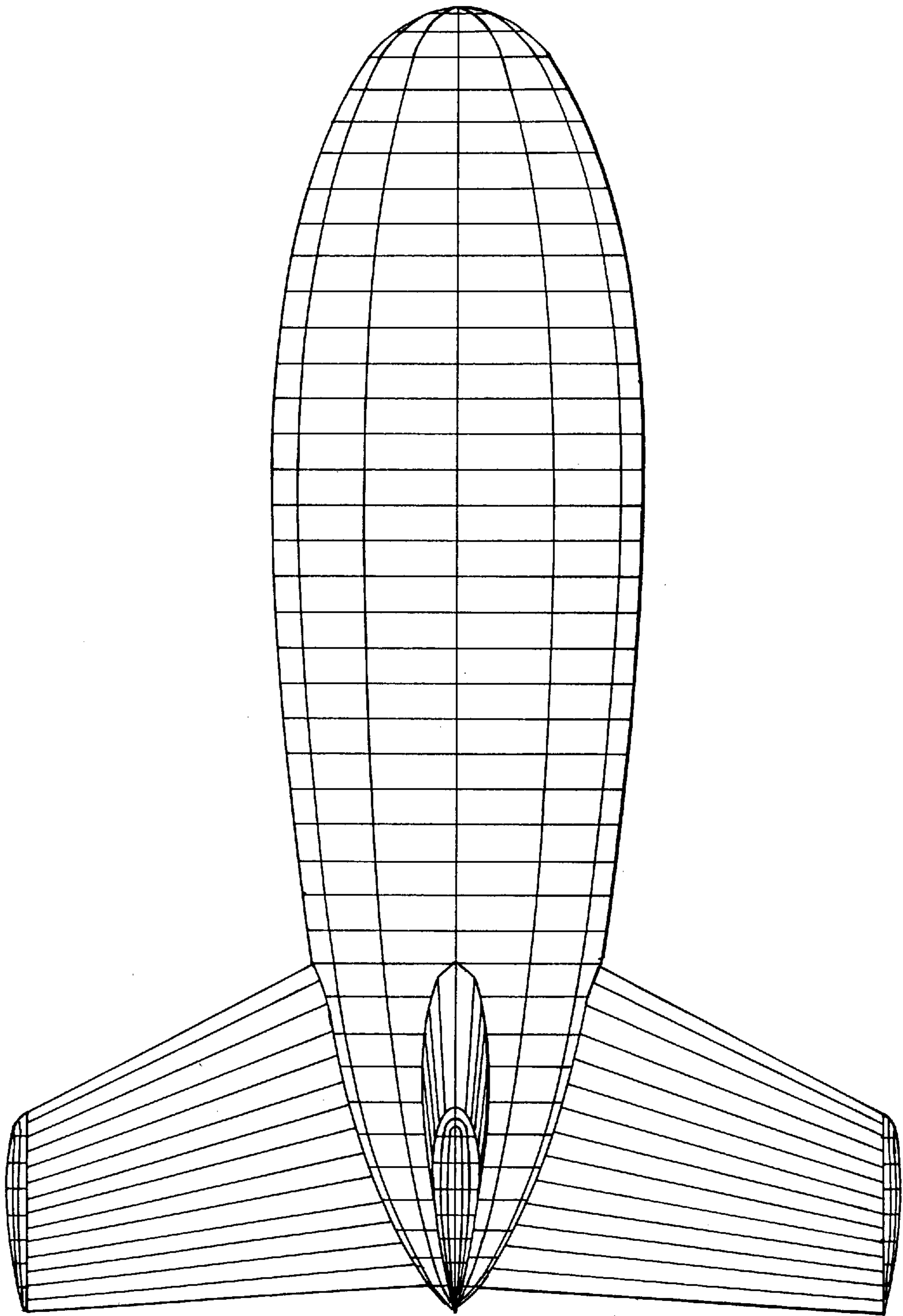

FIG. 1

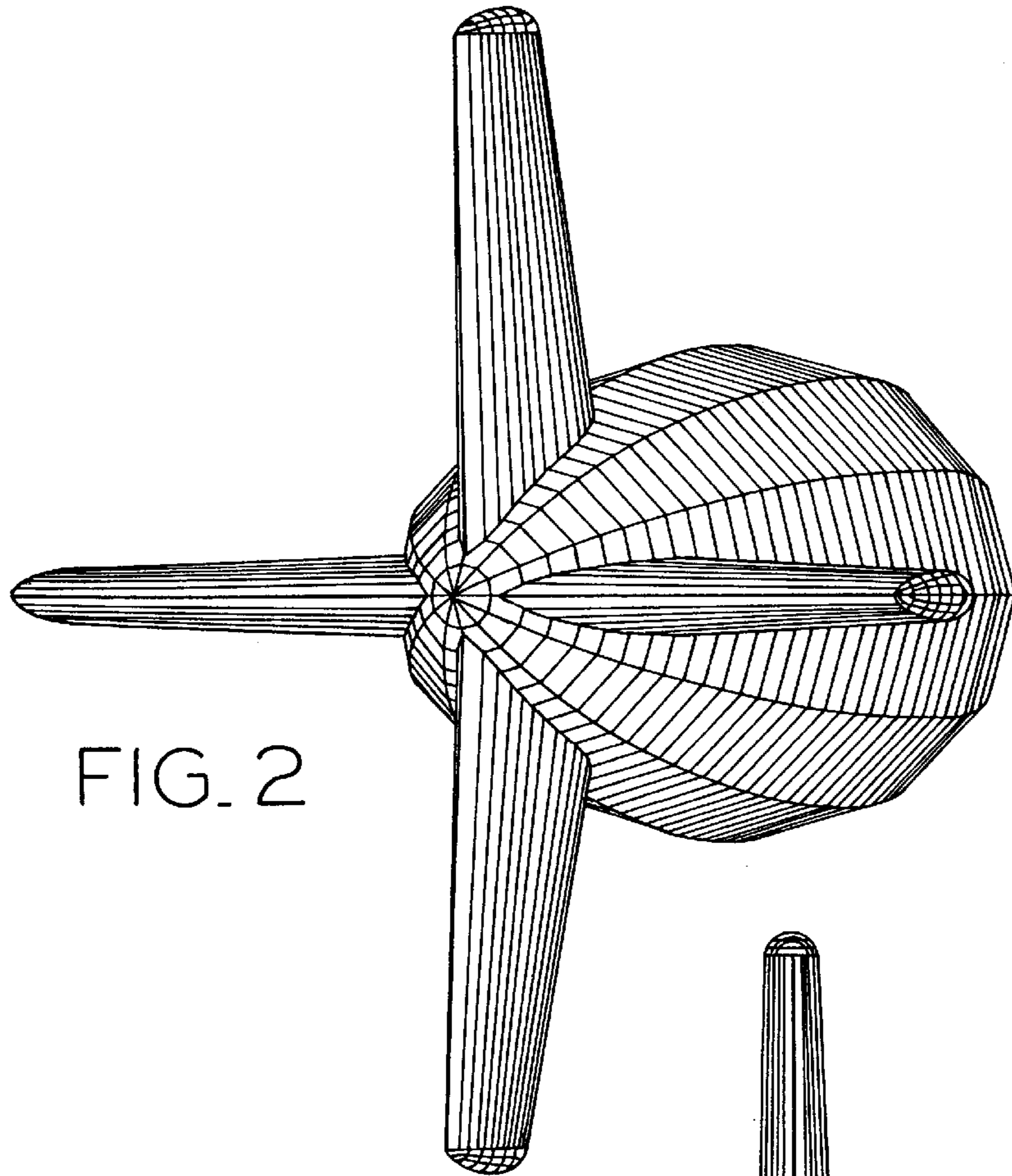

FIG. 2

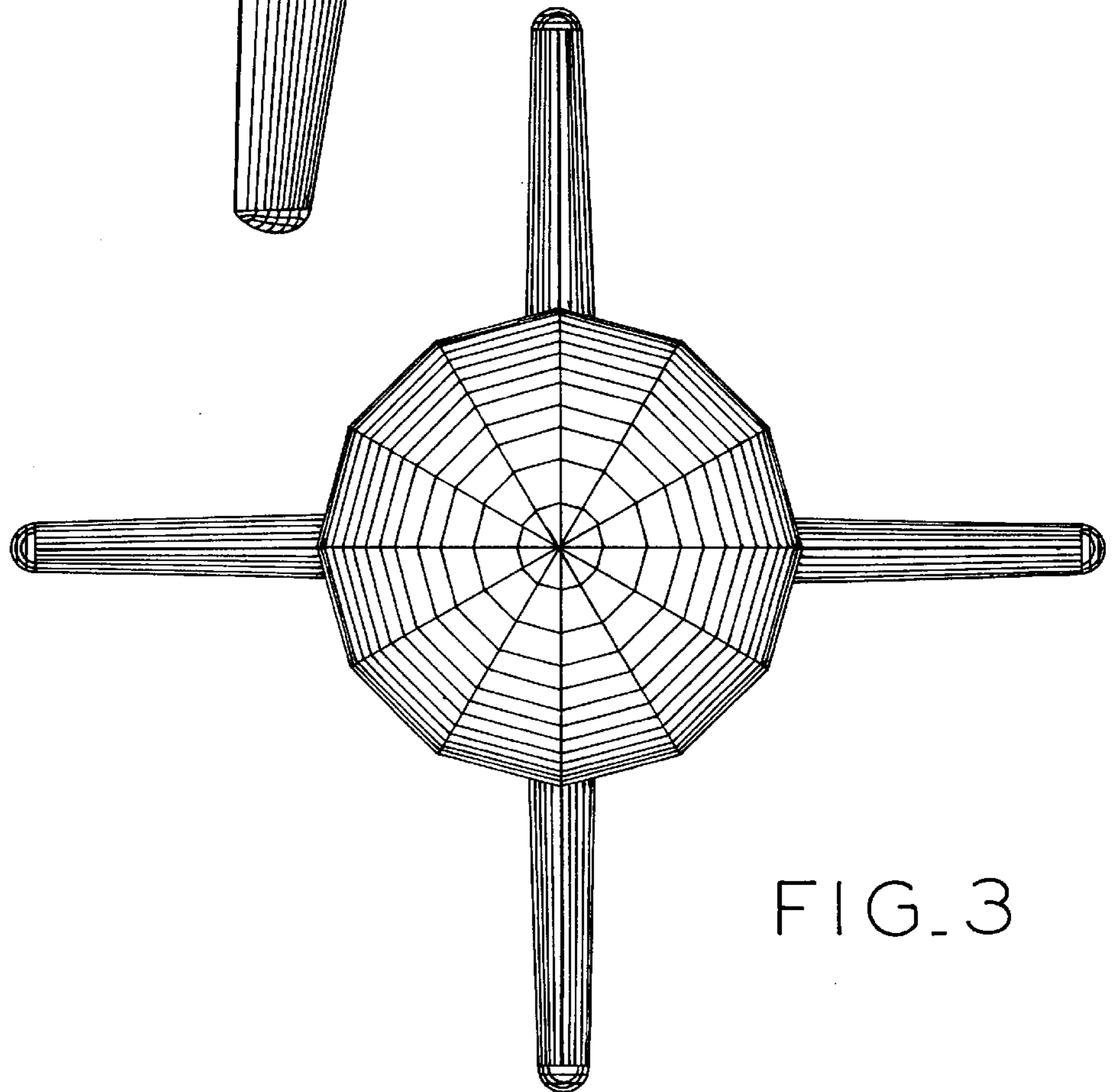

FIG. 3