



US00D399810S

United States Patent [19] Tucker

[11] **Patent Number: Des. 399,810**

[45] **Date of Patent: **Oct. 20, 1998**

[54] **AUTOMOBILE LAMP MONITORING PANEL**

[76] Inventor: **Robbie Dean Tucker**, 4943 Vecino Dr., Covina, Calif. 91722

[**] Term: **14 Years**

[21] Appl. No.: **62,336**

[22] Filed: **Nov. 13, 1996**

[51] **LOC (6) Cl. 12-16**

[52] **U.S. Cl. D12/192**

[58] **Field of Search** D12/192, 317, D12/415; D13/177, 134, 136, 147, 184, 164, 171; 200/1 R; 296/37.12, 70; 116/DIG. 5; 340/458, 635, 641; 362/32, 83.3

[56] **References Cited**

U.S. PATENT DOCUMENTS

D. 44,455 8/1913 Small D13/171

(List continued on next page.)

Primary Examiner—Robert M. Spear
Attorney, Agent, or Firm—Sheldon & Mak

[57] **CLAIM**

The ornamental design for an automobile lamp monitoring panel, as shown and described.

DESCRIPTION

FIG. 1 is a top left perspective view of the front of the automobile lamp monitoring panel with the fiberoptic cable-lamp connectors shown in broken lines;

FIG. 2 is a top left rear perspective view of the back side of the automobile lamp monitoring panel of FIG. 1 with the fiberoptic cable lamp connectors shown in broken lines;

FIG. 3 is front elevation view of the automobile lamp monitoring panel of FIG. 1 with the fiberoptic cable lamp connectors shown in broken lines;

FIG. 4 is a rear elevation view of the automobile lamp monitoring panel of FIG. 1 with the fiberoptic cable lamp connectors shown in broken lines;

FIG. 5 is a left side elevation view of the automobile lamp monitoring panel of FIG. 1 with the fiberoptic cable lamp connectors shown in broken lines;

FIG. 6 is a right side elevation view of the automobile lamp monitoring panel of FIG. 1 with the fiberoptic cable lamp connectors shown in broken lines;

FIG. 7 is a top right perspective view of the indicator lens mounting of the automobile lamp monitoring panel of FIG. 1 removed from the mounting plate and with the fiberoptic cable lamp connectors shown in broken lines;

FIG. 8 is a top right perspective of the view of the monitoring plate with the indicator lens mounting removed for the automobile lamp monitoring panel of FIG. 1 and shown with the fiberoptic cable lamp connectors removed for ease of disclosure;

FIG. 9 is a bottom left perspective view of the front of a four lamp indicator of the automobile lamp monitoring panel of FIG. 1 shown removed from the indicator mounting plate and with the fiberoptic cable connectors shown in broken lines;

FIG. 10 is a front elevation view of a four lamp indicator lens mounting of the automobile lamp monitoring panel of FIG. 1 shown removed from the indicator lens mounting plate and showing the fiberoptic cable lamp connector removed for ease of disclosure;

FIG. 11 is a rear elevation view of a four lamp indicator lens mounting of the of the automobile lamp monitoring panel of FIG. 1 shown removed from the indicator lens mounting plate and showing the fiberoptic cable lamp connectors removed for ease of disclosure;

FIG. 12 is a bottom left perspective view of the front of a five lamp indicator lens mounting for the automobile lamp monitoring panel of FIG. 1 removed from the mounting plate and with the fiberoptic cable lamp connectors shown in broken lines;

FIG. 13 is a front elevation view of the five lamp indicator of lens mounting for the automobile lamp monitoring panel of FIG. 1 shown removed from the mounting plate with the fiberoptic cable lamp connectors removed for ease of disclosure; and,

FIG. 14 is a rear elevation view of the five lamp indicator lens mounting of FIG. 12 for the automobile lamp monitoring panel of FIG. 1 shown removed from the mounting plate with the fiberoptic cable lamp connectors shown removed for ease of disclosure.

The broken line showing of fiber optic cable connectors is for illustrative purposes only and forms no part of the claimed design.

1 Claim, 4 Drawing Sheets

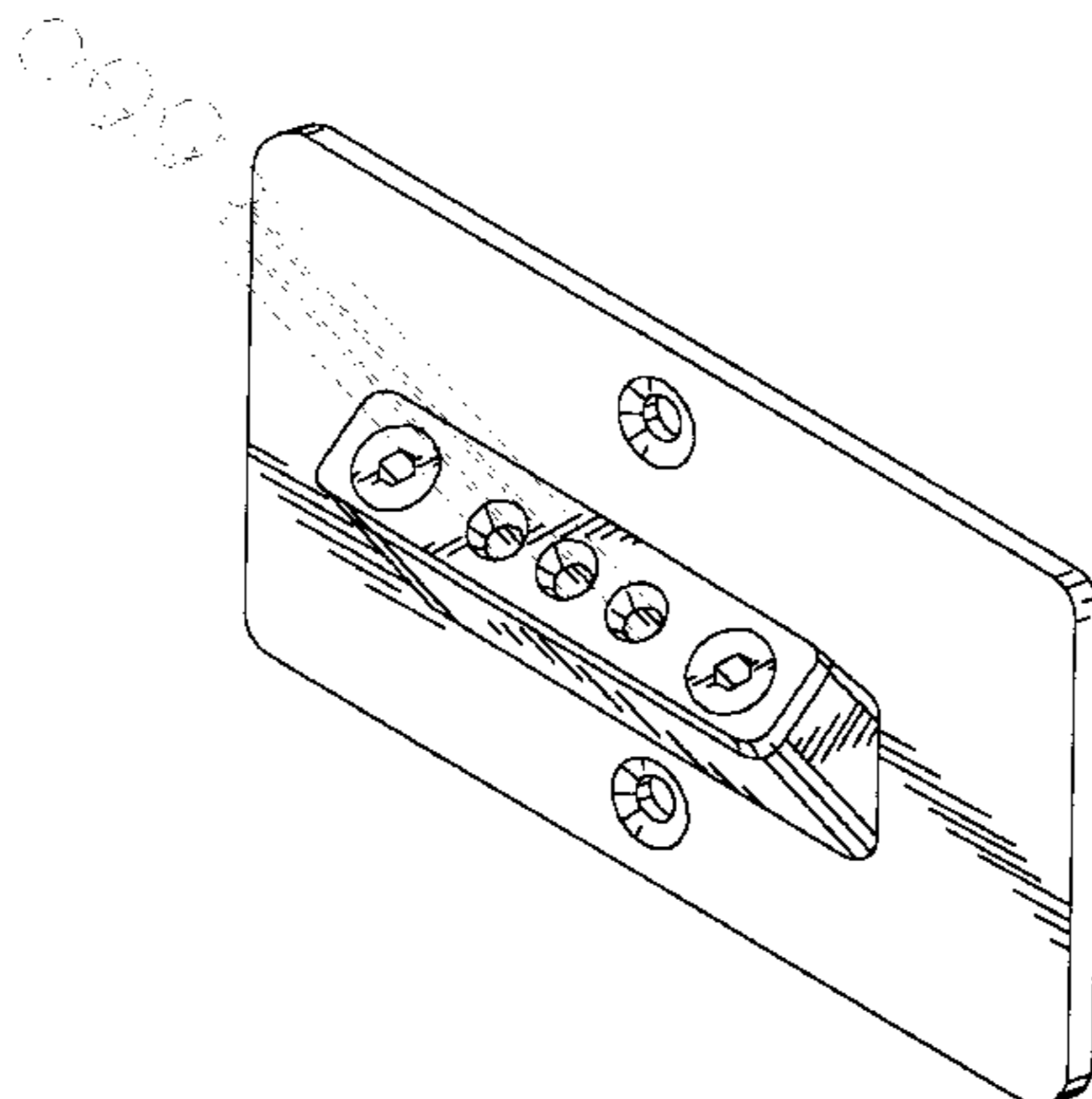

Des. 399,810

Page 2

U.S. PATENT DOCUMENTS

D. 228,127	8/1973	Fernandez et al.	D12/192	D. 373,997	9/1996	Kopser	D13/164
D. 272,821	2/1984	Perethian	D13/171	D. 384,647	10/1997	Kopser	D13/171
D. 302,424	7/1989	Solon et al.	D13/164	2,437,777	3/1948	Zajc	200/1 R
D. 310,818	9/1990	Zaretsky et al.	D13/171	2,736,014	2/1956	Goedderz	340/458
D. 361,059	8/1995	DeWaal	D13/177	4,652,706	3/1987	Rao et al.	200/1 R
				4,684,164	8/1987	Durham	296/37.12
				4,743,714	5/1988	Chien	200/1 R

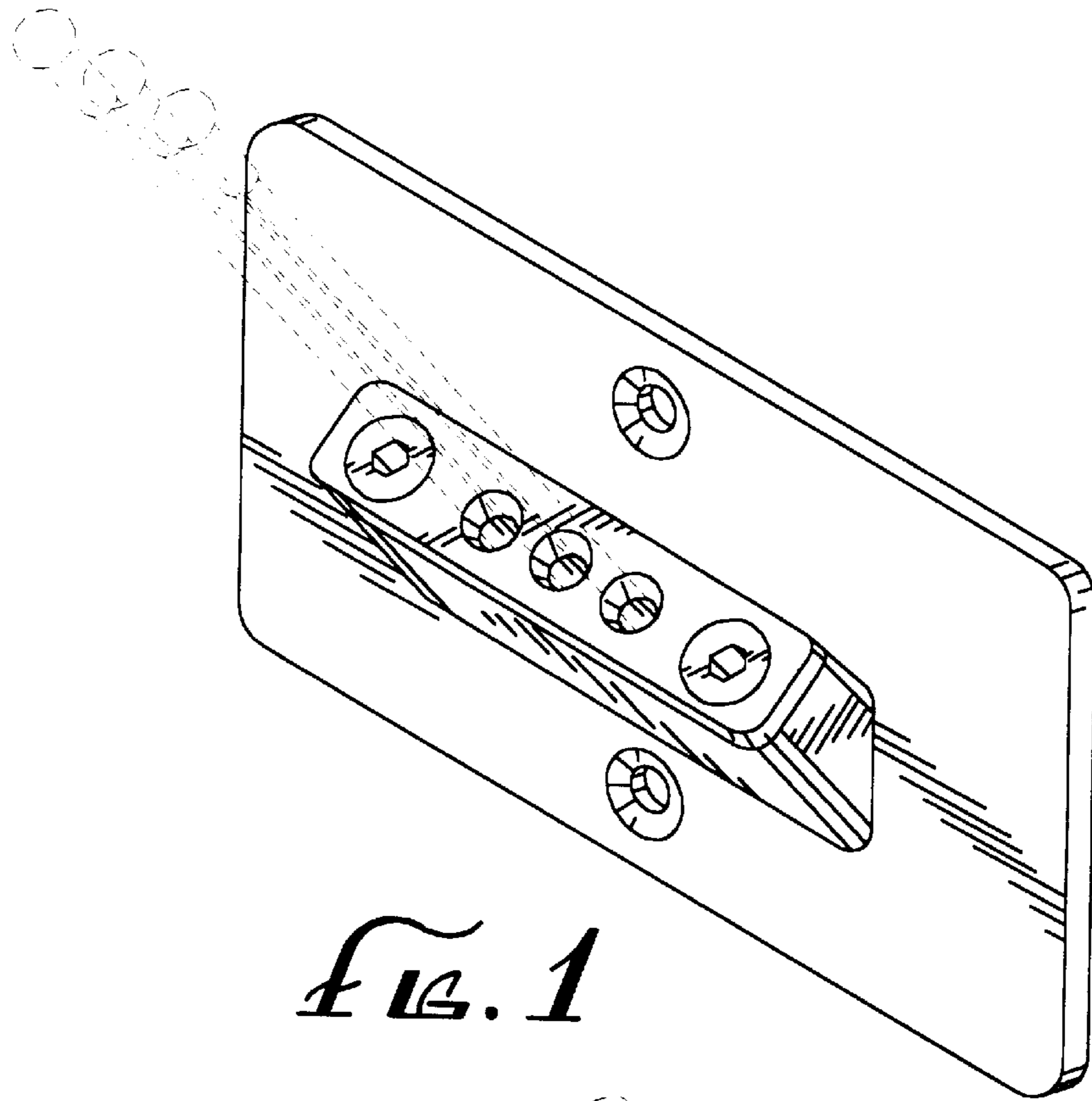

FIG. 1

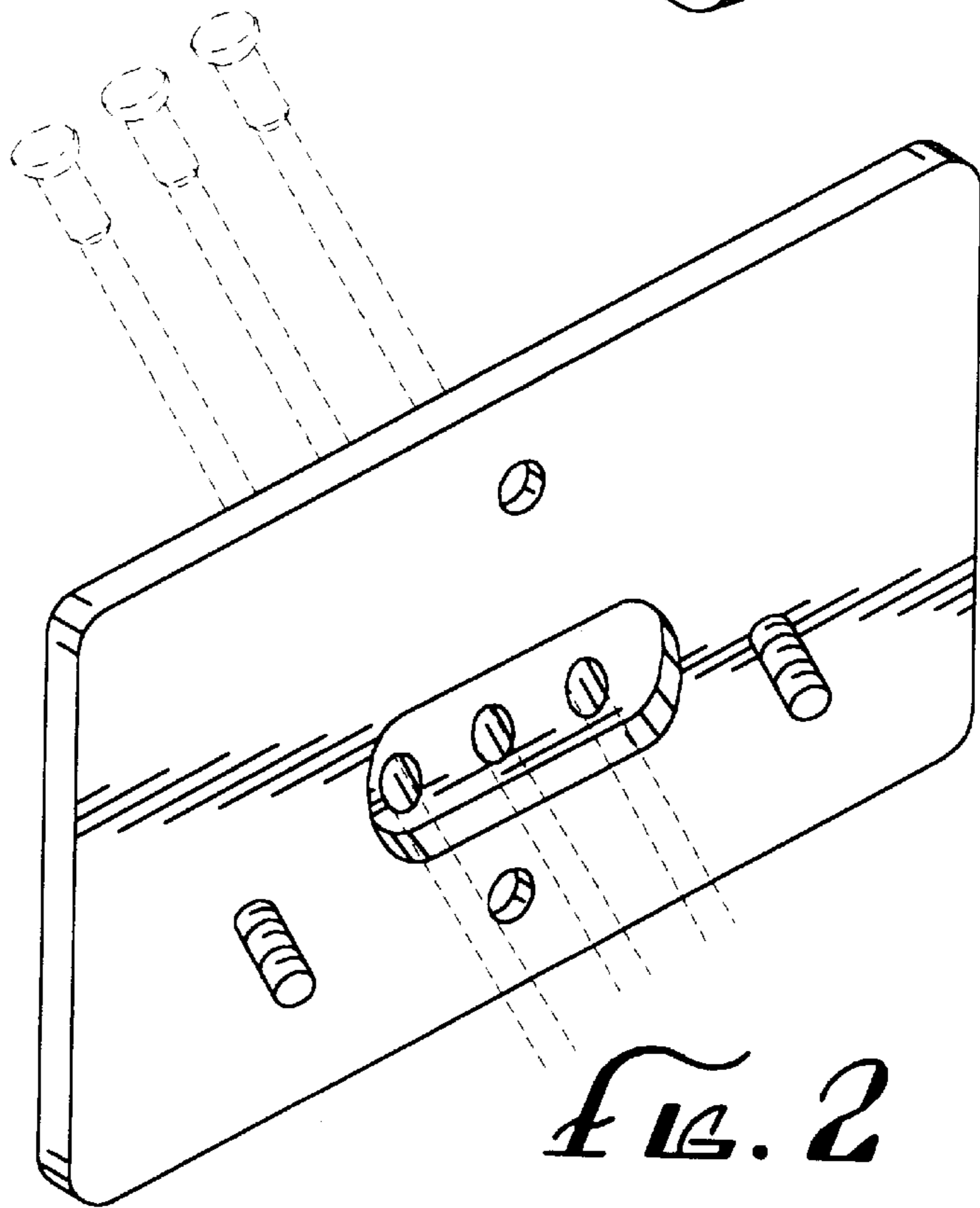

FIG. 2

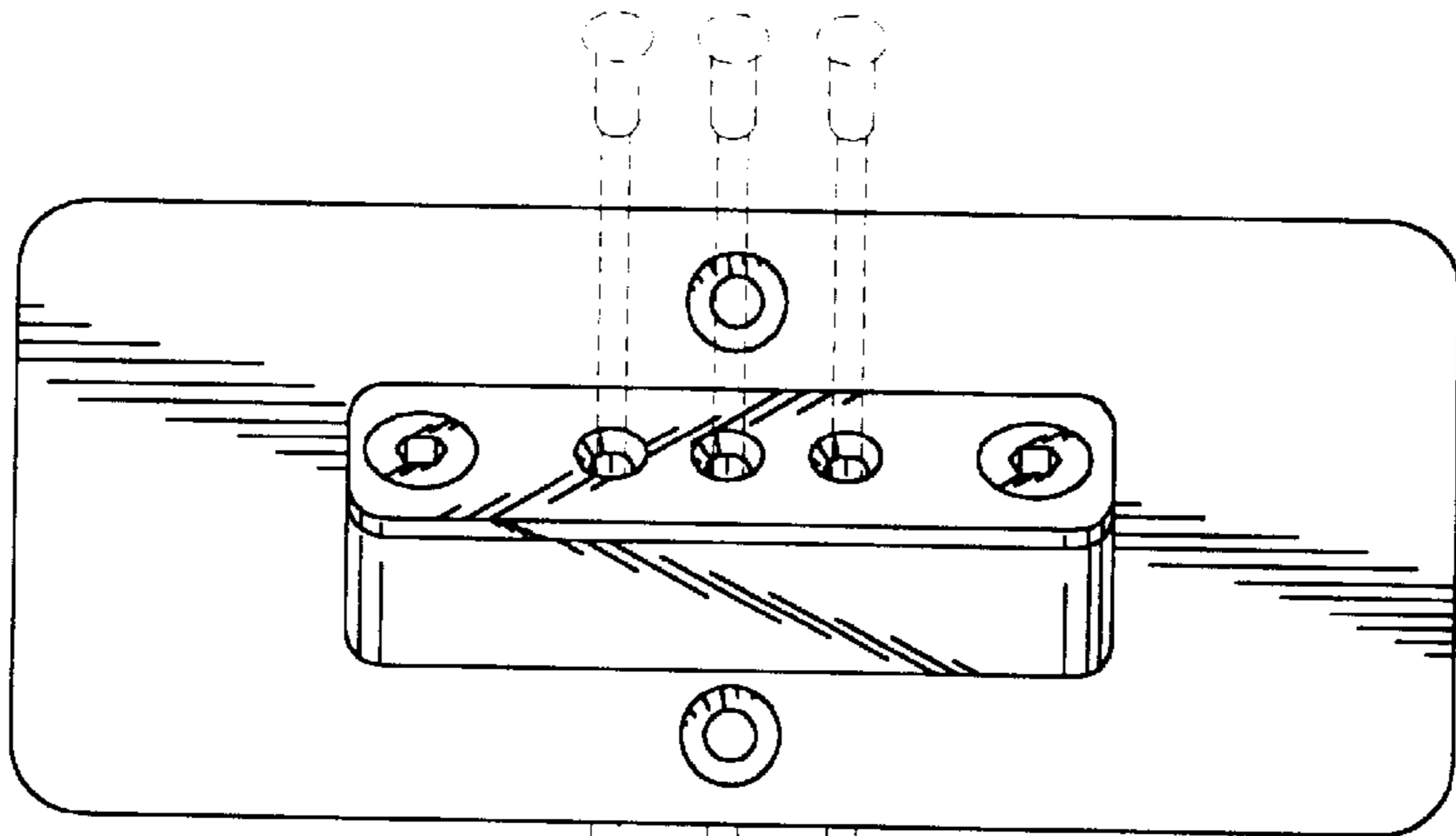

FIG. 3

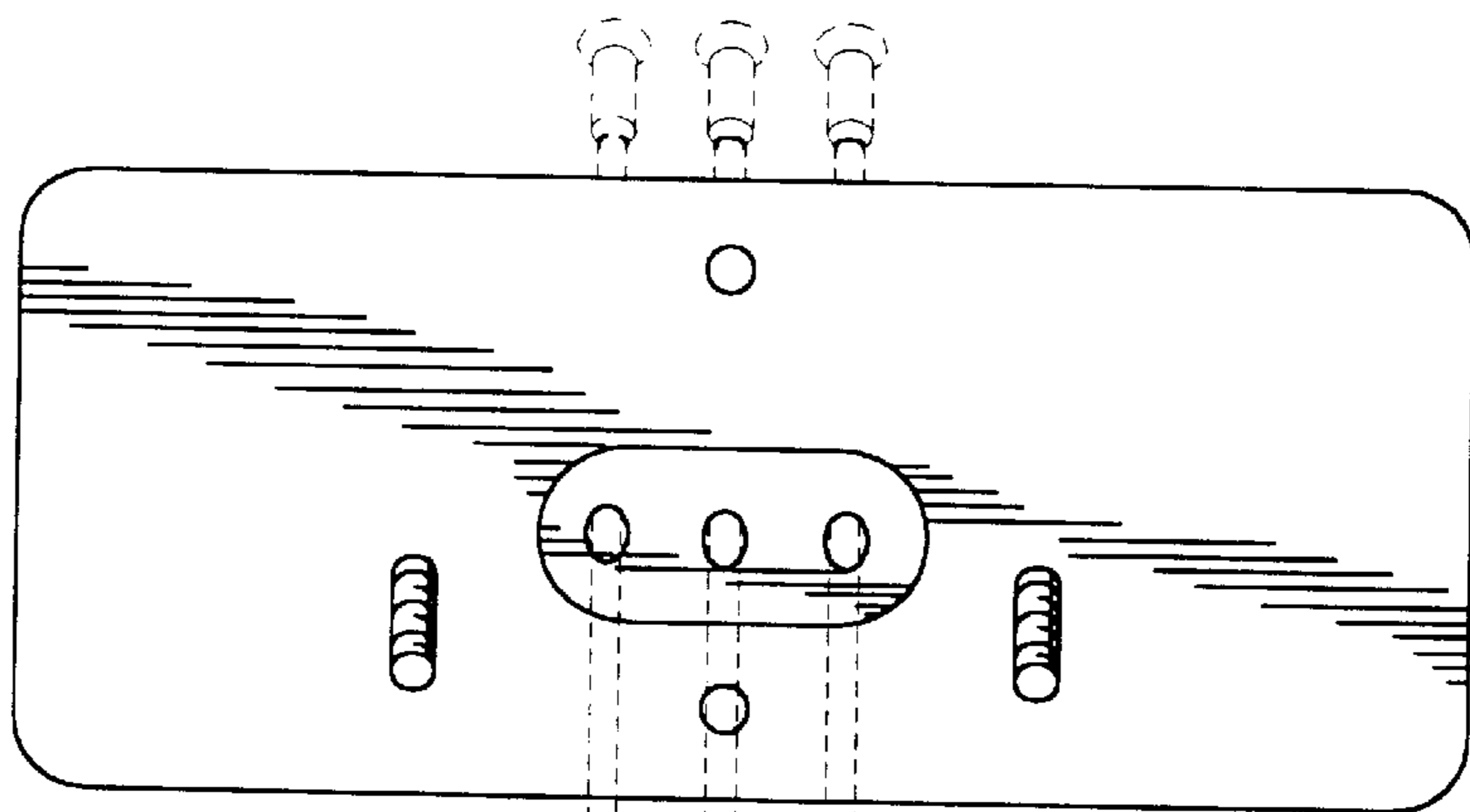

FIG. 4

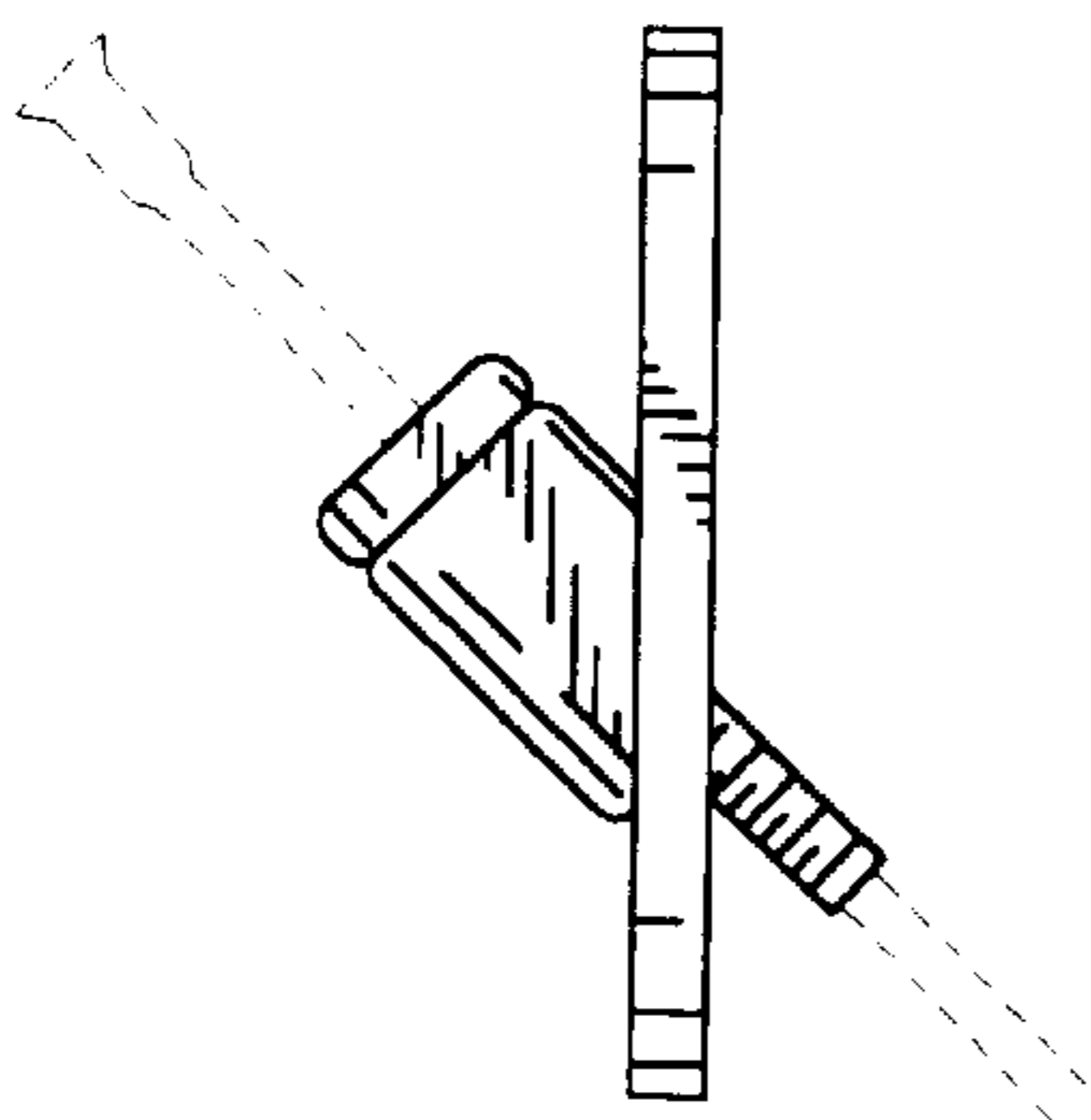

FIG. 5

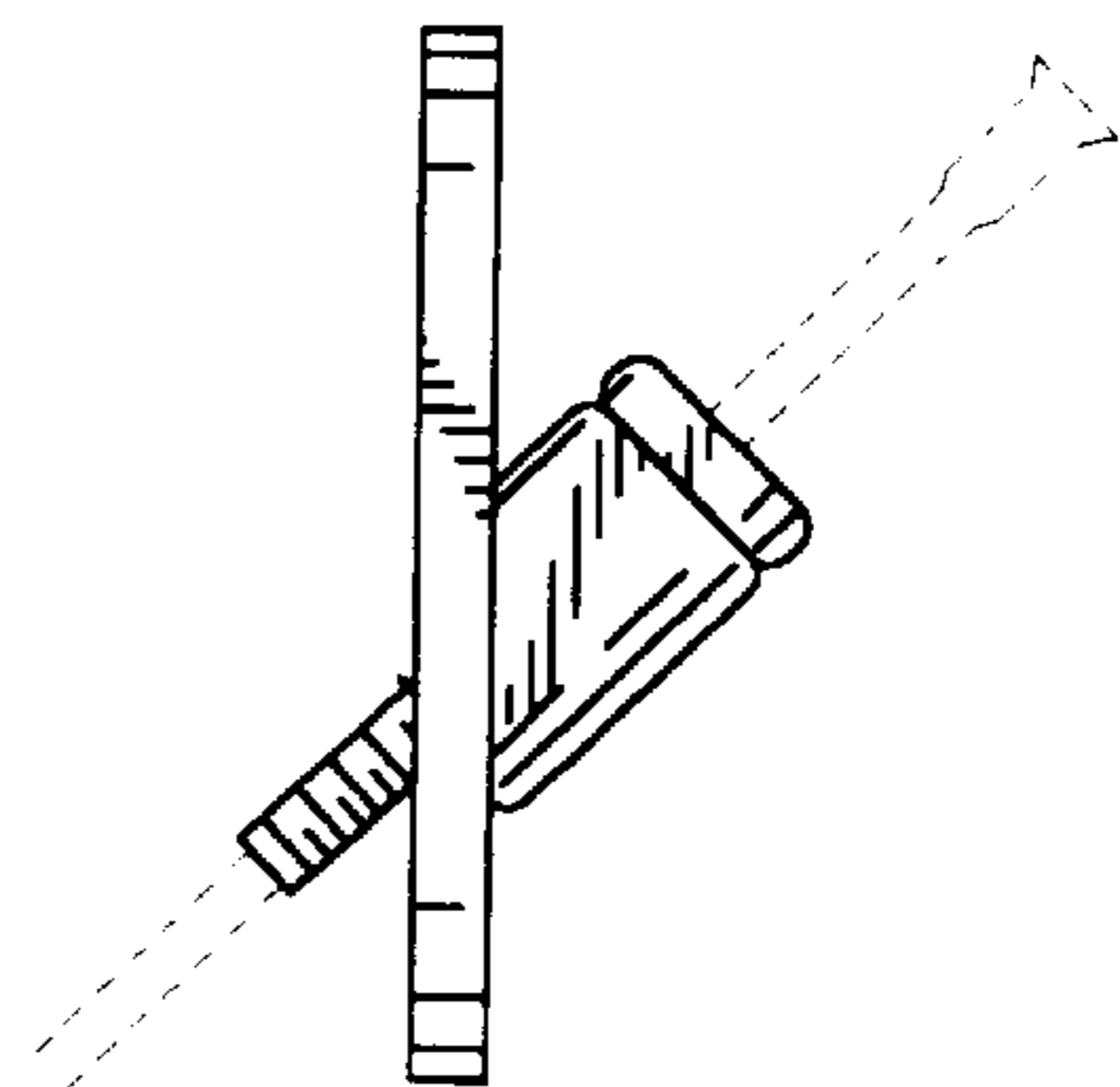

FIG. 6

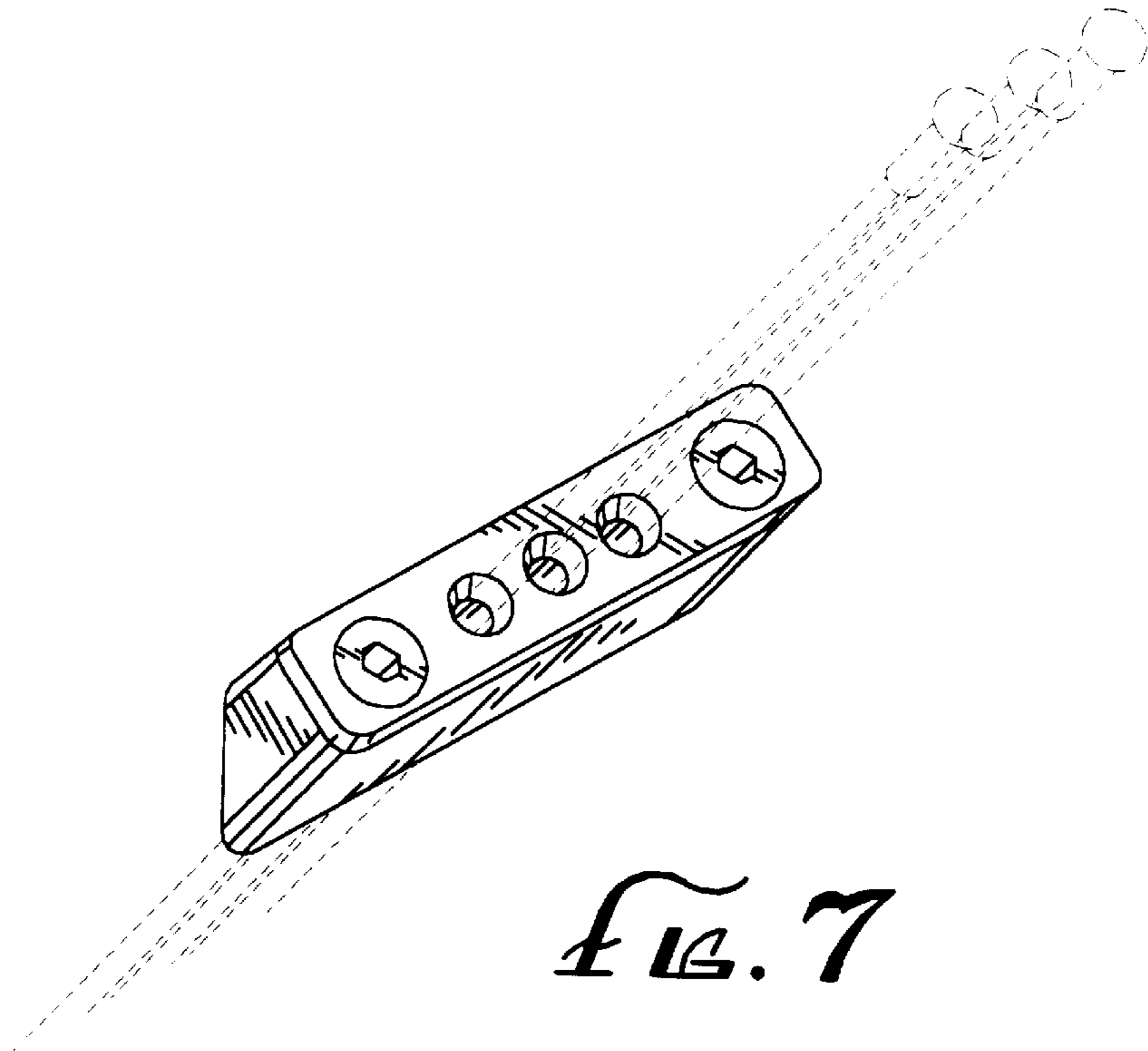

FIG. 7

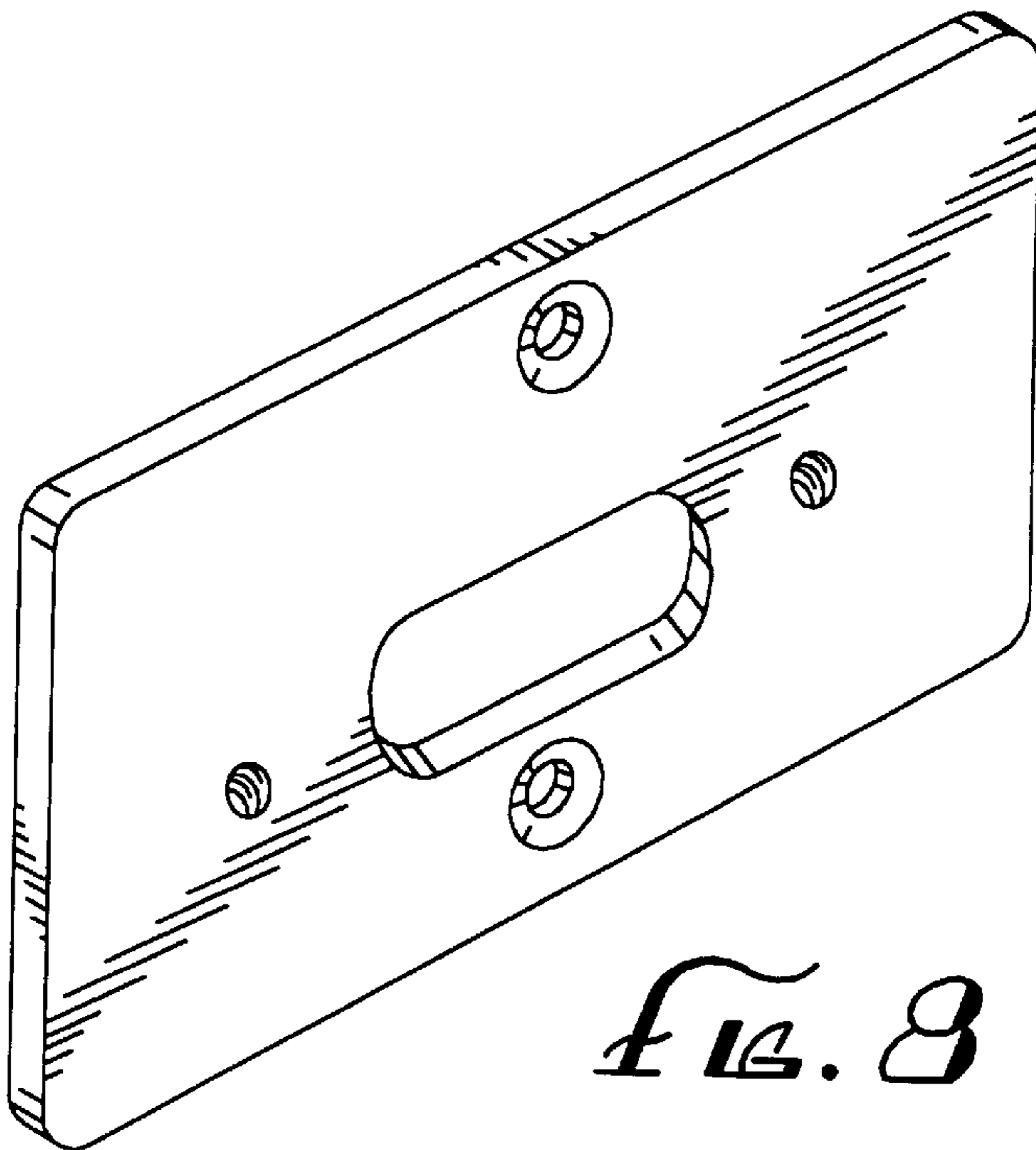

FIG. 8

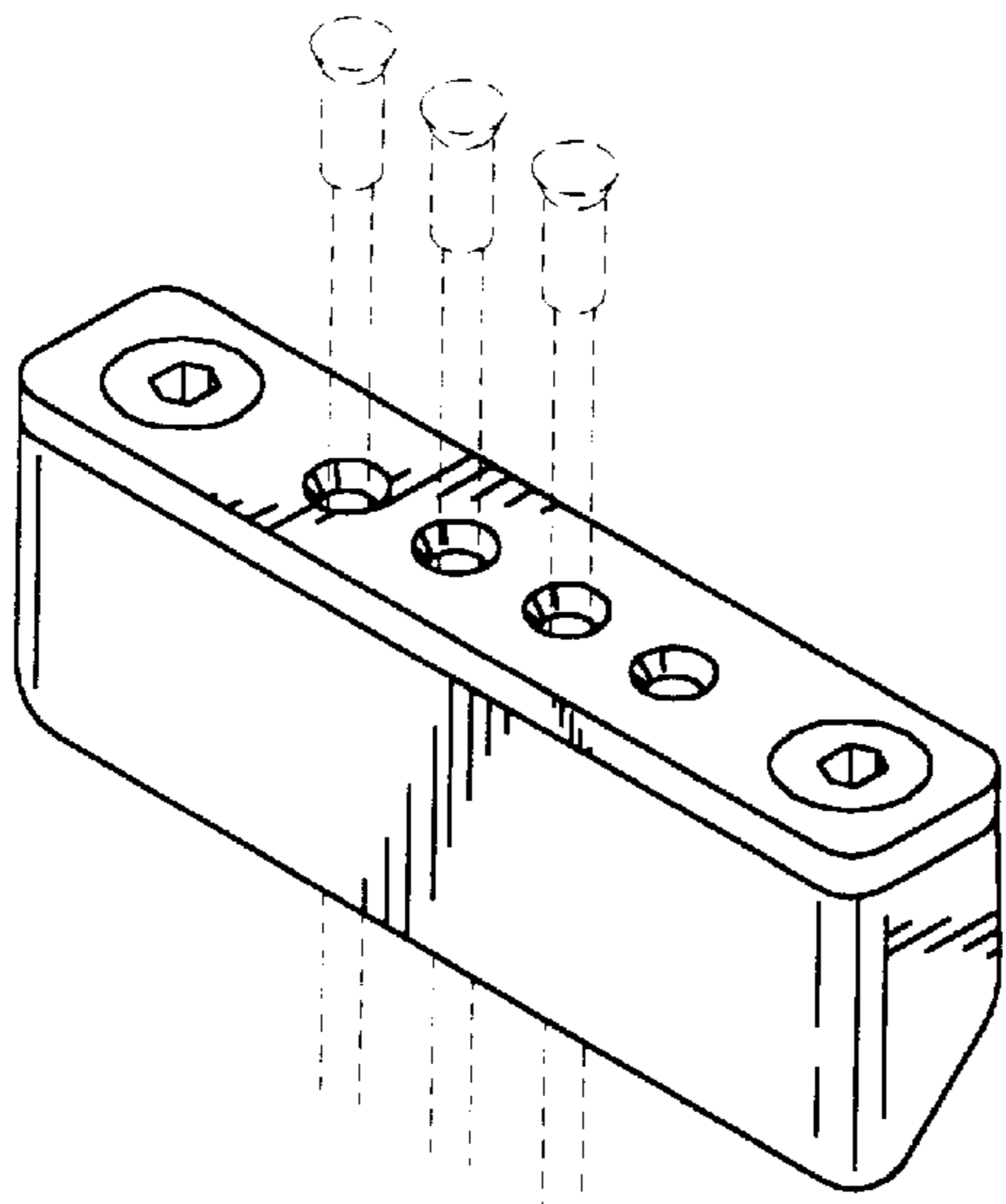

FIG. 9

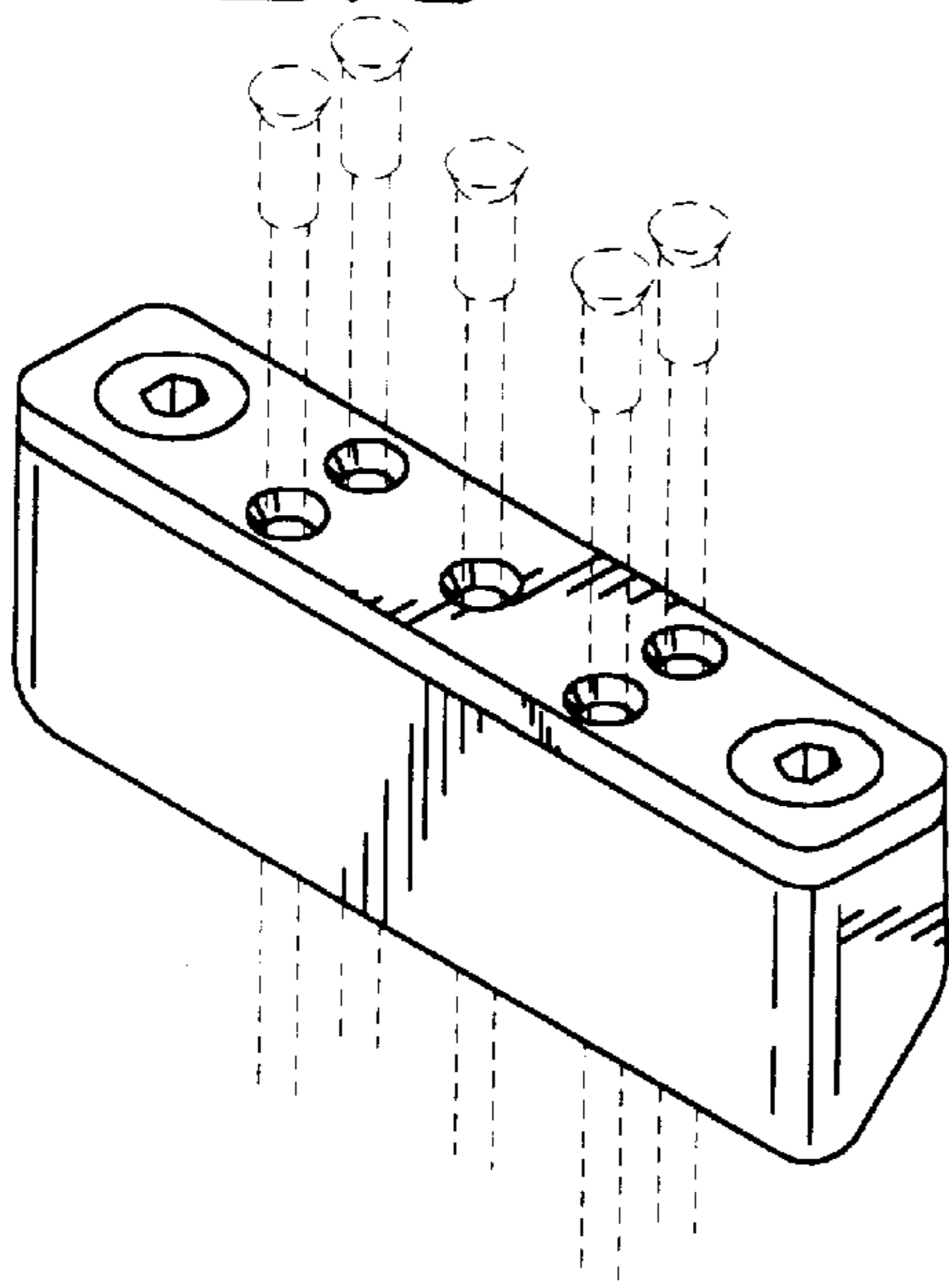

FIG. 12

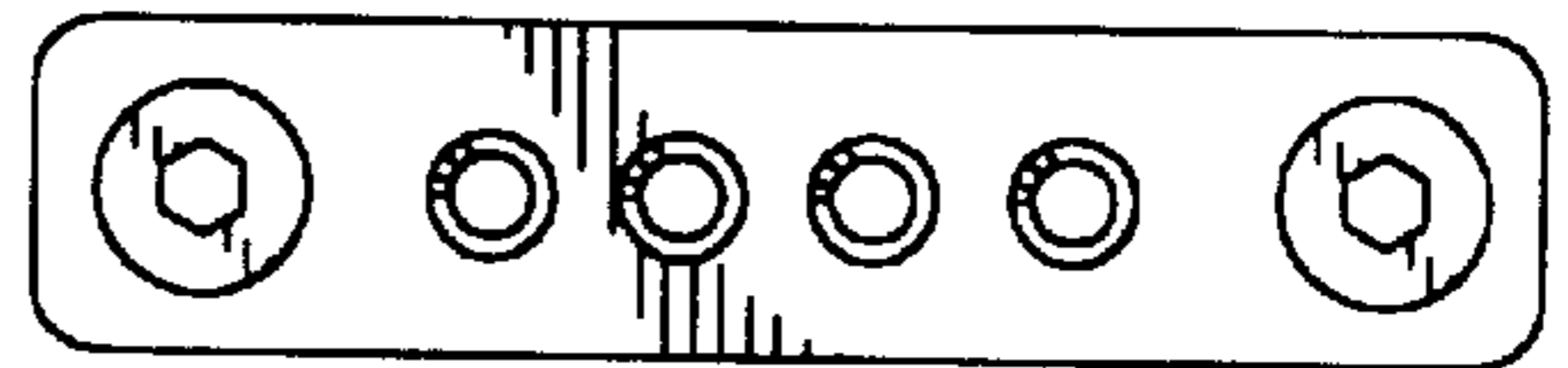

FIG. 10

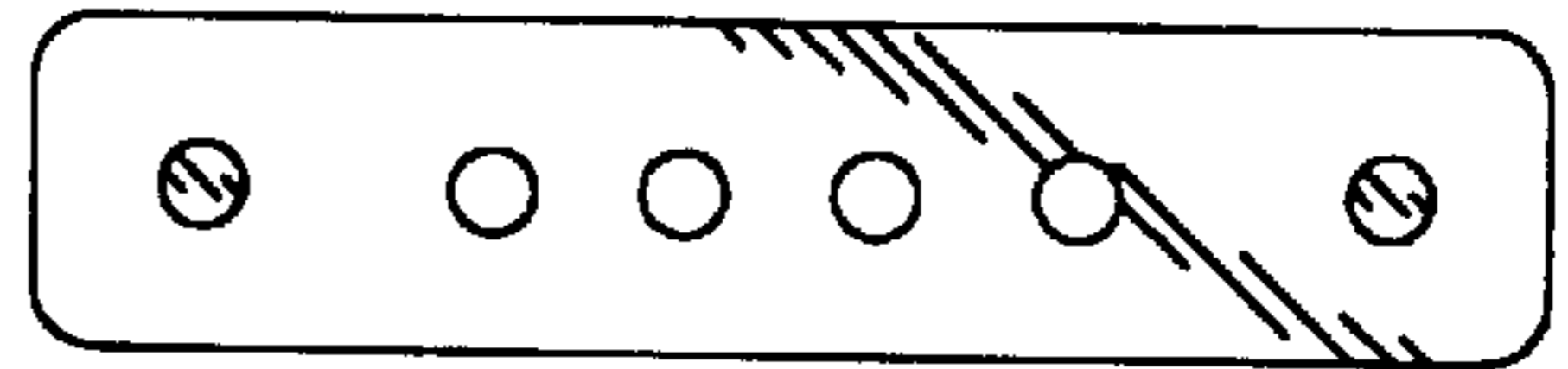

FIG. 11

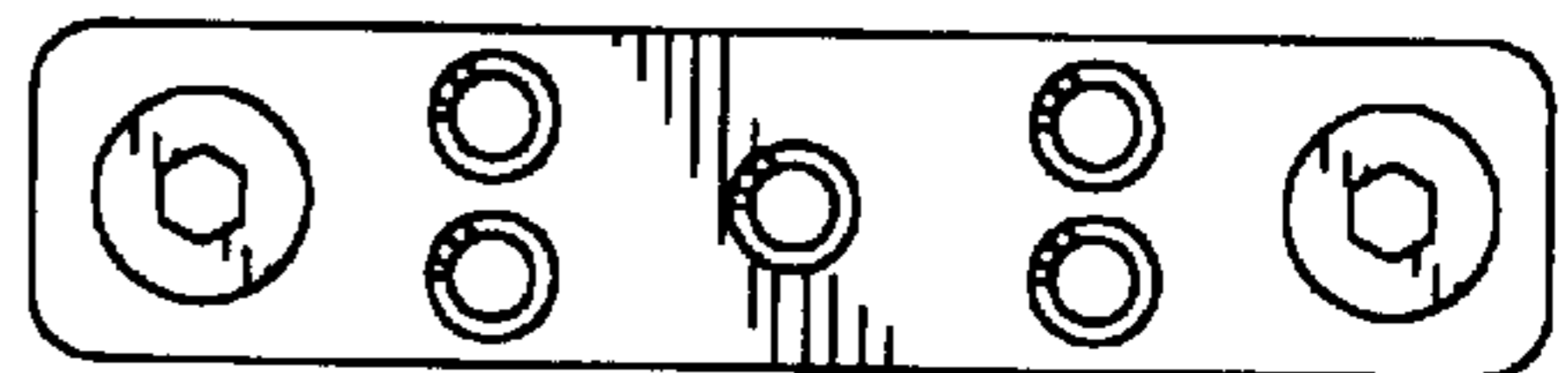

FIG. 13

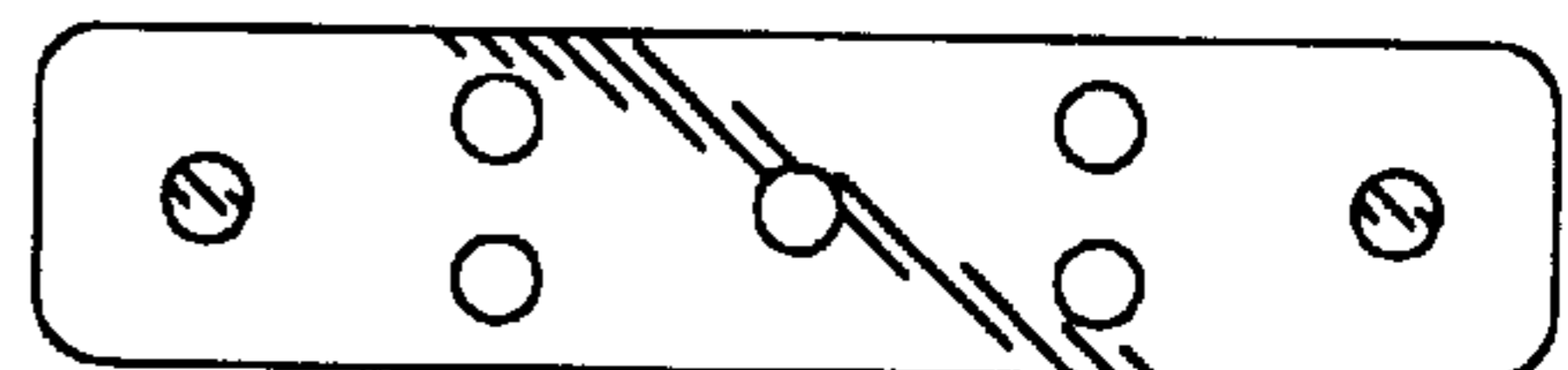

FIG. 14