



US00D399790S

United States Patent [19]

Boniface et al.

[11] Patent Number: **Des. 399,790**

[45] Date of Patent: ****Oct. 20, 1998**

[54] **VEHICLE BODY**

[75] Inventors: **Robert E. Boniface**, Royal Oak; **John D. Bucci**, Rochester; **David C. McKinnon**, Birmingham; **K. Neil Walling**, Leonard, all of Mich.

[73] Assignee: **Chrysler Corporation**, Auburn Hills, Mich.

[**] Term: **14 Years**

[21] Appl. No.: **45,837**

[22] Filed: **Oct. 31, 1995**

[51] **LOC (6) Cl.** **12-08**

[52] **U.S. Cl.** **D12/92**

[58] **Field of Search** D12/90-92; 296/185

[56] **References Cited**

U.S. PATENT DOCUMENTS

D. 294,337	2/1988	Reed et al.	D12/90
D. 326,435	5/1992	Park	D12/92
D. 345,324	3/1994	Bucci et al.	D12/92
D. 346,771	5/1994	Verduyn	D12/92
D. 351,124	10/1994	Dehner et al.	D12/92
D. 370,646	6/1996	Verduyn	D12/91

OTHER PUBLICATIONS

Motor Trend, Jul. 1988, p. 9, Nissan Silvia, Bottom of page.
Road & Track, Apr. 1990, p. 91, Eagle Optima Automobile, Top of Page.

Road & Track, Dec. 1991, p. 50, Ford Sierra Fastback Automobile, Third Photograph Down From Top Right Side of Page.

Primary Examiner—Melody N. Brown
Attorney, Agent, or Firm—Mark P. Calcaterra

[57] **CLAIM**

The ornamental design for a vehicle body, as shown and described.

DESCRIPTION

FIG. 1 is a front perspective view of a vehicle body showing our new design;

FIG. 2 is a rear perspective view thereof;

FIG. 3 is a left side view thereof, it being understood that the side opposite to that shown is a substantial mirror image thereof;

FIG. 4 is a front view thereof; and,

FIG. 5 is a rear view thereof.

It will be understood that the broken line showing throughout the drawings is for illustrative purposes only and forms no part of the subject design.

1 Claim, 4 Drawing Sheets

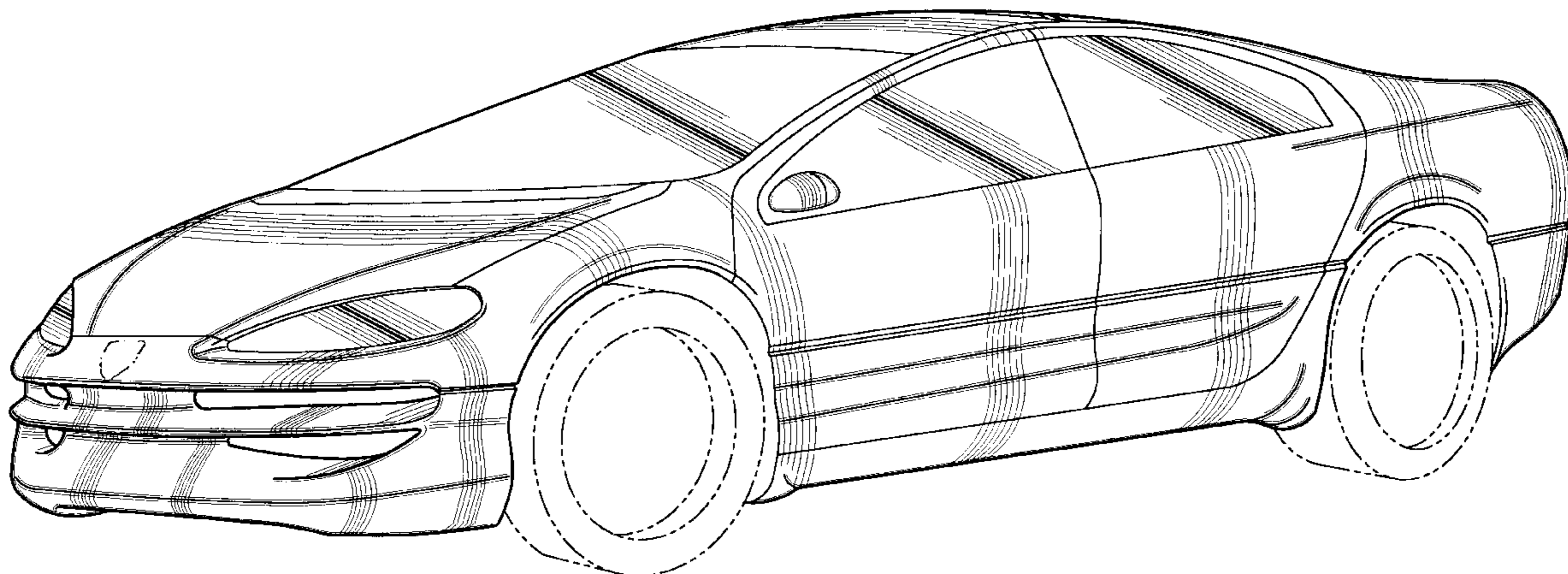

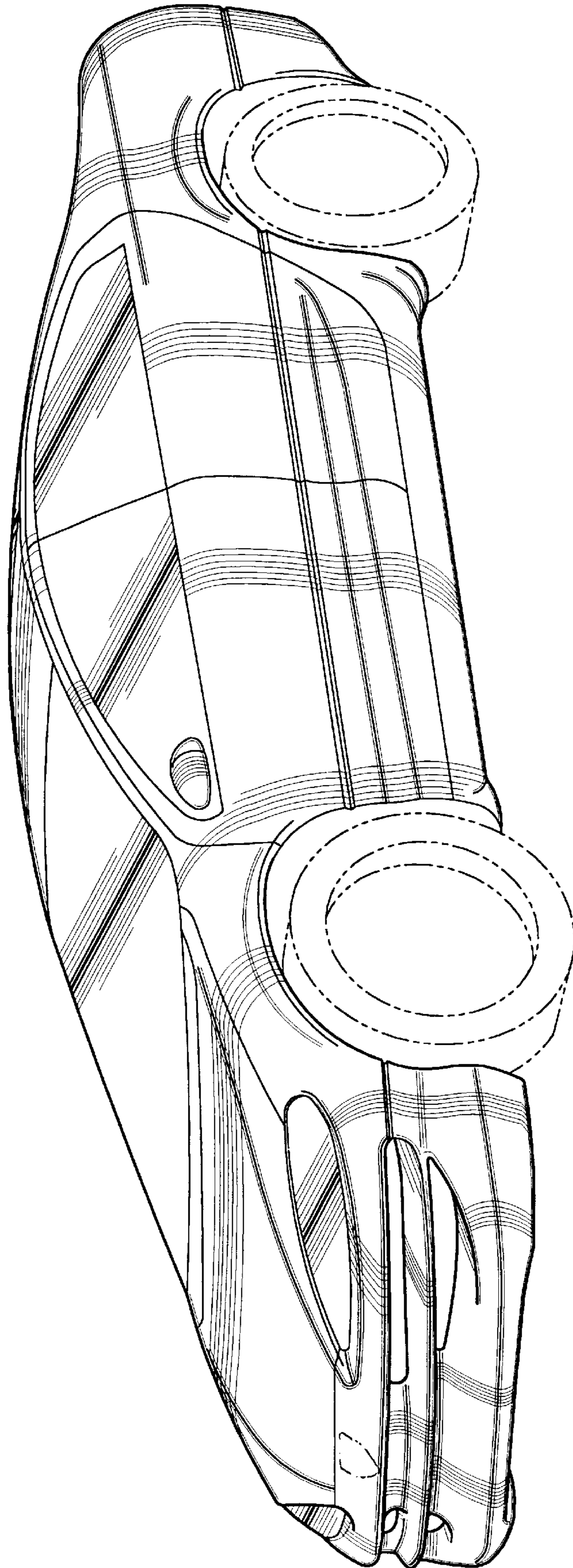

Fig-1

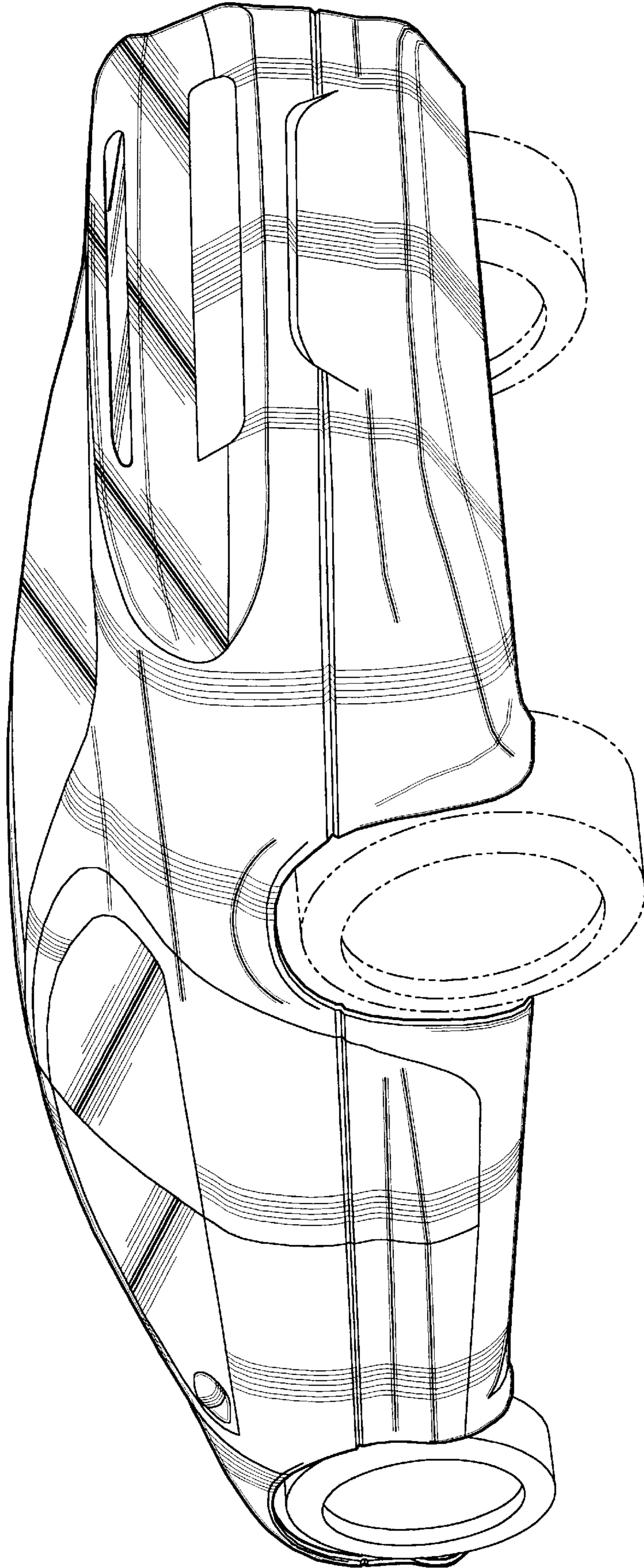

Fig-2

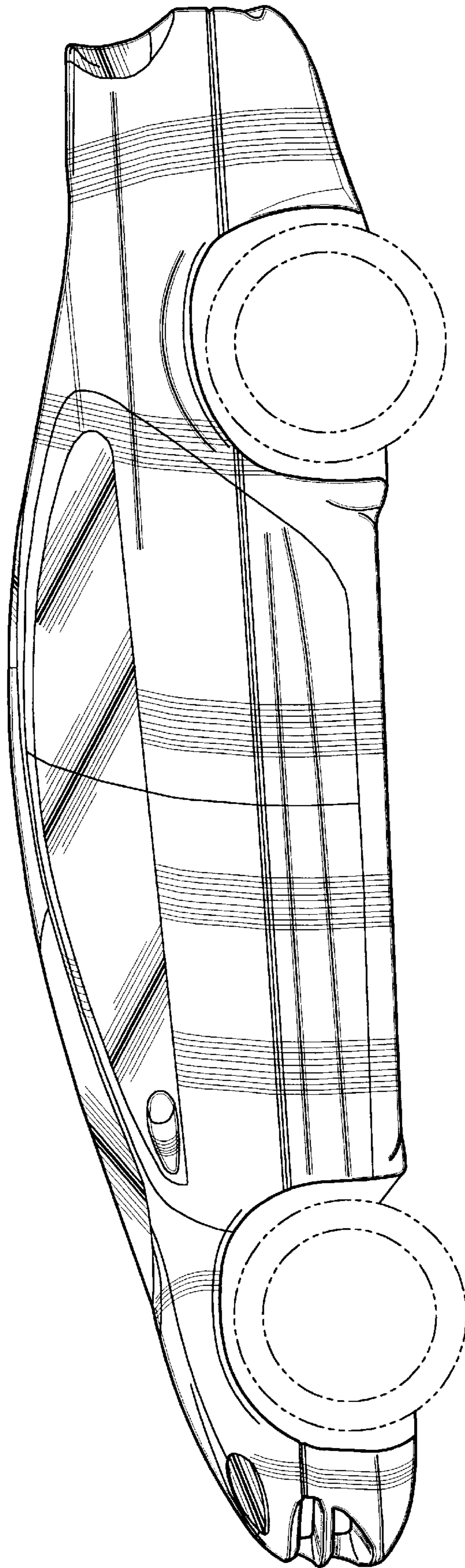

Fig-3

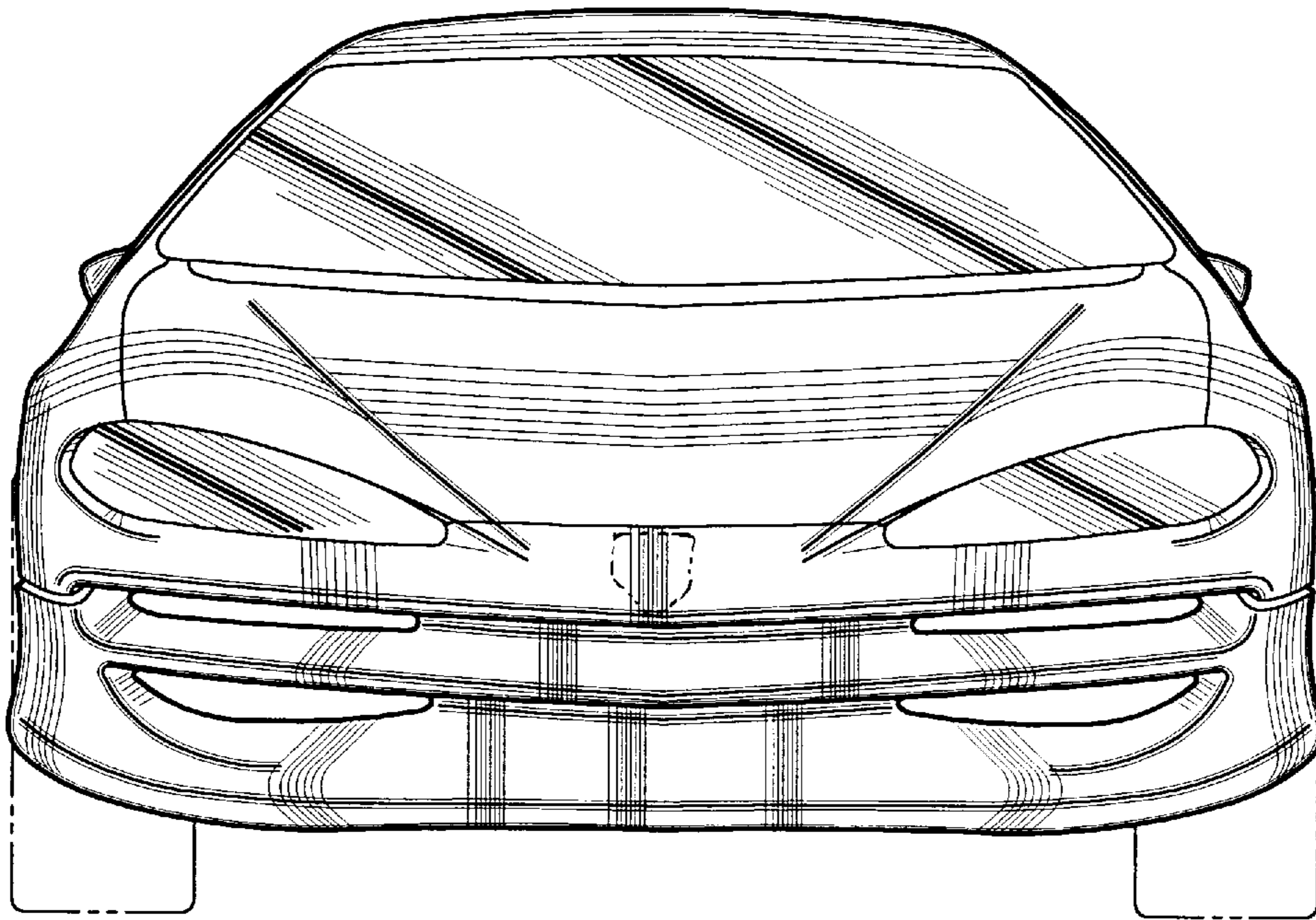

Fig-4

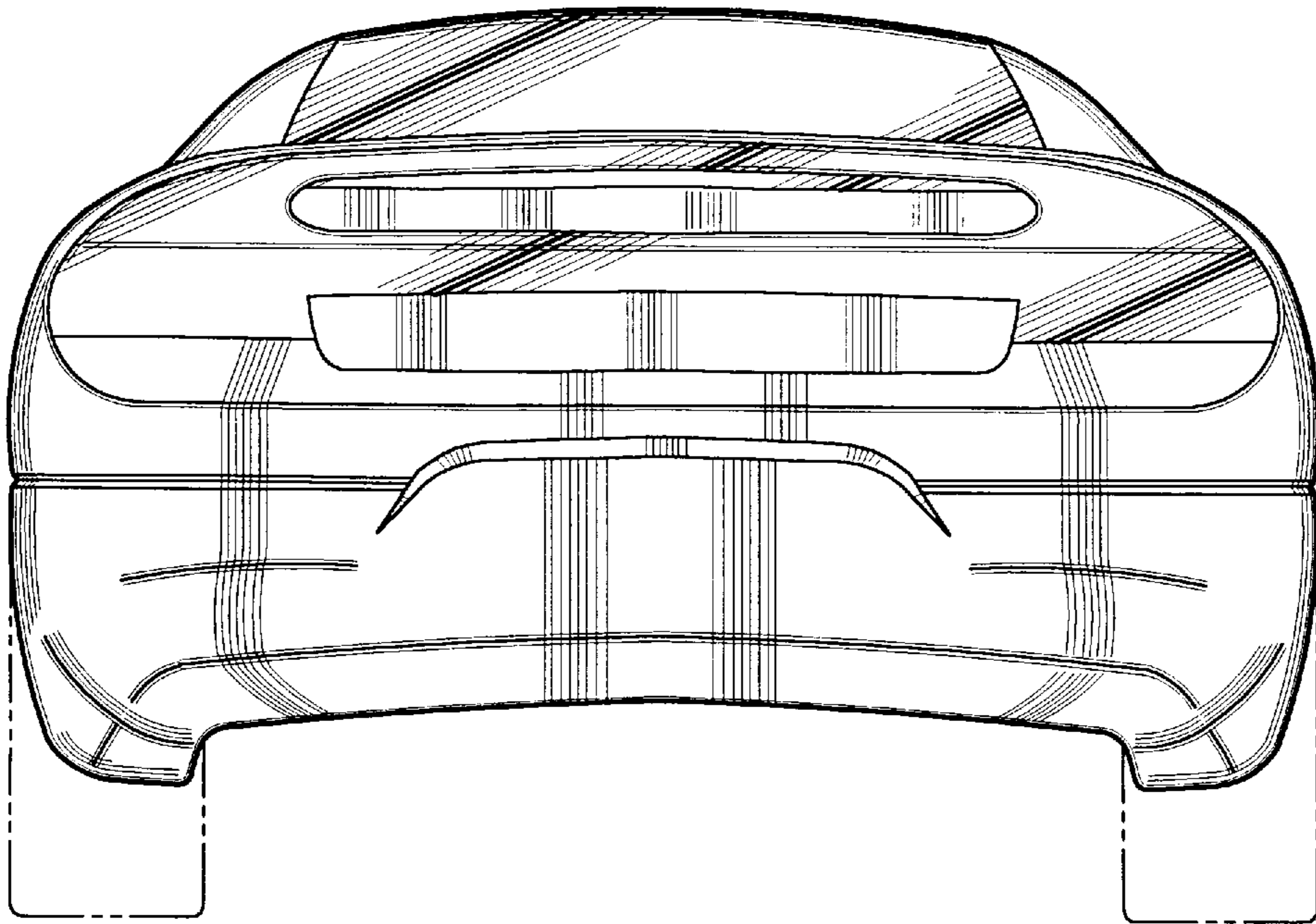

Fig-5