



US00D399462S

# United States Patent [19]

Toffolo et al.

[11] Patent Number: Des. 399,462

[45] Date of Patent: \*\*Oct. 13, 1998

[54] PAIR OF SHOCK ABSORBER ENDS

[75] Inventors: Luigi J. Toffolo; Joseph J. Pinto, both of Wilton, Conn.

[73] Assignee: Frank Roth Company, Inc., Stratford, Conn.

[\*\*] Term: 14 Years

[21] Appl. No.: 70,889

[22] Filed: May 6, 1997

[51] LOC (6) Cl. .... 12-16

[52] U.S. Cl. .... D12/159

[58] Field of Search ..... D12/159; D15/138; 187/344; 248/654, 655; 267/34, 136, 195, 260; 280/668, 673; 410/63

[56] References Cited

U.S. PATENT DOCUMENTS

D. 16,571	3/1886	Kenna	.....	D12/159
D. 194,362	1/1963	Prince	.....	D15/138
D. 202,107	8/1965	Moldt, Jr.	.....	D15/138
D. 230,723	3/1974	Cowan	.....	D12/159
D. 262,959	2/1982	Cowan	.....	D12/159
D. 288,208	2/1987	Hawkins	.....	D15/138
D. 309,616	7/1990	Carter et al.	.....	D15/138
D. 339,595	9/1993	Waskiewicz	.....	D15/138

D. 346,781	5/1994	Homme	.....	D12/159
D. 360,641	7/1995	Asano	.....	D15/138
D. 361,579	8/1995	Asano	.....	D15/138
4,531,618	7/1985	Kobiske et al.	.....	280/668
4,673,192	6/1987	Krehan et al.	.....	280/668
4,762,459	8/1988	Morita et al.	.....	248/654
4,911,466	3/1990	Blair	.....	280/668

OTHER PUBLICATIONS

Chevrolet Shock Absorber AD, Commerical Car Journal, Mar. 1963, p. 38. In Nonpatent Literature.

Primary Examiner—Robert M. Spear  
Attorney, Agent, or Firm—Ware, Fressola, Van der Sluys & Adolphson LLP

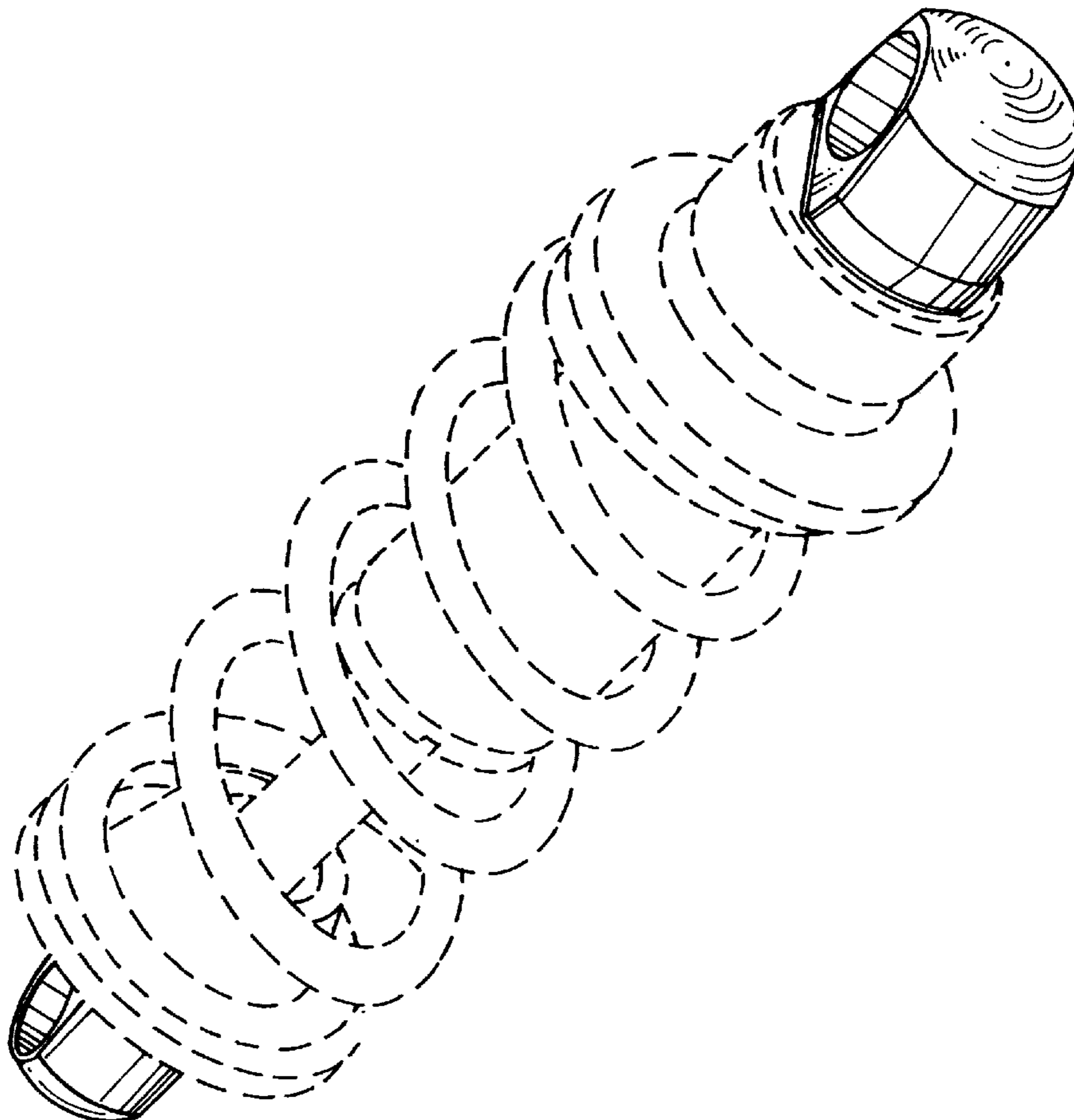
[57] CLAIM

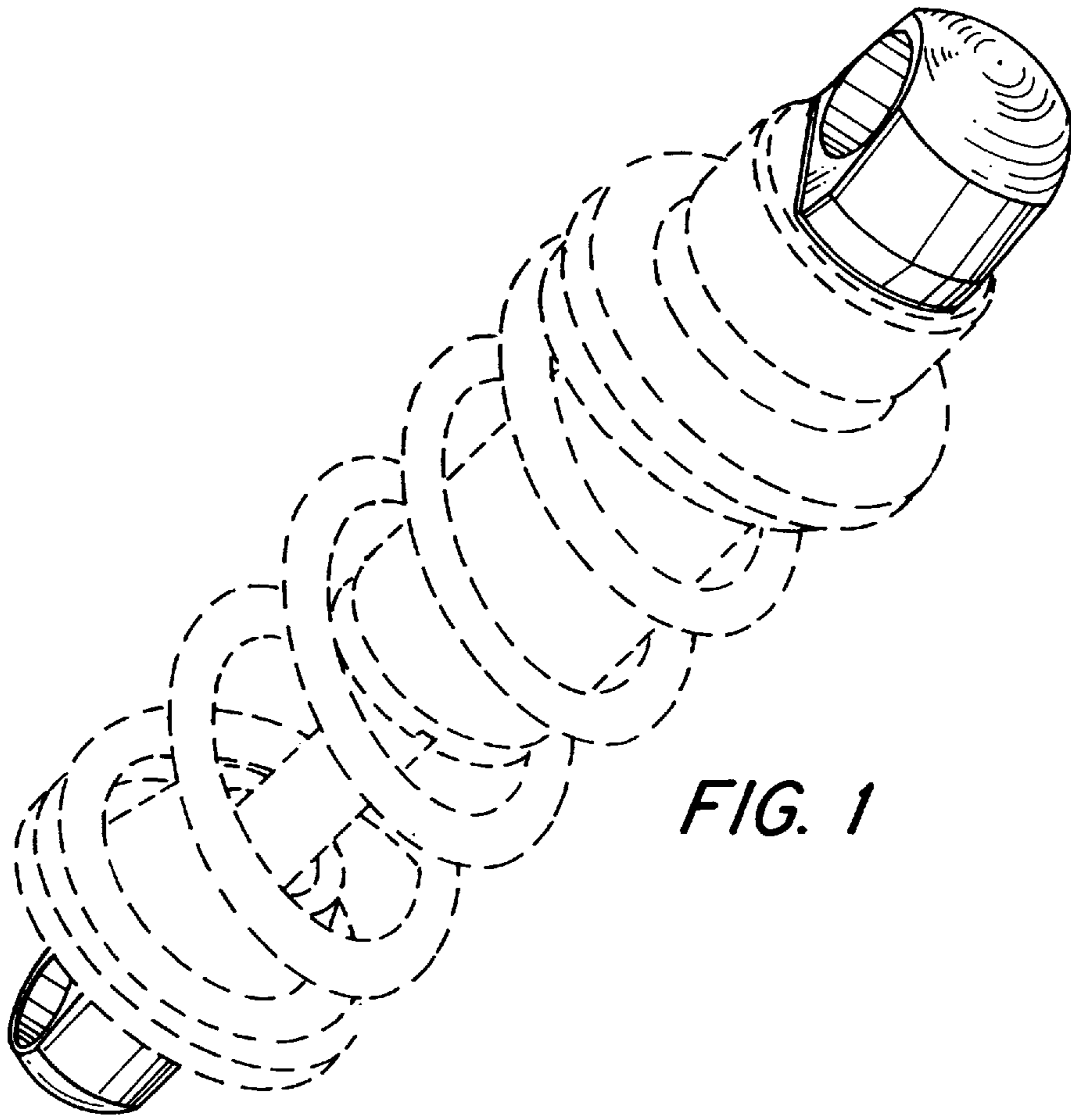
The ornamental design for a pair of shock absorber ends, as shown and described.

DESCRIPTION

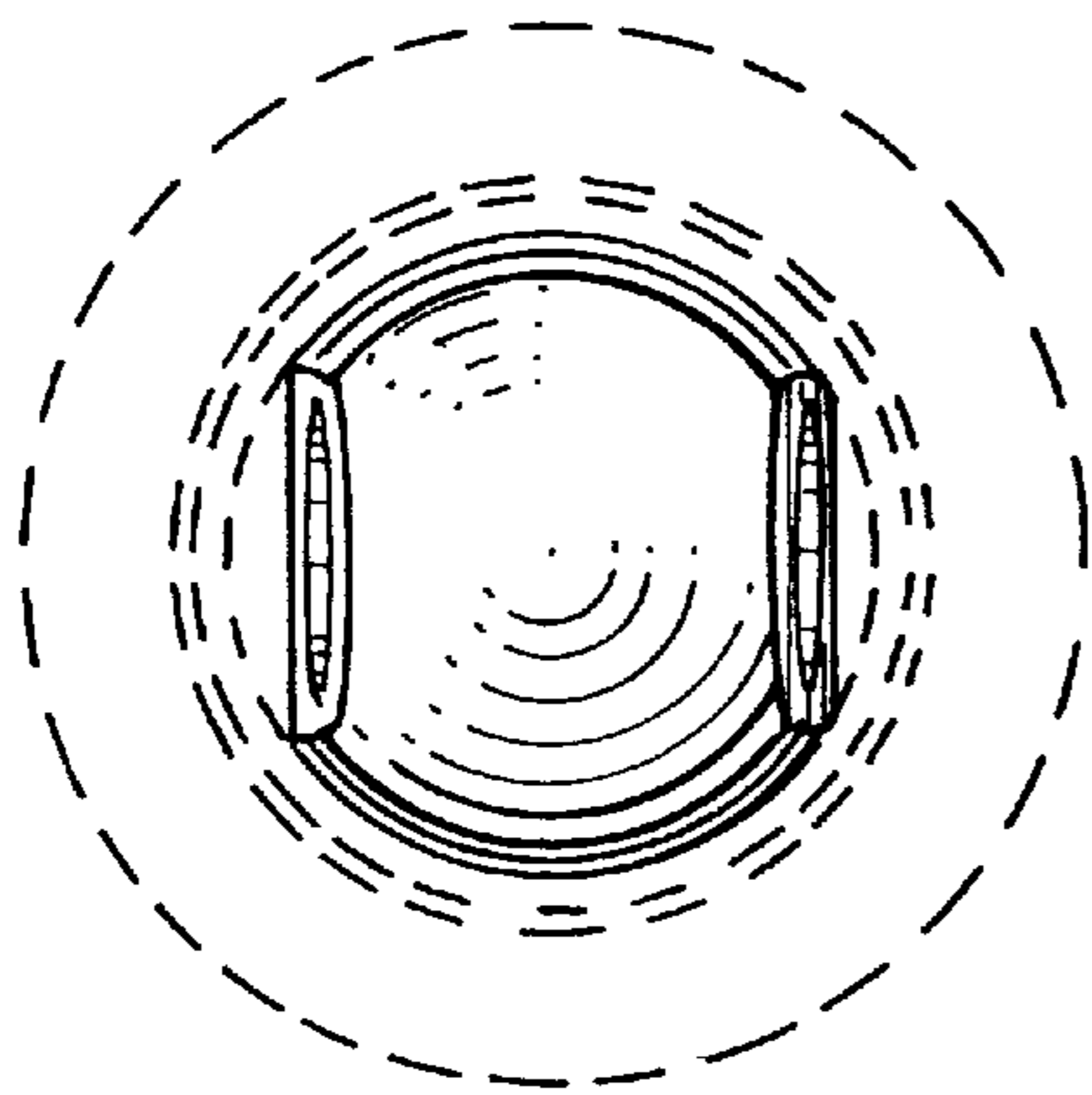
FIG. 1 is a perspective of the invention;  
FIG. 2 is a right end view of the invention;  
FIG. 3 is a left end view of the invention;  
FIG. 4 is a side view of the invention, the opposite side view being identical thereto; and,  
FIG. 5 is a top view of the invention, the bottom view being identical thereto.

1 Claim, 2 Drawing Sheets

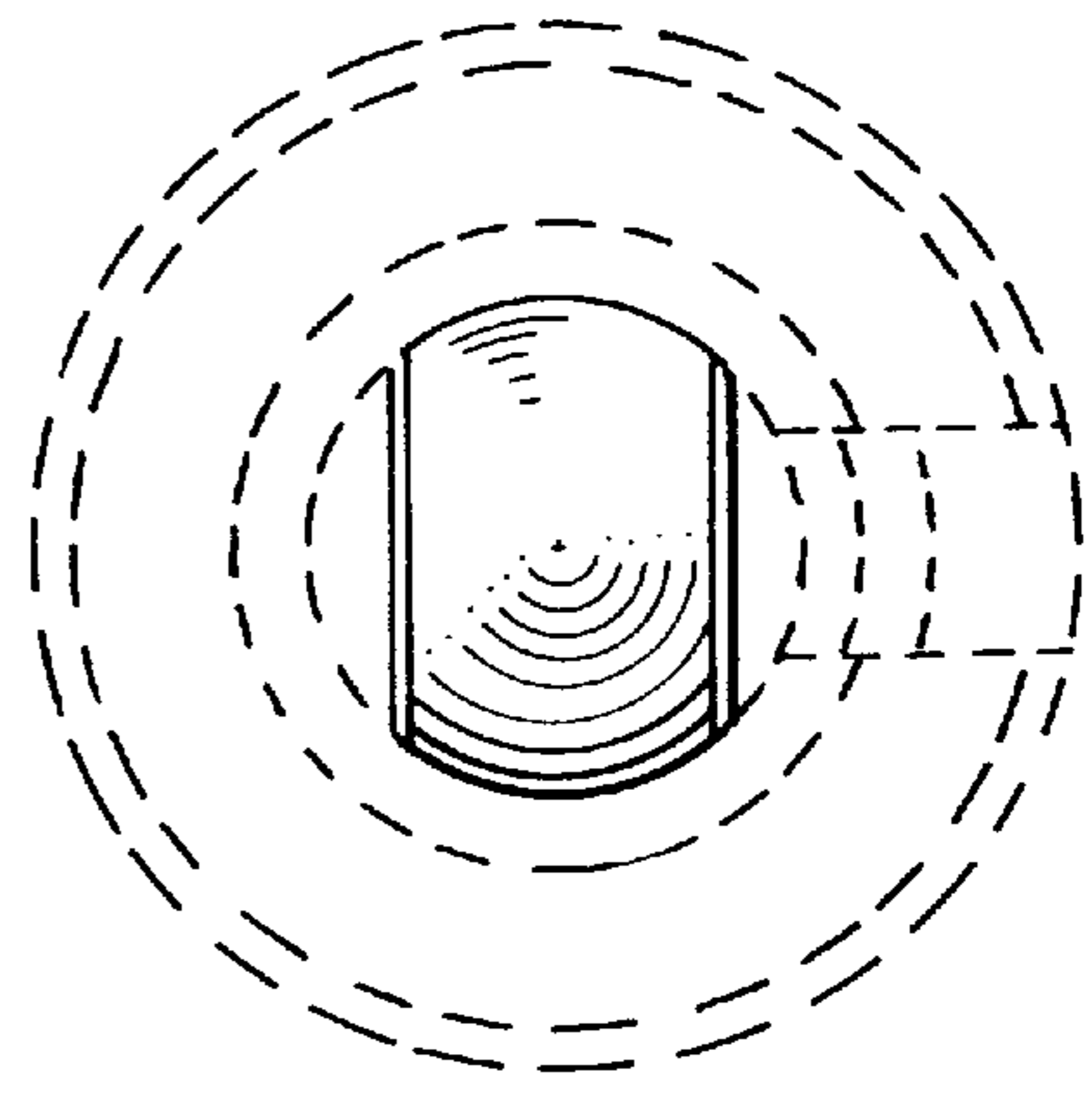




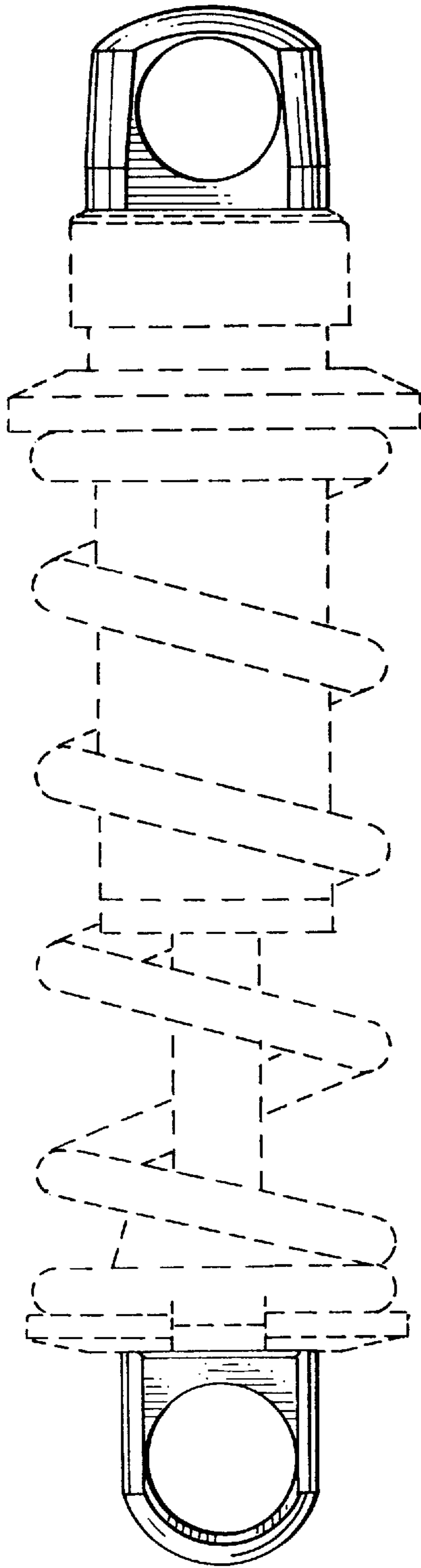
*FIG. 1*



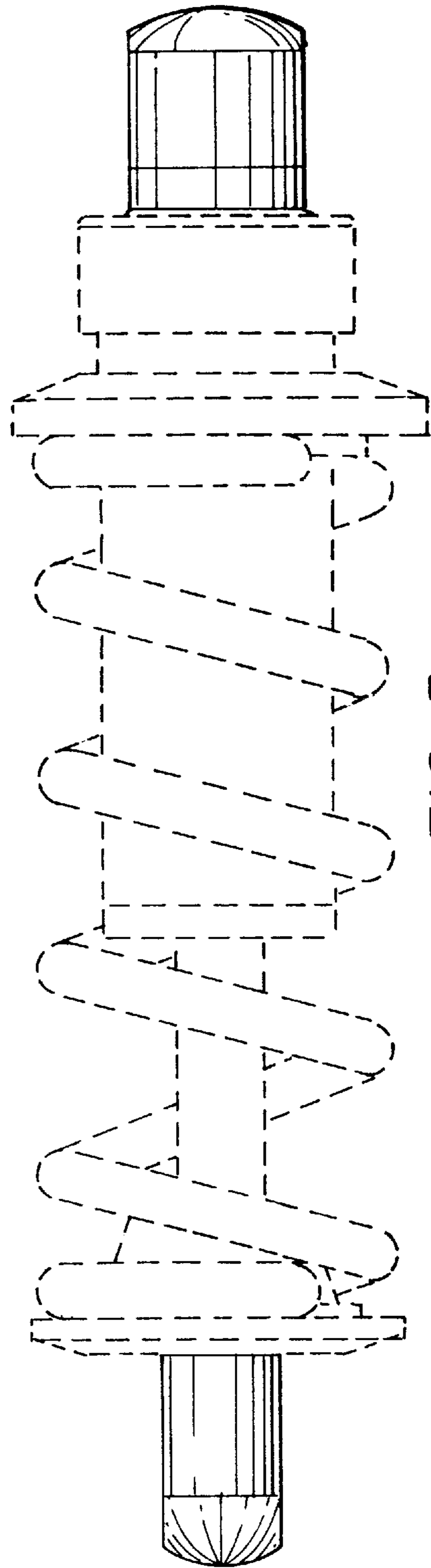
*FIG. 2*



*FIG. 3*



*FIG. 4*



*FIG. 5*